

# CNC自動車床零件

## CNC Automatic lathe parts

# 自動棒材送料機零件

## Automatic bar feeder parts

綜合型錄 Comprehensive catalog **2023**



📍 地址: 51642彰化縣埔鹽鄉彰水路2段202巷5號  
 ☎ 電話(TEL): +886-4-8652727(代表號)  
 📠 傳真(FAX): +886-4-8658278  
 🌐 網站: <http://www.ljrel.com>  
 ✉ E-mail: [chengyisales@gmail.com](mailto:chengyisales@gmail.com)

因為技術上需求或者優化產品，保有產品變動的權利  
 Due to technical needs or product optimization, we reserve the right to change the product

產品將以實際商品為準  
 Products will be based on actual items

版權所有，非經授權，翻印必究  
 All rights reserved, without authorization, reprint must be investigated



**程逸有限公司**  
[www.ljrel.com](http://www.ljrel.com)



A Live tools for CNC lathes & Fixed knife holder  
 B Headstock collets  
 C Guide bushes for lathes  
 D Toggle  
 E Automatic bar feeder parts  
 F CNC lathe parts  
 G Automatic lathe parts  
 H CNC Extension rod  
 I ER Collet/Waterslop collet/Tapping collet/SK collet  
 J Cutting Tool G Series  
 K Cutting Tool J Series  
 L Carbide drill bit/Carbide spot drill/錫鑄鑽/定點鑽

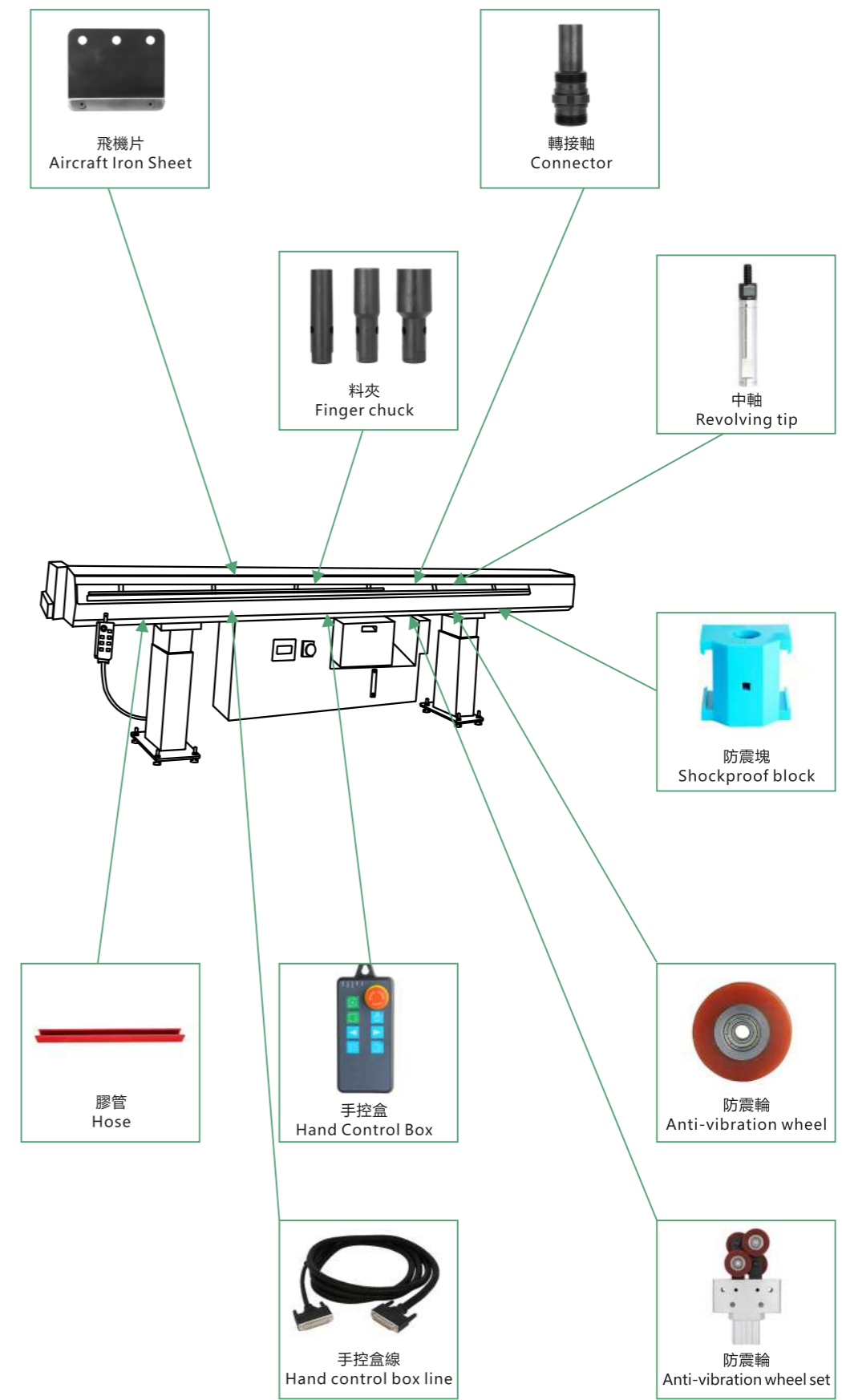
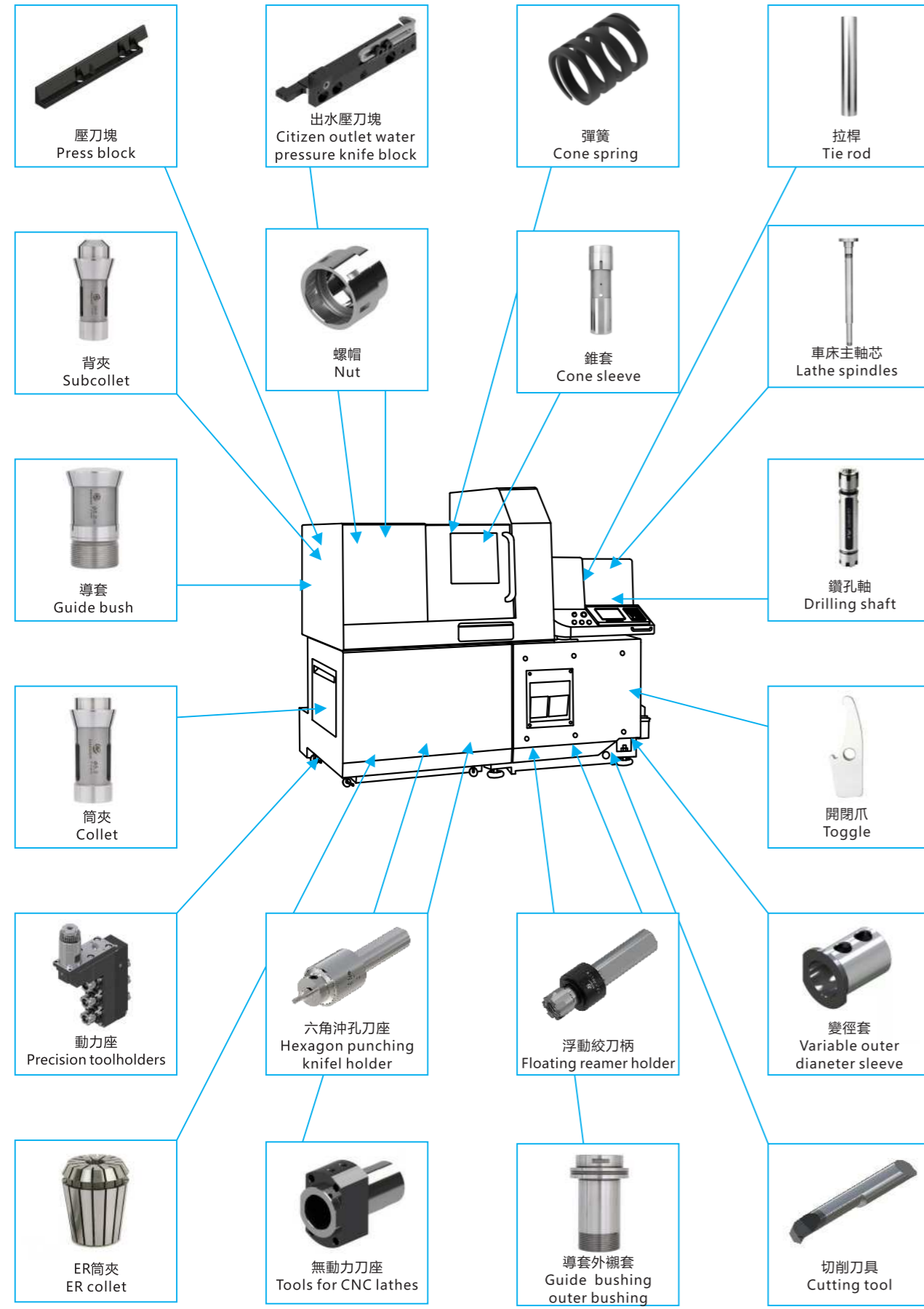

## 微小鎢鋼內徑車刀表示方式 Representation of tiny tungsten steel inner diameter turning tool

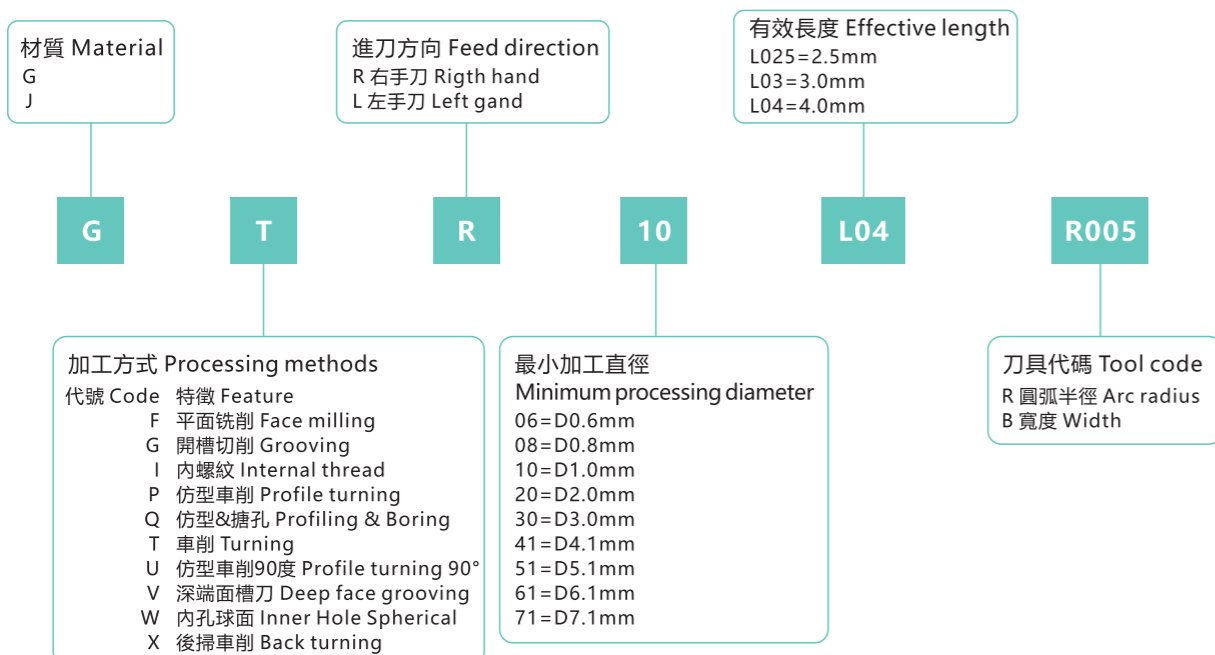

### 快速對刀設計 Quick tool setting design



- 換刀速度快速，減少停機時間，增加產量
- 刀尖高度準確，增加刀具壽命
- 交期快、庫存足、品質優、並且價格極具優勢，C/P值最高
- 可按客戶需求生產，客製化刀具，共用刀桿，降低成本
- 就算是新手也可以在40秒內快速替換，提升生產效率
- 德國進口材料，壽命對比進口廠牌
- Fast tool change speed, reduce downtime and increase output
- The height of the tool tip is accurate, increasing the tool life
- Fast delivery, sufficient inventory, high quality, and extremely competitive price, with the highest C/P value
- Can be produced according to customer needs, customized tools, shared tool holders, reducing costs
- Even a novice can quickly replace within 40 seconds to improve production efficiency
- Materials imported from Germany, the service life is compared with imported brands

## SDK 內孔刀刀柄 Internal hole knife handle

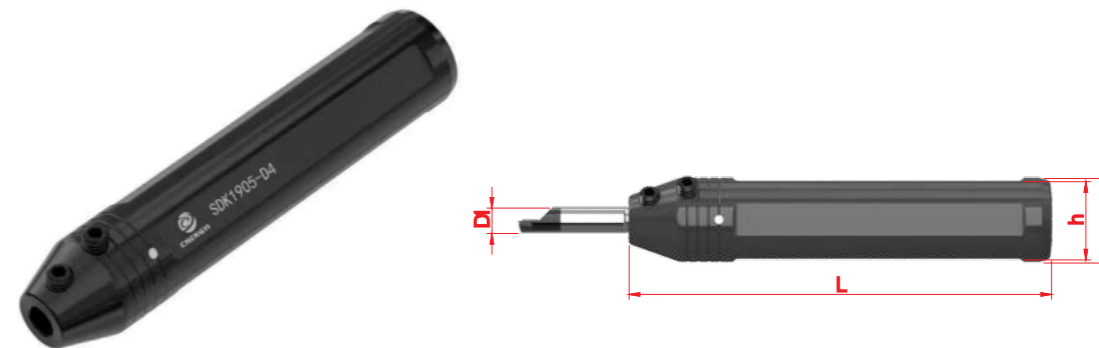

訂購代號 Code	產品型號 Product model	D	D1	L	h
SDK01	SDK1600-D4	16	4	90	14.6
SDK02	SDK1600-D5	16	5	90	14.6
SDK03	SDK1600-D6	16	6	90	14.6
SDK04	SDK1600-D7	16	7	90	14.6
SDK05	SDK1905-D4	19.05	4	90	17.8
SDK06	SDK1905-D5	19.05	5	90	17.8
SDK07	SDK1905-D6	19.05	6	90	17.8
SDK08	SDK1905-D7	19.05	7	90	17.8
SDK09	SDK2000-D4	20	4	90	18.0
SDK10	SDK2000-D5	20	5	90	18.0
SDK11	SDK2000-D6	20	6	90	18.0
SDK12	SDK2000-D7	20	7	90	18.0
SDK13	SDK2200-D4	22	4	130	20.6
SDK14	SDK2200-D5	22	5	130	20.6
SDK15	SDK2200-D6	22	6	130	20.6
SDK16	SDK2200-D7	22	7	130	20.6
SDK17	SDK2500-D4	25	4	90	23.0
SDK18	SDK2500-D5	25	5	90	23.0
SDK19	SDK2500-D6	25	6	90	23.0
SDK20	SDK2500-D7	25	7	90	23.0
SDK21	SDK2540-D4	25.4	4	90	23.0
SDK22	SDK2540-D5	25.4	5	90	23.0
SDK23	SDK2540-D6	25.4	6	90	23.0
SDK24	SDK2540-D7	25.4	7	90	23.0

## GPR 仿型內孔刀 Profiling and boring knife

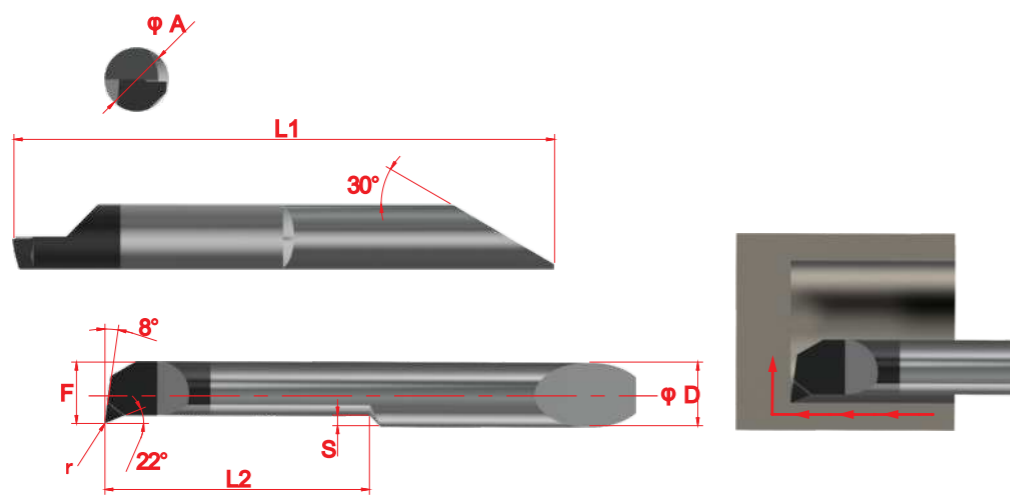

訂購代號 Code	產品型號 Product model	最小加工直徑 Min dia(mm)ØA	ØD	r	L1	L2	F	S
GPR01	GPR06L02R003	0.6	4	0.03	28	2	0.55	0.06
GPR02	GPR08L025R003	0.8	4	0.03	28	2.5	0.75	0.08
GPR03	GPR10L04R005	1.0	4	0.05	29	4	0.9	0.15
GPR03-1	GPR10L04R010	1.0	4	0.10	29	6	0.9	0.15
GPR04	GPR10L06R005	1.0	4	0.05	31	6	0.9	0.15
GPR04-1	GPR10L06R010	1.0	4	0.10	31	6	0.9	0.15
GPR05	GPR12L04R005	1.2	4	0.05	29	4	1.1	0.15
GPR06	GPR12L04R010	1.2	4	0.10	29	4	1.1	0.15
GPR06-1	GPT12L06R005	1.2	4	0.05	29	6	1.1	0.15
GPR06-2	GPR12L06R010	1.2	4	0.10	29	6	1.1	0.15
GPR07	GPR15L05R005	1.5	4	0.05	30	5	1.4	0.20
GPR08	GPR15L05R010	1.5	4	0.10	30	5	1.4	0.20
GPR09	GPR15L08R005	1.5	4	0.05	33	8	1.4	0.20
GPR10	GPR15L08R010	1.5	4	0.10	33	8	1.4	0.20
GPR11	GPR18L05R005	1.8	4	0.05	30	5	1.7	0.20
GPR12	GPR18L05R010	1.8	4	0.10	30	5	1.7	0.20
GPR13	GPR18L09R005	1.8	4	0.05	34	9	1.7	0.20
GPR14	GPR18L09R010	1.8	4	0.10	34	9	1.7	0.20
GPR15	GPR21L06R005	2.1	4	0.05	31	6	1.85	0.25
GPR16	GPR21L06R010	2.1	4	0.10	31	6	1.85	0.25
GPR17	GPR21L10R005	2.1	4	0.05	35	10	1.85	0.25
GPR18	GPR21L10R010	2.1	4	0.10	35	10	1.85	0.25
GPR19	GPR26L08R005	2.6	4	0.05	33	8	2.35	0.30
GPR20	GPR26L08R010	2.6	4	0.10	33	8	2.35	0.30
GPR21	GPR26L08R015	2.6	4	0.15	33	8	2.35	0.30
GPR22	GPR26L12R005	2.6	4	0.05	37	12	2.35	0.30
GPR23	GPR26L12R010	2.6	4	0.10	37	12	2.35	0.30

## GPR 仿型內孔刀 Profiling and boring knife

訂購代號 Code	產品型號 Product model	最小加工直徑 Min dia(mm)ØA	ØD	r	L1	L2	F	S
GPR24	GPR26L12R015	2.6	4	0.15	37	12	2.35	0.30
GPR25	GPR31L10R005	3.1	4	0.05	35	10	2.8	0.50
GPR26	GPR31L10R010	3.1	4	0.10	35	10	2.8	0.50
GPR27	GPR31L10R015	3.1	4	0.15	35	10	2.8	0.50
GPR28	GPR31L15R005	3.1	4	0.05	40	15	2.8	0.50
GPR29	GPR31L15R010	3.1	4	0.10	40	15	2.8	0.50
GPR30	GPR31L15R015	3.1	4	0.15	40	15	2.8	0.50
GPR31	GPR41L12R005	4.1	4	0.05	37	12	3.8	0.60
GPR32	GPR41L12R010	4.1	4	0.10	37	12	3.8	0.60
GPR33	GPR41L12R020	4.1	4	0.20	37	12	3.8	0.60
GPR34	GPR41L16R005	4.1	4	0.05	41	16	3.8	0.60
GPR35	GPR41L16R010	4.1	4	0.10	41	16	3.8	0.60
GPR36	GPR41L16R020	4.1	4	0.20	41	16	3.8	0.60
GPR37	GPR41L20R005	4.1	4	0.05	45	20	3.8	0.60
GPR38	GPR41L20R010	4.1	4	0.10	45	20	3.8	0.60
GPR39	GPR41L20R020	4.1	4	0.20	45	20	3.8	0.60
GPR40	GPR51L15R005	5.1	5	0.05	40	15	4.8	0.80
GPR41	GPR51L15R010	5.1	5	0.10	40	15	4.8	0.80
GPR42	GPR51L15R020	5.1	5	0.20	40	15	4.8	0.80
GPR43	GPR51L20R005	5.1	5	0.05	45	20	4.8	0.80
GPR44	GPR51L20R010	5.1	5	0.10	45	20	4.8	0.80
GPR45	GPR51L20R020	5.1	5	0.20	45	20	4.8	0.80
GPR46	GPR51L25R005	5.1	5	0.05	50	25	4.8	0.80
GPR47	GPR51L25R010	5.1	5	0.10	50	25	4.8	0.80
GPR48	GPR51L25R020	5.1	5	0.20	50	25	4.8	0.80
GPR49	GPR61L15R005	6.1	6	0.05	40	15	5.8	1.00
GPR50	GPR61L15R010	6.1	6	0.10	40	15	5.8	1.00
GPR51	GPR61L15R020	6.1	6	0.20	40	15	5.8	1.00
GPR52	GPR61L20R005	6.1	6	0.05	45	20	5.8	1.00
GPR53	GPR61L20R010	6.1	6	0.10	45	20	5.8	1.00
GPR54	GPR61L20R020	6.1	6	0.20	45	20	5.8	1.00
GPR55	GPR61L25R005	6.1	6	0.05	50	25	5.8	1.00
GPR56	GPR61L25R010	6.1	6	0.10	50	25	5.8	1.00
GPR57	GPR61L25R020	6.1	6	0.20	50	25	5.8	1.00
GPR58	GPR61L30R005	6.1	6	0.05	55	30	5.8	1.00
GPR59	GPR61L30R010	6.1	6	0.10	55	30	5.8	1.00
GPR60	GPR61L30R020	6.1	6	0.20	55	30	5.8	1.00
GPR61	GPR71L25R010	7.1	7	0.10	54	25	6.8	1.20
GPR62	GPR71L25R020	7.1	7	0.20	54	25	6.8	1.20
GPR63	GPR71L35R010	7.1	7	0.10	64	35	6.8	1.20
GPR64	GPR71L35R020	7.1	7	0.20	64	35	6.8	1.20

## GTR 內孔刀 Internal boring knife

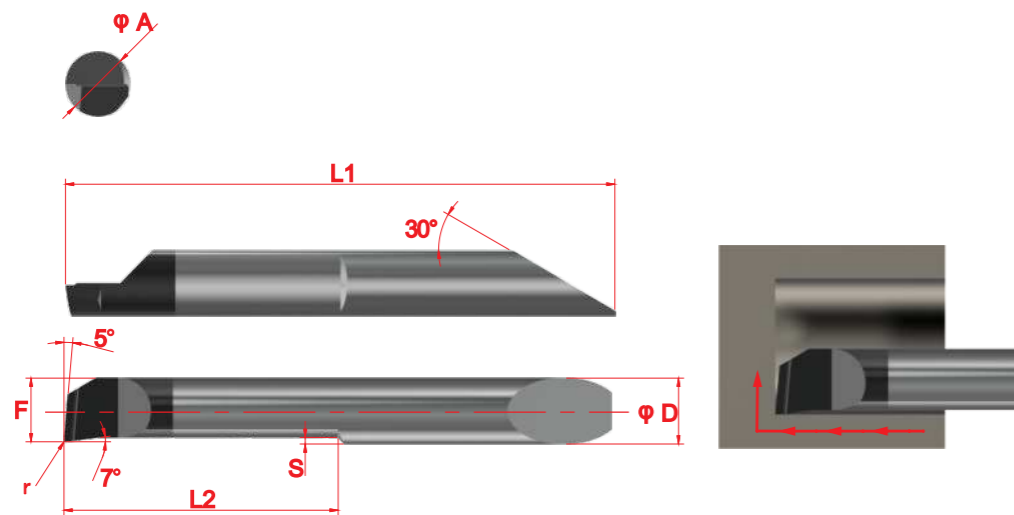

訂購代號 Code	產品型號 Product model	最小加工直徑 Min dia(mm)ØA	ØD	r	L1	L2	F	S
GTR01	GTR21L06R005	2.1	4	0.05	31	6	1.85	0.20
GTR02	GTR21L06R010	2.1	4	0.10	31	6	1.85	0.20
GTR03	GTR21L10R005	2.1	4	0.05	35	10	1.85	0.20
GTR04	GTR21L10R010	2.1	4	0.10	35	10	1.85	0.20
GTR05	GTR26L08R005	2.6	4	0.05	33	8	2.35	0.25
GTR06	GTR26L08R010	2.6	4	0.10	33	8	2.35	0.25
GTR07	GTR26L08R015	2.6	4	0.15	33	8	2.35	0.25
GTR08	GTR26L12R005	2.6	4	0.05	37	12	2.35	0.25
GTR09	GTR26L12R010	2.6	4	0.10	37	12	2.35	0.25
GTR10	GTR26L12R015	2.6	4	0.15	37	12	2.35	0.25
GTR11	GTR31L10R005	3.1	4	0.05	35	10	2.8	0.30
GTR12	GTR31L10R010	3.1	4	0.10	35	10	2.8	0.30
GTR13	GTR31L10R015	3.1	4	0.15	35	10	2.8	0.30
GTR14	GTR31L15R005	3.1	4	0.05	40	15	2.8	0.30
GTR15	GTR31L15R010	3.1	4	0.10	40	15	2.8	0.30
GTR16	GTR31L15R015	3.1	4	0.15	40	15	2.8	0.30
GTR17	GTR41L12R005	4.1	4	0.05	37	12	3.8	0.40
GTR18	GTR41L12R010	4.1	4	0.10	37	12	3.8	0.40
GTR19	GTR41L12R020	4.1	4	0.20	37	12	3.8	0.40
GTR20	GTR41L16R005	4.1	4	0.05	41	16	3.8	0.40
GTR21	GTR41L16R010	4.1	4	0.10	41	16	3.8	0.40
GTR22	GTR41L16R020	4.1	4	0.20	41	16	3.8	0.40
GTR23	GTR41L20R005	4.1	4	0.05	45	20	3.8	0.40
GTR24	GTR41L20R010	4.1	4	0.10	45	20	3.8	0.40
GTR25	GTR41L20R020	4.1	4	0.20	45	20	3.8	0.40
GTR26	GTR51L15R010	5.1	5	0.10	40	15	4.8	0.50
GTR27	GTR51L15R020	5.1	5	0.20	40	15	4.8	0.50

## GTR 內孔刀 Internal boring knife

訂購代號 Code	產品型號 Product model	最小加工直徑 Min dia(mm)ØA	ØD	r	L1	L2	F	S
GTR28	GTR51L20R010	5.1	5	0.10	45	20	4.8	0.50
GTR29	GTR51L20R020	5.1	5	0.20	45	20	4.8	0.50
GTR30	GTR51L25R010	5.1	5	0.10	50	25	4.8	0.50
GTR31	GTR51L25R020	5.1	5	0.20	50	25	4.8	0.50
GTR32	GTR61L15R010	6.1	6	0.10	40	15	5.8	0.60
GTR33	GTR61L15R020	6.1	6	0.20	40	15	5.8	0.60
GTR34	GTR61L20R010	6.1	6	0.10	45	20	5.8	0.60
GTR35	GTR61L20R020	6.1	6	0.20	45	20	5.8	0.60
GTR36	GTR61L25R010	6.1	6	0.10	50	25	5.8	0.60
GTR37	GTR61L25R020	6.1	6	0.20	50	25	5.8	0.60
GTR38	GTR61L30R010	6.1	6	0.10	55	30	5.8	0.60
GTR39	GTR61L30R020	6.1	6	0.20	55	30	5.8	0.60
GTR40	GTR71L25R010	7.1	7	0.10	54	25	6.8	0.70
GTR41	GTR71L25R020	7.1	7	0.20	54	25	6.8	0.70
GTR42	GTR71L35R010	7.1	7	0.10	64	35	6.8	0.70
GTR43	GTR71L35R020	7.1	7	0.20	64	35	6.8	0.70

## GUR 仿型平底內孔刀 Profiling flat bottom inner hole knife

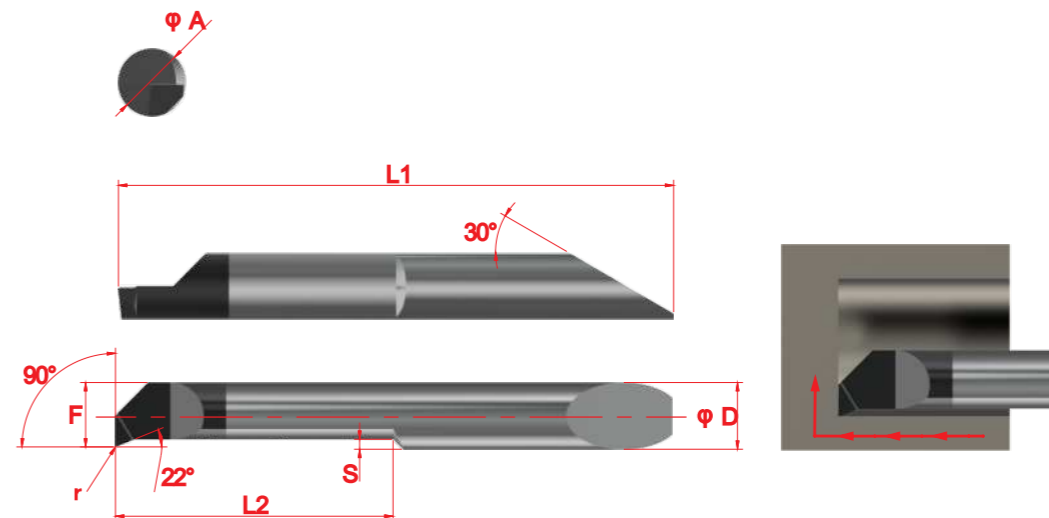

訂購代號 Code	產品型號 Product model	最小加工直徑 Min dia(mm)ØA	ØD	r	L1	L2	F	S
GUR01	GUR31L10R010	3.1	4	0.10	35	10	2.8	0.40
GUR02	GUR41L12R010	4.1	4	0.10	37	12	3.8	0.50
GUR03	GUR51L15R015	5.1	5	0.15	40	15	4.8	0.70
GUR04	GUR61L22R015	6.1	6	0.15	45	22	5.8	0.90

A 無動力刀座  
Live tools for CNC lathes  
& Fixed knife holder

B 車床筒夾  
Headstock collets

C 車床導套  
Guide bushes  
for lathes

D 開閉爪  
Toggle

E 送料機零件  
Automatic bar  
feeder parts

F CNC車床零件  
CNC lathe parts

G 車床零件  
各種機自動  
Automatic lathe  
parts

H CNC車床鑽孔軸  
CNC Extension rod

I 攻牙筒夾/SK筒夾  
ER筒夾/止水筒夾  
ER Collet/Waterstop collet/  
Tapping collet/SK collet

J 切削刀具G系列  
Cutting Tool G Series

K 切削刀具J系列  
Cutting Tool J Series

L 鎢鋼鑽頭定點鑽  
Carbide spot drill

A 無動力刀座  
Live tools for CNC lathes  
& Fixed knife holder

B 車床筒夾  
Headstock collets

C 車床導套  
Guide bushes  
for lathes

D 開閉爪  
Toggle

E 送料機零件  
Automatic bar  
feeder parts

F CNC車床零件  
CNC lathe parts

G 車床零件  
各種機自動  
Automatic lathe  
parts

H CNC車床鑽孔軸  
CNC Extension rod

I 攻牙筒夾/SK筒夾  
ER筒夾/止水筒夾  
ER Collet/Waterstop collet/  
Tapping collet/SK collet

J 切削刀具G系列  
Cutting Tool G Series

K 切削刀具J系列  
Cutting Tool J Series

L 鎢鋼鑽頭定點鑽  
Carbide spot drill

## GXR 反向內孔刀 Reverse internal bore knife

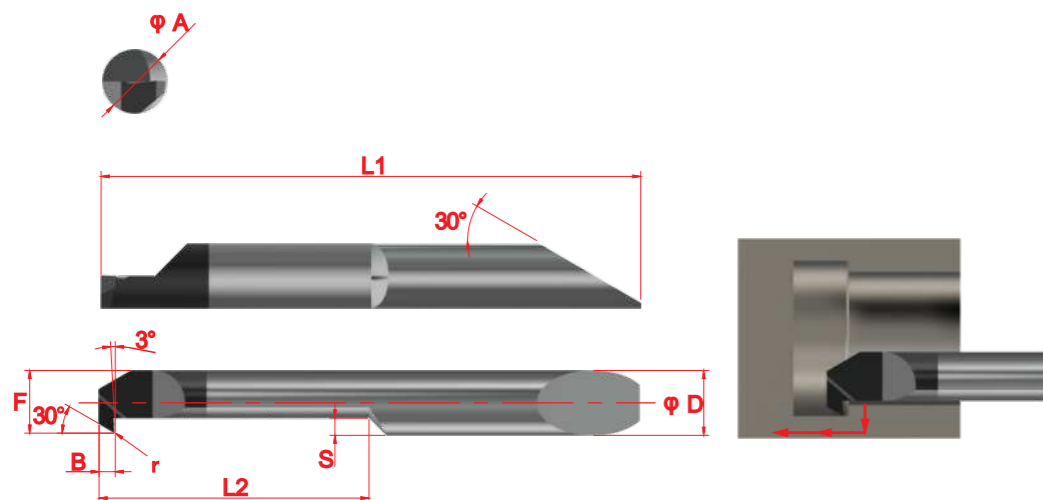

訂購代號 Code	產品型號 Product model	最小加工直徑 Min dia(mm)ØA	ØD	r	L1	L2	F	S	B
GXR01	GXR41L16R010	4.1	4	0.10	41	16	3.8	1.00	1.50
GXR02	GXR51L20R010	5.1	5	0.10	45	20	4.8	1.30	1.50
GXR03	GXR61L25R010	6.1	6	0.10	50	25	5.8	1.60	1.50

## GVR 深端面槽刀 Deep face grooving knife

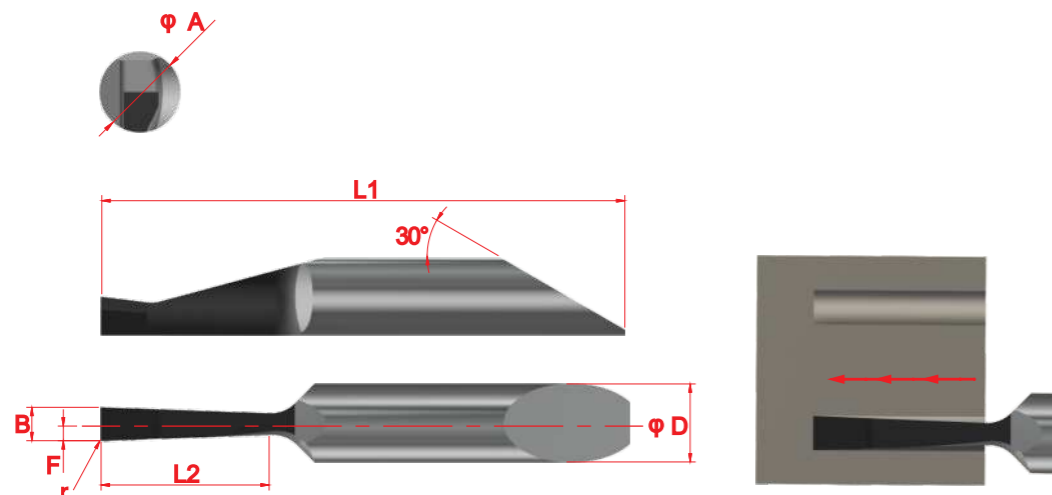

訂購代號 Code	產品型號 Product model	最小加工直徑 Min dia(mm)ØA	ØD	r	L1	L2	F	B
GVR01	GVR12L15B200	12.0	7	0.20	47	15	1.1	2.00
GVR02	GVR12L15B250	12.0	7	0.20	47	15	1.4	2.50
GVR03	GVR12L15B300	12.0	7	0.20	47	15	1.6	3.00

## GFR 端面槽刀 Face grooving knife

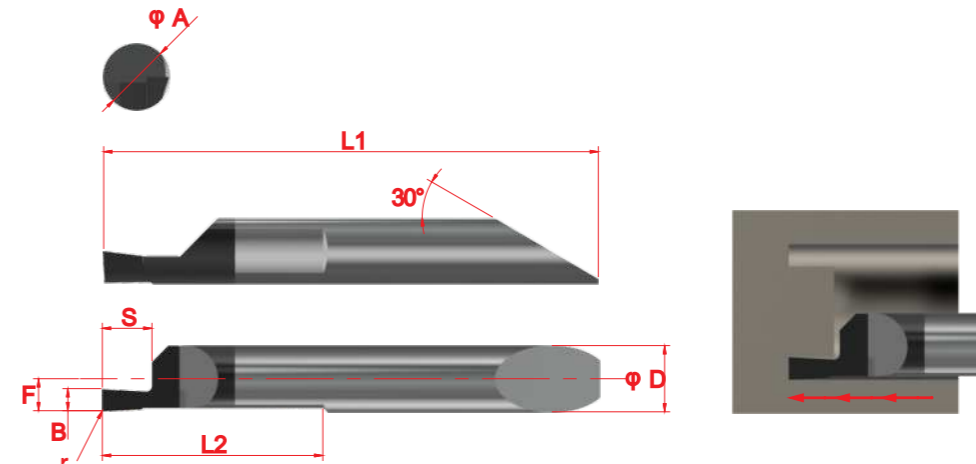

訂購代號 Code	產品型號 Product model	最小加工直徑 Min dia(mm)ØA	ØD	r	L1	L2	F	S	B
GFR01	GFR50L12B050	5.0	4	0.05	37	12	1.9	1.00	0.50
GFR02	GFR50L12B100	5.0	4	0.05	37	12	1.9	1.50	1.00
GFR03	GFR50L12B150	5.0	4	0.05	37	12	1.9	2.00	1.50
GFR04	GFR60L15B100	6.0	5	0.10	40	15	2.4	1.50	1.00
GFR05	GFR60L15B150	6.0	5	0.10	40	15	2.4	2.50	1.50
GFR06	GFR60L15B200	6.0	5	0.10	40	15	2.4	3.00	2.00
GFR07	GFR80L20B100	8.0	6	0.10	45	20	2.9	2.00	1.00
GFR08	GFR80L20B150	8.0	6	0.10	45	20	2.9	2.50	1.50
GFR09	GFR80L20B200	8.0	6	0.10	45	20	2.9	3.00	2.00
GFR10	GFR80L20B300	8.0	6	0.10	45	20	2.9	4.50	3.00

## GFL 端面槽刀 Face grooving knife

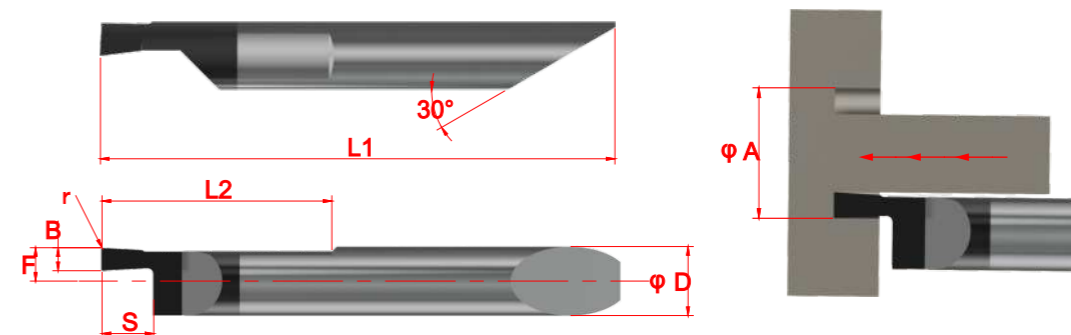

訂購代號 Code	產品型號 Product model	最小加工直徑 Min dia(mm)ØA	ØD	r	L1	L2	F	S	B
GFL01	GFL62L20B080	6.2	6	0.05	45	20	2.9	1.80	0.80
GFL02	GFR62L20B100	6.2	6	0.05	45	20	2.9	2.00	1.00
GFL03	GFR62L20B150	6.2	6	0.10	45	20	2.9	3.00	1.50
GFL04	GFR62L20B200	6.2	6	0.10	45	20	2.9	4.00	2.00
GFL05	GFR62L20B250	6.2	6	0.10	45	20	2.9	5.00	2.50

A 無動力刀座  
Live tools for CNC lathes  
& Fixed knife holder

B 車床筒夾  
Headstock collets

C 車床導套  
Guide bushes  
for lathes

D 開閉爪  
Toggle

E 送料機零件  
Automatic bar  
feeder parts

F CNC車床零件  
CNC lathe parts

G 車床零件  
Automatic lathe  
parts

H CNC車床鑽孔軸  
CNC Extension rod

I 攻牙筒夾/SK筒夾  
ER筒夾/止水筒夾  
ER Collet/Waterstop collet/  
Tapping collet/SK collet

J 切削刀具G系列  
Cutting Tool G Series

K 切削刀具J系列  
Cutting Tool J Series

L 鎢鋼鑽頭定點鑽  
Carbide drill bit/  
Carbide spot drill

A 無動力刀座  
Live tools for CNC lathes  
& Fixed knife holder

B 車床筒夾  
Headstock collets

C 車床導套  
Guide bushes  
for lathes

D 開閉爪  
Toggle

E 送料機零件  
Automatic bar  
feeder parts

F CNC車床零件  
CNC lathe parts

G 車床零件  
Automatic lathe  
parts

H CNC車床鑽孔軸  
CNC Extension rod

I 攻牙筒夾/SK筒夾  
ER筒夾/止水筒夾  
ER Collet/Waterstop collet/  
Tapping collet/SK collet

J 切削刀具G系列  
Cutting Tool G Series

K 切削刀具J系列  
Cutting Tool J Series

L 鎢鋼鑽頭定點鑽  
Carbide drill bit/  
Carbide spot drill

## GWR 內孔球面刀 Inner hole spherical knife

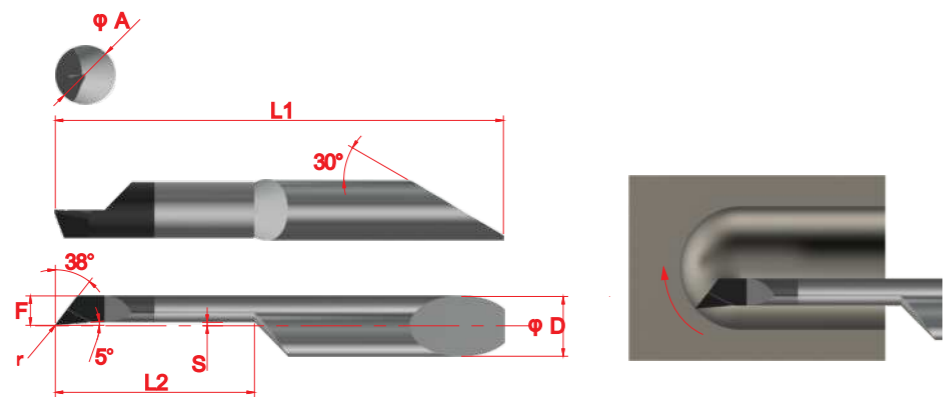

訂購代號 Code	產品型號 Product model	最小加工直徑 Min dia(mm)ØA	ØD	r	L1	L2	F	S
GWR01	GWR35L08R010	3.5	4	0.10	33	8	1.55	0.15
GWR02	GWR45L10R010	4.5	4	0.10	35	10	1.95	0.25
GWR03	GWR55L12R010	5.5	5	0.10	38	12	2.45	0.30
GWR04	GWR65L15R010	6.5	6	0.10	40	15	2.95	0.35

## GIL 60°內孔牙刀(左手刀) 60° Internal threading knife (left hand knife)

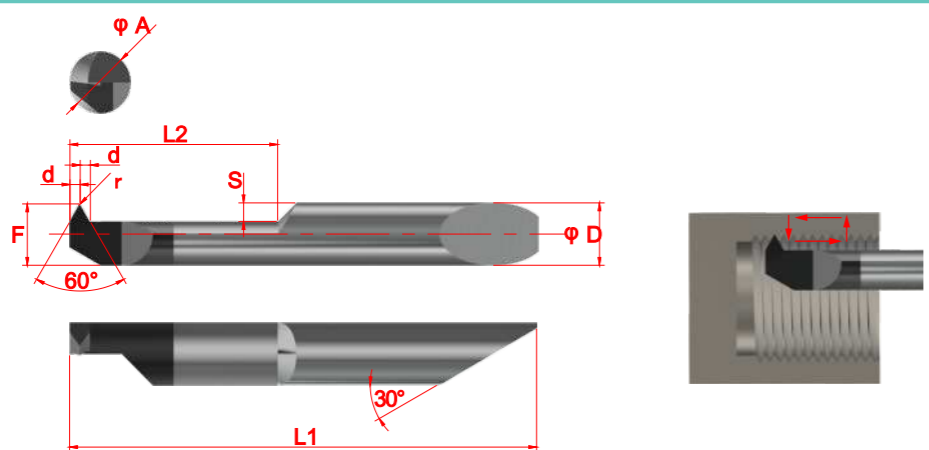

訂購代號 Code	產品型號 Product model	最小加工直徑 Min dia(mm)ØA	ØD	w	h	L1	L2	F	S	θ	螺距範圍(mm) Pitch range
GIL01	GIL15L04A060X	1.5	4	0.05	0.720	29	4	1.4	0.4	60°	P0.5~P0.8
GIL02	GIL20L06A060	2.0	4	0.10	0.750	31	6	1.9	0.5	60°	P0.8~P1.0
GIL03	GIL25L08A060X	2.5	4	0.06	0.895	33	8	2.4	0.6	60°	P0.5~P1.0
GIL04	GIL30L10A060	3.0	4	0.12	0.925	35	10	2.9	1.0	60°	P1.0~P1.5
GIL05	GIL40L12A060X	4.0	4	0.08	1.070	37	12	3.9	1.2	60°	P0.5~P1.0
GIL06	GIL40L12A060	4.0	4	0.16	1.10	37	12	3.9	1.2	60°	P1.0~P1.75
GIL07	GIL40L12A060X	4.0	4	0.05	0.720	37	12	3.9	1.2	60°	P0.5~P0.8
GIL08	GIL40L12A060	4.0	4	0.10	0.750	37	12	3.9	1.2	60°	P0.8~P1.0
GIL09	GIL50L15A060X	5.0	5	0.06	0.895	40	15	4.9	1.5	60°	P0.5~P1.0
GIL10	GIL50L15A060	5.0	5	0.12	0.925	40	15	4.9	1.5	60°	P1.0~P1.5
GIL11	GIL60L20A060X	6.0	6	0.08	1.070	45	20	5.9	1.8	60°	P0.5~P1.0
GIL12	GIL60L20A060	6.0	6	0.16	1.10	45	20	5.9	1.8	60°	P1.0~P1.75

※ X表示可以加工更小的螺距，從0.4開始。 X means that smaller pitches can be processed, starting from 0.4

## GQR 仿型內孔刀 Profiling inner hole knife

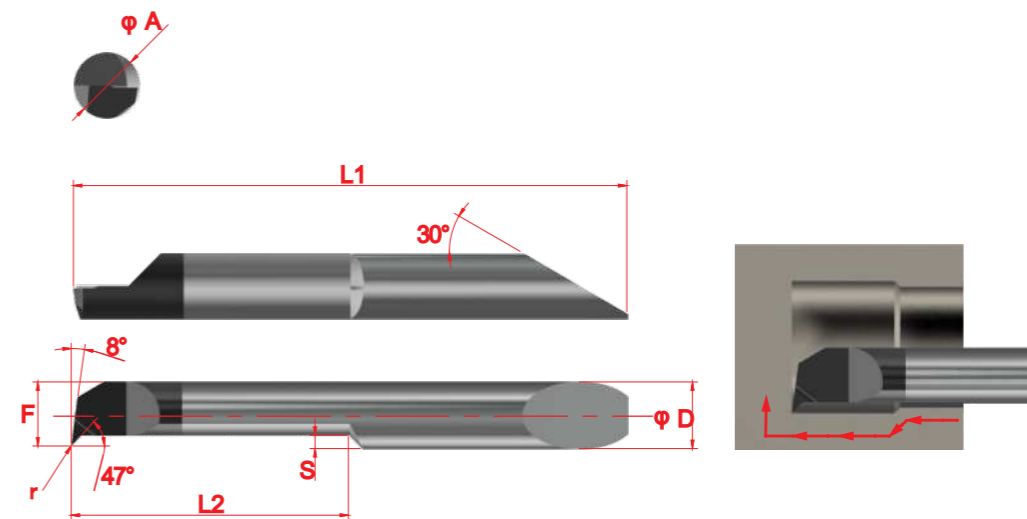

訂購代號 Code	產品型號 Product model	最小加工直徑 Min dia(mm)ØA	ØD	r	L1	L2	F	S
GQR01	GQR31L10R005	3.1	4	0.05	35	10	2.8	0.60
GQR02	GQR31L10R010	3.1	4	0.10	35	10	2.8	0.60
GQR03	GQR31L15R005	3.1	4	0.05	37	15	2.8	0.60
GQR04	GQR31L15R010	3.1	4	0.10	37	15	2.8	0.60
GQR05	GQR41L12R005	4.1	4	0.05	37	12	3.8	0.80
GQR06	GQR41L12R010	4.1	4	0.10	37	12	3.8	0.80
GQR07	GQR41L16R005	4.1	4	0.05	41	16	3.8	0.80
GQR08	GQR41L16R010	4.1	4	0.10	41	16	3.8	0.80
GQR09	GQR41L20R005	4.1	4	0.05	45	20	3.8	0.80
GQR10	GQR41L20R010	4.1	4	0.10	45	20	3.8	0.80
GQR11	GQR51L20R005	5.1	5	0.05	45	20	4.8	1.00
GQR12	GQR51L20R015	5.1	5	0.15	45	20	4.8	1.00
GQR13	GQR51L25R005	5.1	5	0.05	50	25	4.8	1.00
GQR14	GQR51L25R015	5.1	5	0.15	50	25	4.8	1.00
GQR15	GQR61L20R005	6.1	6	0.05	45	20	5.8	1.20
GQR16	GQR61L20R015	6.1	6	0.15	45	20	5.8	1.20
GQR17	GQR61L25R005	6.1	6	0.05	50	25	5.8	1.20
GQR18	GQR61L25R015	6.1	6	0.15	50	25	5.8	1.20
GQR19	GQR61L30R005	6.1	6	0.05	55	30	5.8	1.20
GQR20	GQR61L30R015	6.1	6	0.15	55	30	5.8	1.20

## GIR 60°內孔牙刀 60° Internal threading knife

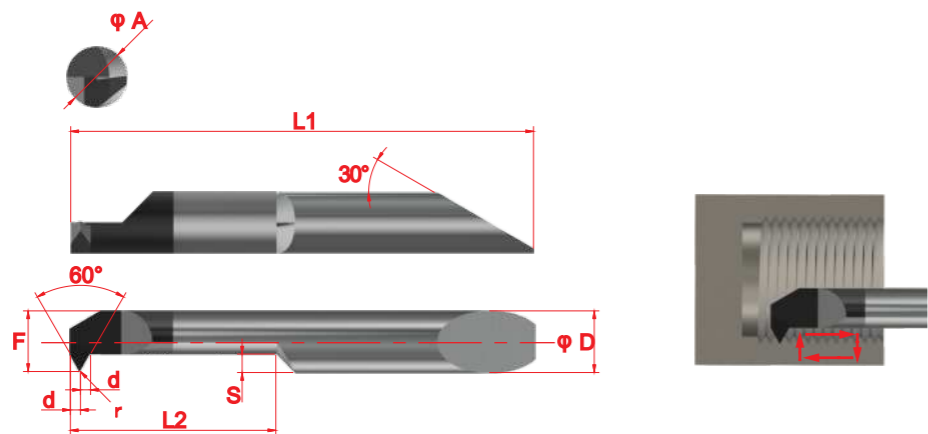

訂購代號 Code	產品型號 Product model	最小加工直徑 Min dia(mm)ØA	ØD	w	r	h	L1	L2	F	S	θ	螺距範圍(mm) Pitch range
GIR01	GIR15L04A060	1.5	4	0.03	/	0.250	29	4	1.4	0.4	60°	P0.25~P0.4
GIR02	GIR20L06A060	2.0	4	0.04	/	0.305	31	6	1.9	0.5	60°	P0.3~P0.5
GIR03	GIR25L08A060	2.5	4	0.06	/	0.375	33	8	2.4	0.6	60°	P0.4~P0.6
GIR04	GIR30L10A060	3.0	4	/	0.05	0.605	35	10	2.9	1.0	60°	P0.5~P0.8
GIR05	GIR40L12A060X	4.0	4	/	0.05	0.720	37	12	3.9	1.2	60°	P0.5~P1.0
GIR06	GIR40L12A060	4.0	4	/	0.10	0.750	37	12	3.9	1.2	60°	P1.0~P1.5
GIR07	GIR50L15A060X	5.0	5	/	0.05	0.895	40	15	4.9	1.5	60°	P0.5~P1.0
GIR08	GIR50L15A060	5.0	5	/	0.10	0.925	40	15	4.9	1.5	60°	P1.0~P1.5
GIR09	GIR60L20A060X	6.0	6	/	0.05	1.070	45	20	5.9	1.8	60°	P0.5~P1.0
GIR10	GIR60L20A060	6.0	6	/	0.10	1.095	45	20	5.9	1.8	60°	P1.0~P1.75

※ X表示可以加工更小的螺距，從0.4開始。X means that smaller pitches can be processed, starting from 0.4

## GIR 55°內孔牙刀 55° Internal threading knife

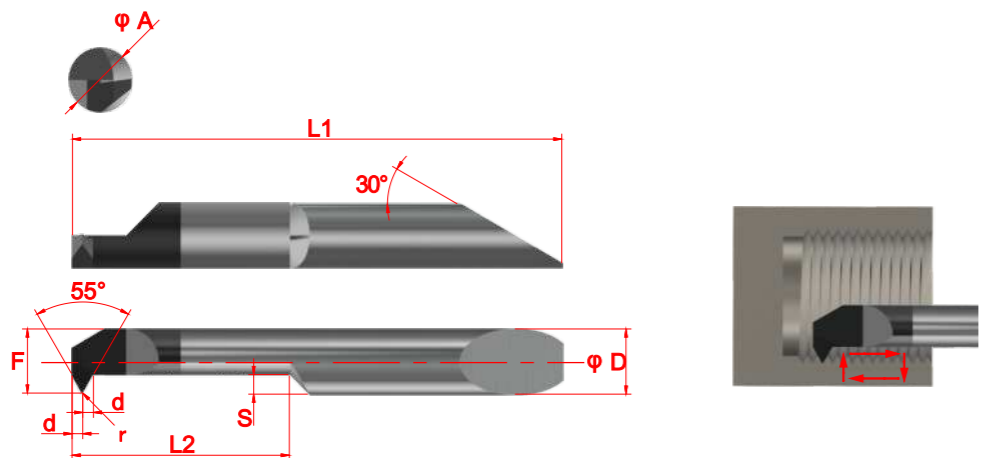

訂購代號 Code	產品型號 Product model	最小加工直徑 Min dia(mm)ØA	ØD	r	L1	L2	F	S	θ	可加工每英寸牙數範圍 Pitch range
GIR11	GIR31L10A055	3.1	4	0.05	35	10	2.9	1.00	55°	48-24
GIR12	GIR41L12A055	4.1	4	0.05	37	12	3.9	1.20	55°	48-24
GIR13	GIR51L15A055	5.1	5	0.08	40	15	4.9	1.60	55°	48-16
GIR14	GIR61L20A055	6.1	6	0.08	45	20	5.9	1.90	55°	48-12
GIR15	GIR71L25A055	7.1	7	0.15	54	25	7.9	2.50	55°	26-11



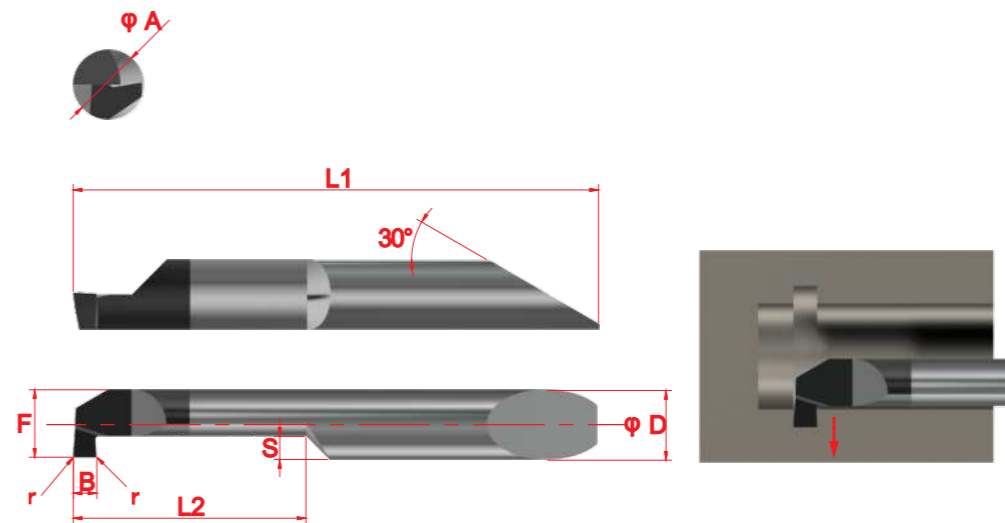



## GGR 內孔切槽刀 Inner hole grooving knife



訂購代號 Code	產品型號 Product model	最小加工直徑 Min dia(mm)ØA	ØD	r	L1	L2	F	S	B
GGR01	GGR26L05B050	2.6	4	0.05	30	5	2.35	0.65	0.50
GGR02	GGR26L05B075	2.6	4	0.05	30	5	2.35	0.65	0.75
GGR03	GGR31L05B050	3.1	4	0.05	30	5	2.8	0.80	0.50
GGR04	GGR31L05B075	3.1	4	0.05	30	5	2.8	0.80	0.75
GGR05	GGR31L05B100	3.1	4	0.05	30	5	2.8	0.80	1.00
GGR06	GGR31L10B050	3.1	4	0.05	35	10	2.8	0.80	0.50
GGR07	GGR31L10B075	3.1	4	0.05	35	10	2.8	0.80	0.75
GGR08	GGR31L10B100	3.1	4	0.05	35	10	2.8	0.80	1.00
GGR09	GGR41L06B050	4.1	4	0.05	31	6	3.8	1.00	0.50
GGR10	GGR41L06B075	4.1	4	0.05	31	6	3.8	1.00	0.75
GGR11	GGR41L06B100	4.1	4	0.05	31	6	3.8	1.00	1.00
GGR12	GGR41L06B150	4.1	4	0.05	31	6	3.8	1.00	1.50
GGR13	GGR41L12B050	4.1	4	0.05	37	12	3.8	1.00	0.50
GGR14	GGR41L12B075	4.1	4	0.05	37	12	3.8	1.00	0.75
GGR15	GGR41L12B100	4.1	4	0.05	37	12	3.8	1.00	1.00
GGR16	GGR41L12B150	4.1	4	0.05	37	12	3.8	1.00	1.50
GGR17	GGR51L08B100	5.1	5	0.10	33	8	4.8	1.50	1.00
GGR18	GGR51L08B150	5.1	5	0.10	33	8	4.8	1.50	1.50
GGR19	GGR51L08B200	5.1	5	0.10	33	8	4.8	1.50	2.00
GGR20	GGR51L15B100	5.1	5	0.10	40	15	4.8	1.50	1.00
GGR21	GGR51L15B150	5.1	5	0.10	40	15	4.8	1.50	1.50
GGR22	GGR51L15B200	5.1	5	0.10	40	15	4.8	1.50	2.00
GGR23	GGR61L10B100	6.1	6	0.10	35	10	5.8	2.00	1.00
GGR24	GGR61L10B150	6.1	6	0.10	35	10	5.8	2.00	1.50
GGR25	GGR61L10B200	6.1	6	0.10	35	10	5.8	2.00	2.00
GGR26	GGR61L20B100	6.1	6	0.10	45	20	5.8	2.00	1.00
GGR27	GGR61L20B150	6.1	6	0.10	45	20	5.8	2.00	1.50
GGR28	GGR61L20B200	6.1	6	0.10	45	20	5.8	2.00	2.00
GGR29	GGR71L25B100	7.1	7	0.10	54	25	6.8	2.00	1.00
GGR30	GGR71L25B150	7.1	7	0.10	54	25	6.8	2.00	1.50
GGR31	GGR71L25B200	7.1	7	0.10	54	25	6.8	2.00	2.00



**塗層說明 Coating item**

塗層編號 Coated item	顏色 Color	加工材料 Application	特性參數 Performance parameter
AD12	Black 黑色 	黏性材料專用，鋁材、壓克力、聚乙烯、碳纖維材料 For viscous materials, aluminum, acrylic, polyethylene, carbon fiber materials	Nano Hardness :HV2200, Friction Coefficient: 0.2 Max.Temp: 400°
AT12	Gold 金色 	泛用於HRC45以內材料，包括以下材料:不銹鋼,303,316F, 鎳不銹鋼等；鋼材（淬火鋼、鉻鉬鋼、錳鋼等碳鋼）；生鐵、鑄鐵、鎳合金、壓克力 Universally used for materials within HRC45, include the following materials : stainless steel, 303, 316F, Nickel stainless steel, etc.; steel hardened steel, molybdenum steel, fierce steel and other carbon steel; Pig iron, cast iron, nickel alloy, acrylic	Nano Hardness :HV3500 Friction Coefficient: 0.3 Max.Temp: 900°
AL25	Blue Grey 黑藍色 	低碳材料，純鐵、低碳鋼、低碳不銹鋼，比如304不銹鋼 Low carbon materials, pure iron, low carbon steel and low carbon stainless steel, such as 304 stainless steel	Nano Hardness :HV3500, Friction Coefficient: 0.25 Max.Temp: 800°
AT25	Black 黑色 	碳素鋼、合金鋼、軸承鋼、淬火鋼、鉻鉬鋼、錳鋼 Carbon steel, alloy steel, bearing steel, hardened steel, Cr-Mo steel, manganese steel	Nano Hardness :HV3500, Friction Coefficient: 0.6 Max.Temp: 900°
JS25	Bronze 古銅色 	泛用於HRC60以內材料，包括以下材料:奧氏體/馬氏體不銹鋼,316L,303,321,316F,高鎳不銹鋼等；鋼材（軸承鋼，淬火鋼，鉻鉬合金鋼，錳鋼等高碳鋼）；生鐵，鑄鐵，鎳合金等。 Widely used in materials within HRC60, include the following materials: austenitic/martensitic stainless steel,316L, 303, 321, 316F, high nickel stainless steel, etc.; steel (bearing steel, hardened steel, pig iron, Chromium-molybdenum alloy steel,high carbon steel such as manganese steel) cast iron,nickel alloy, etc.	Nano Hardness :HV4500, Friction Coefficient: 0.4 Max.Temp: 1100°
TZ25	Champagne Gold 香檳金色 	鈦合金專用 Special use for titanium alloy.	Nano Hardness :HV4000 Friction Coefficient: 0.55 Max.Temp: 900°

**OBH 內孔刀刀柄 Internal hole knife handle**

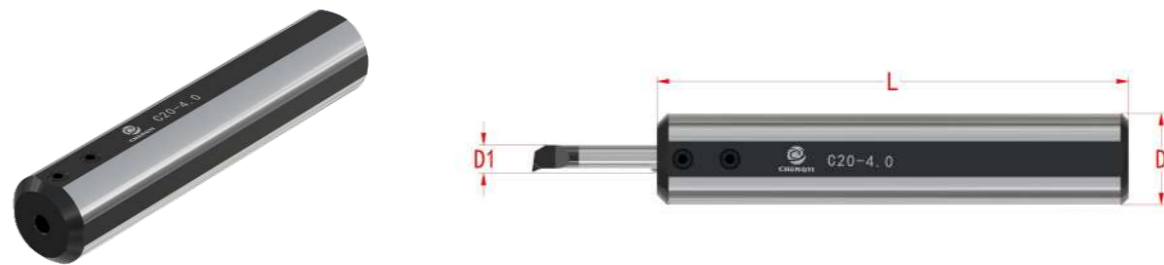

訂購代號 Code	產品型號 Product model	D	D1	L
OBH01	OBH1905-D03	19.05	3	100
OBH02	OBH1905-D04	19.05	4	100
OBH03	OBH1905-D05	19.05	5	100
OBH04	OBH1905-D06	19.05	6	100
OBH05	OBH1905-D08	19.05	8	100
OBH06	OBH1905-D10	19.05	10	100
OBH07	OBH1905-D12	19.05	12	100
OBH08	OBH2000-D03	20	3	100
OBH09	OBH2000-D04	20	4	100
OBH10	OBH2000-D05	20	5	100
OBH11	OBH2000-D06	20	6	100
OBH12	OBH2000-D08	20	8	100
OBH13	OBH2000-D10	20	10	100
OBH14	OBH2000-D12	20	12	100
OBH15	OBH2200-D03	22	3	100
OBH16	OBH2200-D04	22	4	100
OBH17	OBH2200-D05	22	5	100
OBH18	OBH2200-D06	22	6	100
OBH19	OBH2200-D08	22	8	100
OBH20	OBH2200-D10	22	10	100
OBH21	OBH2200-D12	22	12	100
OBH22	OBH2200-D16	22	16	100
OBH23	OBH2500-D03	25	3	100
OBH24	OBH2500-D04	25	4	100
OBH25	OBH2500-D05	25	5	100
OBH26	OBH2500-D06	25	6	100
OBH27	OBH2500-D08	25	8	100
OBH28	OBH2500-D10	25	10	100
OBH29	OBH2500-D12	25	12	100
OBH30	OBH2500-D16	25	16	100
OBH31	OBH2540-D03	25.4	3	100
OBH32	OBH2540-D04	25.4	4	100
OBH33	OBH2540-D05	25.4	5	100
OBH34	OBH2540-D06	25.4	6	100
OBH35	OBH2540-D08	25.4	8	100
OBH36	OBH2540-D10	25.4	10	100
OBH37	OBH2540-D12	25.4	12	100
OBH38	OBH2540-D16	25.4	16	100

## JPR 仿型內孔刀 Profiling inner hole knife

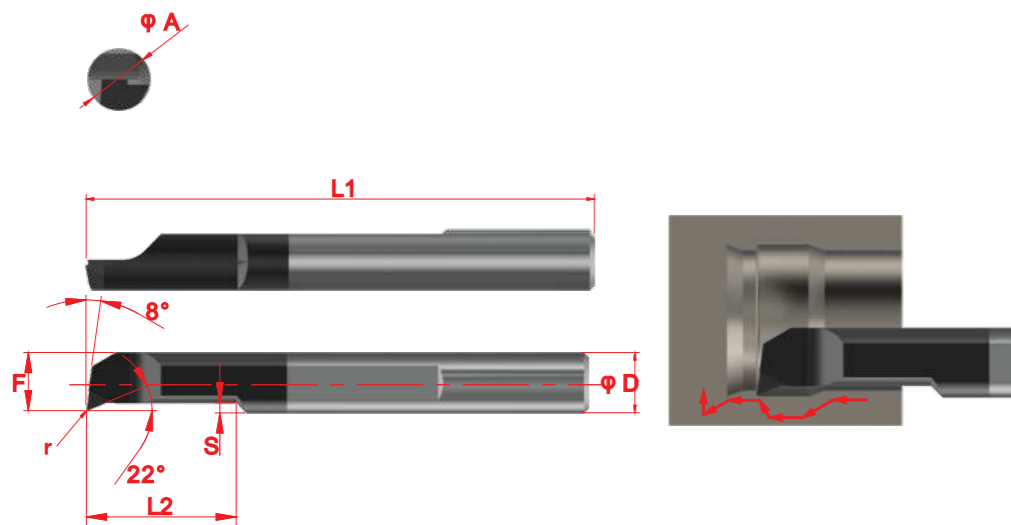

訂購代號 Code	產品型號 Product model	最小加工直徑 Min dia(mm)ØA	ØD	r	L1	L2	F	S
JPR01	JPR10L04R005	1.0	4	0.05	40	4	0.9	0.15
JPR02	JPR12L04R005	1.2	4	0.05	40	4	1.1	0.15
JPR03	JPR15L05R005	1.5	4	0.05	40	5	1.4	0.20
JPR04	JPR15L05R010	1.5	4	0.10	40	5	1.4	0.20
JPR05	JPR15L08R005	1.5	4	0.05	40	8	1.4	0.20
JPR06	JPR15L08R010	1.5	4	0.10	40	8	1.4	0.20
JPR07	JPR18L05R005	1.8	4	0.05	40	5	1.7	0.20
JPR08	JPR18L05R010	1.8	4	0.10	40	5	1.7	0.20
JPR09	JPR18L09R005	1.8	4	0.05	40	9	1.7	0.20
JPR10	JPR18L09R010	1.8	4	0.10	40	9	1.7	0.20
JPR11	JPR21L06R005	2.1	4	0.05	40	6	1.85	0.25
JPR12	JPR21L06R010	2.1	4	0.10	40	6	1.85	0.25
JPR13	JPR21L10R005	2.1	4	0.05	40	10	1.85	0.25
JPR14	JPR21L10R010	2.1	4	0.10	40	10	1.85	0.25
JPR15	JPR26L08R005	2.6	4	0.05	40	8	2.35	0.30
JPR16	JPR26L08R010	2.6	4	0.10	40	8	2.35	0.30
JPR17	JPR26L08R015	2.6	4	0.15	40	8	2.35	0.30
JPR18	JPR26L12R005	2.6	4	0.05	40	12	2.35	0.30
JPR19	JPR26L12R010	2.6	4	0.10	40	12	2.35	0.30
JPR20	JPR26L12R015	2.6	4	0.15	40	12	2.35	0.30
JPR21	JPR31L10R005	3.1	4	0.05	40	10	2.8	0.50
JPR22	JPR31L10R010	3.1	4	0.10	40	10	2.8	0.50
JPR23	JPR31L10R015	3.1	4	0.15	40	10	2.8	0.50
JPR24	JPR31L15R005	3.1	4	0.05	45	15	2.8	0.50
JPR25	JPR31L15R010	3.1	4	0.10	45	15	2.8	0.50
JPR26	JPR31L15R015	3.1	4	0.15	45	15	2.8	0.50
JPR27	JPR41L12R005	4.1	4	0.05	45	12	3.8	0.60

## JPR 仿型內孔刀 Profiling inner hole knife

訂購代號 Code	產品型號 Product model	最小加工直徑 Min dia(mm)ØA	ØD	r	L1	L2	F	S
JPR28	JPR41L12R010	4.1	4	0.10	45	12	3.8	0.60
JPR29	JPR41L12R020	4.1	4	0.20	45	12	3.8	0.60
JPR30	JPR41L16R005	4.1	4	0.05	45	16	3.8	0.60
JPR31	JPR41L16R010	4.1	4	0.10	45	16	3.8	0.60
JPR32	JPR41L16R020	4.1	4	0.20	45	16	3.8	0.60
JPR33	JPR41L20R005	4.1	4	0.05	50	20	3.8	0.60
JPR34	JPR41L20R010	4.1	4	0.10	50	20	3.8	0.60
JPR35	JPR41L20R020	4.1	4	0.20	50	20	3.8	0.60
JPR36	JPR51L15R005	5.1	5	0.05	50	15	4.8	0.80
JPR37	JPR51L15R010	5.1	5	0.10	50	15	4.8	0.80
JPR38	JPR51L15R020	5.1	5	0.20	50	15	4.8	0.80
JPR39	JPR51L20R005	5.1	5	0.05	54	20	4.8	0.80
JPR40	JPR51L20R010	5.1	5	0.10	54	20	4.8	0.80
JPR41	JPR51L20R020	5.1	5	0.20	54	20	4.8	0.80
JPR42	JPR51L25R005	5.1	5	0.05	60	25	4.8	0.80
JPR43	JPR51L25R010	5.1	5	0.10	60	25	4.8	0.80
JPR44	JPR51L25R020	5.1	5	0.20	60	25	4.8	0.80
JPR45	JPR61L15R005	6.1	6	0.05	50	15	5.8	1.00
JPR46	JPR61L15R010	6.1	6	0.10	50	15	5.8	1.00
JPR47	JPR61L15R020	6.1	6	0.20	50	15	5.8	1.00
JPR48	JPR61L22R005	6.1	6	0.05	60	22	5.8	1.00
JPR49	JPR61L22R010	6.1	6	0.10	60	22	5.8	1.00
JPR50	JPR61L22R020	6.1	6	0.20	60	22	5.8	1.00
JPR51	JPR61L30R005	6.1	6	0.05	65	30	5.8	1.00
JPR52	JPR61L30R010	6.1	6	0.10	65	30	5.8	1.00
JPR53	JPR61L30R020	6.1	6	0.20	65	30	5.8	1.00
JPR54	JPR71L25R010	7.1	7	0.10	65	25	6.8	1.20
JPR55	JPR71L25R020	7.1	7	0.20	65	25	6.8	1.20
JPR56	JPR71L30R010	7.1	7	0.10	70	30	6.8	1.20
JPR57	JPR71L30R020	7.1	7	0.20	70	30	6.8	1.20
JPR58	JTR81L30R010	8.1	8	0.10	65	30	7.8	1.50
JPR59	JTR81L30R020	8.1	8	0.20	65	30	7.8	1.50
JPR60	JTR81L40R020	8.1	8	0.20	75	40	7.8	1.50

## JTR 內孔刀 Internal boring knife

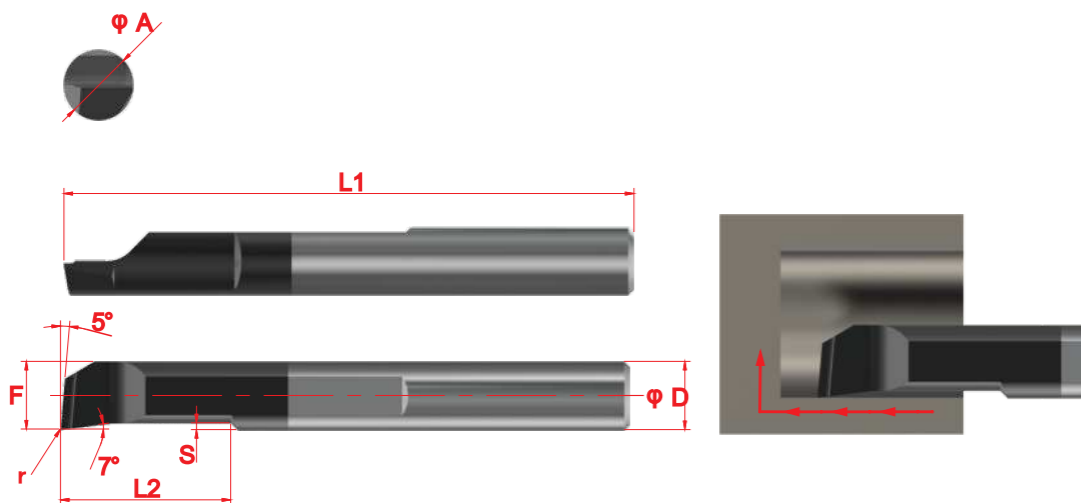

訂購代號 Code	產品型號 Product model	最小加工直徑 Min dia(mm)ØA	ØD	r	L1	L2	F	S
JTR01	JTR10L04R005	1.0	4	0.05	40	4	0.9	0.10
JTR02	JTR15L05R005	1.5	4	0.05	40	5	1.4	0.15
JTR03	JTR15L05R010	1.5	4	0.10	40	5	1.4	0.15
JTR04	JTR15L08R005	1.5	4	0.05	40	8	1.4	0.15
JTR05	JTR15L08R010	1.5	4	0.10	40	8	1.4	0.15
JTR06	JTR21L06R005	2.1	4	0.05	40	6	1.85	0.20
JTR07	JTR21L06R010	2.1	4	0.10	40	6	1.85	0.20
JTR08	JTR21L10R005	2.1	4	0.05	40	10	1.85	0.20
JTR09	JTR21L10R010	2.1	4	0.10	40	10	1.85	0.20
JTR10	JTR26L08R005	2.6	4	0.05	40	8	2.35	0.25
JTR11	JTR26L08R010	2.6	4	0.10	40	8	2.35	0.25
JTR12	JTR26L08R015	2.6	4	0.15	40	8	2.35	0.25
JTR13	JTR26L12R005	2.6	4	0.05	40	12	2.35	0.25
JTR14	JTR26L12R010	2.6	4	0.10	40	12	2.35	0.25
JTR15	JTR26L12R015	2.6	4	0.15	40	12	2.35	0.25
JTR16	JTR31L10R005	3.1	4	0.05	40	10	2.8	0.30
JTR17	JTR31L10R010	3.1	4	0.10	40	10	2.8	0.30
JTR18	JTR31L10R015	3.1	4	0.15	40	10	2.8	0.30
JTR19	JTR31L15R005	3.1	4	0.05	45	15	2.8	0.30
JTR20	JTR31L15R010	3.1	4	0.10	45	15	2.8	0.30
JTR21	JTR31L15R015	3.1	4	0.15	45	15	2.8	0.30
JTR22	JTR36L15R015	3.6	4	0.15	45	15	3.3	0.35
JTR23	JTR36L20R015	3.6	4	0.15	50	20	3.3	0.35
JTR24	JTR41L12R005	4.1	4	0.05	45	12	3.8	0.40
JTR25	JTR41L12R010	4.1	4	0.10	45	12	3.8	0.40
JTR26	JTR41L12R020	4.1	4	0.20	45	12	3.8	0.40
JTR27	JTR41L16R005	4.1	4	0.05	45	16	3.8	0.40

## JTR 內孔刀 Internal boring knife

訂購代號 Code	產品型號 Product model	最小加工直徑 Min dia(mm)ØA	ØD	r	L1	L2	F	S
JTR28	JTR41L16R010	4.1	4	0.10	45	16	3.8	0.40
JTR29	JTR41L16R020	4.1	4	0.20	45	16	3.8	0.40
JTR30	JTR41L20R005	4.1	4	0.05	50	20	3.8	0.40
JTR31	JTR41L20R010	4.1	4	0.10	50	20	3.8	0.40
JTR32	JTR41L20R020	4.1	4	0.20	50	20	3.8	0.40
JTR33	JTR51L15R005	5.1	5	0.05	50	15	4.8	0.50
JTR34	JTR51L15R010	5.1	5	0.10	50	15	4.8	0.50
JTR35	JTR51L15R020	5.1	5	0.20	50	15	4.8	0.50
JTR36	JTR51L20R005	5.1	5	0.05	54	20	4.8	0.50
JTR37	JTR51L20R010	5.1	5	0.10	54	20	4.8	0.50
JTR38	JTR51L20R020	5.1	5	0.20	54	20	4.8	0.50
JTR39	JTR51L25R005	5.1	5	0.05	60	25	4.8	0.50
JTR40	JTR51L25R010	5.1	5	0.10	60	25	4.8	0.50
JTR41	JTR51L25R020	5.1	5	0.20	60	25	4.8	0.50
JTR42	JTR51L35R020	5.1	5	0.20	70	35	4.8	0.50
JTR43	JTR61L15R005	6.1	6	0.05	50	15	5.8	0.60
JTR44	JTR61L15R010	6.1	6	0.10	50	15	5.8	0.60
JTR45	JTR61L15R020	6.1	6	0.20	50	15	5.8	0.60
JTR46	JTR61L22R005	6.1	6	0.05	60	22	5.8	0.60
JTR47	JTR61L22R010	6.1	6	0.10	60	22	5.8	0.60
JTR48	JTR61L22R020	6.1	6	0.20	60	22	5.8	0.60
JTR49	JTR61L30R005	6.1	6	0.05	65	30	5.8	0.60
JTR50	JTR61L30R010	6.1	6	0.10	65	30	5.8	0.60
JTR51	JTR61L30R020	6.1	6	0.20	65	30	5.8	0.60
JTR52	JTR61L35R020	6.1	6	0.20	70	35	5.8	0.60
JTR53	JTR61L40R020	6.1	6	0.20	75	40	5.8	0.60
JTR54	JTR71L25R010	7.1	7	0.10	65	25	6.8	0.70
JTR55	JTR71L25R020	7.1	7	0.20	65	25	6.8	0.70
JTR56	JTR71L30R010	7.1	7	0.10	65	30	6.8	0.70
JTR57	JTR71L30R020	7.1	7	0.20	65	30	6.8	0.70
JTR58	JTR71L35R020	7.1	7	0.20	70	35	6.8	0.70
JTR59	JTR81L30R010	8.1	8	0.10	65	30	7.8	0.85
JTR60	JTR81L30R020	8.1	8	0.20	65	30	7.8	0.85
JTR61	JTR81L40R020	8.1	8	0.20	75	40	7.8	0.85

## JUR 仿型平底內孔刀 Profiling flat bottom internal hole knife

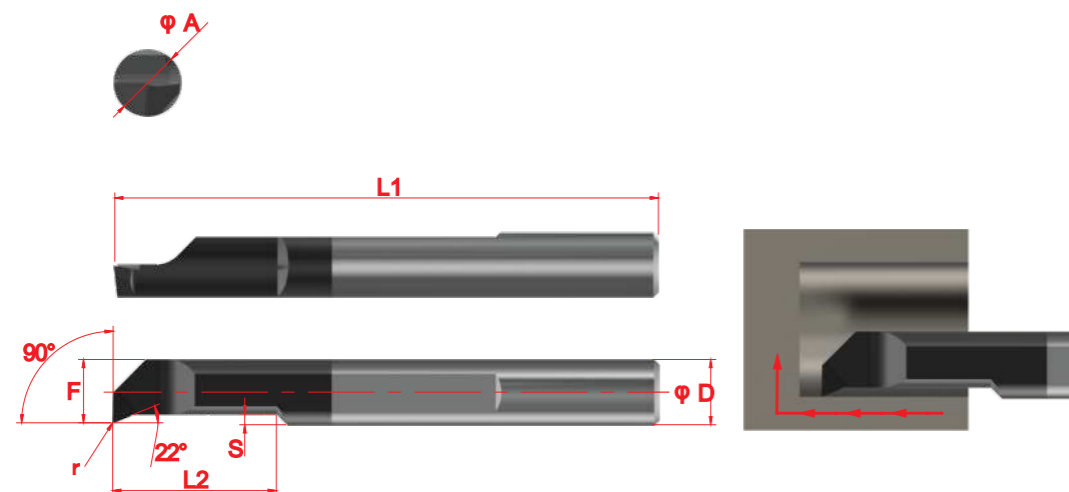

訂購代號 Code	產品型號 Product model	最小加工直徑 Min dia(mm)ØA	ØD	r	L1	L2	F	S
JUR01	JUR31L10R010	3.1	4	0.10	40	10	2.8	0.40
JUR02	JUR41L12R010	4.1	4	0.10	46	12	3.8	0.50
JUR03	JUR51L15R015	5.1	5	0.15	50	15	4.8	0.70
JUR04	JUR61L22R015	6.1	6	0.15	60	22	5.8	0.90

## JXR 反向內孔刀 Reverse internal bore knife

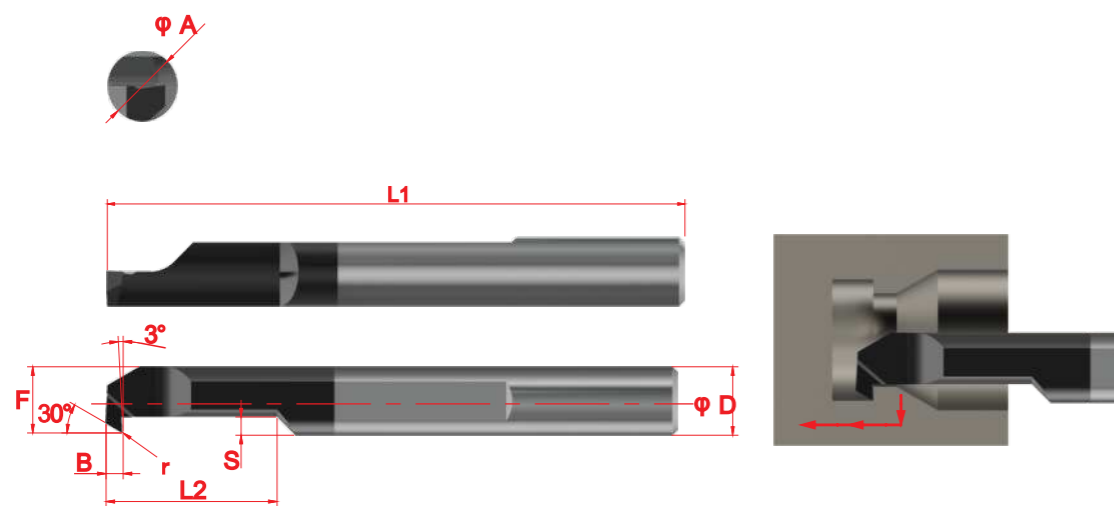

訂購代號 Code	產品型號 Product model	最小加工直徑 Min dia(mm)ØA	ØD	r	L1	L2	F	S	B
JXR01	JXR41L16R010	4.1	4	0.10	46	16	3.8	1.00	1.30
JXR02	JXR51L20R010	5.1	5	0.10	54	20	4.8	1.30	1.50
JXR03	JXR61L25R010	6.1	6	0.10	60	25	5.8	1.60	1.50

## JQR 仿型內孔刀 Profiling inner hole knife

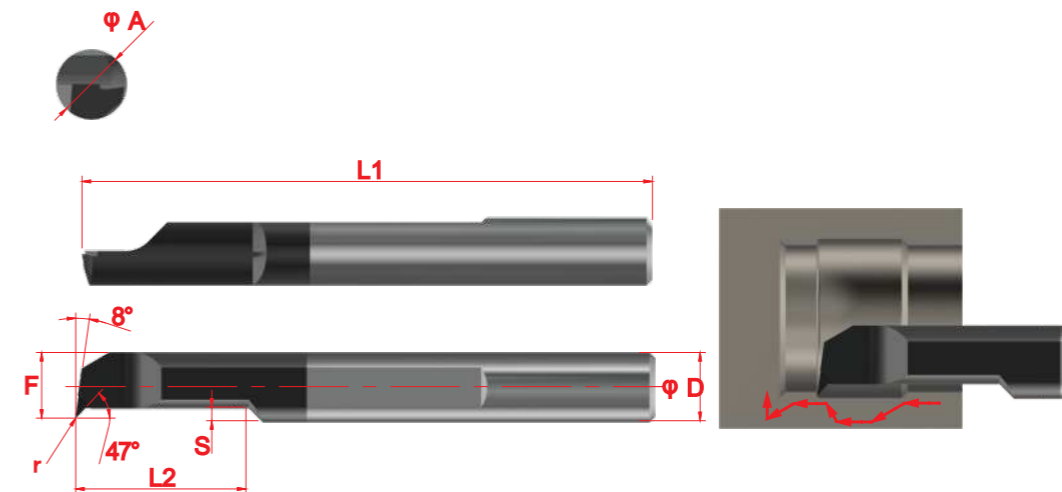

訂購代號 Code	產品型號 Product model	最小加工直徑 Min dia(mm)ØA	ØD	r	L1	L2	F	S
JQR01	JQR31L10R010	3.1	4	0.10	40	10	2.8	0.60
JQR02	JQR31L15R010	3.1	4	0.10	46	15	2.8	0.60
JQR03	JQR41L12R010	4.1	4	0.10	46	12	3.8	0.80
JQR04	JQR41L20R010	4.1	4	0.10	50	20	3.8	0.80
JQR05	JQR51L15R015	5.1	5	0.15	50	15	4.8	1.00
JQR06	JQR51L25R015	5.1	5	0.15	60	25	4.8	1.00
JQR07	JQR61L20R015	6.1	6	0.15	50	20	5.8	1.20
JQR08	JQR61L30R015	6.1	6	0.15	60	30	5.8	1.20
JQR09	JQR81L22R020	8.1	8	0.20	60	22	7.8	1.50
JQR10	JQR81L30R020	8.1	8	0.20	65	30	7.8	1.50

## JIR 60°內孔牙刀 60°Internal hole thread knife

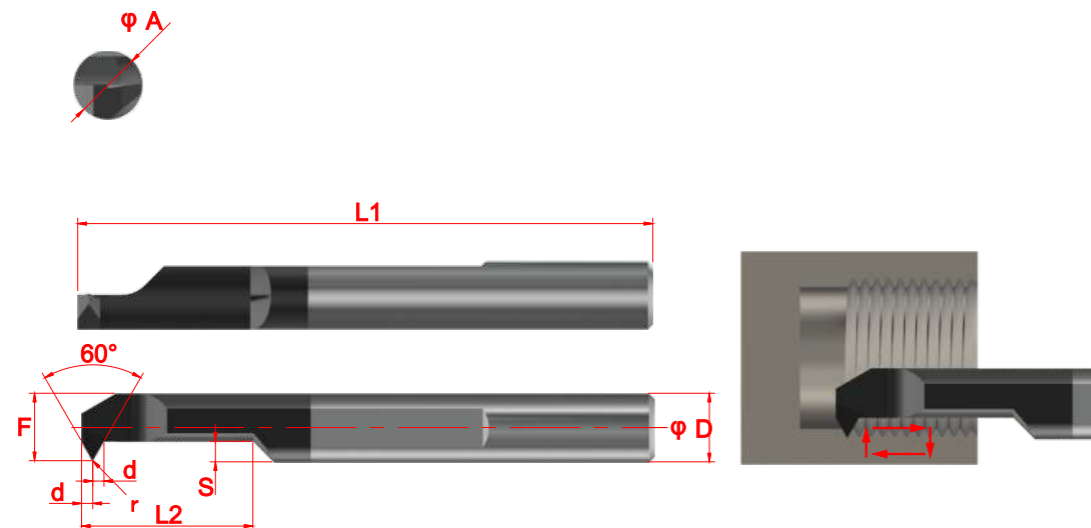

訂購代號 Code	產品型號 Product model	最小加工直徑 Min dia(mm)ØA	ØD	w	r	h	L1	L2	F	S	螺距範圍(mm) Pitch range
JIR01	JIR16L04A060	1.6	4	0.03	/	0.250	40	4	1.4	0.4	P0.25~P0.4
JIR02	JIR21L06A060	2.1	4	0.04	/	0.305	40	6	1.9	0.5	P0.3~P0.5
JIR03	JIR26L08A060	2.6	4	0.06	/	0.375	40	8	2.4	0.6	P0.4~P0.6
JIR04	JIR31L10A060	3.1	4	/	0.05	0.605	40	10	2.9	1.0	P0.5~P0.8
JIR05	JIR41L12A060X	4.1	4	/	0.05	0.720	46	12	3.9	1.2	P0.5~P1.0
JIR06	JIR41L12A060	4.1	4	/	0.10	0.750	46	12	3.9	1.2	P1.0~P1.5
JIR07	JIR51L15A060X	5.1	5	/	0.05	0.895	50	15	4.9	1.5	P0.5~P1.0
JIR08	JIR51L15A060	5.1	5	/	0.10	0.925	50	15	4.9	1.5	P1.0~P1.5
JIR09	JIR61L20A060X	6.1	6	/	0.05	1.070	60	20	5.9	1.8	P0.5~P1.0
JIR10	JIR61L20A060	6.1	6	/	0.10	1.095	60	20	5.9	1.8	P1.0~P1.75
JIR11	JIR81L25A060	8.1	8	/	0.10	1.330	65	25	7.9	2.2	P1.0~P2.0
JIR12	JIR81L30A060	8.1	8	/	0.10	1.330	65	30	7.9	2.2	P1.0~P2.0

※X表示可以加工更小的螺距，從0.4開始。X means that smaller pitches can be processed, starting from 0.4

## JIR 55°內孔牙刀 55°Internal hole thread knife

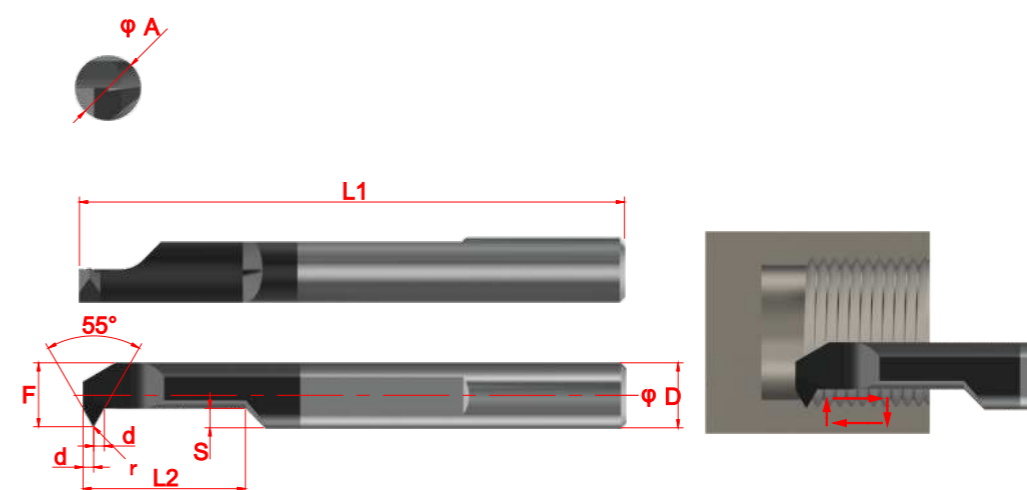

訂購代號 Code	產品型號 Product model	最小加工直徑 Min dia(mm)ØA	ØD	r	L1	L2	F	S	螺距範圍(mm) Pitch range
JIR13	JIR31L10A055	3.1	4	0.05	40	10	2.9	1.00	48-24
JIR14	JIR41L12A055	4.1	4	0.05	46	12	3.9	1.20	48-24
JIR15	JIR51L15A055	5.1	5	0.08	50	15	4.9	1.60	48-16
JIR16	JIR61L20A055	6.1	6	0.08	60	20	5.9	1.90	48-12
JIR17	JIR81L25A055	8.1	8	0.15	65	25	7.9	2.50	26-11
JIR18	JIR81L30A055	8.1	8	0.15	65	30	7.9	2.50	26-11

## JVR 深端面槽刀 Face grooving knife

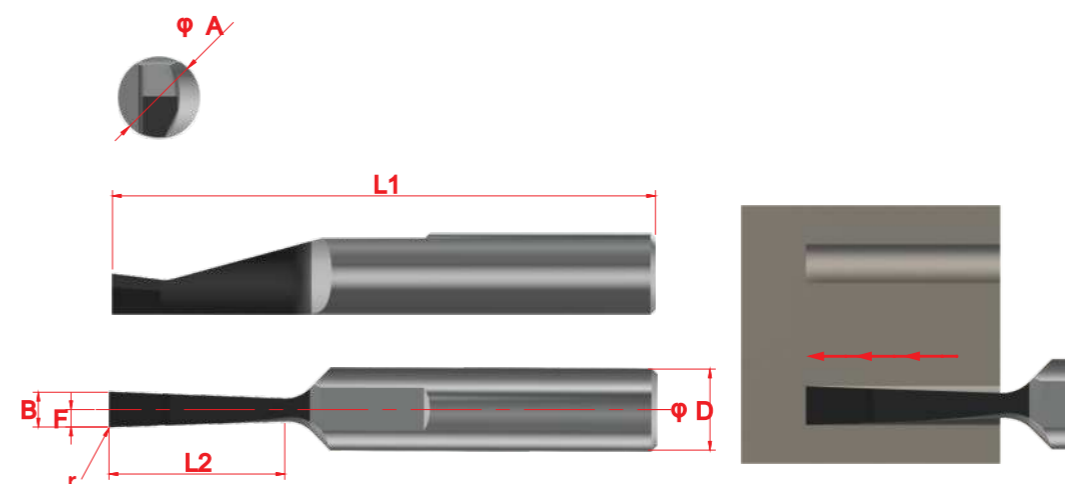

訂購代號 Code	產品型號 Product model	最小加工直徑 Min dia(mm)ØA	ØD	r	L1	L2	F	B
JVR01	JVR12L15B200	12.0	8	0.20	60	15	1.10	2.00
JVR02	JVR12L15B250	12.0	8	0.20	60	15	1.40	2.50
JVR03	JVR12L15B300	12.0	8	0.20	60	15	1.60	3.00

## JGR 內孔切槽刀 Internal grooving knife

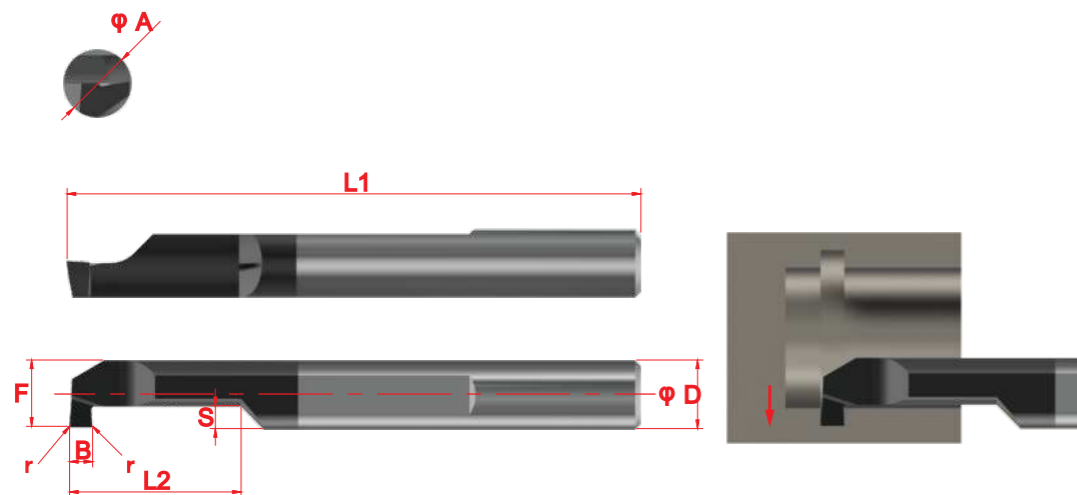

訂購代號 Code	產品型號 Product model	最小加工直徑 Min dia(mm)ØA	ØD	r	L1	L2	F	S	B
JGR01	JGR25L05B050	2.5	4	0.05	40	5	2.35	0.65	0.50
JGR02	JGR25L05B075	2.5	4	0.05	40	5	2.35	0.65	0.75
JGR03	JGR30L05B050	3.0	4	0.05	40	5	2.8	0.80	0.50
JGR04	JGR30L05B075	3.0	4	0.05	40	5	2.8	0.80	0.75
JGR05	JGR30L05B100	3.0	4	0.05	40	5	2.8	0.80	1.00
JGR06	JGR30L10B050	3.0	4	0.05	40	10	2.8	0.80	0.50
JGR07	JGR30L10B075	3.0	4	0.05	40	10	2.8	0.80	0.75
JGR08	JGR30L10B100	3.0	4	0.05	40	10	2.8	0.80	1.00
JGR09	JGR40L06B050	4.0	4	0.05	40	6	3.8	1.00	0.50
JGR10	JGR40L06B075	4.0	4	0.05	40	6	3.8	1.00	0.75
JGR11	JGR40L06B100	4.0	4	0.05	40	6	3.8	1.00	1.00
JGR12	JGR40L06B150	4.0	4	0.05	40	6	3.8	1.00	1.50
JGR13	JGR40L12B050	4.0	4	0.05	46	12	3.8	1.00	0.50
JGR14	JGR40L12B075	4.0	4	0.05	46	12	3.8	1.00	0.75
JGR15	JGR40L12B100	4.0	4	0.05	46	12	3.8	1.00	1.00
JGR16	JGR40L12B150	4.0	4	0.05	46	12	3.8	1.00	1.50
JGR17	JGR50L08B100	5.0	5	0.10	45	8	4.8	1.50	1.00
JGR18	JGR50L08B150	5.0	5	0.10	45	8	4.8	1.50	1.50
JGR19	JGR50L08B200	5.0	5	0.10	45	8	4.8	1.50	2.00
JGR20	JGR50L15B100	5.0	5	0.10	50	15	4.8	1.50	1.00
JGR21	JGR50L15B150	5.0	5	0.10	50	15	4.8	1.50	1.50
JGR22	JGR50L15B200	5.0	5	0.10	50	15	4.8	1.50	2.00
JGR23	JGR60L10B100	6.0	6	0.10	50	10	5.8	2.00	1.00
JGR24	JGR60L10B150	6.0	6	0.10	50	10	5.8	2.00	1.50
JGR25	JGR60L10B200	6.0	6	0.10	50	10	5.8	2.00	2.00
JGR26	JGR60L20B100	6.0	6	0.10	60	20	5.8	2.00	1.00
JGR27	JGR60L20B150	6.0	6	0.10	60	20	5.8	2.00	1.50

## JGR 內孔切槽刀 Internal grooving knife

訂購代號 Code	產品型號 Product model	最小加工直徑 Min dia(mm)ØA	ØD	r	L1	L2	F	S	B
JGR28	JGR60L20B200	6.0	6	0.10	60	20	5.8	2.00	2.00
JGR29	JGR70L22B100	7.0	7	0.10	62	22	6.8	2.00	1.00
JGR30	JGR70L22B150	7.0	7	0.10	62	22	6.8	2.50	1.50
JGR31	JGR70L22B200	7.0	7	0.10	62	22	6.8	2.50	2.00
JGR32	JGR80L22B100	8.0	8	0.10	64	22	7.8	1.80	1.00
JGR33	JGR80L25B150	8.0	8	0.10	65	25	7.8	2.50	1.50
JGR34	JGR80L25B200	8.0	8	0.10	65	25	7.8	2.50	2.00
JGR35	JGR80L25B250	8.0	8	0.10	65	25	7.8	2.50	2.50

## JFR 端面槽刀 Face grooving knife

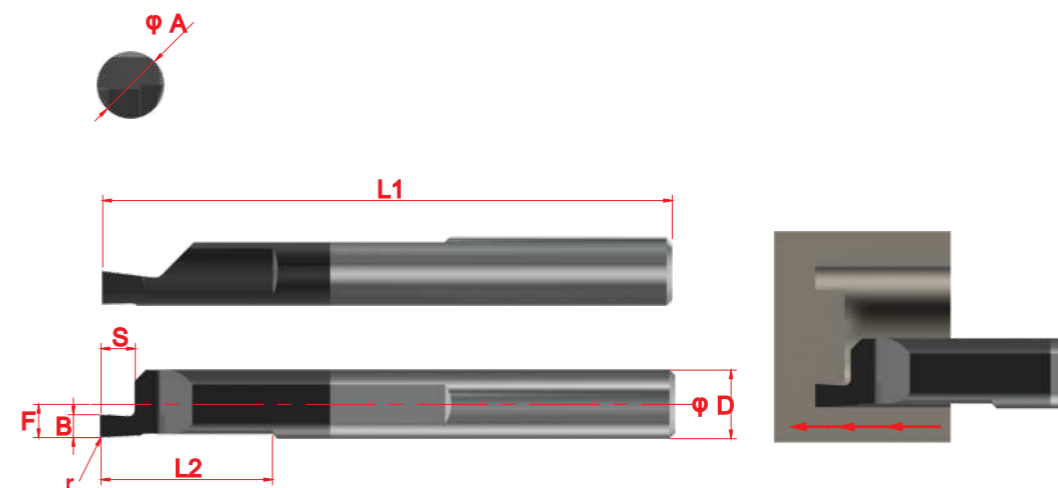

訂購代號 Code	產品型號 Product model	最小加工直徑 Min dia(mm)ØA	ØD	r	L1	L2	F	S	B
JFR01	JFR05L12B050	5.0	4	0.05	40	12	1.9	1.00	0.50
JFR02	JFR05L12B100	5.0	4	0.05	40	12	1.9	1.50	1.00
JFR03	JFR05L12B150	5.0	4	0.05	40	12	1.9	2.00	1.50
JFR04	JFR06L15B100	6.0	5	0.10	50	15	2.4	1.50	1.00
JFR05	JFR06L15B150	6.0	5	0.10	50	15	2.4	2.50	1.50
JFR06	JFR06L15B200	6.0	5	0.10	50	15	2.4	3.00	2.00
JFR07	JFR08L20B100	8.0	6	0.10	50	20	2.9	2.00	1.00
JFR08	JFR08L20B150	8.0	6	0.10	50	20	2.9	2.50	1.50
JFR09	JFR08L20B200	8.0	6	0.10	50	20	2.9	3.00	2.00
JFR10	JFR08L20B300	8.0	6	0.10	50	20	2.9	4.50	3.00
JFR11	JFR10L22B250	10.0	8	0.10	60	22	3.9	3.50	2.50

### 鎢鋼鑽頭(CDB系列) Carbide drill bit(CDB series)

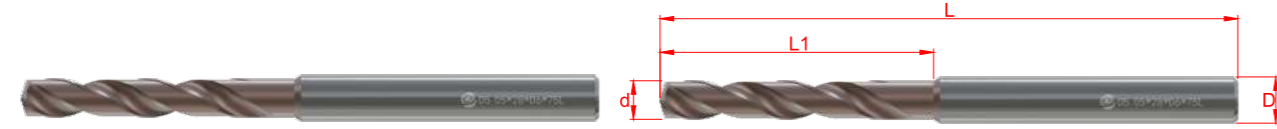

訂購代號 Code	直徑 d	刃長 L1	柄徑 D	全長 L
CDB200	2	12	3	50
CDB205	2.05	12	3	50
CDB210	2.1	12	3	50
CDB215	2.15	12	3	50
CDB220	2.2	12	3	50
CDB225	2.25	12	3	50
CDB230	2.3	12	3	50
CDB235	2.35	12	3	50
CDB238	2.38	12	3	50
CDB240	2.4	12	3	50
CDB245	2.45	12	3	50
CDB250	2.5	12	3	50
CDB255	2.55	16	3	50
CDB260	2.6	16	3	50
CDB265	2.65	16	3	50
CDB270	2.7	16	3	50
CDB275	2.75	16	3	50
CDB278	2.78	16	3	50
CDB280	2.8	16	3	50
CDB285	2.85	16	3	50
CDB290	2.9	16	3	50
CDB295	2.95	16	3	50
CDB300	3	16	3	50
CDB305	3.05	18	4	60
CDB310	3.1	18	4	60
CDB315	3.15	18	4	60
CDB320	3.2	18	4	60
CDB325	3.25	18	4	60
CDB330	3.3	18	4	60
CDB335	3.35	18	4	60
CDB340	3.4	18	4	60
CDB345	3.45	18	4	60
CDB350	3.5	20	4	60
CDB355	3.55	20	4	60
CDB360	3.6	20	4	60
CDB365	3.65	20	4	60
CDB368	3.68	20	4	60
CDB370	3.7	20	4	60
CDB375	3.75	20	4	60
CDB380	3.8	20	4	60
CDB385	3.85	20	4	60
CDB390	3.9	20	4	60
CDB395	3.95	20	4	60
CDB400	4	20	4	60
CDB405	4.05	22	5	65
CDB410	4.1	22	5	65
CDB415	4.15	22	5	65
CDB420	4.2	22	5	65

訂購代號 Code	直徑 d	刃長 L1	柄徑 D	全長 L
CDB425	4.25	22	5	65
CDB430	4.3	22	5	65
CDB435	4.35	22	5	65
CDB440	4.4	24	5	65
CDB445	4.45	24	5	65
CDB450	4.5	24	5	65
CDB455	4.55	24	5	65
CDB460	4.6	24	5	65
CDB465	4.65	26	5	65
CDB470	4.7	26	5	65
CDB475	4.75	26	5	65
CDB480	4.8	26	5	65
CDB485	4.85	26	5	65
CDB490	4.9	26	5	65
CDB495	4.95	26	5	65
CDB500	5	26	5	65
CDB505	5.05	28	6	70
CDB510	5.1	28	6	70
CDB515	5.15	28	6	70
CDB520	5.2	28	6	70
CDB525	5.25	28	6	70
CDB530	5.3	28	6	70
CDB535	5.35	28	6	70
CDB540	5.4	28	6	70
CDB545	5.45	28	6	70
CDB550	5.5	28	6	70
CDB555	5.55	28	6	70
CDB560	5.6	30	6	70
CDB565	5.65	30	6	70
CDB570	5.7	30	6	70
CDB575	5.75	30	6	70
CDB580	5.8	30	6	70
CDB585	5.85	30	6	70
CDB590	5.9	30	6	70
CDB595	5.95	30	6	70
CDB600	6	30	6	70
CDB605	6.05	35	7	75
CDB610	6.1	35	7	75
CDB615	6.15	35	7	75
CDB620	6.2	35	7	75
CDB625	6.25	35	7	75
CDB630	6.3	35	7	75
CDB635	6.35	35	7	75
CDB640	6.4	35	7	75
CDB645	6.45	35	7	75
CDB650	6.5	35	7	75
CDB655	6.55	35	7	75
CDB660	6.6	35	7	75

### 鎢鋼鑽頭(CDB系列) Carbide drill bit(CDB series)

訂購代號 Code	直徑 d	刃長 L1	柄徑 D	全長 L
CDB665	6.65	35	7	75
CDB670	6.7	35	7	75
CDB675	6.75	35	7	75
CDB680	6.8	35	7	75
CDB685	6.85	35	7	75
CDB690	6.9	35	7	75
CDB695	6.95	35	7	75
CDB700	7	35	7	75
CDB705	7.05	35	8	80
CDB710	7.1	35	8	82
CDB715	7.15	37	8	82
CDB720	7.2	37	8	82
CDB725	7.25	37	8	82
CDB730	7.3	37	8	82
CDB735	7.35	37	8	82
CDB740	7.4	37	8	82
CDB745	7.45	37	8	82
CDB750	7.5	37	8	82
CDB755	7.55	37	8	82
CDB760	7.6	37	8	82
CDB765	7.65	40	8	82
CDB770	7.7	40	8	82
CDB775	7.75	40	8	82
CDB780	7.8	40	8	82
CDB785	7.85	40	8	82
CDB790	7.9	40	8	82
CDB795	7.95	40	8	82
CDB800	8	40	8	82
CDB805	8.05	40	8	82
CDB810	8.1	40	8	82
CDB815	8.15	40	9	82
CDB820	8.2	40	9	82
CDB825	8.25	40	9	82
CDB830	8.3	40	9	82
CDB835	8.35	40	9	82
CDB840	8.4	40	9	82
CDB845	8.45	40	9	82
CDB850	8.5	40	9	82
CDB855	8.55	40	9	82
CDB860	8.6	40	9	82
CDB865	8.65	40	9	82
CDB870	8.7	40	9	82
CDB875	8.75	40	9	82
CDB880	8.8	40	9	82
CDB885	8.85	40	9	82
CDB890	8.9	40	9	82

訂購代號 Code	直徑 d	刃長 L1	柄徑 D	全長 L
CDB895	8.95	40	9	82
CDB900	9	40	9	82
CDB910	9.1	40	10	90
CDB920	9.2	40	10	90
CDB930	9.3	45	10	90
CDB940	9.4	45	10	90
CDB950	9.5	45	10	90
CDB960	9.6	45	10	90
CDB970	9.7	45	10	90
CDB980	9.8	45	10	90
CDB990	9.9	45	10	90
CDB1000	10	45	10	90
CDB1010	10.1	45	10	90
CDB1020	10.2	45	10	90
CDB1030	10.3	45	10	90
CDB1040	10.4	45	10	90
CDB1050	10.5	45	10	90
CDB1060	10.6	45	10	90
CDB1070	10.7	45	10	90
CDB1080	10.8	45	10	90
CDB1090	10.9	45	10	90
CDB1100	11	45	10	90
CDB1110	11.1	45	10	90
CDB1120	11.2	45	10	90
CDB1130	11.3	45	10	90
CDB1140	11.4	45	10	90
CDB1150	11.5	45	10	90
CDB1160	11.6	45	10	90
CDB1170	11.7	45	10	90
CDB1180	11.8	45	10	90
CDB1190	11.9	45	10	90
CDB1200	12	45	10	90
CDB1210	12.1	45	10	90
CDB1220	12.2	45	10	90
CDB1230	12.3	45	10	90
CDB1240	12.4	45	10	90
CDB1250	12.5	45	10	90
CDB1260	12.6	45	10	90
CDB1270	12.7	45	10	90
CDB1280	12.8	45	10	90
CDB1290	12.9	45	10	90
CDB1300	13	45	10	90
CDB1350	13.5	45	14	95
CDB1400	14	45	14	95
CDB1450	14.5	45	15	95
CDB1500	15	45	15	95

**90°雙頭鎢鋼定點鑽(90°SPC系列) 90° double-headed carbide spot drill (90°SPC series)**

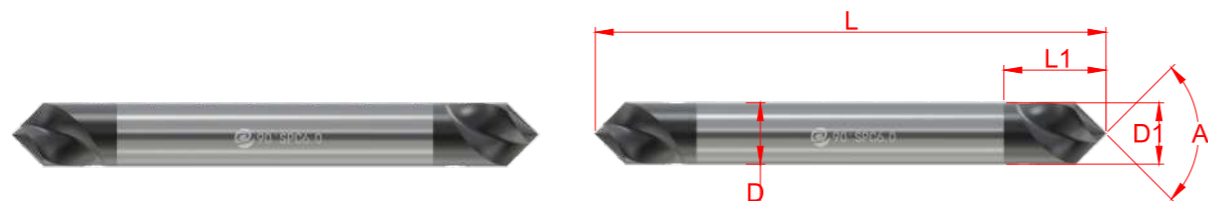

訂購代號 Code	型號 Model	刃徑 d	刃長 L1	柄徑 D	角度 A	全長 L
SPC01	60°SPC3.0	3	5	3	60°	50
SPC02	60°SPC4.0	4	6	4	60°	50
SPC03	60°SPC5.0	5	8	5	60°	50
SPC04	60°SPC6.0	6	8	6	60°	50
SPC05	60°SPC8.0	8	10	8	60°	50
SPC06	60°SPC10.0	10	10	10	60°	50
SPC07	90°SPC3.0	3	5	3	90°	50
SPC08	90°SPC4.0	4	6	4	90°	50
SPC09	90°SPC5.0	5	8	5	90°	50
SPC10	90°SPC6.0	6	8	6	90°	50
SPC11	90°SPC8.0	8	10	8	90°	50
SPC12	90°SPC10.0	10	10	10	90°	50
SPC13	120°SPC3.0	3	5	3	120°	50
SPC14	120°SPC4.0	4	6	4	120°	50
SPC15	120°SPC5.0	5	8	5	120°	50
SPC16	120°SPC6.0	6	8	6	120°	50
SPC17	120°SPC8.0	8	10	8	120°	50
SPC18	120°SPC10.0	10	10	10	120°	50

**90°雙頭鎢鋼雙角度定點鑽 (90°EPDC系列) 90° double-head carbide double-angle fixed point drill (90°EPDC series)**

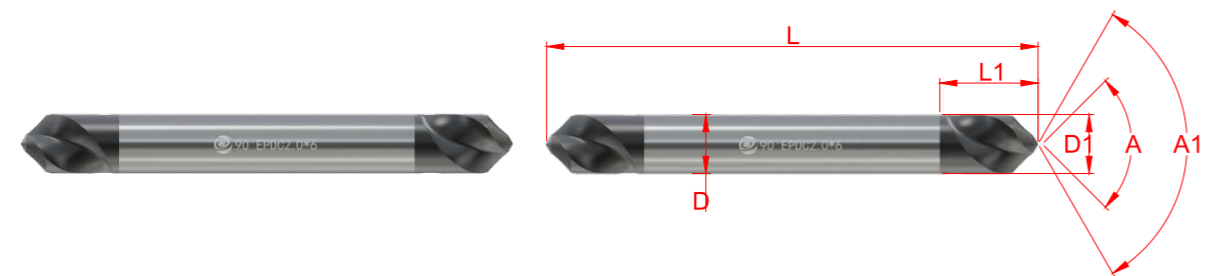

訂購代號 Code	型號 Model	刃徑 d	刃長 L1	柄徑 D	角度 A	角度 A1	全長 L
EPDC01	60°EPDC1.5*4	4	6	4	60°	120°	50
EPDC02	60°EPDC1.8*5	5	8	5	60°	120°	50
EPDC03	60°EPDC2.0*6	6	8	6	60°	120°	50
EPDC04	60°EPDC2.5*8	8	10	8	60°	120°	50
EPDC05	60°EPDC3.0*10	10	10	10	60°	120°	50
EPDC06	90°EPDC1.5*4	4	6	4	90°	120°	50
EPDC07	90°EPDC1.8*5	5	8	5	90°	120°	50
EPDC08	90°EPDC2.0*6	6	8	6	90°	120°	50
EPDC09	90°EPDC2.5*8	8	10	8	90°	120°	50
EPDC10	90°EPDC3.0*10	10	10	10	90°	120°	50

**無動力刀座 動力刀座**

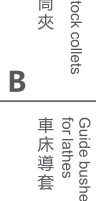

訂購代號 Code	型號 Model	刃徑 d	刃長 L1	柄徑 D	角度 A	全長 L
SPC01	60°SPC3.0	3	5	3	60°	50
SPC02	60°SPC4.0	4	6	4	60°	50
SPC03	60°SPC5.0	5	8	5	60°	50
SPC04	60°SPC6.0	6	8	6	60°	50
SPC05	60°SPC8.0	8	10	8	60°	50
SPC06	60°SPC10.0	10	10	10	60°	50
SPC07	90°SPC3.0	3	5	3	90°	50
SPC08	90°SPC4.0	4	6	4	90°	50
SPC09	90°SPC5.0	5	8	5	90°	50
SPC10	90°SPC6.0	6	8	6	90°	50
SPC11	90°SPC8.0	8	10	8	90°	50
SPC12	90°SPC10.0	10	10	10	90°	50
SPC13	120°SPC3.0	3	5	3	120°	50
SPC14	120°SPC4.0	4	6	4	120°	50
SPC15	120°SPC5.0	5	8	5	120°	50
SPC16	120°SPC6.0	6	8	6	120°	50
SPC17	120°SPC8.0	8	10	8	120°	50
SPC18	120°SPC10.0	10	10	10	120°	50

**90°雙頭鎢鋼雙角度定點鑽 (90°EPDC系列) 90° double-head carbide double-angle fixed point drill (90°EPDC series)**



訂購代號 Code	型號 Model	刃徑 d	刃長 L1	柄徑 D	角度 A	角度 A1	全長 L
EPDC01	60°EPDC1.5*4	4	6	4	60°	120°	50
EPDC02	60°EPDC1.8*5	5	8	5	60°	120°	50
EPDC03	60°EPDC2.0*6	6	8	6	60°	120°	50
EPDC04	60°EPDC2.5*8	8	10	8	60°	120°	50
EPDC05	60°EPDC3.0*10	10	10	10	60°	120°	50
EPDC06	90°EPDC1.5*4	4	6	4	90°	120°	50
EPDC07	90°EPDC1.8*5	5	8	5	90°	120°	50
EPDC08	90°EPDC2.0*6	6	8	6	90°	120°	50
EPDC09	90°EPDC2.5*8	8	10	8	90°	120°	50
EPDC10	90°EPDC3.0*10	10	10	10	90°	120°	50