

UC

BRAND NEW GOLD CHUCK
AN EXCITING RESULT.

—
一種全新感受的刀柄
創造令人振奮的成績





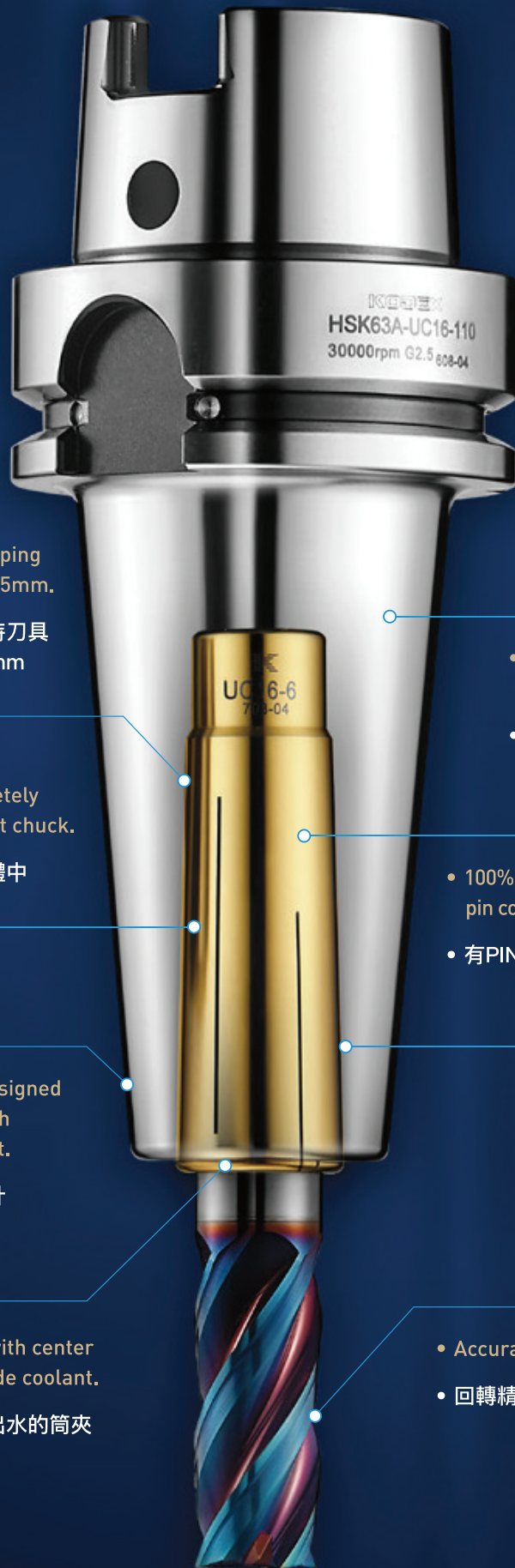

- Complete tool clamping range from 3mm~25mm.

- 規格種類齊全，夾持刀具的範圍：3mm~25mm

- The collet is completely covered in the collet chuck.

- 筒夾完全包覆在本體中

- The collet chuck designed without nut and with inner-holding collet.

- 沒有螺帽的刀柄設計

- Provide the collet with center coolant and with side coolant.

- 有中心出水及側面出水的筒夾可供選擇

- Excellent vibration damping of performance.

- 極佳的阻尼減震性能

- 100% never tool pull out for the pin collet.

- 有PIN的筒夾設計，100%不掉刀

- The inner-holding collet designed of small angle.

- 小角度的後拉式筒夾設計

- Accuracy < 0.005mm (4XD)

- 回轉精度在0.005mm以下 (4XD)

RUN OUT

Accuracy within 0.005mm at 4 times length of cutter edge to ensure uniform an even cutting action, increasing cutting speed and tool life.

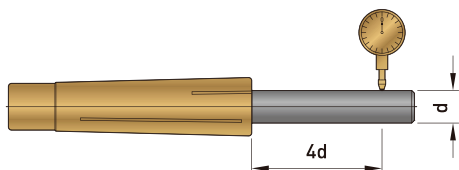

回轉精度

4倍刃長精度在0.005mm以內，確保切削時每刃刀口的均勻切削，可使切削速度提高及刀具壽命增加。

CHOICE OF COOLING MODE

Provide the collet with center coolant and with side coolant.

— 冷却方式的選擇

有中心出水及側面出水的筒夾，可供選擇。

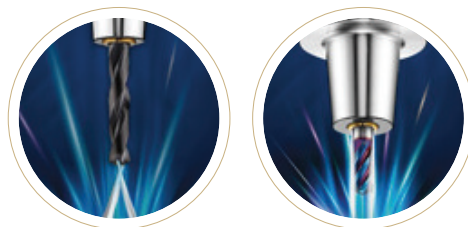

EXCELLENT VIBRATION DAMPING OF PERFORMANCE

The inner-holding collet designed of small angle can completely covered in the collet chuck that can increasing clamping force and having the excellent vibration damping of performance for get the maximum benefit from the machine and tools.



— 極佳的阻尼減震性能

小角度後拉式筒夾設計，筒夾完全包覆在本體內，鎖固力量大，具有極佳的阻尼減震性能，可使機床及刀具發揮到最大的效益。

INNOVATION DESIGNED AND 100% NEVER TOOL PULL OUT

The collet designed with pin can be fixed the standard side lock tool (DIN6535HB) or grinded R groove at tools with excellent vibration damping and 100% never tool pull out.

— 創新設計，100%不掉刀

有PIN的筒夾設計，可以固定標準側固刀具 [DIN6535HB] 或者自行在柄部研磨R型溝槽，具有極佳的阻尼減震及100%不掉刀的雙重效果。

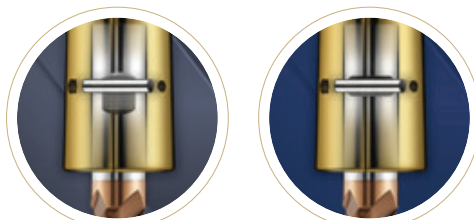

WELDON TYPE

R GROOVE

KOJEX IS THE INITIATOR OF INNER-HOLDING COLLET CHUCKS

The simple structure can reduces interference and more stable when the cutting processing.

— 廣傑獨創

沒有螺帽的筒夾設計
沒有螺帽的筒夾設計，結構簡單減少干涉，切削時更為安定。



COMPLETE VARIETY

Either the slim extension or the vibration damping tool holder has the clamping range from 3 mm to 25 mm.

— 規格種類齊全

無論小徑加長型或減震阻尼型均有，刀具夾持範圍：
3mm~25 mm



UC GOLD CHUCK

UC 黃金夾頭刀柄

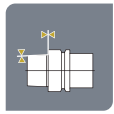
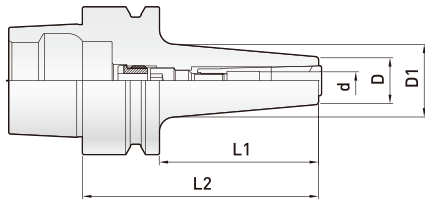

Dual face contact
兩面接觸



Surface roughness
表面粗度

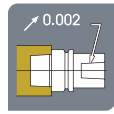

Run out accuracy
內孔偏擺度



Surface hardness
表面硬度

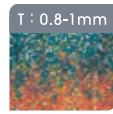

Carbonized depth
滲碳深度

| Order Code 訂購編號 | Range(d) 夾持範圍 | L | L1 | D | D1 | Min ⁻¹ G2.5 動態平衡 | Spanner 扳手規格 | Recommended Torsion 推薦鎖固扭力 | Fixed Torque Spanner 固定扭力扳手 |
|--------------------|------------------|----|----|----|----|--------------------------------|-----------------|-------------------------------|--------------------------------|
| HSK40E-UC6-80 | 3~6 | 80 | 60 | 16 | 26 | 42,000 | M4 | 5Nm | 30294-5144 |
| UC10-90 | 3~10 | 90 | 90 | 24 | 32 | 42,000 | M5 | 7Nm | 30294-5152 |
| HSK50E-UC6-80 | 3~6 | 80 | 54 | 16 | 25 | 36,000 | M4 | 5Nm | 30294-5144 |
| UC10-90 | 3~10 | 90 | 64 | 24 | 35 | 36,000 | M5 | 7Nm | 30294-5152 |

- Collet chuck designed without nut and with inner-holding collet. This has strong rigidity and high stability.
- Torque wrench is recommended for chuck stability.
- Torque wrench must be ordered separately.
- The recommended torsion and correct torque wrench prevents deformation of the tool holder.

- 沒有螺帽的後拉式夾頭設計，鋼性強穩定性高。
- 為求使用上的穩定性，建議使用扭力扳手。
- 扭力扳手必須另外訂購。
- 鎖固扭力不要超過推薦值的30%以上，過高的鎖固扭力，可能導致刀柄的變形。



UC GOLD CHUCK (Slim Long Type)

UC 黃金夾頭刀柄 (小徑加長型)

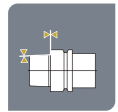
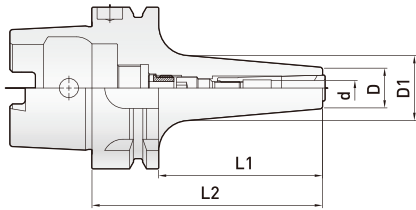

Dual face contact
兩面接觸



Surface roughness
表面粗度

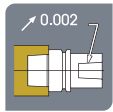

Run out accuracy
內孔偏擺度



Surface hardness
表面硬度

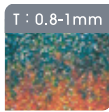

Carbonized depth
滲碳深度

| Order Code 訂購編號 | Range(d) 夾持範圍 | L | L1 | D | D1 | Min ¹ G2.5 動態平衡 | Spanner 扳手規格 | Recommended Torsion 推薦鎖固扭力 | Fixed Torque Spanner 固定扭力扳手 |
|--------------------|------------------|-----|-----|----|----|-------------------------------|-----------------|-------------------------------|--------------------------------|
| HSK63A-UC6-90 | 3~6 | 90 | 64 | 16 | 26 | 30,000 | M4 | 5Nm | 30294-5146 |
| UC6-120 | 3~6 | 120 | 94 | 16 | 32 | 30,000 | M4 | 5Nm | 30294-5146 |
| UC6-150 | 3~6 | 150 | 124 | 16 | 37 | 30,000 | M4 | 5Nm | 30294-5146 |
| HSK63A-UC10-100 | 3~10 | 100 | 74 | 24 | 34 | 30,000 | M5 | 7Nm | 30294-5154 |
| UC10-120 | 3~10 | 120 | 94 | 24 | 40 | 30,000 | M5 | 7Nm | 30294-5156 |
| UC10-150 | 3~10 | 150 | 124 | 24 | 46 | 30,000 | M5 | 7Nm | 30294-5156 |

- Collet chuck designed without nut and with inner-holding collet. This has strong rigidity and high stability.
- Torque wrench is recommended for chuck stability.
- Torque wrench must be ordered separately.
- The recommended torsion and correct torque wrench prevents deformation of the tool holder.

- 沒有螺帽的後拉式夾頭設計，鋼性強穩定性高。
- 為求使用上的穩定性，建議使用扭力扳手。
- 扭力扳手必須另外訂購。
- 鎖固扭力不要超過推薦值的30%以上，過高的鎖固扭力，可能導致刀柄的變形。



UC

HSK

A63

UC GOLD CHUCK (UC16) High Vibration Damping Type

UC 黃金夾頭刀柄 (UC16) 高阻尼減震型

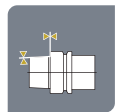
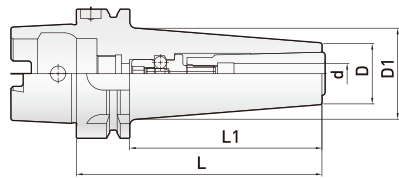

Dual face contact
兩面接觸

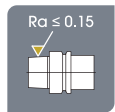

Surface roughness
表面粗度

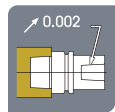

Run out accuracy
內孔偏擺度

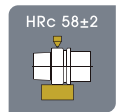

Surface hardness
表面硬度

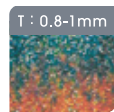

Carbonized depth
滲碳深度



| Order Code 訂購編號 | Range(d) 夾持範圍 | L | L1 | D | D1 | Min ⁻¹ G2.5 動態平衡 | Spanner 扳手規格 | Recommended Torsion 推薦鎖固扭力 | Torque Wrench 扭力扳手 | Center Coolant 中心出水 | Side Coolant 側面出水 | Pin Collet Pin 筒夾 |
|--------------------|------------------|-----|-----|----|----|--------------------------------|-----------------|-------------------------------|-----------------------|------------------------|----------------------|----------------------|
| HSK63A-UC16-120 | 6~16 | 120 | 94 | 32 | 47 | 30,000 | M6 | 15Nm | TW30+M06100 | ✓ | ✓ | X |
| HSK100A-UC16-150 | 6~16 | 150 | 121 | 32 | 49 | 20,000 | M6 | 15Nm | TW30+M06160 | ✓ | ✓ | X |

- Provide the center coolant and the side coolant.
- Select the side coolant must use the collet with coolant slot, please check p.20
- Select the general collet for center coolant, please check p.19
- Coolant can be sprayed directly into the edge of tool for quick cooling and remove the steel chip.
- 可以選擇中心出水及側面出水的功能。
- 側面出水必須選用有水槽的夾頭，請參閱 p.20
- 中心出水選用一般的夾頭，請參閱 p.19
- 冷卻液可直接噴到刀尖位置，可快速冷卻及去除鐵屑。



UC GOLD CHUCK (UC20) High Vibration Damping Type

UC 黃金夾頭刀柄 (UC20) 高阻尼減震型

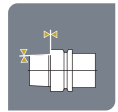
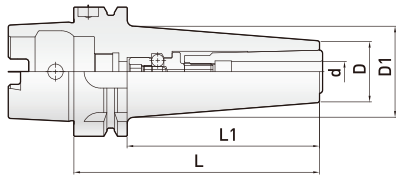

Dual face contact
兩面接觸



Surface roughness
表面粗度



Run out accuracy
內孔偏擺度



Surface hardness
表面硬度

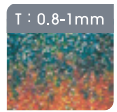

Carbonized depth
滲碳深度

| Order Code 訂購編號 | Range(d) 夾持範圍 | L | L1 | D | D1 | Min ⁻¹ G2.5 動態平衡 | Spanner 扳手規格 | Recommended Torsion 推薦鎖固扭力 | Torque Wrench 扭力扳手 | Center Coolant 中心出水 | Side Coolant 側面出水 | Pin Collet Pin筒夾 |
|--------------------|------------------|-----|-----|----|----|--------------------------------|-----------------|-------------------------------|-----------------------|------------------------|----------------------|---------------------|
| HSK63A-UC20-130 | 6~20 | 130 | 104 | 45 | 53 | 30,000 | M8 | 20Nm | TW30+M08100 | ✓ | ✓ | ✓ |
| HSK100A-UC20-150 | 6~20 | 150 | 121 | 45 | 54 | 20,000 | M8 | 20Nm | TW30+M08160 | ✓ | ✓ | ✓ |

- Provide the center coolant and the side coolant.
- Select the side coolant must use the collet with coolant slot, please check p.20
- Select the general collet for center coolant, please check p.19
- Select the PIN Collet, please check p.21
- Coolant can be sprayed directly into the edge of tool for quick cooling and remove the steel chip.

- 可以選擇中心出水及側面出水的功能。
- 側面出水必須選用有水槽的夾頭，請參閱 p.20
- 中心出水選用一般的夾頭，請參閱 p.19
- 可以選用PIN Collet，請參閱 p.21
- 冷卻液可直接噴到刀尖位置，可快速冷卻及去除鐵屑。



UC
20

HSK
A
63
/
100

UC PIN COLLET CHUCK (UC25) High Vibration Damping Type

UC 安卡夾頭 (UC25) 高阻尼減震型

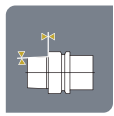
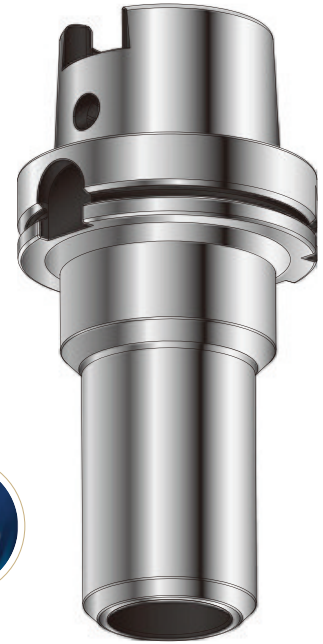
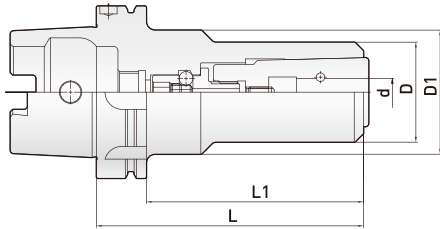

Dual face contact
兩面接觸



Surface roughness
表面粗度

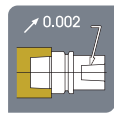

Run out accuracy
內孔偏擺度

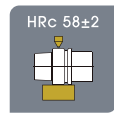

Surface hardness
表面硬度

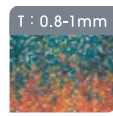

Carbonized depth
滲碳深度

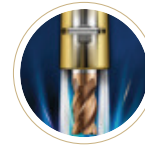

| Order Code 訂購編號 | Range(d) 夾持範圍 | L | L1 | D | D1 | Min ¹ G2.5 動態平衡 | Spanner 扳手規格 | Recommended Torsion 推薦鎖固扭力 | Torque Wrench 扭力扳手 |
|--------------------|------------------|-----|-----|----|----|-------------------------------|-----------------|-------------------------------|-----------------------|
| HSK100A-UC25-160 | 12-25 | 160 | 136 | 58 | 72 | 20,000 | M10 | 25Nm | TW30+M10100 |

- The collet designed with PIN, 100% never tool pull out.
- Must be used R groove tool or standard specifications DIN 6535 HB for side lock tool.
- Must to choose the Pin collet, please check p.21

- 有PIN的夾頭設計，100%不掉刀。
- 必須使用R型溝槽刀具或標準規範DIN 6535 HB的側固刀具。
- 必須選用有PIN的筒夾，請參閱 p.21



CENTER COOLANT

| 中心出水 |

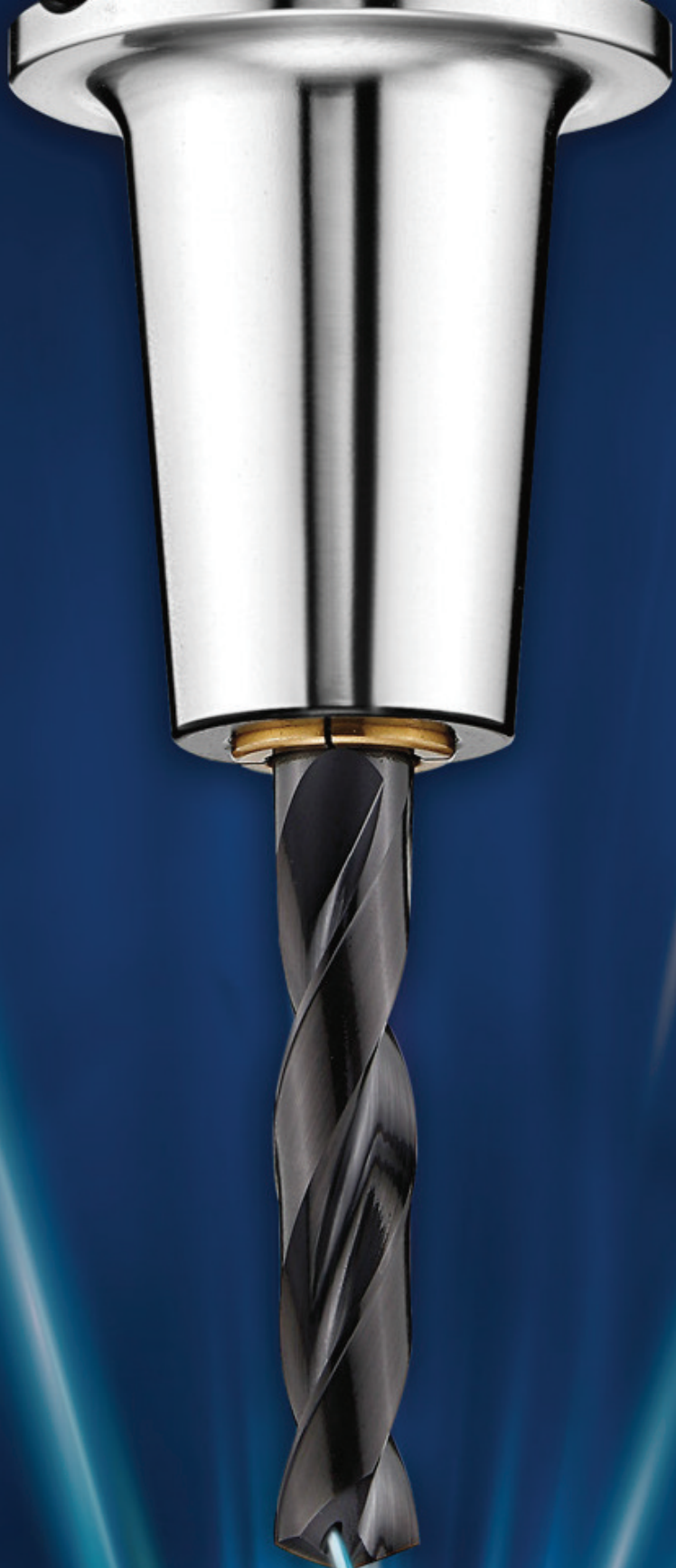

UC GOLD CHUCK (UC6) Slim Long Type

UC 黃金夾頭刀柄 (UC6) 小徑加長型

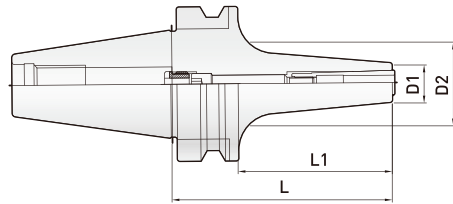
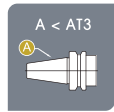
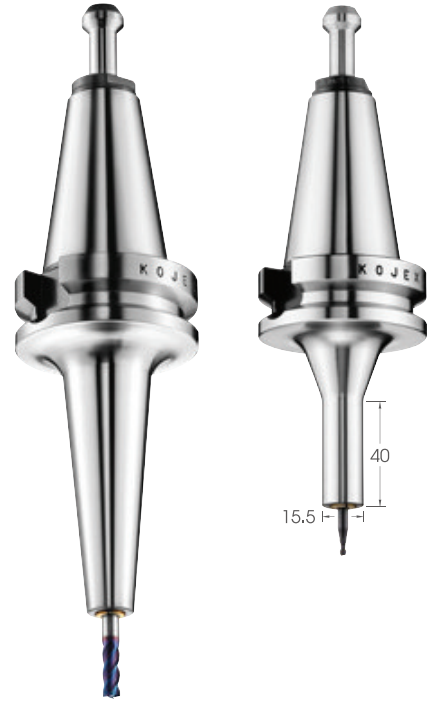
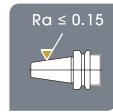

Fig 1 / 圖號 1

Fig 2 / 圖號 2



Taper tolerance
錐度公差



Surface roughness
表面粗度

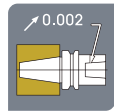

Run out accuracy
內孔偏擺度



Surface hardness
表面硬度

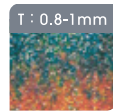

Carbonized depth
滲碳深度

| Order Code 訂購編號 | L | L1 | D1 | D2 | Fig 圖號 | Min ⁻¹ G2.5 動態平衡 | Spanner 扳手規格 | Recommended Torsion 推薦鎖固扭力 | Fixed Torque Spanner 固定扭力扳手 |
|--------------------|-----|-----|------|----|-----------|--------------------------------|-----------------|-------------------------------|--------------------------------|
| BT30-UC6-70 | 70 | 48 | 16 | 24 | 1 | 30,000 | M4 | 5Nm | 30294-5144 |
| UC6-90 | 90 | 68 | 16 | 29 | 1 | 30,000 | M4 | 5Nm | 30294-5144 |
| UC6-120 | 120 | 98 | 16 | 33 | 1 | 30,000 | M4 | 5Nm | 30294-5144 |
| BT40-UC6-90 | 90 | 63 | 16 | 27 | 1 | 30,000 | M4 | 5Nm | 30294-5144 |
| UC6-90T | 90 | 63 | 15.5 | 32 | 2 | 30,000 | M4 | 5Nm | 30294-5144 |
| UC6-120 | 120 | 93 | 16 | 32 | 1 | 30,000 | M4 | 5Nm | 30294-5146 |
| UC6-150 | 150 | 123 | 16 | 38 | 1 | 30,000 | M4 | 5Nm | 30294-5146 |

- Collet chuck designed without nut and with inner-holding collet. This has strong rigidity and high stability.
- Torque wrench is recommended for chuck stability.
- Torque wrench must be ordered separately.
- The recommended torsion and correct torque wrench prevents deformation of the tool holder.

- 沒有螺帽的後拉式夾頭設計，鋼性強穩定性高。
- 為求使用上的穩定性，建議使用扭力扳手。
- 扭力扳手必須另外訂購。
- 鎖固扭力不要超過推薦值的30%以上，過高的鎖固扭力，可能導致刀柄的變形。



UC GOLD CHUCK (UC10)

UC 黃金夾頭刀柄 (UC10)

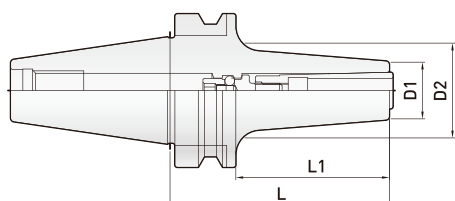
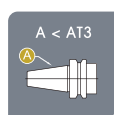

Fig 1 / 圖號 1



Fig 2 / 圖號 2



Taper tolerance
錐度公差

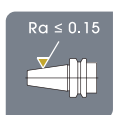

Surface roughness
表面粗度

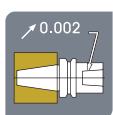

Run out accuracy
內孔偏擺度



Surface hardness
表面硬度

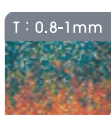

Carbonized depth
滲碳深度

Slim Long Type 小徑加長型

| Order Code 訂購編號 | L | L1 | D1 | D2 | Fig 圖號 | Min ⁻¹ G2.5 動態平衡 | Spanner 扳手規格 | Recommended Torsion 推薦鎖固扭力 | Fixed Torque Spanner 固定扭力扳手 |
|--------------------|-----|-----|----|----|-----------|--------------------------------|-----------------|-------------------------------|--------------------------------|
| BT30-UC10-70 | 70 | 48 | 24 | 32 | 1 | 30,000 | M5 | 7Nm | 30294-5152 |
| BT40-UC10-90 | 90 | 63 | 24 | 35 | 1 | 30,000 | M5 | 7Nm | 30294-5154 |
| UC10-120 | 120 | 93 | 24 | 40 | 1 | 30,000 | M5 | 7Nm | 30294-5156 |
| UC10-150 | 150 | 123 | 24 | 46 | 1 | 30,000 | M5 | 7Nm | 30294-5156 |
| BT50-UC10-110 | 110 | 72 | 24 | 36 | 1 | 20,000 | M5 | 7Nm | 30294-5156 |
| UC10-150 | 150 | 112 | 24 | 43 | 1 | 20,000 | M5 | 7Nm | 30294-5158 |
| UC10-200 | 200 | 162 | 24 | 52 | 1 | 20,000 | M5 | 7Nm | 30294-5159 |

High Vibration Damping Type 高阻尼減震型

| | | | | | | | | | |
|--------------|----|----|----|------|---|--------|----|-----|------------|
| BT40-UC10-70 | 70 | 38 | 30 | 37.5 | 2 | 30,000 | M5 | 7Nm | 30294-5152 |
|--------------|----|----|----|------|---|--------|----|-----|------------|

- Collet chuck designed without nut and with inner-holding collet. This has strong rigidity and high stability.
- Torque wrench is recommended for chuck stability.
- Torque wrench must be ordered separately.
- The recommended torsion and correct torque wrench prevents deformation of the tool holder.

- 沒有螺帽的後拉式夾頭設計，鋼性強穩定性高。
- 為求使用上的穩定性，建議使用扭力扳手。
- 扭力扳手必須另外訂購。
- 鎖固扭力不要超過推薦值的30%以上，過高的鎖固扭力，可能導致刀柄的變形。



UC GOLD CHUCK (UC16) High Vibration Damping Type

UC 黃金夾頭刀柄 (UC16) 高阻尼減震型

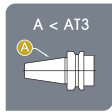
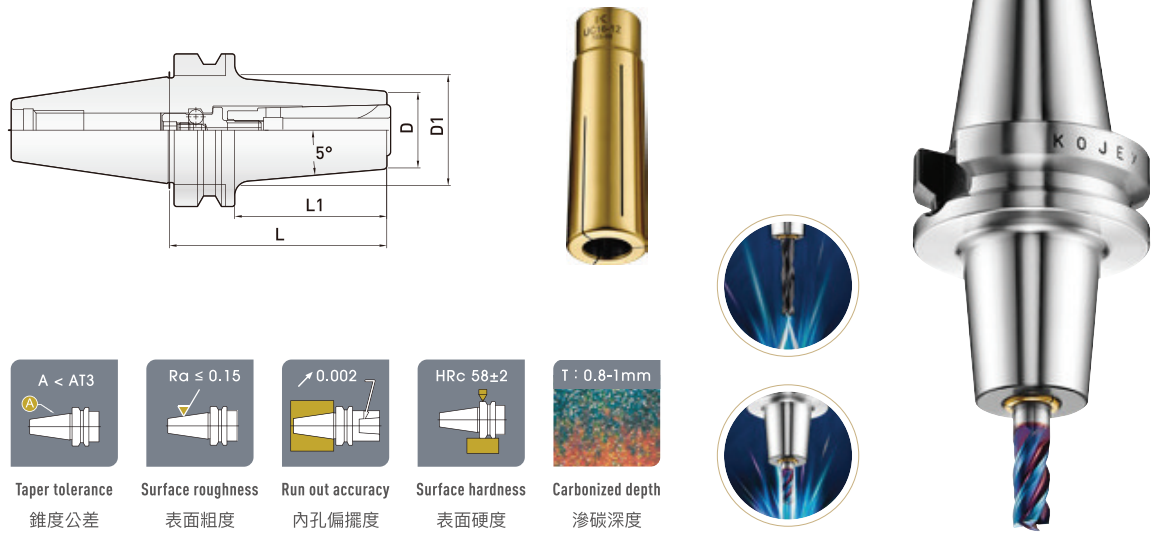

Taper tolerance
錐度公差



Surface roughness
表面粗度

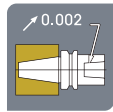

Run out accuracy
內孔偏擺度



Surface hardness
表面硬度

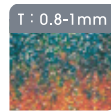

Carbonized depth
滲碳深度

| Order Code 訂購編號 | L | L1 | D | D1 | Min-1G2.5 動態平衡 | Spanner 扳手規格 | Recommended Torsion 推薦鎖固扭力 | Torque Wrench 扭力扳手 | Center Coolant 中心出水 | Side Coolant 側面出水 | Pin Collet Pin筒夾 |
|--------------------|-----|-----|----|----|-------------------|-----------------|-------------------------------|-----------------------|------------------------|----------------------|---------------------|
| BT30-UC16-70 | 70 | 48 | 32 | 40 | 30,000 | M6 | 15Nm | TW30+M06100 | ✓ | ✓ | X |
| BT40-UC16-70 | 70 | 43 | 40 | 47 | 30,000 | M6 | 15Nm | TW30+M06100 | ✓ | ✓ | X |
| UC16-90 | 90 | 63 | 32 | 40 | 30,000 | M6 | 15Nm | TW30+M06100 | ✓ | ✓ | X |
| UC16-120 | 120 | 93 | 32 | - | 30,000 | M6 | 15Nm | TW30+M06160 | ✓ | ✓ | X |
| BT50-UC16-120 | 120 | 78 | 32 | 42 | 20,000 | M6 | 15Nm | TW30+M06160 | ✓ | ✓ | X |
| UC16-150 | 150 | 108 | 32 | 52 | 20,000 | M6 | 15Nm | TW30+M06200 | ✓ | ✓ | X |

- Provide the center coolant and the side coolant.
- Select the side coolant must to use the collet with coolant slot, please check p.20
- Select the general collet for center coolant, please check p.19
- Coolant can be sprayed directly into the edge of tool for quick cooling and remove the steel chip.

- 可以選擇中心出水及側面出水的功能。
- 側面出水必須選用有水槽的夾頭，請參閱 p.20
- 中心出水選用一般的夾頭，請參閱 p.19
- 冷却液可直接噴到刀尖位置，可快速冷却及去除鐵屑。



UC GOLD CHUCK (UC20) High Vibration Damping Type

UC 黃金夾頭刀柄 (UC20) 高阻尼減震型

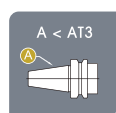
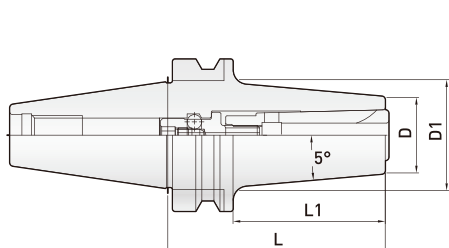

Taper tolerance
錐度公差

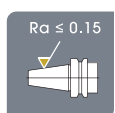

Surface roughness
表面粗度

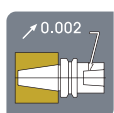

Run out accuracy
內孔偏擺度



Surface hardness
表面硬度

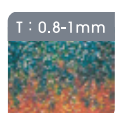

Carbonized depth
滲碳深度

| Order Code 訂購編號 | L | L1 | D | D1 | Min ⁻¹ G2.5 動態平衡 | Spanner 扳手規格 | Recommended Torsion 推薦鎖固扭力 | Torque Wrench 扭力扳手 | Center Coolant 中心出水 | Side Coolant 側面出水 | Pin Collet Pin筒夾 |
|--------------------|-----|-----|----|----|--------------------------------|-----------------|-------------------------------|-----------------------|------------------------|----------------------|---------------------|
| BT40-UC20-70 | 70 | 43 | 45 | - | 30,000 | M8 | 20Nm | TW30+M08100 | ✓ | ✓ | ✓ |
| BT50-UC20-100 | 100 | 62 | 45 | 58 | 20,000 | M8 | 20Nm | TW30+M08160 | ✓ | ✓ | ✓ |
| UC20-150 | 150 | 112 | 45 | 58 | 20,000 | M8 | 20Nm | TW30+M08160 | ✓ | ✓ | ✓ |

- Provide the center coolant and the side coolant.
- Select the side coolant must to use the collet with coolant slot, please check p.20
- Select the general collet for center coolant, please check p.19
- Select the PIN Collet, please check p.21
- Coolant can be sprayed directly into the edge of tool for quick cooling and remove the steel chip.

- 可以選擇中心出水及側面出水的功能。
- 側面出水必須選用有水槽的夾頭，請參閱 p.20
- 中心出水選用一般的夾頭，請參閱 p.19
- 可以選用PIN Collet，請參閱 p.21
- 冷却液可直接噴到刀尖位置，可快速冷却及去除鐵屑。



UC PIN COLLET CHUCK (UC25) High Vibration Damping Type

UC 安卡夾頭 (UC25) 高阻尼減震型

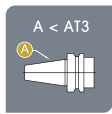
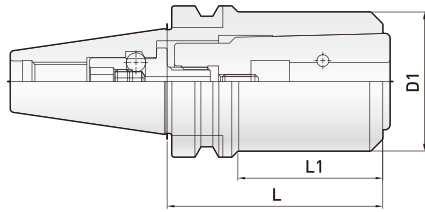

Taper tolerance
錐度公差



Surface roughness
表面粗度

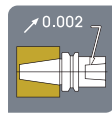

Run out accuracy
內孔偏擺度



Surface hardness
表面硬度

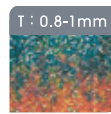

Carbonized depth
滲碳深度



| Order Code 訂購編號 | L | L1 | D1 | D2 | Min ¹ G2.5 動態平衡 | Spanner 扳手規格 | Recommended Torsion 推薦鎖固扭力 | Torque Wrench 扭力扳手 |
|--------------------|-----|-----|----|----|-------------------------------|-----------------|-------------------------------|-----------------------|
| BT40-UC25-90 | 90 | 63 | 58 | - | 30,000 | M10 | 25Nm | TW30+M10100 |
| BT50-UC25-100 | 100 | 62 | 58 | - | 20,000 | M10 | 25Nm | TW30+M10160 |
| UC25-150 | 150 | 112 | 58 | 72 | 20,000 | M10 | 25Nm | TW30+M10160 |

- The collet designed with PIN, 100% never tool pull out.
- Must be used R groove tool or standard specifications DIN 6535 HB for side lock tool.
- Must to choose the Pin collet, please check p.21

- 有PIN的夾頭設計，100%不掉刀。
- 必須使用R型溝槽刀具或標準規範DIN 6535 HB的側固刀具。
- 必須選用有PIN的筒夾，請參閱 p.21



— 側面出水 —
SIDE COOLANT



UC GOLD CHUCK (UC10) Slim Long Type

UC 黃金夾頭刀柄 (UC10) 小徑加長型

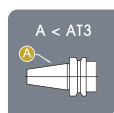
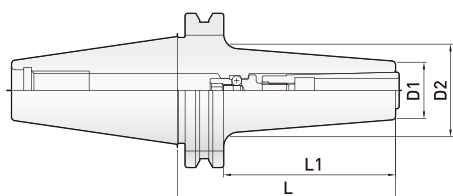

Taper tolerance
錐度公差

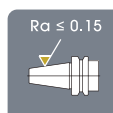

Surface roughness
表面粗度

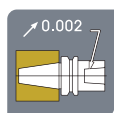

Run out accuracy
內孔偏擺度



Surface hardness
表面硬度

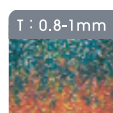

Carbonized depth
滲碳深度

| Order Code 訂購編號 | L | L1 | D1 | D2 | Min ⁻¹ G6.3 動態平衡 | Spanner 扳手規格 | Recommended Torsion 推薦鎖固扭力 | Fixed Torque Spanner 固定扭力扳手 |
|--------------------|-----|-----|----|----|--------------------------------|-----------------|-------------------------------|--------------------------------|
| SK40-UC10-90 | 90 | 71 | 24 | 36 | 20,000 | M5 | 7Nm | 30294-5154 |
| UC10-120 | 120 | 101 | 24 | 41 | 20,000 | M5 | 7Nm | 30294-5156 |
| UC10-150 | 150 | 131 | 24 | 47 | 20,000 | M5 | 7Nm | 30294-5156 |

- Collet chuck designed without nut and with inner-holding collet. This has strong rigidity and high stability.
- Torque wrench is recommended for chuck stability.
- Torque wrench must be ordered separately.
- The recommended torsion and correct torque wrench prevents deformation of the tool holder.

- 沒有螺帽的後拉式夾頭設計，鋼性強穩定性高。
- 為求使用上的穩定性，建議使用扭力扳手。
- 扭力扳手必須另外訂購。
- 鎖固扭力不要超過推薦值的30%以上，過高的鎖固扭力，可能導致刀柄的變形。



UC GOLD CHUCK (UC16) High Vibration Damping Type

UC 黃金夾頭刀柄 (UC16) 高阻尼減震型

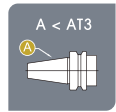
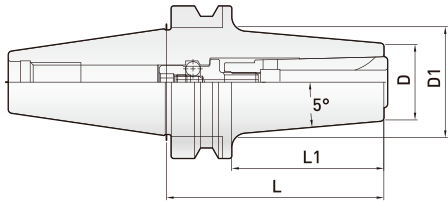

Taper tolerance
錐度公差



Surface roughness
表面粗度

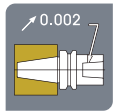

Run out accuracy
內孔偏擺度



Surface hardness
表面硬度

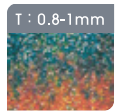

Carbonized depth
滲碳深度

| Order Code 訂購編號 | L | L1 | D | D1 | Min ⁻¹ G6.3 動態平衡 | Spanner 扳手規格 | Recommended Torsion 推薦鎖固扭力 | Torque Wrench 扭力扳手 | Center Coolant 中心出水 | Side Coolant 側面出水 | Pin Collet Pin筒夾 |
|--------------------|----|----|----|----|--------------------------------|-----------------|-------------------------------|-----------------------|------------------------|----------------------|---------------------|
| SK40-UC16-90 | 90 | 71 | 32 | 40 | 20,000 | M6 | 15Nm | TW30+M06100 | ✓ | ✓ | X |

- Provide the center coolant and the side coolant.
- Select the side coolant must use the collet with coolant slot, please check p.20
- Select the general collet for center coolant, please check p.19
- Coolant can be sprayed directly into the edge of tool for quick cooling and remove the steel chip.

- 可以選擇中心出水及側面出水的功能。
- 側面出水必須選用有水槽的夾頭，請參閱 p.20
- 中心出水選用一般的夾頭，請參閱 p.19
- 冷卻液可直接噴到刀尖位置，可快速冷卻及去除鐵屑。



UC GOLD CHUCK (UC20) High Vibration Damping Type

UC 黃金夾頭刀柄 (UC20) 高阻尼減震型

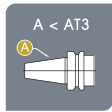
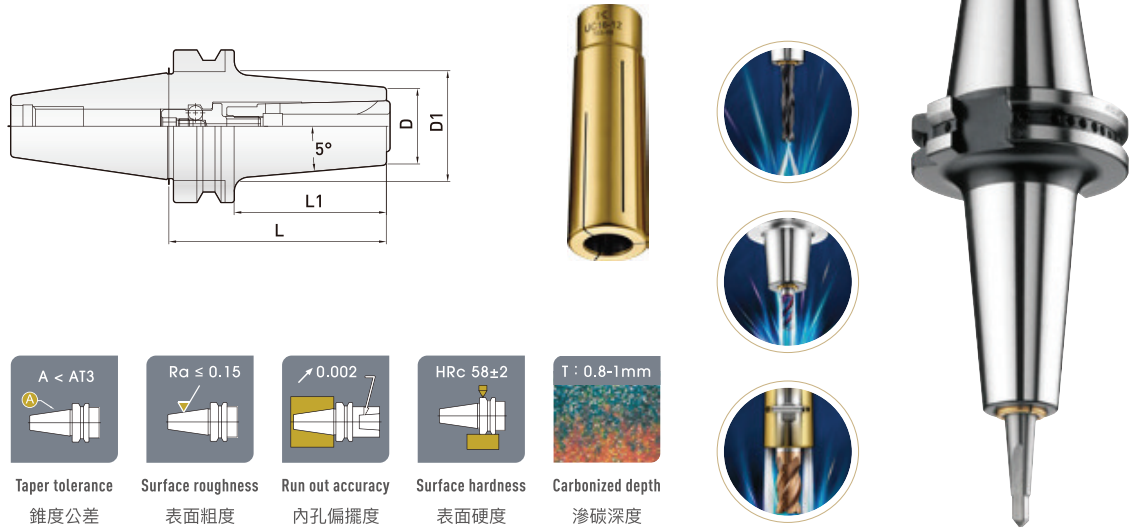

A < AT3

Taper tolerance
錐度公差



Ra ≤ 0.15

Surface roughness
表面粗度

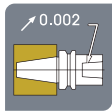

0.002

Run out accuracy
內孔偏擺度



HRC 58±2

Surface hardness
表面硬度

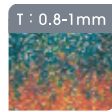

T : 0.8-1mm

Carbonized depth
滲碳深度

| Order Code 訂購編號 | L | L1 | D | D1 | Min ⁻¹ G6.3 動態平衡 | Spanner 扳手規格 | Recommended Torsion 推薦鎖固扭力 | Torque Wrench 扭力扳手 | Center Coolant 中心出水 | Side Coolant 側面出水 | Pin Collet Pin筒夾 |
|--------------------|----|----|----|----|--------------------------------|-----------------|-------------------------------|-----------------------|------------------------|----------------------|---------------------|
| SK40-UC20-70 | 70 | 43 | 45 | - | 20,000 | M8 | 20Nm | TW30+M08100 | ✓ | ✓ | ✓ |

- Provide the center coolant and the side coolant.
- Select the side coolant must use the collet with coolant slot, please check p.20
- Select the general collet for center coolant, please check p.19
- Select the PIN Collet, please check p.21
- Coolant can be sprayed directly into the edge of tool for quick cooling and remove the steel chip.

- 可以選擇中心出水及側面出水的功能。
- 側面出水必須選用有水槽的夾頭，請參閱 p.20
- 中心出水選用一般的夾頭，請參閱 p.19
- 可以選用PIN Collet，請參閱 p.21
- 冷却液可直接噴到刀尖位置，可快速冷却及去除鐵屑。



PIN COLLET COOLANT

— 安卡夾頭 —

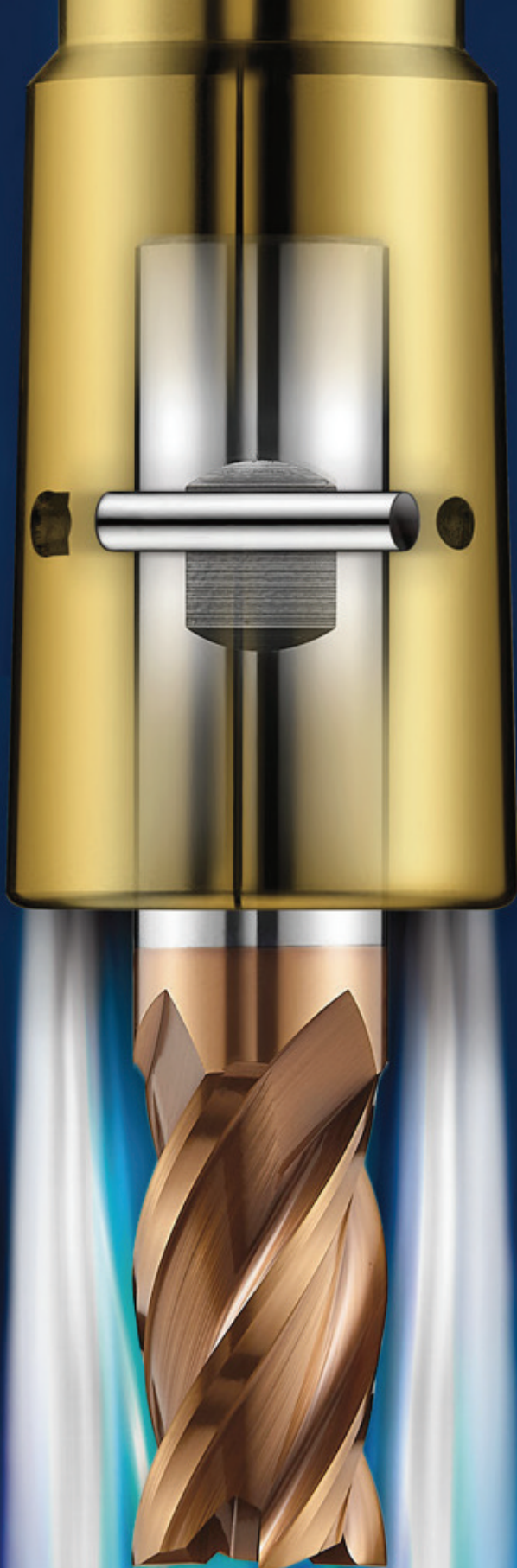

UC COLLET

UC 黃金夾頭

- Runout <math>< 5\mu\text{m}</math> (4×D)
- 跳動精度 <math>< 5\mu\text{m}</math> (4×D)

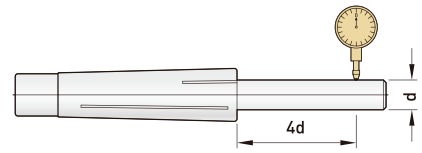

UC 6

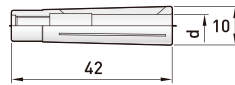

| Order Code 訂購編號 | (d) 夾持徑 |
|--------------------|------------|
| UC6-3 | 3 |
| 4 | 4 |
| 5 | 5 |
| 6 | 6 |



UC 10

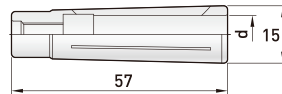

| Order Code 訂購編號 | (d) 夾持徑 |
|--------------------|------------|
| UC10-3 | 3 |
| 4 | 4 |
| 5 | 5 |
| 6 | 6 |
| 8 | 8 |
| 10 | 10 |



UC 16 Center Coolant (中心出水)

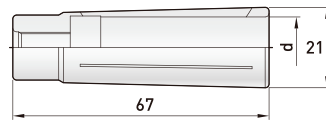

| Order Code 訂購編號 | (d) 夾持徑 |
|--------------------|------------|
| UC16-6 | 6 |
| 8 | 8 |
| 10 | 10 |
| 12 | 12 |
| 14 | 14 |
| 16 | 16 |



UC 20 Center Coolant (中心出水)

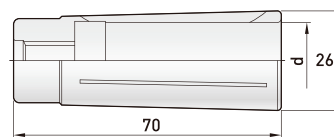

| Order Code 訂購編號 | (d) 夾持徑 |
|--------------------|------------|
| UC20-6 | 6 |
| 8 | 8 |
| 10 | 10 |
| 12 | 12 |
| 16 | 16 |
| 20 | 20 |

UC COLLET (Side Coolant)

UC 黃金夾頭 (側邊出水)

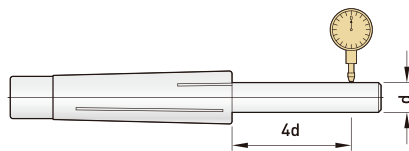

- Runout <math>< 5\mu\text{m}</math> ($4 \times D$)
- 跳動精度 <math>< 5\mu\text{m}</math> ($4 \times D$)

- Coolant can be sprayed directly into the edge of tool, for quick cooling and remove the steel chip.
- 冷却液可直接噴到刀尖位置，可快速冷却及去除鐵屑。

UC 16F / UC 20F

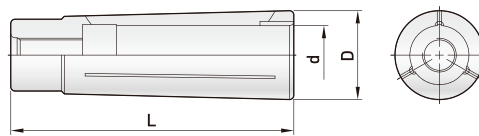

| Order Code 訂購編號 | (d) 夾持徑 | L | D |
|--------------------|------------|----|----|
| UC16- 6F | 6 | 67 | 21 |
| 8F | 8 | | |
| 10F | 10 | | |
| 12F | 12 | | |
| 14F | 14 | | |
| 16F | 16 | | |
| UC20- 6F | 6 | 70 | 26 |
| 8F | 8 | | |
| 10F | 10 | | |
| 12F | 12 | | |
| 16F | 16 | | |
| 20F | 20 | | |

UC PIN COLLET

UC 安卡夾頭

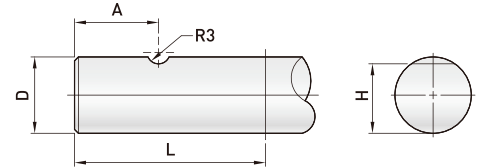
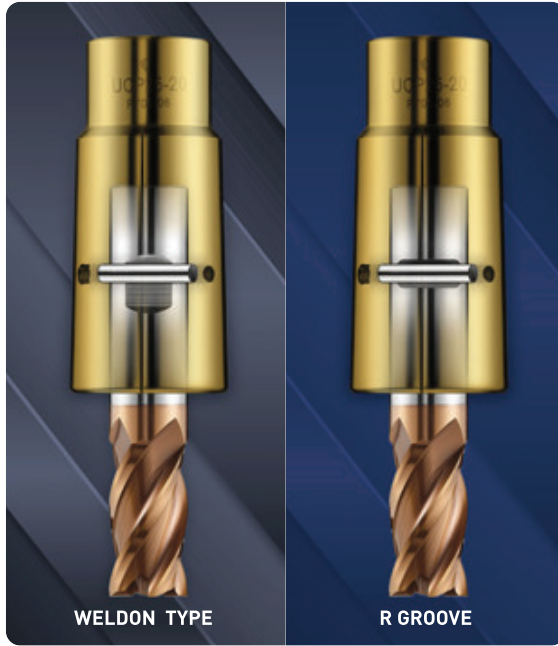

| Tool shark Dia. | | | | |
|-----------------|---------|---------|-----------------------------------|-------------------|
| D mm | L mm | A mm | H mm | R groove R 型溝槽 |
| 6 | 36 | 17 ± 2 | 4.8 ⁰ _{-0.4} | R3 |
| 8 | 40 | 17 ± 2 | 6.6 ⁰ _{-0.4} | |
| 10 | 40 | 19 ± 2 | 8.4 ⁰ _{-0.4} | |
| 12 | 45 | 21 ± 2 | 10.4 ⁰ _{-0.4} | |
| 16 | 48 | 21 ± 2 | 14.2 ⁰ _{-0.4} | |
| 20 | 50 | 22 ± 2 | 18.2 ⁰ _{-0.4} | |
| 25 | 56 | 29 ± 2 | 23 ⁰ _{-0.4} | |

- Provide the Pin collet for UC20 and UC25. The tools can choose the standard side lock tool (DIN6535HB) or grinded the R groove at tools.
- UC PIN夾頭有UC20及UC25兩個系列可以選擇，刀具必須自行在柄部研磨R型溝槽或者選用標準側固的刀柄 (DIN6535HB)。

UC 20P / UC 25P

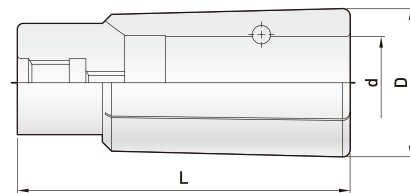

| Order Code 訂購編號 | (d) 夾持徑 | L | D |
|--------------------|------------|----|----|
| UC20- 6P | 6 | 70 | 26 |
| 8P | 8 | | |
| 10P | 10 | | |
| 12P | 12 | | |
| 16P | 16 | | |
| UC25- 12P | 12 | 90 | 40 |
| 16P | 16 | | |
| 20P | 20 | | |
| 25P | 25 | | |

FIXED TORQUE SPANNER

固定扭力扳手



| Order Code 訂購編號 | Torque 扭力值 | ⊙ | L | Tool Item 適用規格 |
|--------------------|---------------|---|-----|-------------------|
| 30294-5144 | 5Nm | 4 | 70 | UC6 |
| 5146 | 5Nm | 4 | 115 | |
| 5152 | 7Nm | 5 | 55 | UC10 |
| 5154 | 7Nm | 5 | 90 | |
| 5156 | 7Nm | 5 | 140 | |
| 5158 | 7Nm | 5 | 180 | |
| 5159 | 7Nm | 5 | 240 | |

TORQUE WRENCH

扭力扳手



| Order Code 訂購編號 | Torque Nm 扭力值 | Square Drive 接頭 | Length (mm) 長度 |
|--------------------|------------------|--------------------|-------------------|
| TW30 | 5-30 | 3 / 8" | 300 |



| Order Code 訂購編號 | ⊙ | Length (mm) | Tool Item 適用規格 |
|--------------------|----|-------------|-------------------|
| M06100 | 6 | 100 | UC16 |
| M06160 | 6 | 160 | UC16 |
| M06200 | 6 | 200 | UC16 |
| M08100 | 8 | 100 | UC20 |
| M08160 | 8 | 160 | UC20 |
| M10100 | 10 | 100 | UC25 |
| M10160 | 10 | 160 | UC25 |