

# CLF5H

## 連桿油壓缸 (眼鏡蛇缸)

## CLF5H HYDRAULIC LEVERAGE CLAMP



### 產品特性

此系列產品設計中採用連桿機構,在解除夾持狀態時,壓臂可拉到低於夾持面的位置,減少對工件裝卸的干涉,因此操作方便,缸體採用一體成型。  
產品動作軌跡非常小,用傳統的轉角缸/缸桿缸都難以夾持到的部位均可以達到夾持作用,並可以減少對周圍機器設備的干擾,達到節省工作空間的目的。產品採用了專用防塵設計,防止了切削及冷卻液的滲入,實現了高密封性,因此在比較惡劣的環境下也能使用。

最大操作壓力: 70 kgf/cm<sup>2</sup>  
最小操作壓力: 10 kgf/cm<sup>2</sup>

### FEATURES

Operate conveniently, this series products design with connecting rod structure, at the time of termination holding state, clamping arm can be put lower than holding position, and reduce the interference with loading and unloading operation. Clamping arm of the products is very flexible. It can hold more capacity than swing clamp and leverage clamp, and can reduce the interference of the surrounding equipment, so it can save working space. Product with special dust proof design and high sealing, can prevent the cutting chips and coolant to infiltration. So it can be used in more severe conditions.

Max. operating pressure: 70 kgf/cm<sup>2</sup>  
Min. operating pressure: 10 kgf/cm<sup>2</sup>

### 剖面圖 Sectional view

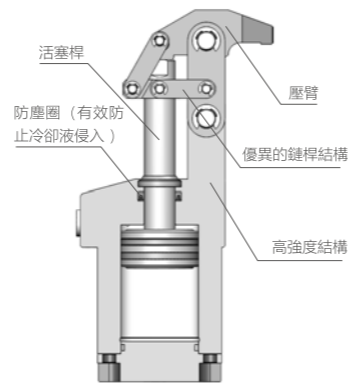

### 注意事項

夾緊及放鬆動作速度需適當放緩。

### NOTE

The acting speed of clamping-unclamping should be slowed down.

### 訂購標示法 ORDERING INDICATION

示例: CLF5H - 32G

CLF5H	系列 Series	CLF5H
32	油缸內徑 Hydraulic cylinder inside diameter	Φ 25, Φ 32, Φ 40, Φ 50
G	油口型式 Port type	空白: 配管式 G: 油路板式



LINE TYPE  
配管式



G-MANIFOLD TYPE  
G:油路板式

### LINE TYPE 配管式

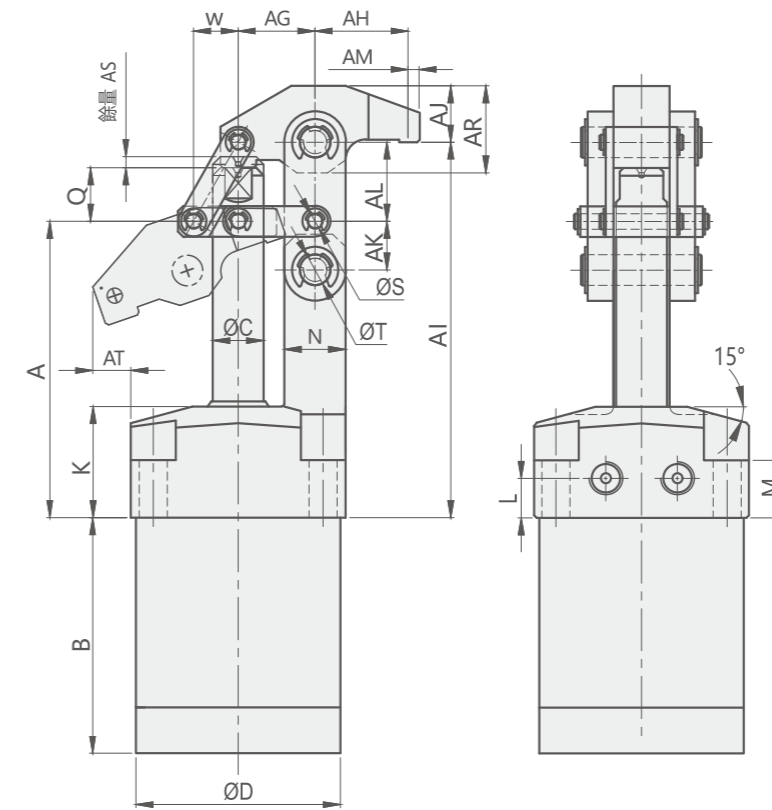
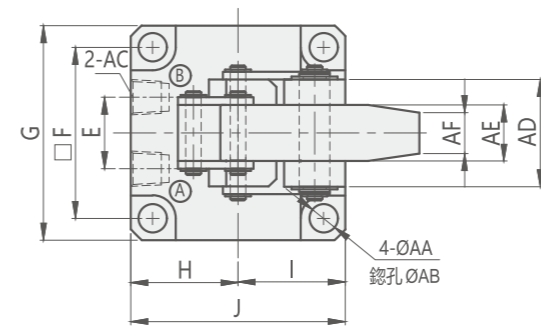

- Ⓐ 夾持油孔 Clamping port
- Ⓑ 放鬆油孔 Unclamping port

Unit:mm

MODEL ITEM	CLF5H-25	CLF5H-32	CLF5H-40	CLF5H-50
A	70	75	89.5	101.5
B	59.5	70.5	79.5	86.5
C	14	14	16	20
D	47	55	65	80
E	21	21	25	28
F	40	47	55	67
G	50	59	69	84
H	25	29.5	34.5	42
I	25	29.5	34.5	42
J	50	59	69	84
K	30.5	30.5	37.5	43.5
L	11.5	11.5	13.5	15.5
M	13.5	15.5	20.5	22.5
N	12	16	20	24
Q	12	14	20	21
S	5	5	6	6
T	6	8	10	12
U	56.5	60	72	83
W	13	13	16	17.5
AA	5.5	6.6	9	11
AB	9.5	11	14	18
AC	PT1/8	PT1/8	PT1/4	PT1/4
AD	22	28	36	42
AE	12	16	19	22
AF	8	12	14	16
AG	19	21.5	24.5	30
AH	23	28	31	37
AI	88	95	117.5	132.5
AJ	13	15	18	22
AK	13.5	15	17.5	19
AL	18	20	28	31
AM	4	4	4	4
AR	20	23	28	34
AT	12	11	18	15

### 規格參數表 SPECIFICATION

型號	理論夾持力 (70 kgf/cm <sup>2</sup> )	夾緊行程	總行程	推出容積	拉入容積	推出受壓面積	拉入受壓面積	使用溫度範圍	使用液體
MODEL	CLAMPING FORCE AT 70 kgf/cm <sup>2</sup> (kgf)	CLAMPING STROKE (mm)	TOTAL STROKE(mm)	CYLINDER CAPACITY CLAMP(cm <sup>3</sup> )	CYLINDER CAPACITY UNCLAMP(cm <sup>3</sup> )	EFF.PISTON AREA CLAMP(cm <sup>2</sup> )	EFF.PISTON AREA UNCLAMP(cm <sup>2</sup> )	RANGE OF TEMPERATURE(°C)	USABLE FLUID
CLF5H-25	290	31.5	34	16.69	11.46	4.91	3.37	-10~+70°C	相當於ISO黏度等級的ISO-VG-32一般液壓油 General Hydraulic Oil Equivalent to ISO-VG-32
CLF5H-32	441	35.5	38	30.55	25.08	8.04	6.60	-10~+70°C	
CLF5H-40	709	41	44	55.26	46.46	12.56	10.56	-10~+70°C	
CLF5H-50	1136	47	50	98.15	82.45	19.63	16.49	-10~+70°C	



**G: MANIFOLD TYPE G油路板型**

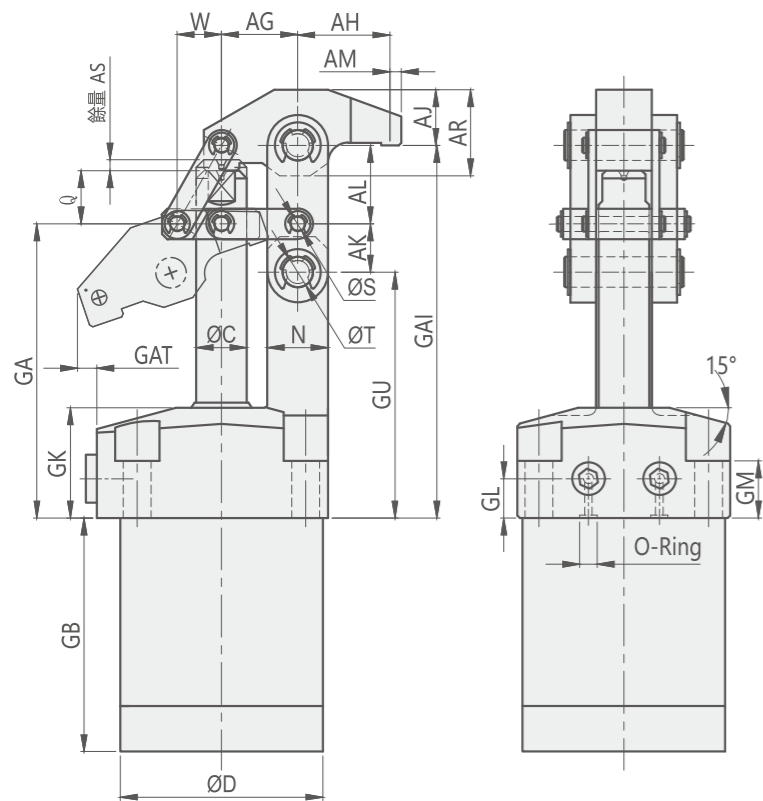
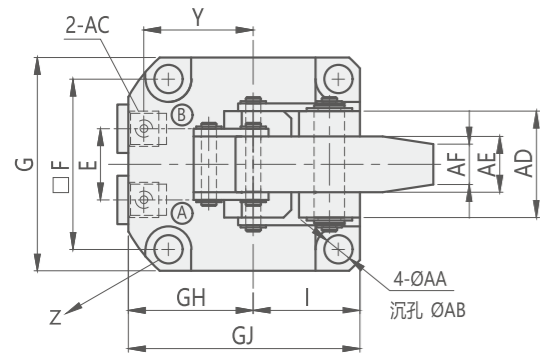

- Ⓐ 夾持油孔 Clamping port
- Ⓑ 放鬆油孔 Unclamping port

Unit:mm

MODEL ITEM	CLF5H-25G	CLF5H-32G	CLF5H-40G	CLF5H-50G
GA	70.5	75.5	90	102
GB	59	70	79	86
C	14	14	16	20
D	47	55	65	80
E	21	21	25	28
F	40	47	55	67
G	50	59	69	84
GH	35	37.5	45.5	51
I	25	29.5	34.5	42
GJ	60	67	80	93
GK	31	31	38	44
GL	12	12	14	16
GM	18	17	21	23
N	12	16	20	24
Q	12	14	20	21
S	4	5	6	6
T	6	8	10	12
GU	57	60.5	72.5	83
W	13	13	16	17.5
O型圈 O-Ring	S4	S4	S4	P5
Y	29	32	37	44
Z	R39	R43	R51	R57
AA	5.5	6.6	9	11
AB	9.5	11	14	18
AC	G1/8	G1/8	G1/4	G1/4
AD	22	28	36	42
AE	12	16	19	22
AF	8	12	14	16
AG	19	21.5	24.5	30
AH	23	28	31	37
GAI	88.5	95.5	118	133
AJ	13	15	18	22
AK	13.5	15	17.5	19
AL	18	20	28	31
AM	4	4	4	4
AR	20	23	28	34
GAT	2	3	7	6

