

## SMART-III Series

Multi-function CNC Surface Grinders

Accurate. Consistent. Affordable.

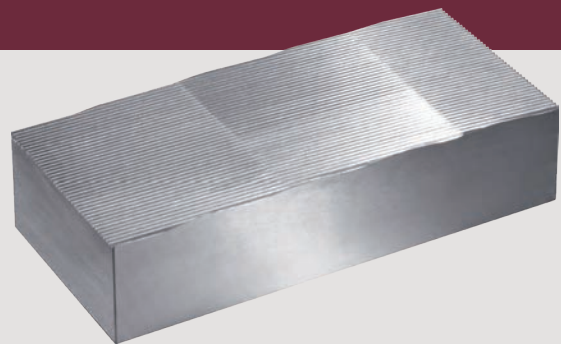

**CHEVALIER**<sup>®</sup>  
Grinding / Turning / Milling

We shape your ideas.™



3 axis speeds are controlled by AC servo motor for any complicated shape and finer finishes.

## Accurate. Consistent. Affordable.

These words describe the driving forces behind the design of our SMART-III CNC surface grinding machines. They're the standards required by the medical, automotive, mining, semiconductor, aerospace, injection mold making and job shop industries in order to meet current and future market needs and pave the way to factory automation.

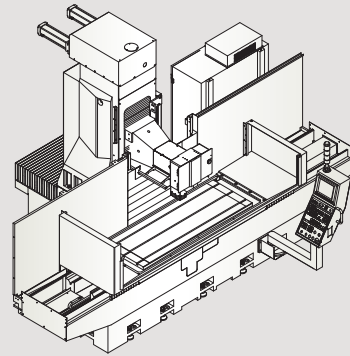

This series is capable of producing complicated shapes for highly accurate workpieces along with finer finishes. The heavy-duty slide rails, one-piece base casting and hardened wheelhead guideways create a solid, rigid machine structure that minimizes vibration, movement and displacement.

Chevalier's user-friendly grinding machines include our exclusive PC-based SMART iControl featuring conversational programming. Combined with TaskLink, it allows operators to create their own programs for generating complex grinding tasks in a single cycle—without an engineering degree.



The SMART-B1224III is shown with optional accessories.

# Key Features and Benefits

## Optimized structure

Chevalier's R&D team designed the SMART-III with precision structure analysis, counterweight balance system and double "V" design guideways for enhanced rigidity, increased stability and high-accuracy grinding efficiency. (SMART-H/B818III / SMART-H/B24III)

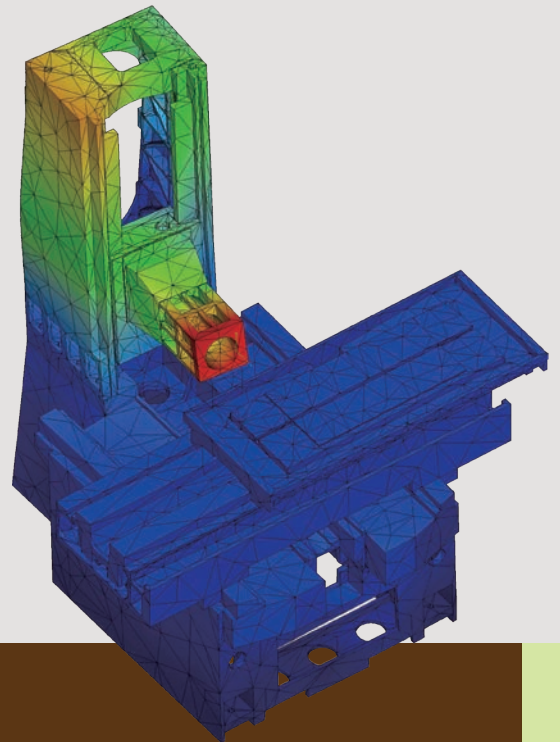

## Optional fully enclosed cover design

The fully enclosed cover design provides more protection, preventing cutting coolant splashing and oil mist dissipation. It completely protects the operator, avoiding grinding danger.

A higher level of computing, data analysis and HMI to improve your production process



The iMachine Communications System™ collects and integrates data from different machine controllers\* and monitors the tasks and processes remotely. That means you will save physical time being in front of machines, reduce production time by monitoring on one device and foresee the wear and tear with live data.

*\*Controllers vary depending on regions and may be subject to change without notice or obligation.*



## iMachine Communications System™ (iMCS)

iMCS is a comprehensive remote monitoring software that integrates with IoT functions on Chevalier's CNC machines to perform 24/7 data collection, utilization monitoring, data analysis, alarm history, maintenance and overall equipment effectiveness (OEE), all which help to avoid downtime and increases productivity. Additional PC and software are required.



# Control Features and Benefits

## All new SMART iControl

The SMART iControl's powerful computing force enhances the HMI (Human Machine Interface) for greater precision. Combining the SMART iControl with data analysis from network connectivity allows managers to improve the production process and increase output.

## The SMART iControl's conversational programming eliminates complicated programming codes

The SMART iControl supports M3 serial communication servo systems, a communication bandwidth increased to 100Mbps and support for 24-bit resolution, to improve reading speed and processing smoothness.

High computing capabilities of 2,000 single blocks per second produce high-precision smoothness, high-precision contour control, machining path smoothing, multi-group working conditions and quick parameter setting to significantly improve the grinding machine's accuracy and flatness.

Up to six CNC axes can be controlled for multi-function machining requirements. A single axis group can connect up to four axes or four/five axes for complex forming machining.

The SRI interface external communication IO module adds extra IO points (optional) and connects other automation equipment to meet future automation needs.

The SMART iControl comes standard with a 10.4" LCD high color monitor with HMI.

The three-dimensional graphic image display minimizes text descriptions and looks very similar to the actual workpieces.

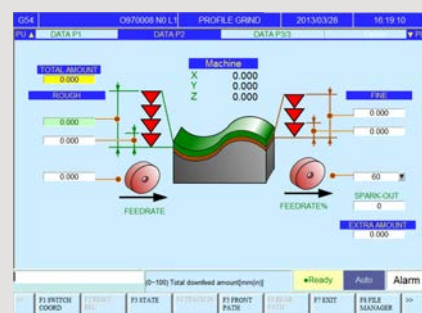
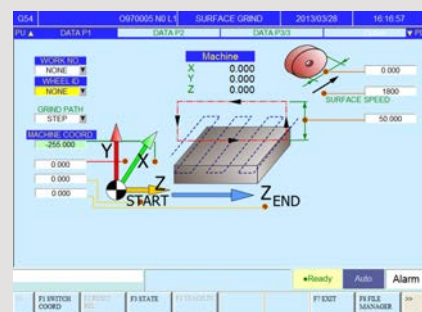
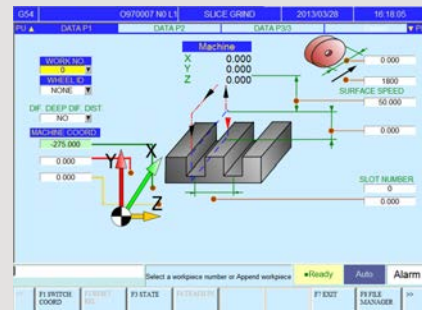
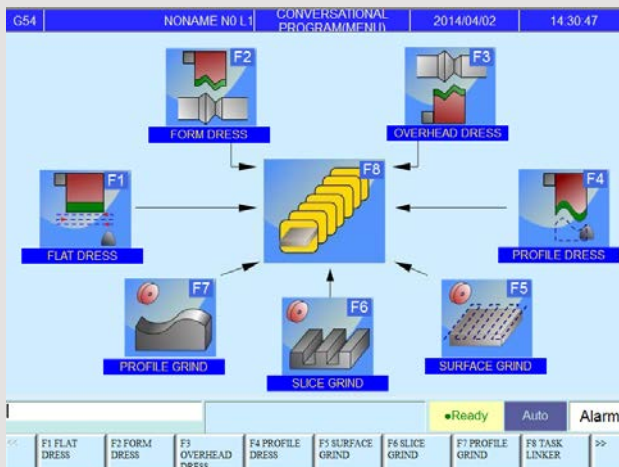



SMART iControl

054 0970002 NO L1 PROFILE GRIND 20120810 17:57:02

Machine  
 X: -10.2536  
 Y: -1.0320  
 Z: -6.6231

Graphical interface showing a 3D model of a part with various control parameters and buttons.

CHEVALIER

SINGLE LOAD

Function keypad with letters A-Z, numbers 0-9, and special keys like HOME, END, and ENTER.

X<sub>0</sub> Y<sub>0</sub> Z<sub>0</sub> 4<sub>0</sub> 4<sub>1</sub> 4<sub>2</sub> 4<sub>3</sub> 4<sub>4</sub> 4<sub>5</sub> 4<sub>6</sub> 4<sub>7</sub> 4<sub>8</sub> 4<sub>9</sub>

PARK PARK LEFT RIGHT

CYCLE

Special function keypad with buttons for COPY, PASTE, and other machine-specific functions.

FEEDRATE OVERRIDE

Rotary dial with scale from 0 to 150.

SPINDLE OVERRIDE

Rotary dial with scale from 50 to 120.

POWER

RETRACT

EMERGENCY STOP

Handheld control device with 'FEEDRATE' and 'EMERGENCY STOP' buttons.

# Auto Grinding Modes

The SMART iControl has three types of graphic conversational grinding modes.

Additionally, our new TaskLink mode enables operators to complete complex grinding tasks in one cycle.

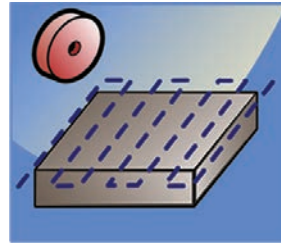

Surface Grinding

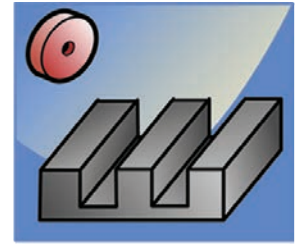

Slice Grinding

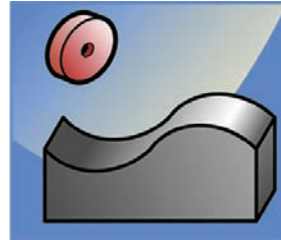

Profile Grinding

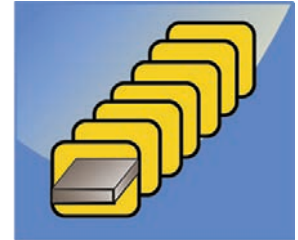

TaskLink

# Wheel Dressing

## Constant contact dressing mode

A normal dressing mode wastes time by cutting in air. The SMART iControl dressing mode never cuts air because the diamond is in constant contact with the wheel to minimize dress time.

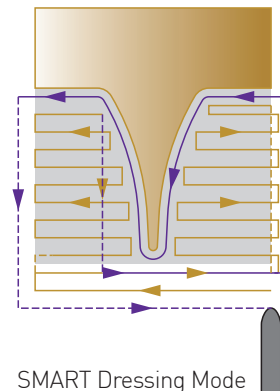

SMART Dressing Mode

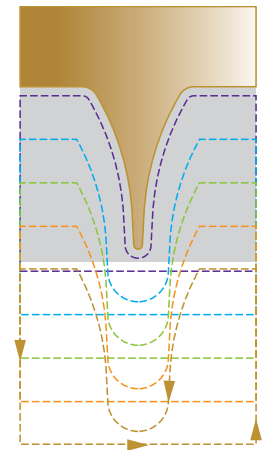

Normal Dressing Mode

## Auto dressing modes

Conversational graphic automatic wheel dressing modes can be linked with any—or all—grinding modes.

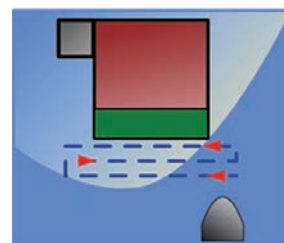

Table Type Single Tip Dresser

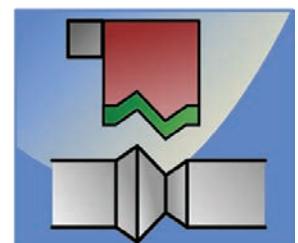
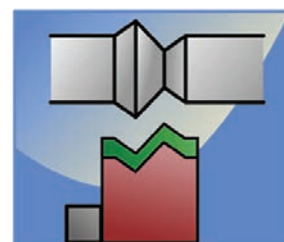
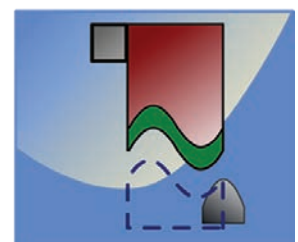

Table Type Diamond Roller



Over the Head Diamond Roller



Profile Dressing



## Applications

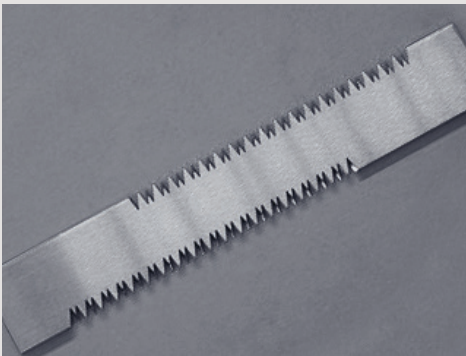
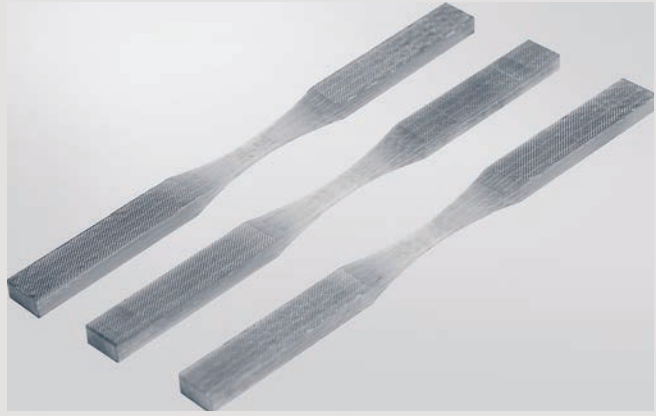
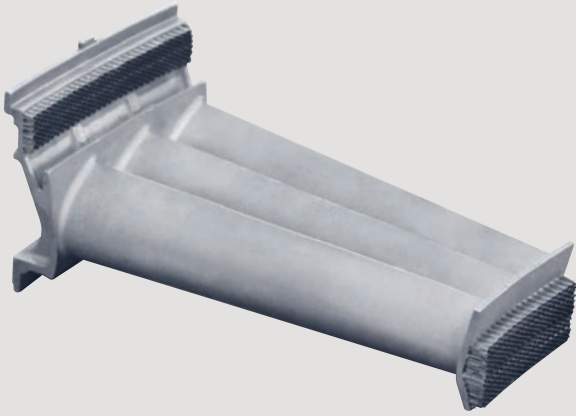

The SMART-III easily adapts to future needs for job shops, medical, automotive, semiconductor and aerospace

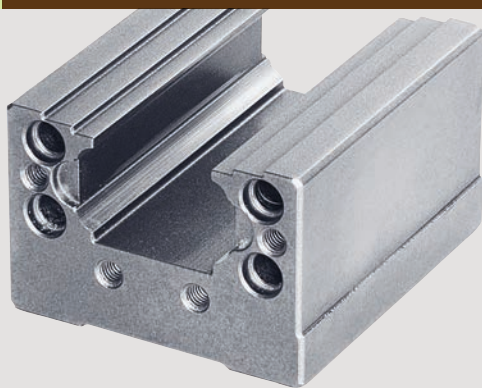

# Machine Construction SMART-H/B818III

## Spindle design

The spindle is supported by four Class 7 (P4) super-precision, angular-contact ball bearings and directly coupled with a low-vibration, Class V3 spindle motor. An air-purged spindle is available upon request.



The SMART-B818III is shown with optional accessories.

## Elevating transmission mechanism

The wheelhead elevation accuracy is designed with a counterweight balance system to ensure micro down feed accuracy.

Precision angular contact ball bearings run through a matching sleeve, which is preloaded between the linear guideways to ensure accurate and precise positioning with stick-slip free movement.



The double "V" guideways for table and saddle aids in precision side grinding operations

## Hydraulic table speed control

The table longitudinal speed can be adjusted independently by turning the two knobs either right or left. (SMART-H type)

SMART-H type model features independent, adjustable, table speed control knobs.



## Double "V" guideways for table and saddle

The hand-scraped, Turcite-B longitudinal guideways between table and saddle feature a double "V" design, which is ideal for side grinding operations.

- SMART-H type grinders (2-axis CNC control), with hydraulic cylinder longitudinal movement.
- SMART-B type grinders (3-axis CNC control), with ballscrew longitudinal movement.



Longitudinal double "V" guideways



Cross feed double "V" guideways

# Machine Construction

## SMART-H/B1224III / SMART-H/B1640III

### Spindle design

The spindle is supported by four Class 7 (P4), super-precision, angular-contact ball bearings that are permanently lubricated. The new spindle design includes circulation grooves for air cooling.



The SMART-H1224III is shown with optional accessories.

A hardened and ground table guideway system with precision-needle roller bearings provides stick-slip-free movement when cutting or in rapid traverse

### SMART-H type grinders, 2-axis CNC control

The SMART-H type grinders use hydraulics to travel from 5~25 m/min (16~82 fpm).

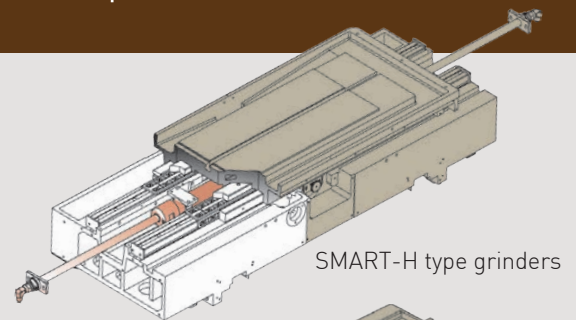

SMART-H type grinders

### SMART-B type grinders, 3-axis CNC control

The X-axis for SMART-B type grinders utilizes servo driven ballscrews for precise positioning and can achieve a speed of 0~20 m/min (0~65.6 fpm).

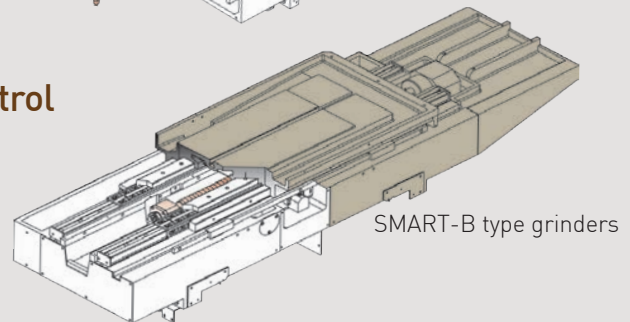

SMART-B type grinders



The SMART-B1640III is shown with optional accessories.

# Machine Construction

## SMART-H/B2440III / SMART-H/B 2460III / SMART-H/B2480III

### High-precision heavy-duty spindle design

This series uses a large-diameter, cartridge-type spindle that is air-cooled and precisely balanced with a spindle motor that is totally enclosed. Six pieces of Class 7 (P4) permanently lubricated, angular-contact ball bearings provide maximum spindle support. The spindle design ensures an extremely smooth surface finish and consistent accuracy.



The SMART-B2460III is shown with optional accessories.

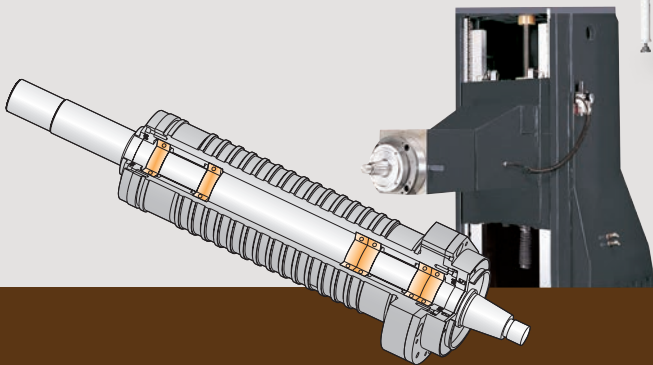

## SMART-24III Series spindle design ensures extremely smooth surface finish and consistent accuracy

### Column

The column is made of dense, high-grade, stress-relieved cast iron. The computer-aided design features a ribbed, honeycombed structure that resists flexing and vibration during heavy-duty machining. The spindle travels on hardened and grounded square ways.

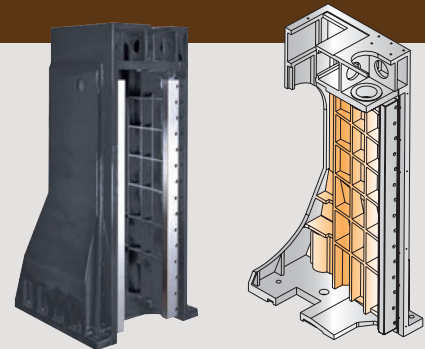

### Smooth and accurate wheelhead movement

The wheelhead is positioned with a C3-grade ballscrew driven by a servo motor. The wheelhead guideways are laminated with Turcite-B, anti-friction materials and then precisely hand scraped. The down-feed accuracy can be 0.002 mm (0.00008").

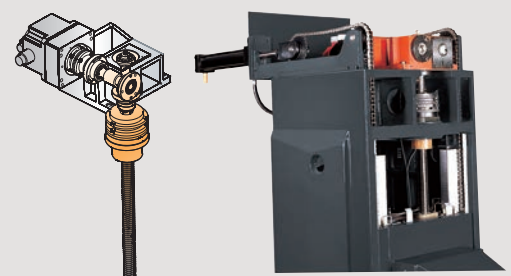

### Spindle head counterweight balance system

Pneumatic counterweights are installed in the spindle to eliminate backlash and prevent premature wearing of the elevating screws.

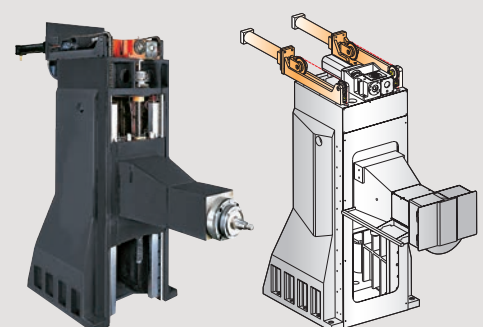

## Stable feed, superior accuracy

The crossfeed slideway system features a perfect mating of linear slideways, precision ballscrews and a servo motor that provides high torque, speed and accurate positioning with a minimum increment of 0.001 mm (0.0001").

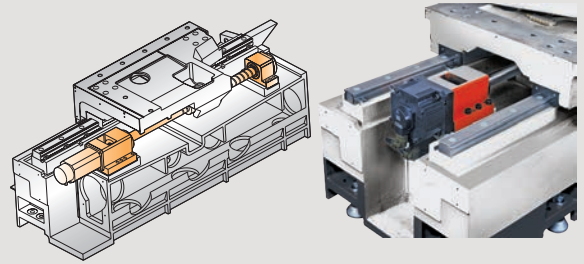

## Longitudinal slideways

The longitudinal slideways feature a double "V" configuration instead of the usual flat "V" design. The double "V" design improves the structural rigidity and stability of the front base. With Turcite-B, anti-friction material lamination of the slideways, smooth, stable travel is consistently maintained during all kinds of machining conditions.

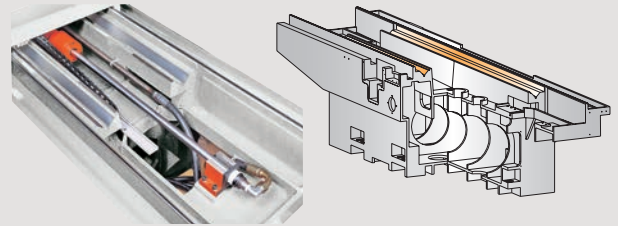

## Longitudinal ballscrew drive construction (SMART-B type)

The table is driven by an AC servo motor and positioned with a high precision ballscrew, maximizing the control of table speed and position.

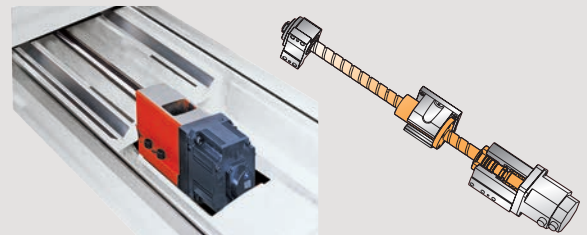

## Automatic wheel dressing with compensation

An automatic wheel dressing with compensation feature dresses the wheel automatically during rough and/or fine grinding and again at the end of rough grinding. This enables the machine to run unattended for hours, making it ideal for high-volume production runs, while reducing machining costs and increasing line productivity.

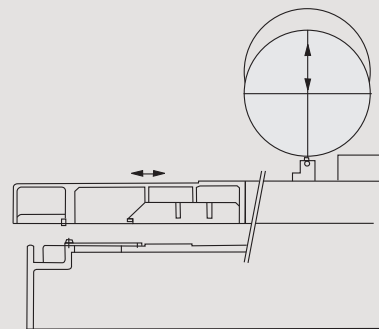

## Automatic lubrication system

An automatic lubrication system is standard on all machines. The system uses a sensor to monitor lubrication pressure. The machine alerts with a warning message automatically when the pressure drops below a preset level.

- |                        |                        |
|------------------------|------------------------|
| 1. Elevating leadscrew | 4. Crossfeed ballscrew |
| 2. Column slideways    | 5. Flow divider        |
| 3. Table guideways     | 6. Lubricator          |

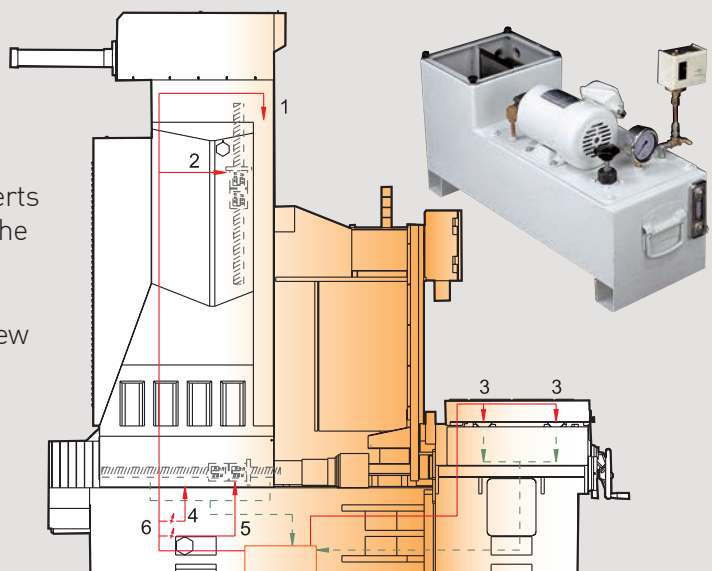

# Max. Working Space

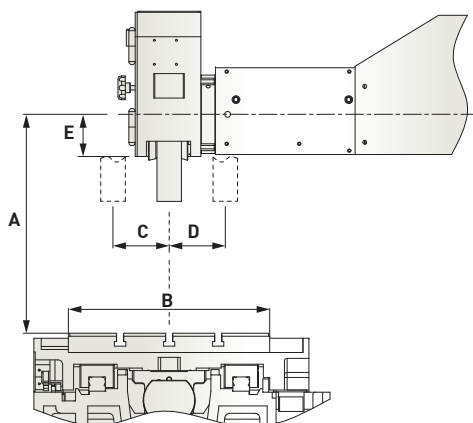

# Table and T-slot Dimensions

Units: mm (")

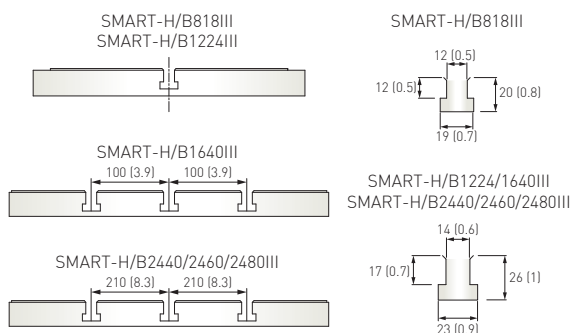

Units: mm (")

Item	A	B	C	D	E
SMART-H818III	445 (17.5)	200 (7.9)	110 (4.3)	110 (4.3)	57 (2.2)
SMART-B818III	395 (15.6)	200 (7.9)	110 (4.3)	110 (4.3)	57 (2.2)
SMART-H/B1224III	600 (23.6)	300 (11.9)	167.5 (6.6)	182.5 (7.2)	86 (3.4)
SMART-H/B1640III	600 (23.6)	400 (15.7)	222.5 (8.8)	227.5 (9.0)	86 (3.4)
SMART-H/B2440III	850 (33.5)	600 (23.6)	325 (12.8)	325 (12.8)	105 (4.1)
SMART-H/B2460III	850 (33.5)	600 (23.6)	325 (12.8)	325 (12.8)	105 (4.1)
SMART-H/B2480III	850 (33.5)	600 (23.6)	325 (12.8)	325 (12.8)	105 (4.1)

SMART-H/B818III	T-slot x 1
SMART-H/B1224III	T-slot x 1
SMART-H/B1640III	T-slot x 3
SMART-H/B2440III	T-slot x 3
SMART-H/B2460III	T-slot x 3
SMART-H/B2480III	T-slot x 3

# Machine Dimensions SMART-H/B818III

Units: mm (")

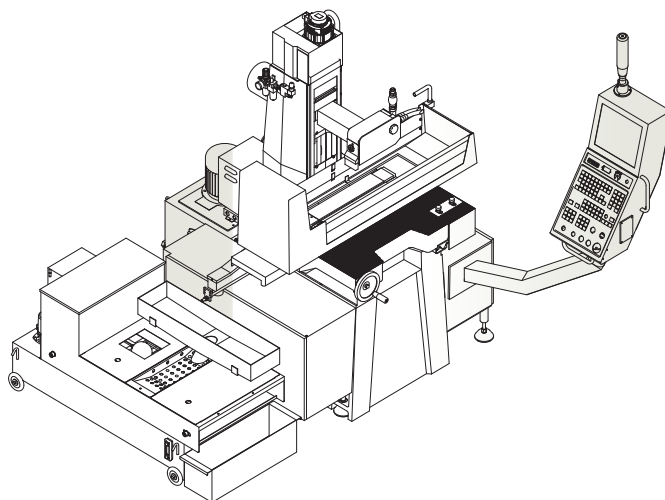
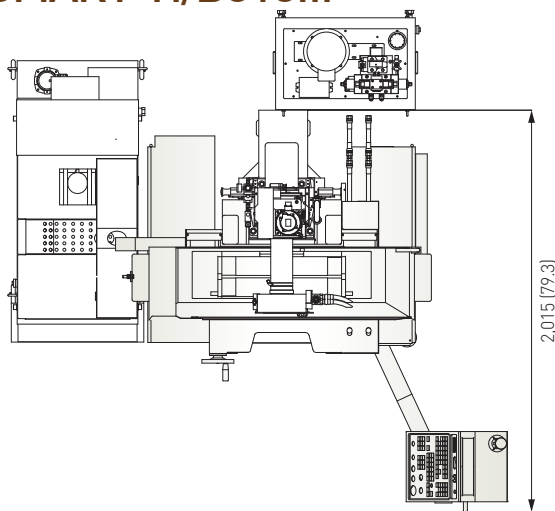

Note: Machine shown with optional accessories.

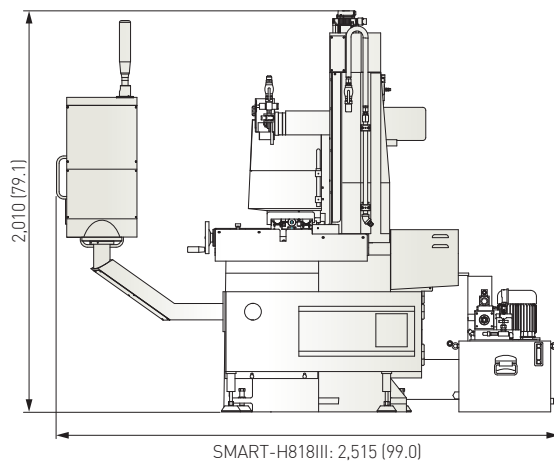
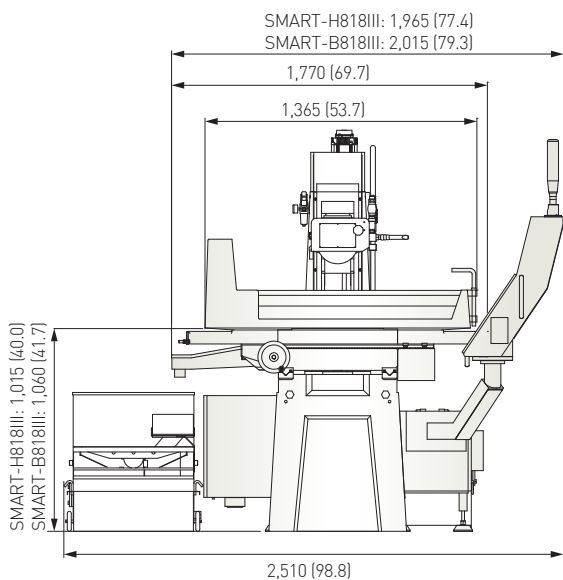

# Machine Dimensions

## SMART-H/B1224III / SMART-H/B1640III

Units: mm (")

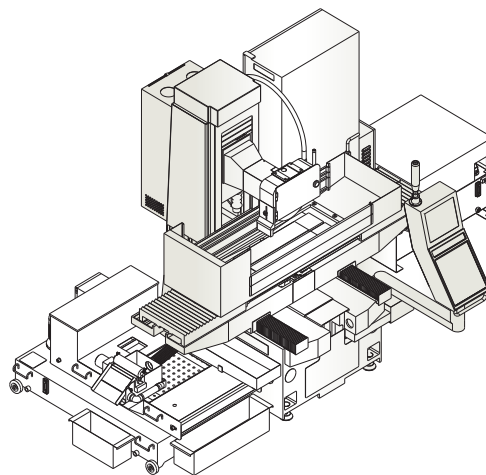
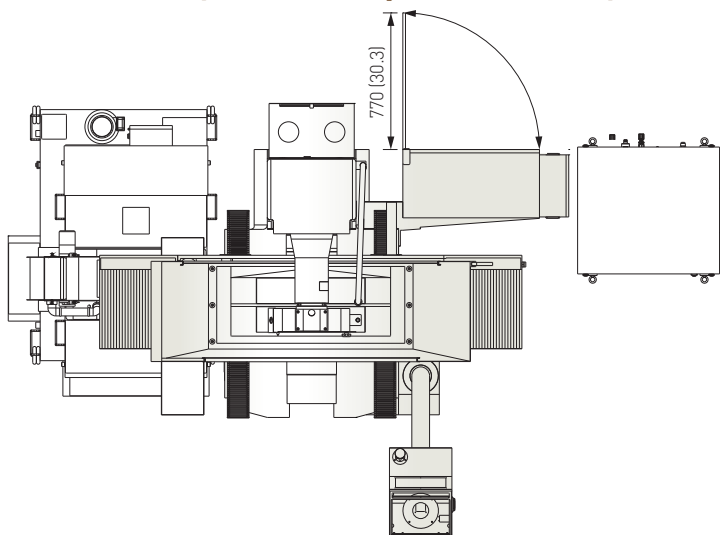

Note: Machine shown with optional accessories.

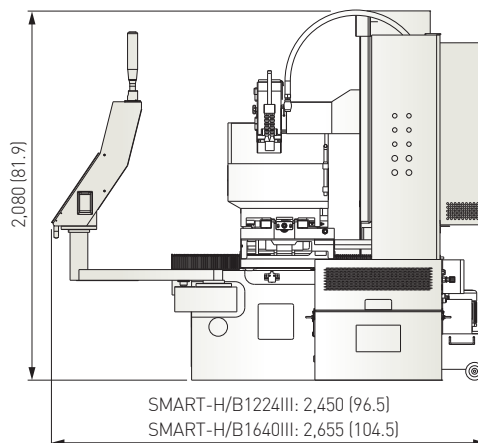
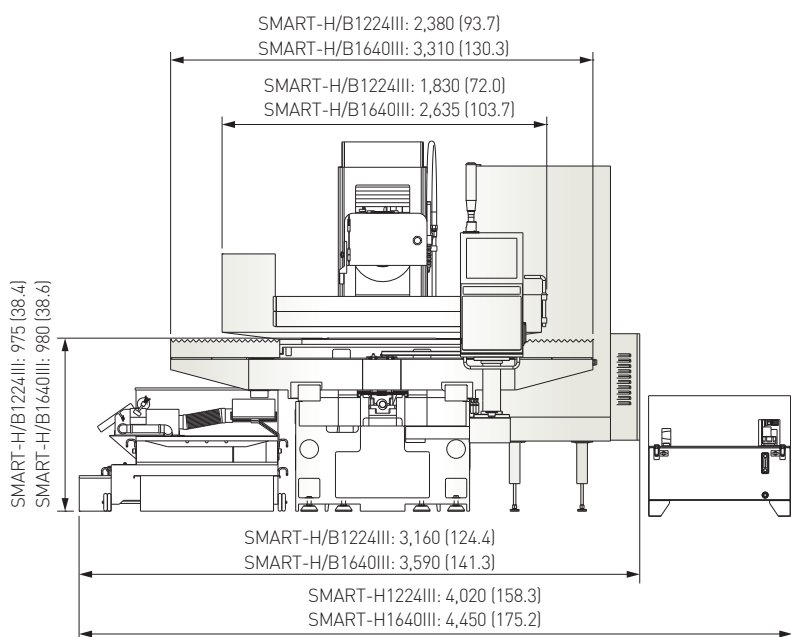

## Loading Capacity

Item	SMART-H/B818III	SMART-H/B1224III	SMART-H/B1640III
A	175 kg (385 lbs.)	264 kg (577 lbs.)	133 kg (287 lbs.)
B	35 kg (77 lbs.)	106 kg (233 lbs.)	247 kg (543 lbs.)
C	210 kg (462 lbs.)	370 kg (810 lbs.)	380 kg (830 lbs.)

Suggested maximum table loads  
 A = Workpiece, B = Chuck, C = A+B

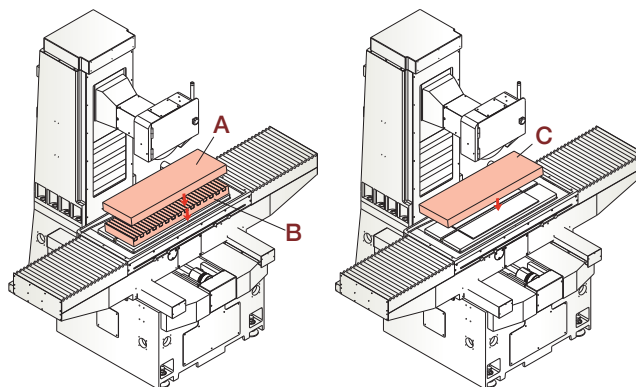

# Machine Dimensions

Units: mm (")

## SMART-H/B2440III / SMART-H/B2460III / SMART-H/B2480III

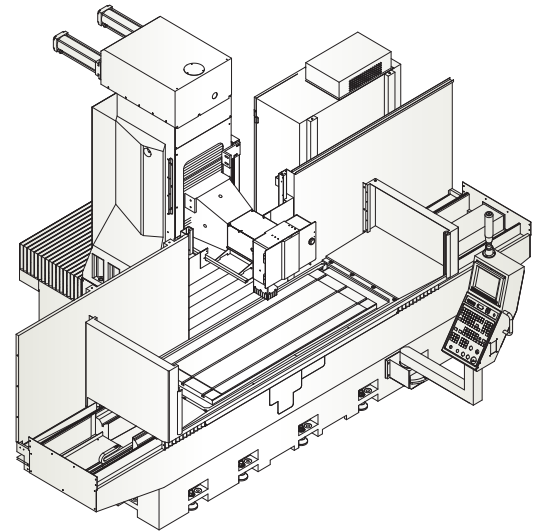
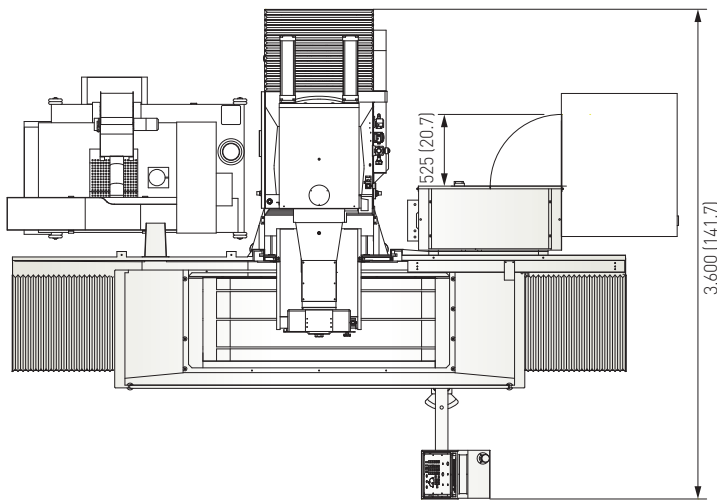

Note: Machine shown with optional accessories.

SMART-H/B2440III: 3,500 (137.8)  
 SMART-H/B2460III: 4,500 (177.2)  
 SMART-H/B2480III: 6,000 (236.2)

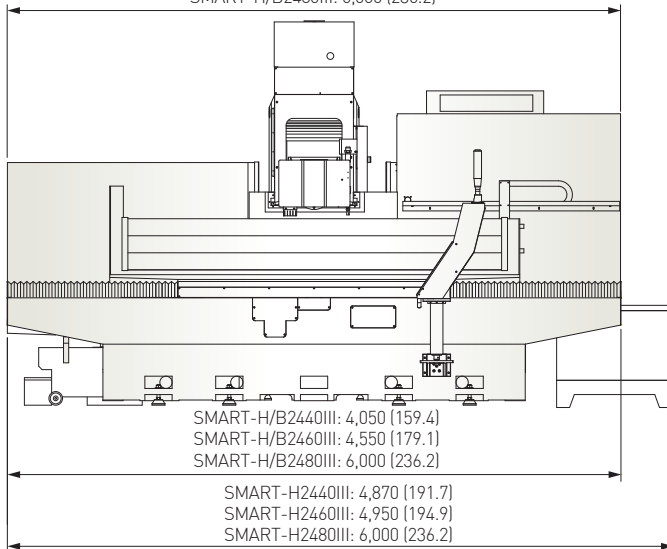

SMART-H/B2440III: 4,050 (159.4)  
 SMART-H/B2460III: 4,550 (179.1)  
 SMART-H/B2480III: 6,000 (236.2)

SMART-H2440III: 4,870 (191.7)  
 SMART-H2460III: 4,950 (194.9)  
 SMART-H2480III: 6,000 (236.2)

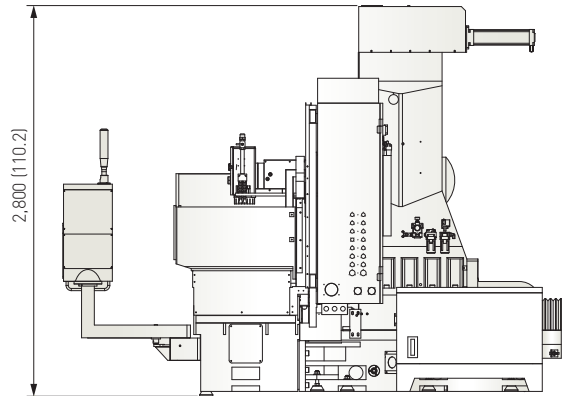

## Loading Capacity

Item	SMART-H/B2440III	SMART-H/B2460III	SMART-H/B2480III
A	1,120 kg (2,464 lbs.)	1,305 kg (2,811 lbs.)	1,240 kg (2,728 lbs.)
B	380 kg (836 lbs.)	495 kg (1,089 lbs.)	760 kg (1,672 lbs.)
C	1,500 kg (3,300 lbs.)	1,800 kg (3,900 lbs.)	2,000 kg (4,400 lbs.)

Suggested maximum table loads  
 A = Workpiece, B = Chuck, C = A+B

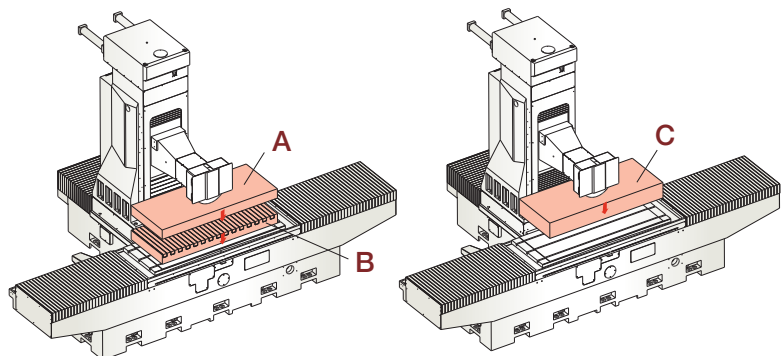





A full line of standard and optional accessories adds flexibility to SMART-III Series grinders

## Accessories

### Standard accessories

- Wheel flange (clamping width):  
SMART-818 series: 6.3~19 mm (0.2" ~ 0.7")  
SMART-12/16 series: 19~38 mm (0.7" ~ 1.5")  
SMART-24 series: 32~50 mm (1.3" ~ 2.0")
- Grinding wheel (OD x Width x Bore):  
SMART-818 series: Ø205 x 12.7 x Ø31.7 mm (Ø8" x 0.5" x Ø1.3")  
SMART-12/16 series: Ø355 x 50 x Ø127 mm (Ø14" x 2" x Ø5")  
SMART-24 series: Ø405 x 75 x Ø127 mm (Ø16" x 3" x Ø5")
- Wheel mounting/dismounting tools
- Hole plugs
- Splash guard
- Heat exchanger
- Oil chiller (SMART-24 series only) Standard on H models. Minimizes thermal expansion and maintains consistent accuracy and repeatability during heavy-duty machining conditions.
- Frequency inverter
- Linear scale on Y-axis (SMART-24 series only)
- Leveling pad: SMART-818 series: 3 pieces  
SMART-12/16 series: 6 pieces  
SMART-2440 series: 14 pieces  
SMART-2460 series: 18 pieces  
SMART-2480 series: 20 pieces

- Leveling screws and nuts:  
SMART-818 series: 3 sets  
SMART-12/16 series: 6 sets  
SMART-2440 series: 14 sets  
SMART-2460 series: 18 sets  
SMART-2480 series: 20 sets
- Toolbox includes balancing arbor (wheel), hook wrench, hex head wrench, ring spanner (41 mm)

### Optional accessories

- Chuck control
- Electromagnetic chuck
- Diamond dresser
- Balancing stand roller type
- Coolant system with auto paper feeding device
- Coolant system with auto paper feeding device and magnetic separator
- Hydraulic tank and oil cooler
- Grinding wheel dynamic balancer (SMART-12/16/24 series)
- Rotary tables
- Single disc dresser
- Dual support rolling type wheel dresser

# Specifications

Item	Description	SMART-H818III	SMART-B818III	SMART-H1224III	SMART-B1224III	SMART-H1640III	SMART-B1640III	
Control system		SMART iControl						
Capacity	Max. grinding length-longitudinal	460 mm (18.1")		610 mm (24.0")		1,015 mm (40.0")		
	Max. grinding width-crosswise	200 mm (7.9")		305 mm (12.0")		406 mm (16.0")		
	Distance between table to spindle centerline	445 mm (17.5")	395 mm (15.6")		600 mm (23.6")		600 mm (23.6")	
	Max. table load	210 kg (462 lbs.)		370 kg (810 lbs.)		380 kg (830 lbs.)		
Table	Table size	200 x 460 mm (7.9" x 18.1")		300 x 600 mm (11.8" x 23.6")		400 x 1,000 mm (15.7" x 39.4")		
	T-slots (width x pitch x no.)	12 mm x 124 mm x 1 (0.5" x 4.9" x 1)		14 mm x 152.5 mm x 1 (0.6" x 6.0" x 1)		14 mm x 100 mm x 3 (0.6" x 3.9" x 3)		
	Height from the machine table to ground	1,015 mm (40.0")	1,060 mm (41.7")		975 mm (38.4")		980 mm (38.6")	
	Table speed (variable)	0.1-25 m/min (0.33-82 fpm)	0-20 m/min (0-65.6 fpm)		5-25 m/min (16-82 fpm)	0-20 m/min (0-65.6 fpm)	5-25 m/min (16-82 fpm)	0-20 m/min (0-65.6 fpm)
	Max. table travel	510 mm (20.1")		700 mm (27.6")		1,100 mm (43.3")		
Transverse movement (Z)	Max. travel	220 mm (8.7")		350 mm (13.8")		450 mm (17.7")		
	Feed speed	0-3,000 mm/min (0-10 fpm)						
	Min. input	0.001 mm (0.0001")						
Wheelhead elevation (Y)	Max. travel	340 mm (13.4")	290 mm (11.4")		440 mm (17.3")			
	Feed speed	0-3,000 mm/min (0-10 fpm)						
	Min. input	0.001 mm (0.0001")						
Spindle	Spindle speed (variable speed)	1,000-7,000 rpm			500-1,800 rpm			
	Spindle motor	3 kW (4 HP)			11 kW (15 HP)			
Motors	Axis motors (X / Y / Z)	Y/Z: 850 W	X: 1.8 kW Y/Z: 850 W		Y/Z: 850 W	X: 2.9 kW Y/Z: 850 W		
	Hydraulic motor	1 HP	—		3 HP	—		
Wheel dimension	OD x Width x Bore	Ø205 x 12.7 x Ø31.75 mm (Ø8" x 0.5" x Ø1.3")			Ø355 x 50 x Ø127 mm (Ø14" x 2" x Ø5")			
Power and air requirement	Power required	11 kVA		23 kVA		25 kVA		
	Total air consumption	6 kg/cm <sup>2</sup> (86 psi), 200 NL/min (7 cfm)						
Tank capabilities	Hydraulic tank capacity	90 L (23 gals.)	—		150 L (39 gals.)	—		
Machine dimensions	Floor space (W x D x H)	2,510 x 2,515 x 2,010 mm (98.8" x 99.0" x 79.0")	2,510 x 2,015 x 2,010 mm (98.8" x 79.3" x 79.0")		4,020 x 2,450 x 2,080 mm (158.3" x 96.5" x 81.9")	3,160 x 2,450 x 2,080 mm (124.4" x 96.5" x 81.9")	4,450 x 2,655 x 2,080 mm (175.2" x 104.5" x 81.9")	3,590 x 2,655 x 2,080 mm (141.3" x 104.5" x 81.9")
	Net weight	1,550 kg (3,400 lbs.)		3,200 kg (7,000 lbs.)		4,200 kg (9,200 lbs.)		
Accuracy	Positioning accuracy	0.004 mm (0.00016")			0.005 mm (0.0002")			
	Repeatability accuracy	0.003 mm (0.00012")			0.003 mm (0.00012")			
	Accuracy standard	ISO 1986-1						

All content is for reference only and may be subject to change without prior notice or obligation.

SMART-H2440III	SMART-B2440III	SMART-H2460III	SMART-B2460III	SMART-H2480III	SMART-B2480III
SMART iControl					
1,000 mm (39.4")		1,500 mm (59.1")		2,000 mm (78.7")	
		600 mm (23.6")			
		850 mm (33.5")			
1,500 kg (3,300 lbs.)		1,800 kg (3,900 lbs.)		2,000 kg (4,400 lbs.)	
600 x 1,000 mm (23.6" x 39.4")		600 x 1,500 mm (23.6" x 59.1")		600 x 2,000 mm (23.6" x 78.7")	
14 mm x 210 mm x 3 (0.6" x 8.3" x 3)					
880 mm (34.6")					
5~30 m/min (16~98.4 fpm)	0~20 m/min (0~65.6 fpm)	5~30 m/min (16~98.4 fpm)	0~20 m/min (0~65.6 fpm)	5~30 m/min (16~98.4 fpm)	0~20 m/min (0~65.6 fpm)
1,100 mm (43.3")		1,600 mm (63.0")		2,100 mm (82.7")	
675 mm (26.6")					
0~5,000 mm/min (0~16.4 fpm)					
0.001 mm (0.0001")					
850 mm (33.5")					
0~2,000 mm/min (0~6.56 fpm)					
0.001 mm (0.0001")					
500~1,800 rpm					
11 kW (15 HP)					
Y/Z: 3 kW	X: 7.5 kW Y/Z: 3 kW	Y/Z: 3 kW	X: 7.5 kW Y/Z: 3 kW	Y/Z: 3 kW	X: 7.5 kW Y/Z: 3 kW
5 HP	—	7.5 HP	—	7.5 HP	—
Ø405 x 75 x Ø127 mm (Ø16" x 3" x Ø5")					
47 kVA					
6 kg/cm <sup>2</sup> (86 psi), 200 NL/min (7 cfm)					
250 L (66 gals.)	—	250 L (66 gals.)	—	250 L (66 gals.)	—
4,870 x 3,600 x 2,800 mm (191.7" x 141.7" x 110.2")	4,050 x 3,600 x 2,800 mm (159.4" x 141.7" x 110.2")	4,950 x 3,600 x 2,800 mm (194.9" x 141.7" x 110.2")	4,550 x 3,600 x 2,800 mm (179.1" x 141.7" x 110.2")	6,000 x 3,600 x 2,800 mm (236.2" x 141.7" x 110.2")	
8,400 kg (18,500 lbs.)		9,800 kg (21,600 lbs.)		10,600 kg (23,300 lbs.)	
0.006 mm (0.00024")					
0.004 mm (0.00016")		Y / Z: 0.004 mm (0.00016")		X: 0.006 mm (0.00024") Y/Z: 0.004 mm (0.00016")	
Y / Z: 0.004 mm (0.00016")					
ISO 1986-1					

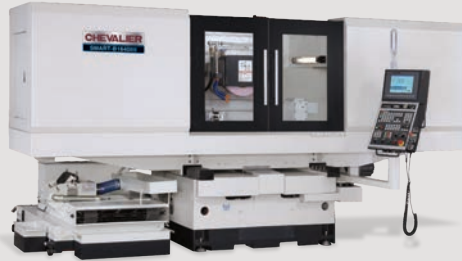

Grinding  
Machines

SMART  
Grinding Machines

Turning  
Machines

Milling  
Machines

**CHEVALIER**<sup>®</sup>  
Grinding / Turning / Milling

We shape your ideas.<sup>™</sup>

Headquarters  
FALCON MACHINE TOOLS CO., LTD.  
No. 34, Hsing Kong Road, Shang Kang, Chang Hua  
TAIWAN 50971  
Tel: +886 4 799 1126 Fax: +886 4 798 0011  
▶ [www.chevalier.com.tw](http://www.chevalier.com.tw)  
[overseas@chevalier.com.tw](mailto:overseas@chevalier.com.tw)

U.S.A. Headquarters  
CHEVALIER MACHINERY INC.  
9925 Tabor Place, Santa Fe Springs, CA 90670 U.S.A.  
Tel: (562) 903 1929 Fax: (562) 903 3959  
▶ [www.chevalierusa.com](http://www.chevalierusa.com)  
[info@chevalierusa.com](mailto:info@chevalierusa.com)