

ROYAL
Royal Precision Tools Corporation

High Precision Spindles Solutions

Total Solution • State of the Art



PRECISION

STABILITY

RIGIDITY

EFFICIENCY

Motorized Spindle

High Precision

- ▶ High dynamic rotary accuracy
- ▶ Balancing adjustment within G1, low vibration
- ▶ Modularized easily
- ▶ Low thermal displacement, high stability
- ▶ Short overall length, low inertia

High Efficiency

- ▶ High motor power, high moments of inertia



Model	Housing OD (mm)	Max. Speed (rpm)	Nose	Spindle Bore Hole (mm)	Bearing ID (mm)	Lubrication	Motor Specification	Power S1 (kW)	Torque S1 (Nm)	Cooling	Weight (kg)	Options
REA506	Ø185	6000	A2-5	56.5	Ø90+Ø75	Grease	160/110/220(380V)	11	74.9	Oil	Approx. 250	Brake Disc
REA613	Ø290	5000	A2-6	76.3	Ø120+Ø100		SIMENS 1FE1114-6WW31	18.6	200		Approx. 230	
REA609	Ø345	4500	A2-6	76	Ø140+Ø115		FANUC Bil 200M/6000-B(200V)	18.5	343		Approx. 365	
REA813	Ø340	4000	A2-8	91	Ø140+Ø115		ATE AC 270/250/8	18.5	430.9		Approx. 360	

REA506

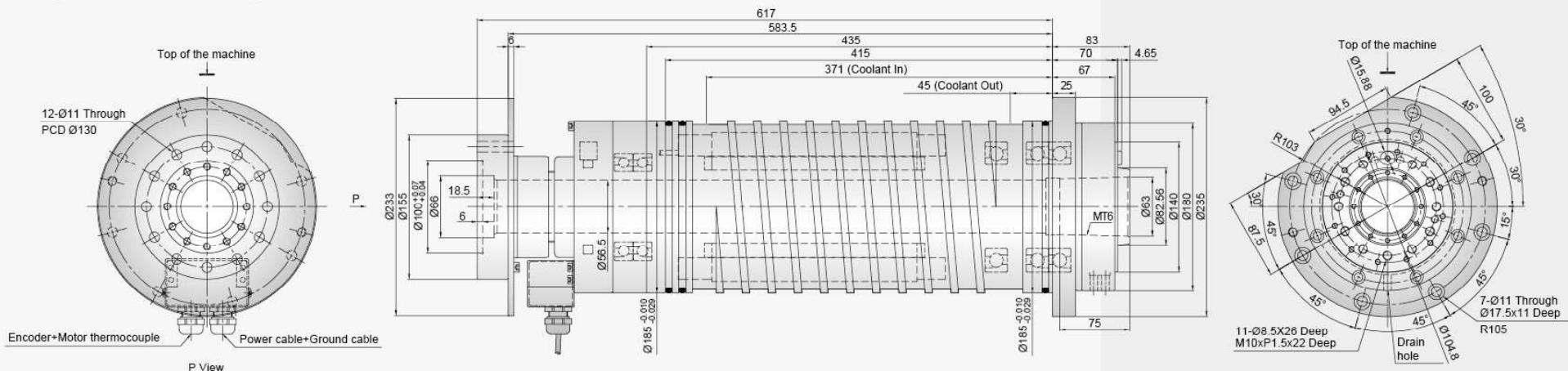

REA613

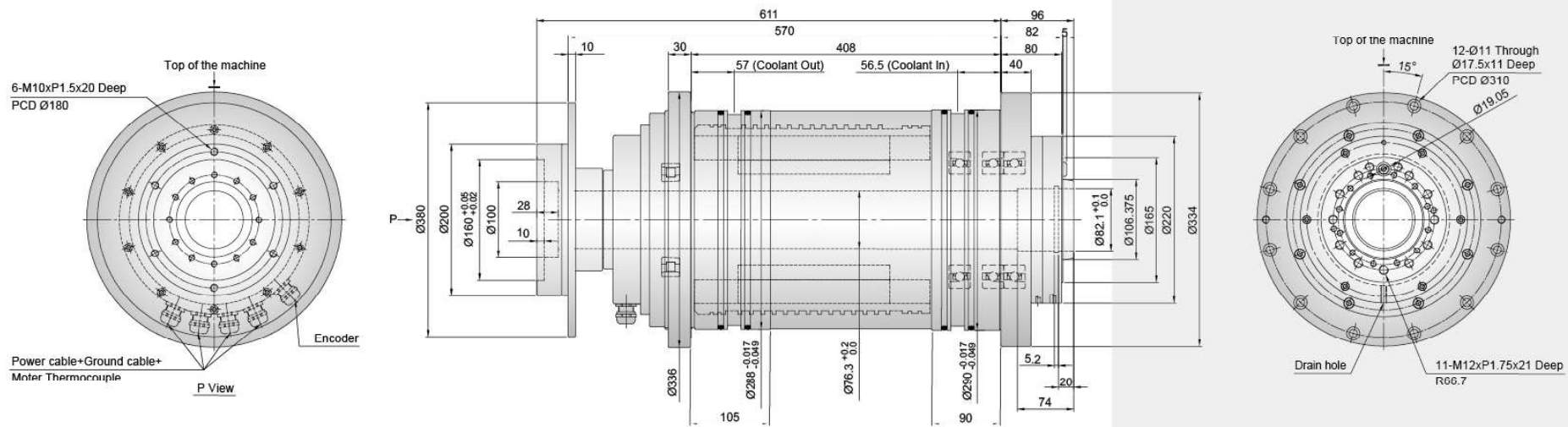

Belt-Drive Spindle

- ▶ High dynamic rotary accuracy
- ▶ High axial and radial rigidity
- ▶ Stable thermal temperature



Model	Housing OD (mm)	Max. Speed (rpm)	Nose	Spindle Bore Hole (mm)	Bearing ID (mm)	Lubrication	Weight (kg)	Options
RA4007	Ø150	8000	A2-4	45	Ø70	Grease	Approx. 47	Brake Disc Encoder
RA5005	Ø170	6000	A2-5	56	Ø80		Approx. 75	
RA6023	Ø200	5000	A2-6	66	Ø100+Ø90		Approx. 90	
RA8001	Ø260	3500	A2-8	92/98	Ø130+Ø120		Approx. 200	
RA1113	Ø286	2800	A2-11	117.5	Ø160+Ø150		Approx. 313	
RA1503	Ø400	1000	A2-15	184	Ø240+Ø220		Approx. 610	

RA4007

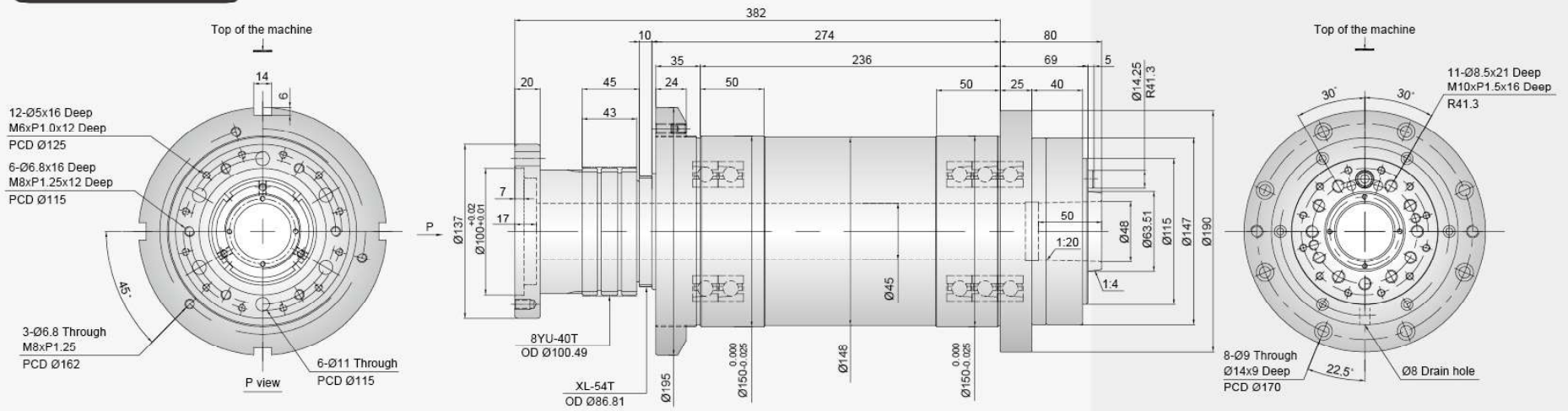

RA5005

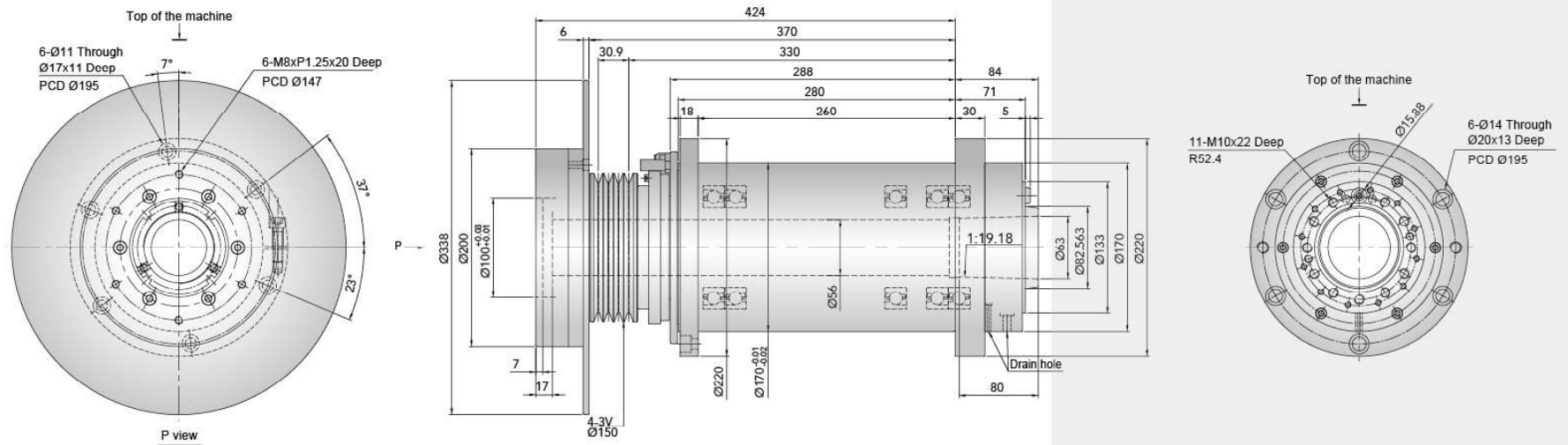

RA6023

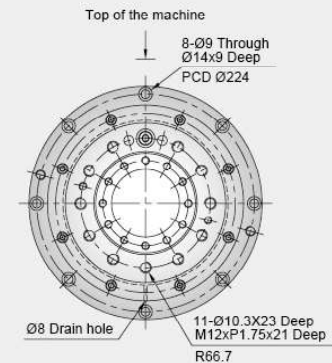
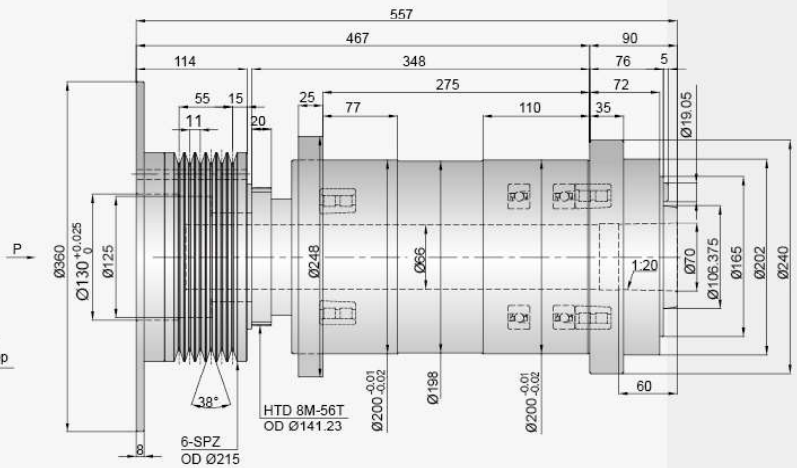
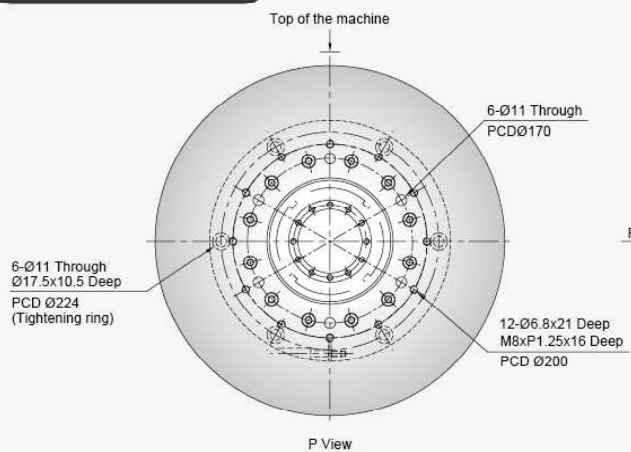

RA8001

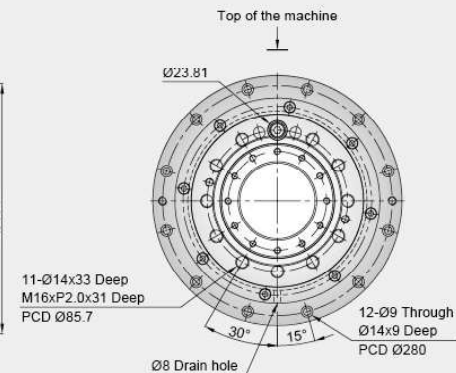
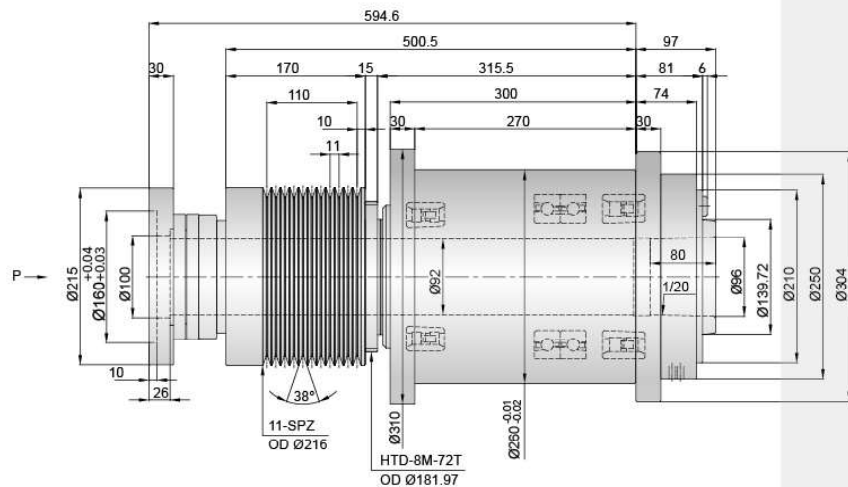
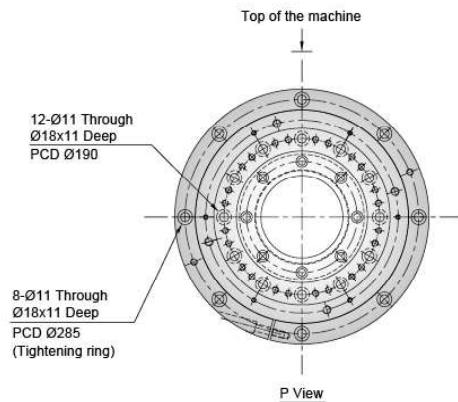

RA1113

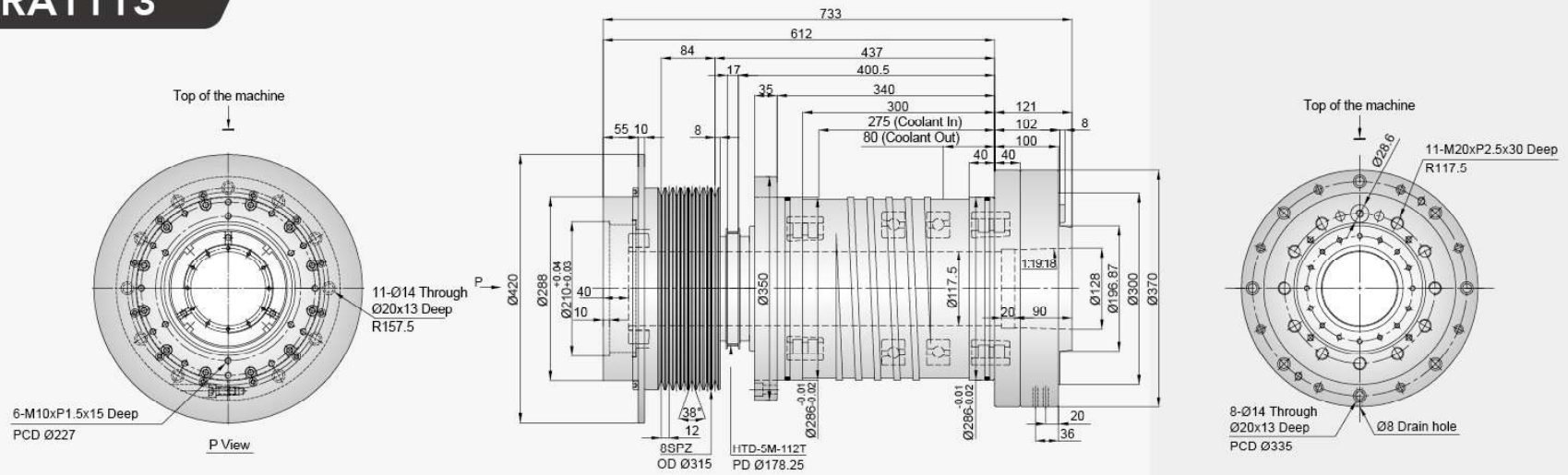

RA1503

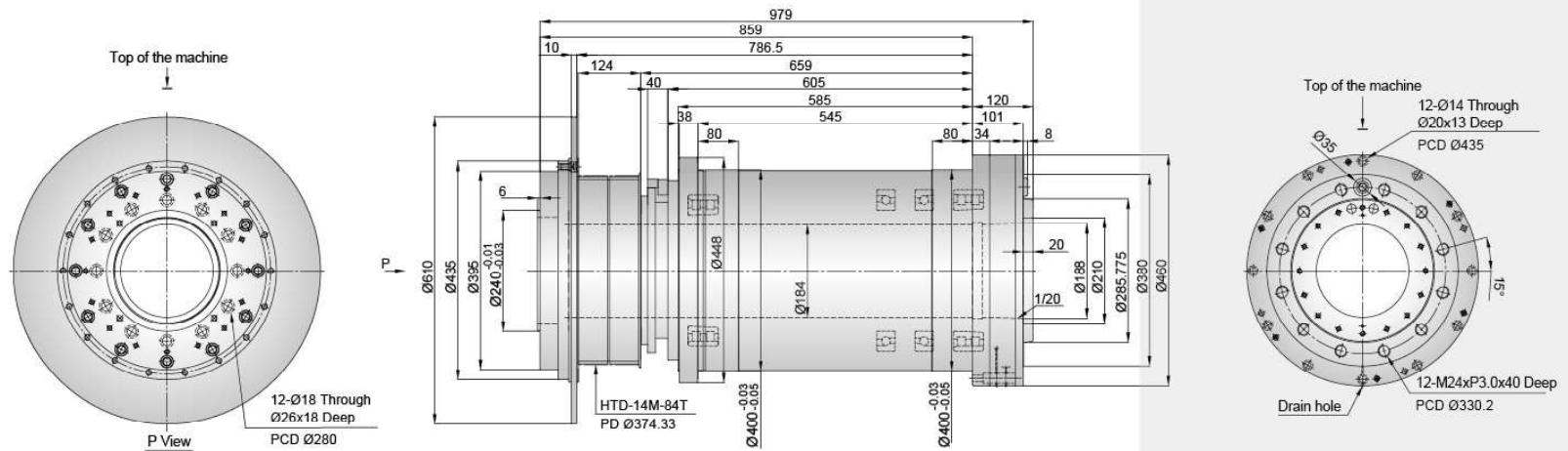

Your Spindle Solutions
Speed, Precision, Rigidity

ROYAL

Royal Precision Tools Corporation

Head office

No. 21, Sec. 1, Zhongshan Rd., Wuri Dist.,
Taichung City 414, Taiwan

TEL: +886 4 2338 2068

FAX: +886 4 2338 2161

E-mail : royal_sa@royal-spindles.com.tw

Jiji, Nantou

No. 66, Zhongji Rd., Jiji Township,
Nantou County 552, Taiwan

TEL: +886 4 2338 2068

FAX: +886 49 276 2812



www.royal-spindles.com