

Precision tools

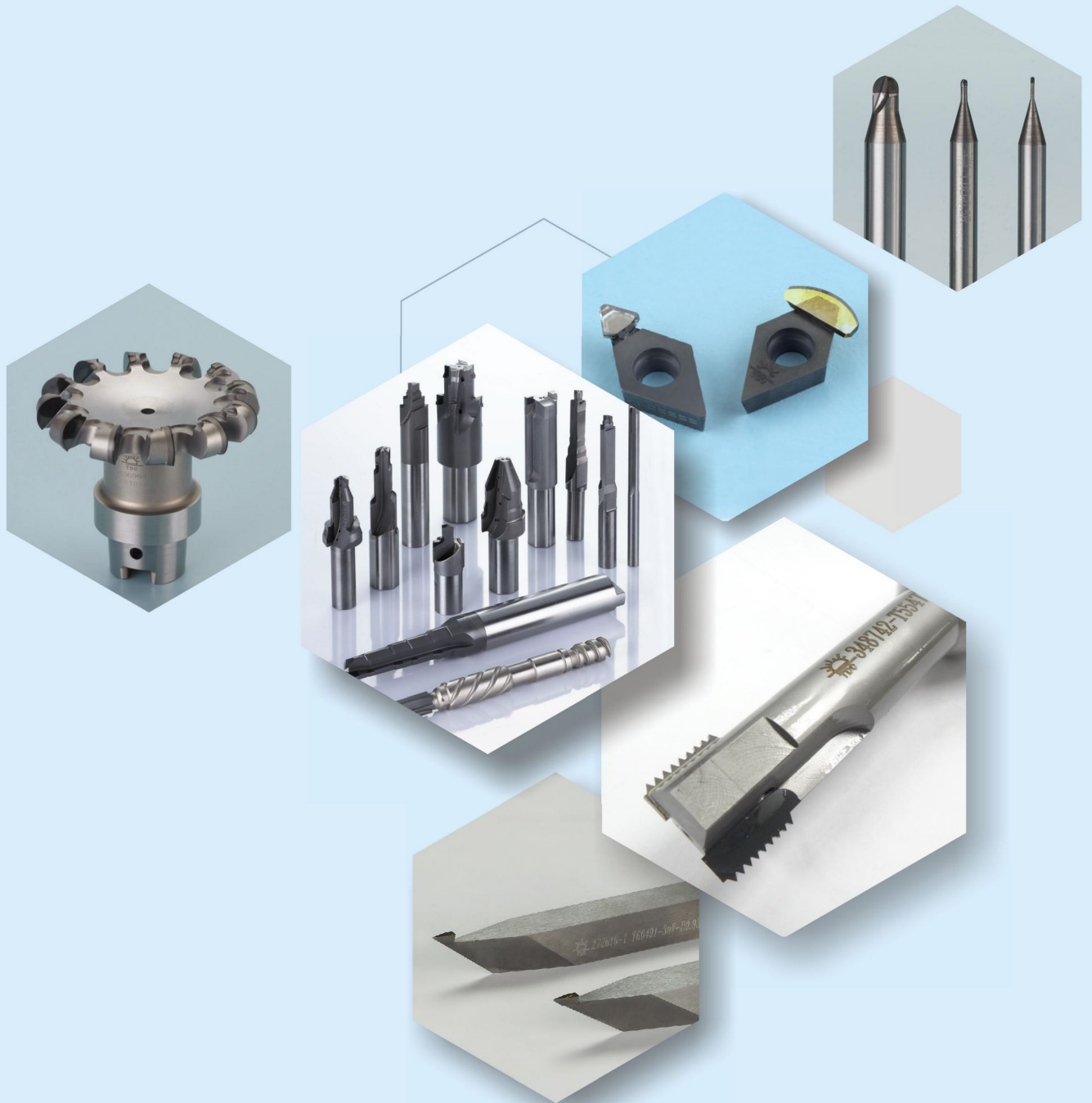

Precision tools and applications

Contents

01	Tools for 3C product casing machining	P 01
02	Tools for optical die machining	P 04
03	Tools for glasses lens machining	P 06
04	Tools for backlight module machining	P 08
05	Tools for PU guide roller machining	P 10
06	Tools for automobile and motorcycle industry	P 13
07	Tools for woodworking industry	P 14
08	Tools for composite material machining	P 17
09	Tools for precision mold machining	P 18
10	Wear-resistant parts	P 22

01

Tools for 3C product casing machining

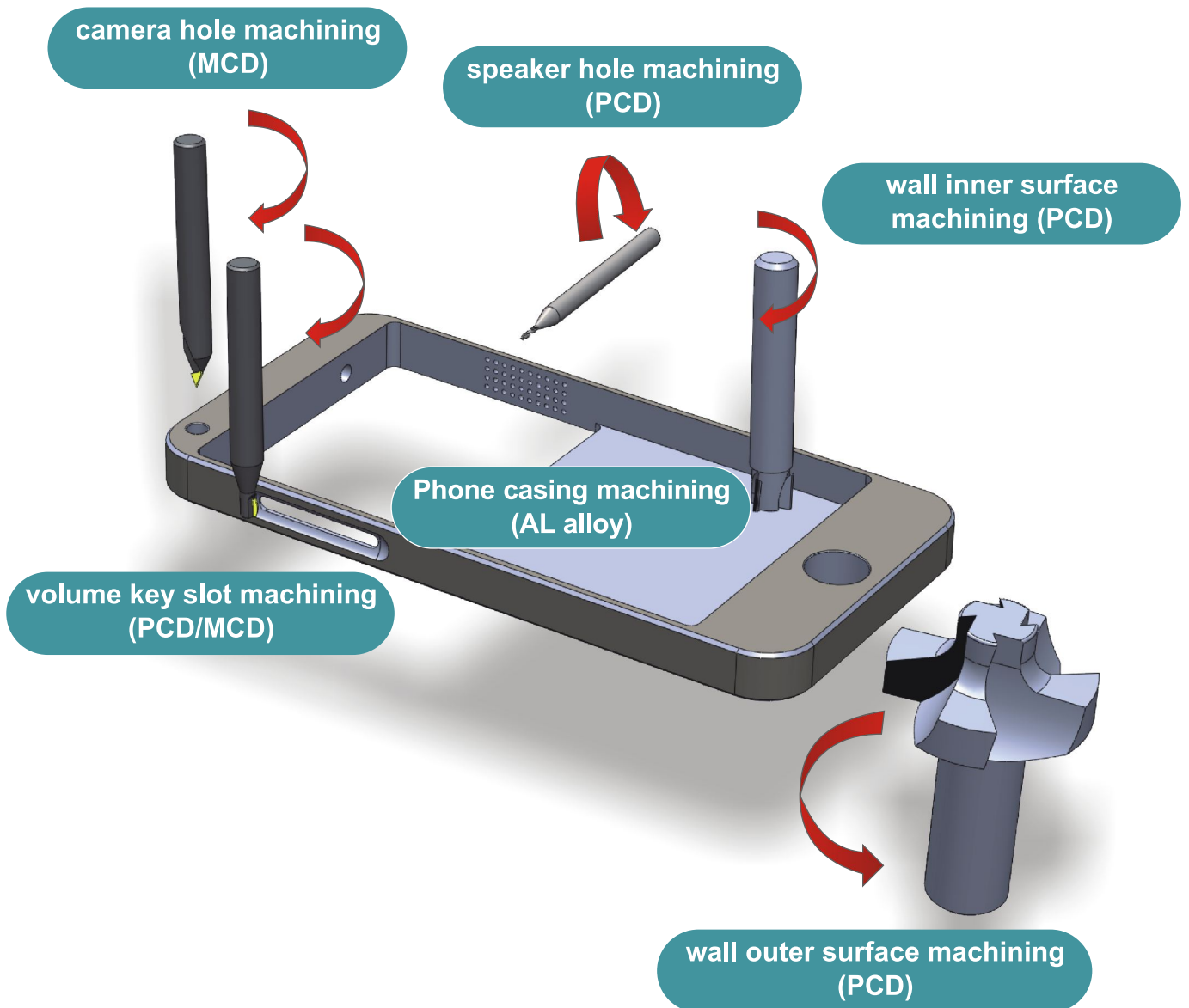

1.MCD half R end milling cutter for earphone jack and earpiece machining

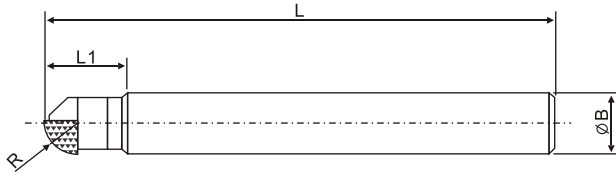

Product Specification			
unit: mm			
Nose Angle (R)	Cutting Edge Length (L1)	Shank Length (L)	Shank Diameter ($\varnothing B$)
0.75	3	50	4
1.0	10	50	4
1.5	10	50	4
2.0	10	50	4
2.5	10	50	6
3.0	10	50	6

Cutting edge material

Synthetic monocrystalline diamond (MCD, MCC)

Features

- 1.0.75 mm~3.0mm R angle design
- 2.Top of cutter shows no broken edge under 500x magnification:
- 3.Special specifications available on customer order

Applications

- 1.Cellphone earpiece machining
- 2.Aluminum workpiece machining

2.MCD cutter for camera hole machining

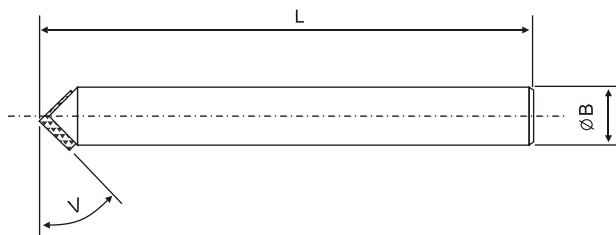

Product Specification		
unit: mm		
V angle (V)	Shank Diameter ($\varnothing B$)	Length (L)
10°	6	50
30°	6	50
40°	6	50
45°	6	50
50°	6	50
60°	6	50

Cutting edge material

Synthetic monocrystalline diamond (MCD, MCC)

Features

- 1.10° ~ 60° design, angle tolerance $\pm 6'$
- 2.Top of cutter shows no broken edge under 500x magnification
- 3.Special specifications available on customer order

Applications

- 1.Cellphone casing machining
- 2.Aluminum workpiece edge chamfer machining

3.MCD straight edge milling cutter for cellphone casing machining

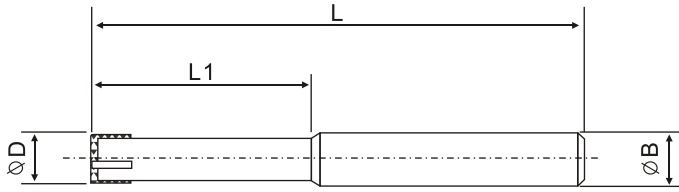

Product Specification			
unit: mm			
Diameter of Gyration(ØD)	Cutting Edge Length (L1)	Shank Length (L)	Shank Diameter (ØB)
2.5	3	50	4
3.0	5	50	4
4.0	10	50	4
5.0	10	50	4
6.0	10	50	6

Cutting edge material

Synthetic monocrystalline diamond (MCD, MCC)

Features

- 1.2.65 mm ~ 6.0mm radius of gyration design
- 2.Top of cutter shows no broken edge under 500x magnification
- 3.Special specifications available on customer order

Applications

- 1.Cellphone casing level machining
- 2.Face milling machining

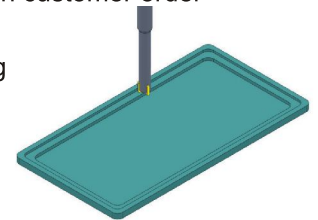

4.Monocrystalline chamfer cutter for metallic cellphone casing

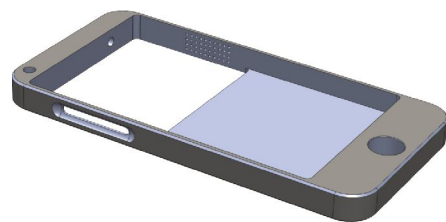
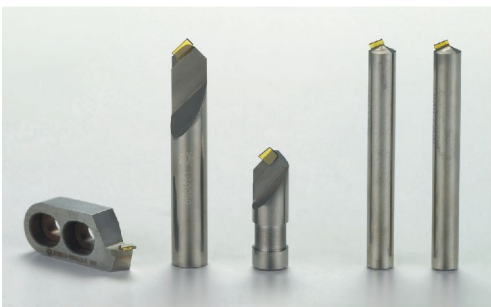

5.MCD side R profile milling cutter for cellphone casing key slot

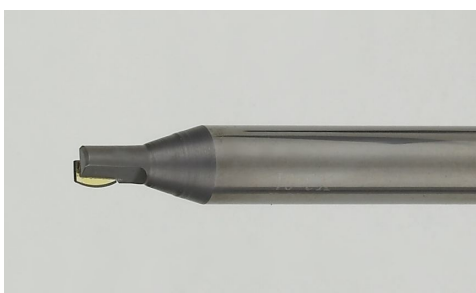

6.PCD cutter for cellphone casing forming machining



02

Tools for optical die machining

Application: optical lens die, spherical surface, non-spherical surface, micro structure machining.

Process capacity: V-angle: $35^{\circ} \sim 55^{\circ} \pm 30'$

R angle: $R0.02 \sim R0.1\text{mm} \pm 0.05$

Waviness: $0.1 \mu\text{m}$ or above

Request: No broken edge under 1000x magnification

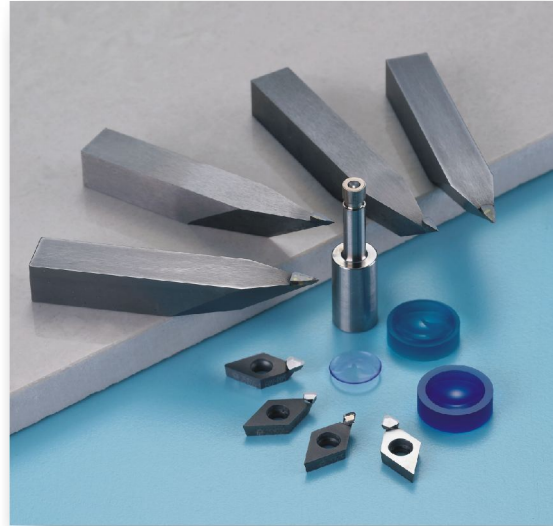
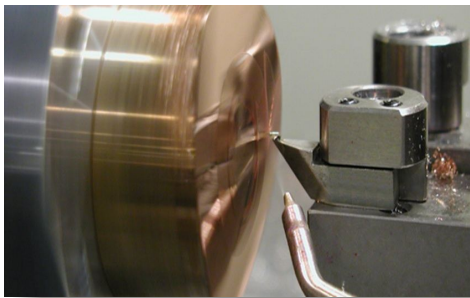

MCD spherical surface/non-spherical surface cutter delivery inspection sheet

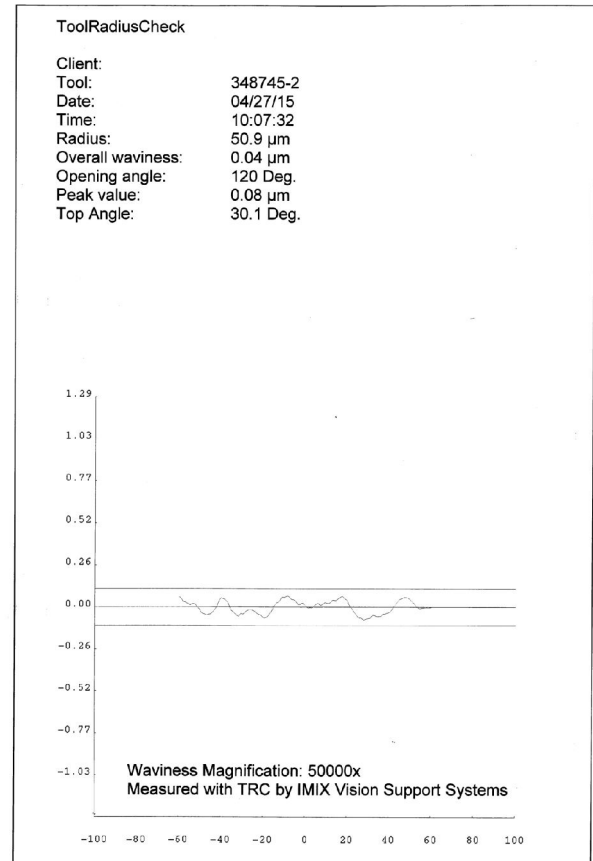
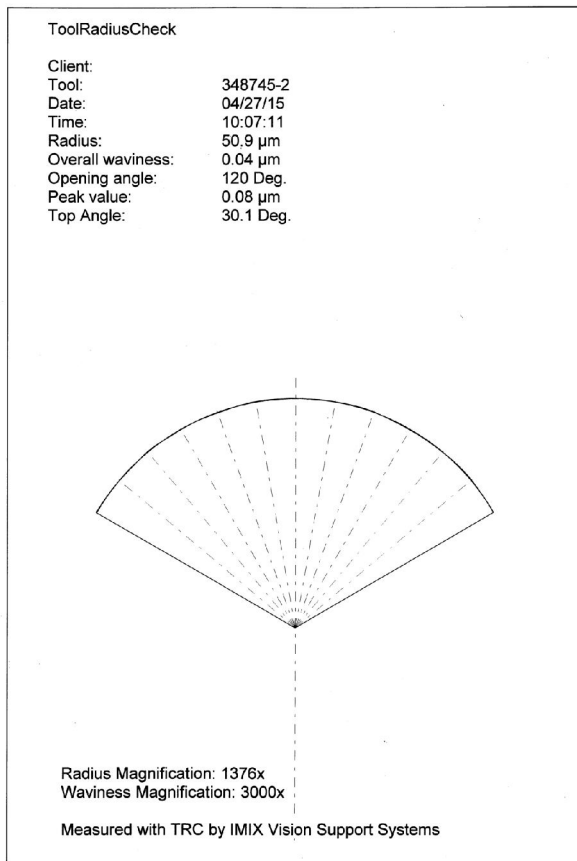

1.Spherical surface/non-spherical surface optical die cutter

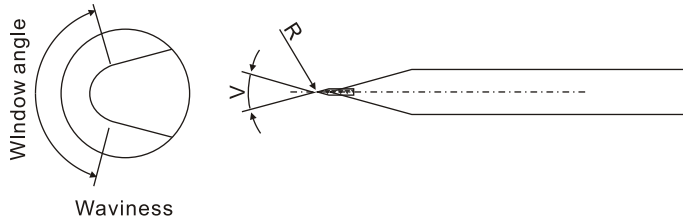

Product Specification			
unit: mm			
V angle (V)	Nose Radius (R)	Waviness	Window Angle
30° ~ 90°	0.01~0.05	50nm~100nm	80° ~ 140°
30° ~ 90°	0.06~0.1	100nm~200nm	80° ~ 140°
30° ~ 90°	0.5~1	200nm~1000nm	80° ~ 140°
30° ~ 90°	1~	1000nm~	80° ~ 140°

Cutting edge material

- Synthetic monocrystalline diamond (MCD, MCC)
- Natural monocrystalline diamond (ND)

Features

- 1.Minimum cutter V-angle: 20°
- 2.Minimum nose radius: 0.01mm
- 3.Top of cutter shows no broken edge under 1000x magnification
- 4.Waviness: 0.05 μ m or less
- 5.Along with profile geometry waviness inspection form
- 6.Special specifications available on customer order

Applications

- 1.Contact lenses die machining
- 2.Optical lens die machining

2.Spherical surface / non-spherical surface contact lenses machining cutter

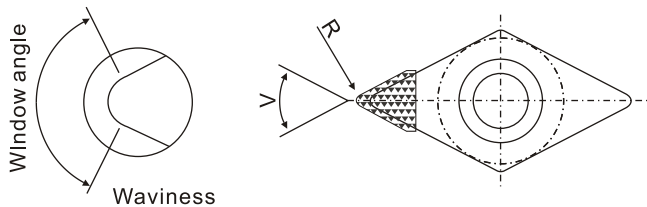

Product Specification			
unit: mm			
V angle (V)	Nose Radius (R)	Waviness	Window Angle
35° ~ 55°	0.01~0.05	50nm~100nm	100° ~ 140°
35° ~ 55°	0.06~0.1	100nm~200nm	100° ~ 140°
35° ~ 55°	0.5~1	200nm~1000nm	100° ~ 140°
35° ~ 55°	1~	1000nm~	100° ~ 140°

Cutting edge material

- Synthetic monocrystalline diamond (MCD, MCC)
- Natural monocrystalline diamond (ND)

Features

- 1.Maximum nose radius: 5mm
- 2.Top of cutter shows no broken edge under 1000x magnification
- 3.Waviness: 0.05um or less
- 4.Along with profile geometry waviness inspection form
- 5.Special specifications available on customer order

Applications

- 1.Contact lenses machining

03

Tools for glasses lens machining

1. Satisloh equipment glasses lens machining cutter



12 cutting edge PCD milling cutter (roughing)

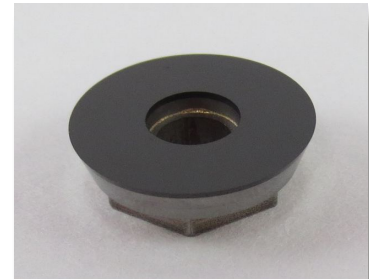

Glasses lens roughing PCD turning tool



Glasses lens roughing PCD turning tool (R2)



Glasses lens finishing ND turning tool (R2, R5)

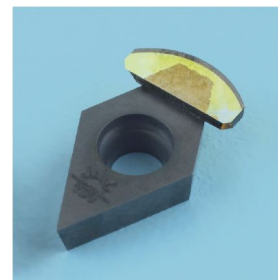

Glasses lens finishing MCD turning tool (R2, R5)



Glasses lens finishing MCD turning tool (R2, R5)



Glasses lens roughing PCD turning tool (R2, R5)

2.Schneider equipment glasses lens machining cutter



12 cutting edge PCD milling cutter (roughing)

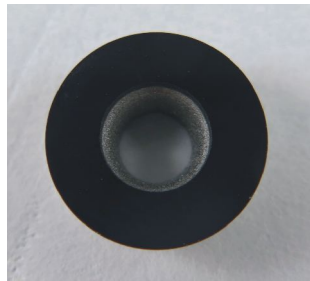

Glasses lens roughing PCD turning tool

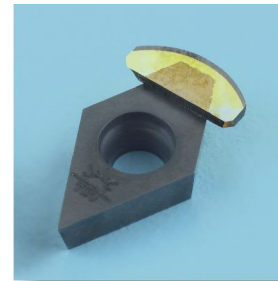

Glasses lens finishing MCD turning tool (R2, R5)

3.OPTO-TECH equipment glasses lens cutter



8 cutting edge PCD milling cutter (roughing)



Glasses lens roughing PCD turning tool



Glasses lens finishing MCD turning tool (R2, R5)

4. MEI equipment glasses lens machining cutter



Glasses lens peripheral machining PCD forming cutter

04

Tools for backlight module machining

Application: MCD cutter for backlight board polishing

Manufacturing capacity: $R9.0 \pm 0.2 \sim R50 \pm 5.0$

Dimension: R6.35-6.2 (H)-12H-33L:

No broken edge under 500x magnification

1. Polishing cutter

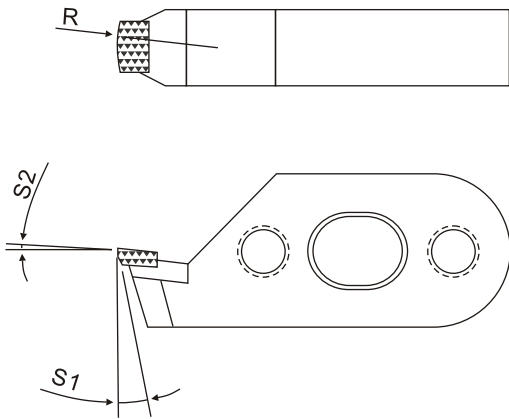

Product Specification		
unit: mm		
Nose Radius (R)	Front Clearance Angle (S1)	Back rake Angle (S2)
0	5° ~ 15°	0° ~ 5°
5	5° ~ 15°	0° ~ 5°
10	5° ~ 15°	0° ~ 5°
20	5° ~ 15°	0° ~ 5°
50	5° ~ 15°	0° ~ 5°
100	5° ~ 15°	0° ~ 5°

Cutting edge material

Synthetic monocrystalline diamond (MCD, MCC)

Polycrystalline diamond sintered mass (PCD)

Features

1. 1.0 mm-100mm front R angle design

2. Top of MCD cutter shows no broken edge under 500x magnification

3. Special specifications available on customer order

Applications

1. Polarizer roughing/finishing machining

2. Backlight roughing/finishing machining

2.MCD cutter for brightness enhancement film die

Manufacturing capacity :

V-angle: 30° ~150° , accuracy: $\pm 6'$

R angle: 0~0.05 (+0.02/-0)

Request: No broken edge under 1000x magnification

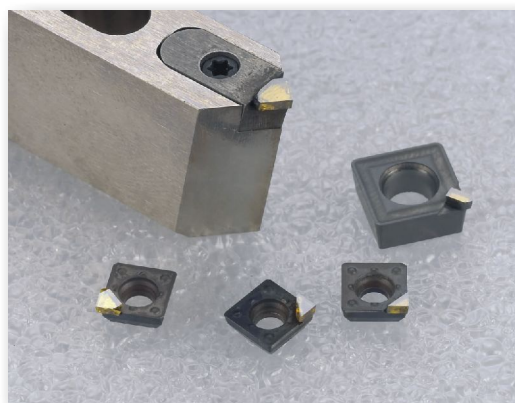
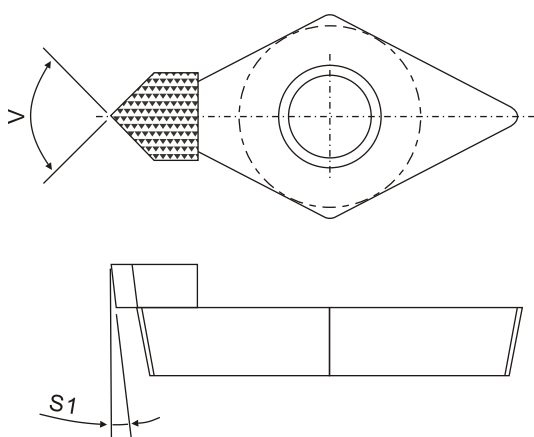

Product Specification		
Specification	V-angle (V)	Front Clearance Angle (S1)
DCMW11T300	50°	5° ~ 15°
DCMW070200	50°	5° ~ 15°
DCMW11T300	60°	5° ~ 15°
DCMW070200	60°	5° ~ 15°
SPMT060204	90°	5° ~ 15°
SPMT060204	90°	5° ~ 15°

Cutting edge material

Synthetic monocrystalline diamond (MCD, MCC)

Features

1. Minimum angle tolerance: $\pm 6'$
2. Top of cutter shows no broken edge under 1000x magnification
3. Special specifications available on customer order

Applications

1. Phosphorus nickel alloy roller micro groove machining
2. Oxygen-free copper roller micro groove machining

05

Tools for PU guide roller machining

V-groove MCD cutter for PU guide roller machining

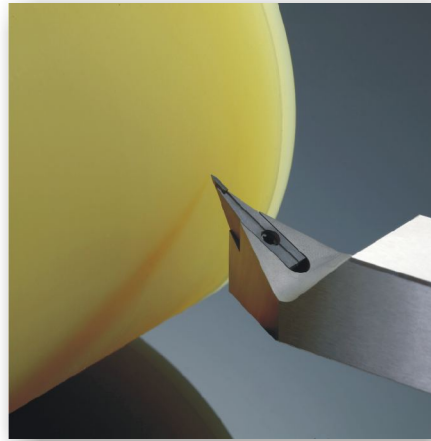
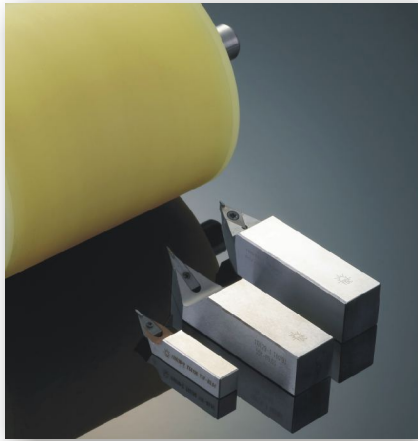

Process capacity :

V-angle: $30^{\circ} \sim 90^{\circ}$, $\pm 30'$

R angle: R0.01~R0.1mm

Accuracy up to 5um as required by customer

Request: No broken edge under 200x magnification

1.MCD Turning tool for PU guide roller machining (with shank type)

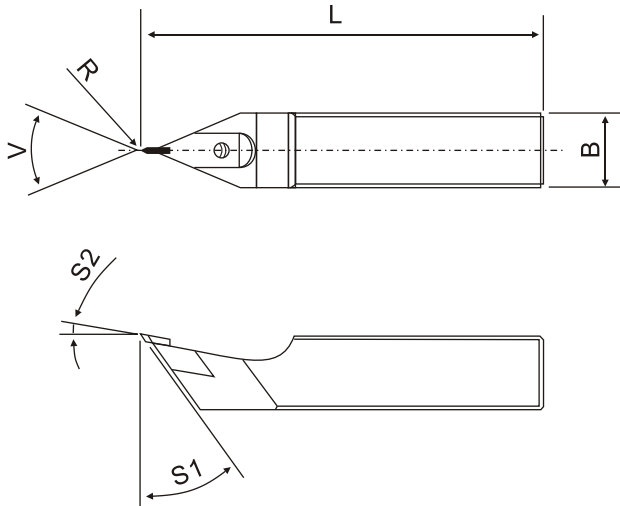

Cutting edge material

Synthetic monocrystalline diamond (MCD, MCC)

Features

1. Minimum cutter V-angle: 25°
2. Minimum nose radius: 0.01mm
3. Top of cutter shows no broken edge under 500x magnification
4. Special specifications available on customer order

Applications

1. PU roller groove machining
2. PE roller groove machining



Product Specification					
unit: mm					
V-angle (V)	Nose Radius (R)	Shank width (B)	Shank Length (L)	Front Clearance Angle (S1)	Back rake Angle (S2)
30°	0.02	13	60	30°	10°
30°	0.02	25	150	10°	30°
45°	0.02	13	60	30°	10°
45°	0.02	25	150	10°	30°
50°	0.02	13	60	30°	10°
50°	0.02	25	150	10°	30°
60°	0.02	13	60	30°	10°
60°	0.02	25	150	10°	30°
90°	0.02	13	60	30°	10°
90°	0.02	25	150	10°	30°

2.MCD Turning tool for PU guide roller machining (Throw-away type)

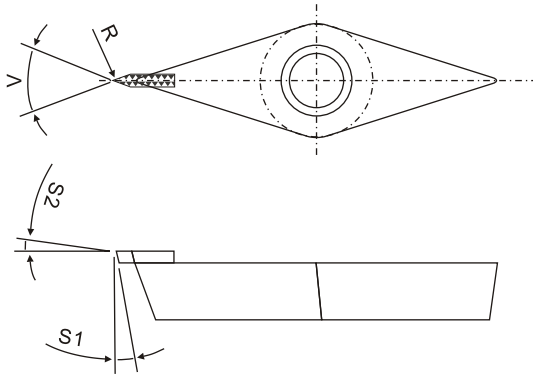

Cutting edge material

Synthetic monocrystalline diamond (MCD, MCC)

Features

1. Minimum cutter V-angle: 30°
2. Minimum nose radius: 0.01mm
3. Top of cutter shows no broken edge under 500x magnification
4. Special specifications available on customer order

Applications

1. PU roller groove machining
2. PE roller groove machining



Product Specification				
Specification	V-angle (V)	Nose Radius (R)	Front Clearance Angle (S1)	Back rake Angle (S2)
VCMW070200	35°	0.02	25°	5°
VCMW160400	35°	0.02	25°	5°
VCMW070200	45°	0.02	25°	5°
VCMW160400	45°	0.02	25°	5°
DCMW11T300	50°	0.02	25°	5°
DCMW070200	50°	0.02	25°	5°
DCMW11T300	60°	0.02	25°	5°
DCMW070200	60°	0.02	25°	5°
DCMW11T300	90°	0.02	25°	5°
DCMW070200	90°	0.02	25°	5°

06

Tools for automobile and motorcycle industry

Continuously growing automobile industry has long been a key segment of modern economy. It requires high quality, performance, efficiency and low costs production to be competitive. Emerging new product, technology and material demands improved machining technology and cutter. This company has been striving to meet customer needs of quality, speed, and efficiency with new cutter material, design, and process joint developed by the design, production, and service teams.



Cylinder body



Cylinder head



Gearbox valve body

Our specialty:

We have achieved comprehensive cutter design and development addressing automobile components processing and production configuration requirements. We provide professional solutions for the machining of main vehicle components including engine cylinder body, cylinder head, gearbox, piston, connecting rod, camshaft, crankshaft, brake disc, gear, and compressor.

Our capacity:

This company has been investing in design, development, and production of precision cutters along with manufacturing facility, machine equipment and R&D team to make high quality and reliability cutter based on development of high efficiency and performance cutter. In addition to our best efforts in promoting the growth of the automobile industry, we aid by our parent company, the Asahi Diamond Industrial Co., Ltd. (Japan) to provide total solutions for automobile components machining.



Camshaft



Crankshaft



Piston



Connecting rod

07

Tools for woodworking industry

1.PCD board cutter for system furniture

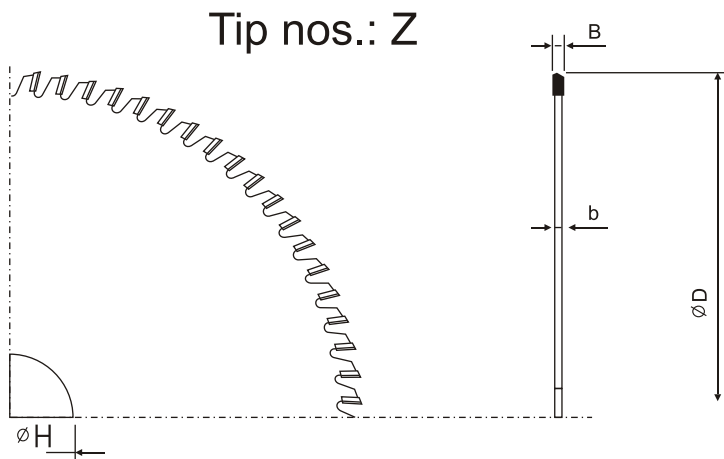

PCD Board Cutter Dimension				unit: mm
O.D. (ØD)	Tip Thickness (B)	Core Thickness (b)	Center Hole (H)	Tip nos. (Z)
85	3.8	2.2/2.8/3.0	20/22/30	16/20
100	3.8	2.8/3.0	30	20
120	3.8	2.8/3.0	30	20
150	3.8	2.8/3.0	30	30
170	4	3	40	30
170	5	4	40	16
180	3.8	2.2/2.8/3.0	40	20/30
180	4.4/5.5	3.2	45	36
227	3.7	3.2	25.4/30	40
260	4	3.0/3.2	25.4/30	60
305	4	3.0/3.2	25.4/30	60
355	4	3.2	25.4/30	72
367	4	3.2	25.4/30	78

2.PCD trimmer for system furniture



Equipment Name	CNC Machine Tool
Cutter Usage	Trimming
Cutter Specification	125D-64T-30H-18S
Cutter Core	Tool steel
Speed	12,000RPM

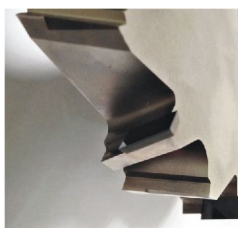

Equipment Name	CNC Machine Tool
Cutter Usage	Trimming
Cutter Specification	170D-18T-40H-12S
Cutter Core	Tool steel
Speed	12,000RPM



Equipment Name	CNC Machine Tool
Cutter Usage	Trimming
Cutter Specification	170D-18T-40H-12S(PCD) +12S(TC)
Cutter Core	Tool steel
Speed	12,000RPM



Equipment Name	CNC Machine Tool
Cutter Usage	Trimming
Cutter Specification	16D-16B-(5~8)S-70L
Cutter Core	Tool steel
Speed	12,000RPM

3.PCD chamfer tool for system furniture

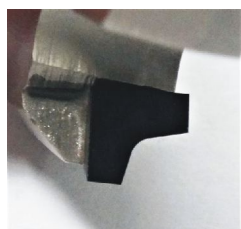
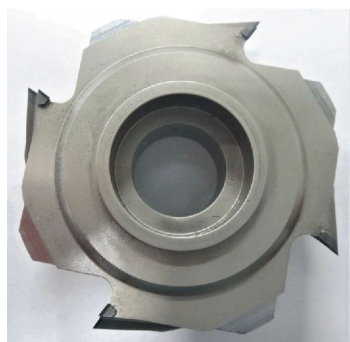

Equipment Name	CNC Machine Tool
Cutter Usage	Chamfer
Cutter Specification	67.2D-23T-18.1H-4S
Cutter Core	Tool steel
Speed	24,000RPM



Equipment Name	CNC Machine Tool
Cutter Usage	Chamfer
Cutter Specification	70D-23T-18.1H-4S
Cutter Core	Tool steel
Speed	24,000RPM



Equipment Name	CNC Machine Tool
Cutter Usage	Chamfer
Cutter Specification	76.1D-23T-18.1H-4S
Cutter Core	Tool steel
Speed	24,000RPM

08

CVD drill for composite material machining

For the machining of carbon fiber reinforced plastics (CFRP) and fiber glass for the aerospace industry.

Diameter (\varnothing D) INCH(mm)	Cutter Edge Length (L1)(INCH)	Total Length (L) (INCH)
0.1285 (3.264)	1.50	3.00
0.1320 (3.353)	1.50	3.00
0.1562 (3.967)	1.50	3.00
0.1630 (4.140)	1.50	3.00
0.1860 (4.724)	2.00	6.00
0.1875 (4.763)	2.00	6.00
0.1890 (4.800)	2.00	6.00
0.1910 (4.851)	2.00	6.00
0.2180 (5.537)	2.00	6.00
0.2240 (5.689)	2.00	6.00
0.2300 (5.842)	2.00	6.00
0.2344 (5.954)	2.00	6.00
0.2500 (6.350)	2.00	6.00
0.2510 (6.375)	2.00	6.00
0.2515 (6.388)	2.00	6.00
0.2550 (6.477)	2.00	6.00
0.2570 (6.528)	2.00	6.00
0.2810 (7.137)	2.00	6.00
0.2960 (7.518)	2.00	6.00
0.3125(7.938)	2.00	6.00
0.3195 (8.115)	2.00	6.00
0.3750 (9.525)	2.00	6.00
0.3850 (9.779)	2.00	6.00
0.5000 (12.70)	2.00	6.00
0.5610 (14.249)	2.00	6.00

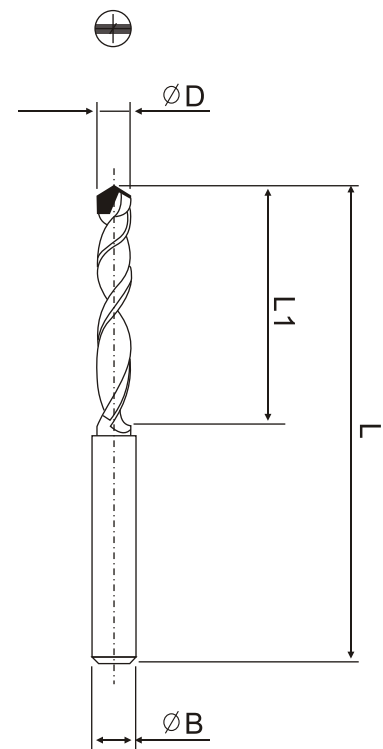
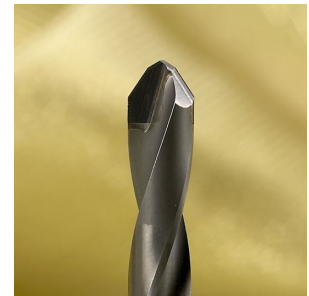

Accuracy :
 Outer diameter runout: Max. 5 μ m
 Outer diameter tolerance
 accuracy: ± 0.010 mm

09

PCD/PCBN end mill for precision mold machining

Usage :

- (1) Precision molds for 3C industry, micro dimension components. (e.g. cellphone casing, game machine controller)
- (2) Precision molds for optoelectronics, LED, optical lens industry.
- (3) Car lamp mold.
- (4) Other precision mold.



Features :

- (1) CPBN is ideal for machining hard to cut material, e.g., steel of hardness HRC60 or greater
- (2) Excellent wear resistance and good machining surface
- (3) Faster feeding speed and tripled or even more service life relative to tungsten carbide cutter
- (4) Ball nose end mill with R angle accuracy up to $\pm 5 \mu m$

1. Ball nose end mill

A. PCBN micro diameter ball nose end mill

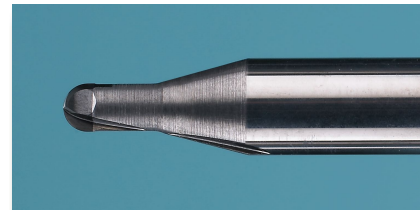
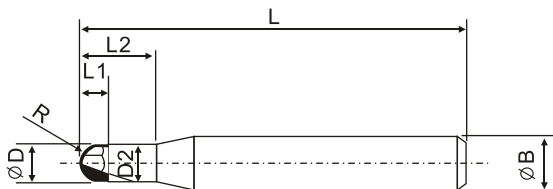

ØD	ØD2	L1	L2	L	R	ØB	Z (cutting edge nos.)
0.6	0.55	0.5	1.5	50	0.3	4	2
0.8	0.75	0.6	2.0	50	0.4	4	2
1	0.95	0.7	2.5	50	0.5	4	2
1.2	1.15	0.8	3.0	50	0.6	4	2
1.4	1.35	1	3.5	50	0.7	4	2
1.5	1.45	1	3.8	50	0.75	4	2
1.6	1.55	1	4.0	50	0.8	4	2
1.8	1.75	1	4.0	50	0.9	4	2
2	1.95	1.2	5.0	50	1	4	2

B.PCD/PCBN ball nose end mill

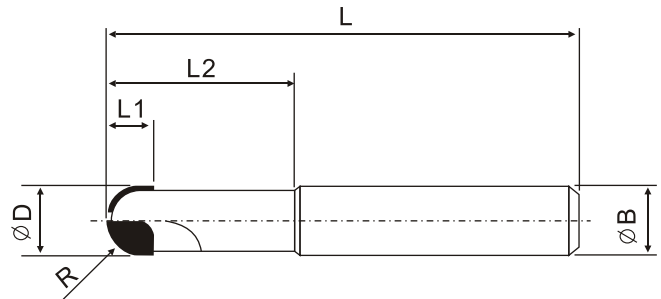

$\varnothing D$	$\varnothing D_2$	L_1	L_2	$\varnothing B$	L	R	Z (cutting edge nos.)
3	2.8	2.5	9	6	75	1.5	1
3	2.8	2.5	15	6	75	1.5	1
3	2.8	2.5	21	6	75	1.5	1
4	3.8	2.5	12	6	75	2	1
4	3.8	2.5	20	6	75	2	1
4	3.8	2.5	28	6	75	2	1
5	4.6	3.0	15	6	75	2.5	2
5	4.6	3.0	25	6	75	2.5	2
5	4.6	3.0	35	6	75	2.5	2
6	5.5	6.0	18	6	100	3.0	2
6	5.5	6.0	30	6	100	3.0	2
6	5.5	6.0	42	6	100	3.0	2
6	5.9	6.0	60	6	100	3.0	2
8	7.4	7.0	24	8	100	4.0	2
8	7.4	7.0	40	8	100	4.0	2
8	7.8	8.0	60	8	100	4.0	2
10	9.2	8.0	30	10	100	5.0	2
10	9.2	8.0	50	10	100	5.0	2
10	9.8	10.0	60	10	105	5.0	2
12	11.2	9.0	36	12	105	6.0	2
12	11.2	9.0	60	12	105	6.0	2

2. Corner Radius end mill

A.PCBN micro diameter corner radius end mill

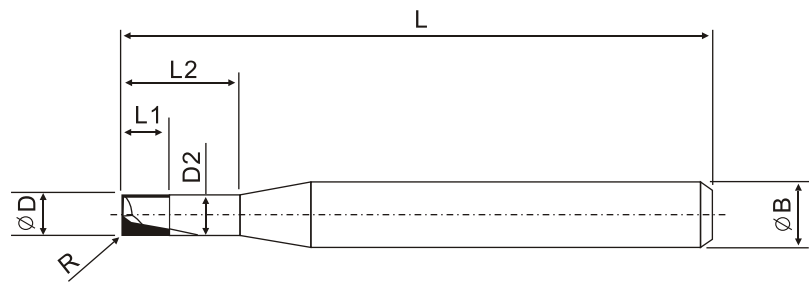
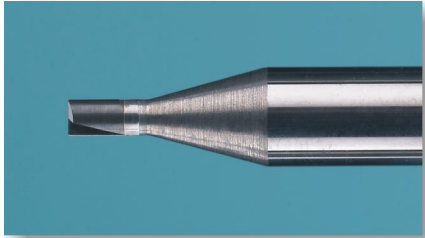

ØD	ØD2	L1	L2	L	R	ØB	Z(cutting edge nos.)
0.6	0.55	0.5	1.5	50	0.03~0.05	4	2
0.8	0.75	0.6	2.0	50		4	2
1	0.95	0.7	2.5	50		4	2
1.2	1.15	0.8	3.0	50		4	2
1.4	1.35	1	3.5	50		4	2
1.5	1.45	1	3.8	50		4	2
1.6	1.55	1	4.0	50		4	2
1.8	1.75	1	4.0	50		4	2
2	1.95	1.2	5.0	50		4	2

B.PCD/PCBN corner radius end mill

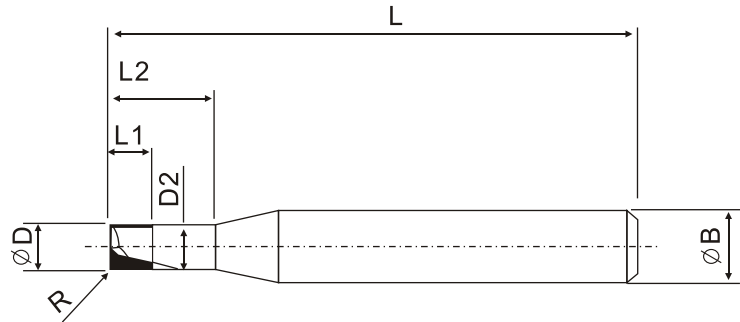

ØD	ØD2	L1	L2	ØB	L	R	Z (cutting edge nos.)
3	2.8	2.5	9	6	75	Customized	1
3	2.8	2.5	15	6	75		1
3	2.8	2.5	21	6	75		1
4	3.8	2.5	12	6	75		1
4	3.8	2.5	20	6	75		1
4	3.8	2.5	28	6	75		1
5	4.6	3.0	15	6	75		2
5	4.6	3.0	25	6	75		2
5	4.6	3.0	35	6	75		2
6	5.5	6.0	18	6	100		2
6	5.5	6.0	30	6	100		2
6	5.5	6.0	42	6	100		2
6	5.9	6.0	60	6	100		2
8	7.4	7.0	24	8	100		2
8	7.4	7.0	40	8	100		2
8	7.8	8.0	60	8	100		2
10	9.2	8.0	30	10	100		2
10	9.2	8.0	50	10	100		2
10	9.8	10.0	60	10	105		2
12	11.2	9.0	36	12	105		2
12	11.2	9.0	60	12	105	2	

10

Wear-resistant parts

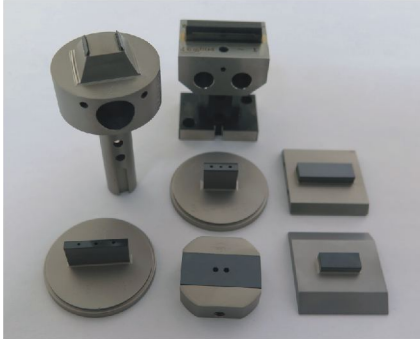

Wear-resistant tool for packaging



Wear-resistant workpiece for instrument



Wear-resistant workpiece for machine



Wear-resistant workpiece for micro drill machining



Wear-resistant workpiece for bearing industry

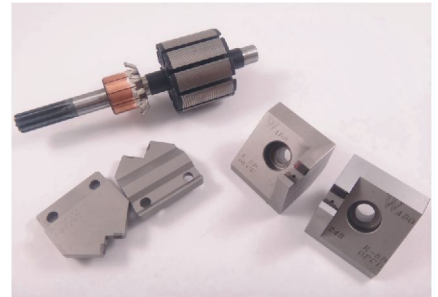

Wear-resistant workpiece for motor commutator



PCD thimble



ND measurement terminal



PCD measurement terminal



MCD wear-resistant workpiece for WEDM wire



PCD wear-resistant workpiece



PCD wire cutter for textile industry

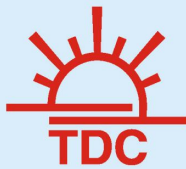

www.taiwandiamond.com

HEAD OFFICE : No.248,Hwakong St., Padeh Dist., Taoyuan City, Taiwan

TEL : +886-3-3636971 FAX: +886-3-3620709

E-mail : sales@taiwandiamond.com

TAIPEI OFFICE : TEL : +886-2-85212840 FAX : +886-2-85212845

HSINCHU OFFICE : TEL : +886-3-5775955 FAX : +886-3-5774789

TAICHUNG OFFICE : TEL : +886-4-24253019 FAX : +886-4-24253026

TAINAN OFFICE : TEL : +886-6-2797481 FAX : +886-6-2797474

KAOHSIUNG OFFICE : TEL : +886-7-5567581 FAX : +886-7-5567590

HUALIEN OFFICE : TEL : +886-3-8327196 FAX : +886-3-8362800

SHANGHAI OFFICE : TEL : +86-21-22096188 FAX : +86-21-62270531



2017.08(1000)