

HYDROKOMP®

Hydraulische Komponenten GmbH
Technology that connects

Clamping Elements

500 bar / 70 bar



versatile

reliable

durable



Innovative clamping technology made easy



Description:

Hydraulic threaded body cylinders are integrated directly into the fixture body to save space. The threaded body cylinder, due to its compact design, does not have an internal stop for the return stroke, rather it uses the bottom of the assembly bore. Cylinder sealing is done using O-rings and support rings. Oil supply is done in the fixture body via drilled channels.

The threaded body cylinder is fitted with a soft and/or metal wiper depending on the design. The soft wiper reduces dynamic leaks. In addition, the metal wiper prevents shavings from penetrating into the soft wiper and thereby damaging the piston rod surface. This preventative measure protects the seals from damage and increases the operating availability of the threaded body cylinder.

Threaded body cylinder with internal stroke limits can also be actuated without a counter-clamp surface.

Portfolio:

double-acting:

The double-acting function permits cycle linked strokes during cylinder extension and retraction. Extension and retraction strokes are force-actuated.

single-acting:

This function permits clear extension times. The piston is retracted to the depressurised start position by an integrated return spring.

HYDROKOMP offers the threaded body cylinder in a catalogued standard range and as customer-specific custom variants.

Standard range:

- EZY with metal wiper Page 3
- EZY with stroke limiter Page 3
- EZY with spring reset Page 4
- EZY with soft wiper Page 4

Threaded body cylinder in practical use:

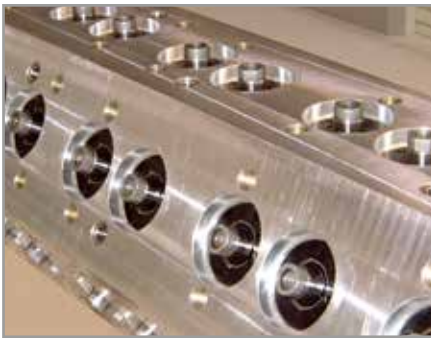

Multiple rotary clamping fixture

A controlled rotation is installed in the counter-bearing of this clamping fixture so that only the upper facing fixture side can be clamped or released. The function of this rotating connection is based on the principle of a rotary disc.

Hydraulic threaded body cylinders are designed as single-acting tension pull cylinders and are integrated into the fixture body. The pressure oil supply is done within the fixture and only via the drilled oil channels.

With this design, it is possible to supply the fixture with continuous pressure and only the sixth, upwards facing side can be clamped or released. The hydraulic rotary clamping fixture offers enormous economical advantages during processing of rotating workpieces in series manufacture. These are:

- Multi-side workpiece processing
- High clamping security and quality
- Reduction in tool change times
- Increase in machine runtime
- Reduction of workpiece change times

Integrated threaded body cylinder:
EZY with metal wiper (custom variant)

Multiple clamping fixture:

Use in a multiple clamping fixture for series manufacture of different workpieces (e.g. flange plates).

The fixture is located on a rotary table. The clamping length is 600 mm.

48 single acting threaded body cylinders with a piston diameter of 20mm and a stroke of 15mm are used, and a controlled rotation, single acting with 6 stations with a nominal width of 5.

Integrated threaded body cylinder:
EZY with spring reset



EZY with metal wiper

⊗ Operating pressure:	pmax. 500 bar
⊗ Operating method:	double-acting
⊗ Piston Ø:	16, 20, 25, 32, 40 and 50 mm
⊗ Stroke:	16, 20, 25, 32, 50, 100 and 160 mm
⊗ Pushing force:	from 2 kN (100 bar) up to 98,5 kN (500 bar)
⊗ Pulling force:	from 1,22 kN (100 bar) up to 57,9 kN (500 bar)
⊗ Oil connection:	drilled channels
⊗ Seal type:	NBR -10°C to +80°C, FKM to 150°C
⊗ Wiper:	soft wiper and metal wiper
⊗ Characteristics:	- fully immersible housing
	- use of pressure screws possible
	- mounting plate available as an accessory

Data sheet: 200-2

Webcode: 020002

Mounting plate (accessory):

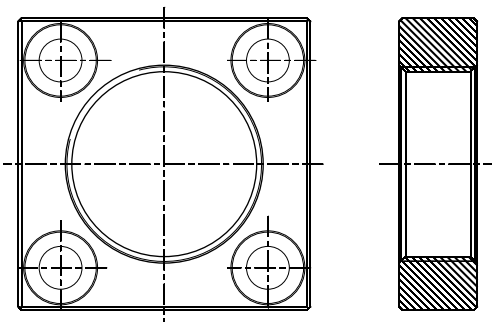

Integration contour:

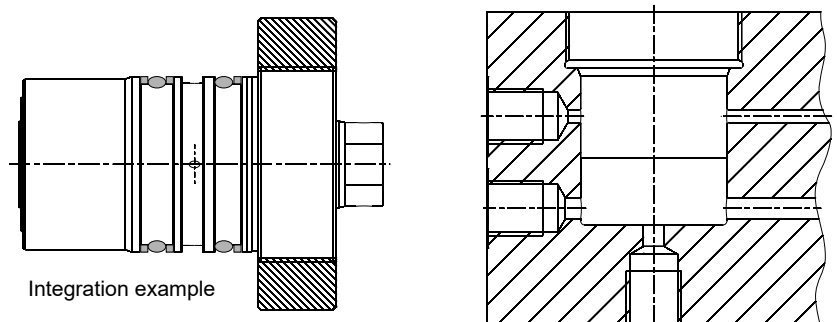

EZY with stroke limiter

⊗ Operating pressure:	pmax. 500 bar
⊗ Operating method:	single acting with spring reset
⊗ Piston Ø:	20, 25 and 32 mm
⊗ Pushing force:	4 and 8 mm
⊗ Pulling force:	from 3,1 kN (100 bar) up to 40,2 kN (500 bar)
⊗ Oil connection:	drilled channels
⊗ Seal type:	NBR -10°C to +80°C, FKM to 150°C
⊗ Wiper:	with/without soft wiper
⊗ Characteristics:	- usable as a clamping or tensioning cylinder
	- can also be implemented without
	a counter-clamp surface
	- large rounded piston surface

Data sheet: 210-1

Webcode: 021001



EZY with spring reset

⊗ Operating pressure:	pmax. 400 bar
⊗ Operating method:	single-acting with spring reset
⊗ Piston Ø:	12, 16, 20, 25 and 32 mm
⊗ Stroke:	10, 12, 15, 16 and 20 mm
⊗ Pushing force:	from 1,1 kN (100 bar) up to 32 kN (400 bar)
⊗ Pulling force:	from 30 N up to 200 N
⊗ Oil connection:	drilled channels
⊗ Seal type:	NBR -10°C to +80°C, FKM to 150°C
⊗ Wiper:	without/with double wiper
⊗ Characteristics:	- can also be fully loaded when retracted
	- does not require a venting connection
	- variable with different designs

Data sheet:

210-2

Webcode:

021002

Design 1:

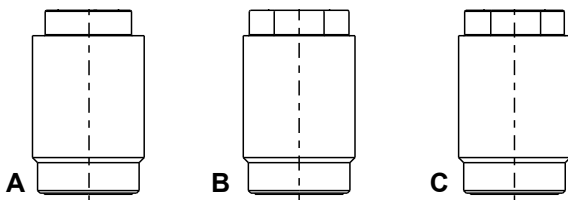

Threaded body cylinder with spring reset without double wiper

Design 2:

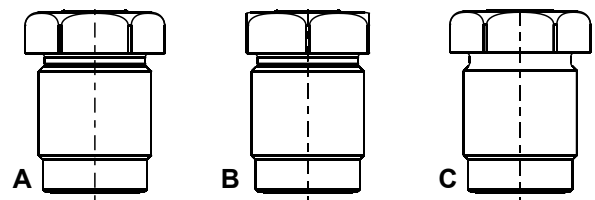

Threaded body cylinder with spring reset and double wiper



EZY with soft wiper

⊗ Operating pressure:	pmax. 500 bar
⊗ Operating method:	single-acting with spring reset
⊗ Piston Ø:	8, 12, 16, 25 and 32 mm
⊗ Stroke:	4, 6, 12 and 16 mm
⊗ Pushing force:	from 0,5 kN (100 bar) up to 40 kN (500 bar)
⊗ Pulling force:	from 25 N up to 183 N
⊗ Oil connection:	drilled channels
⊗ Seal type:	NBR -10°C to +80°C, FKM to 150°C
⊗ Wiper:	soft wiper
⊗ Characteristics:	- rounded piston surface
	- seal with a metallic sealing rim
	- optimum for high clamping forces and force sealing

Data sheet:

210-3

Webcode:

021003



Description:

Block cylinders are popular design elements in all areas where short strokes with high force are required. You have a piston rod thread that is either internal or external depending on the design. For example, pressure screws can be securely screwed into an interior thread and thread pivoting heads can be mounted on the exterior thread.

The compact cubic design of the block cylinder makes cylinder fastening easier and guarantees high operating pressures. Different variants of the pressure oil supply cover the spectrum of applications.

A double hydraulic seal is used as standard in our block cylinder, which guarantees an extreme leak-tight continuous operation. All block cylinders are additionally fitted with a metal wiper, which prevents penetration of metal shavings into the soft wiper and this significantly increases the operating availability of the block cylinder.

Portfolio:

HYDROKOMP offers the block cylinder in a catalogued standard range and as customer-specific custom variants.

double-acting:

The double-acting function permits precise stroke times as the piston is extended and retracted. Extension and retraction strokes are force-actuated.

single-acting:

HYDROKOMP offers single-acting block cylinders with or without spring return. With a spring reset function the piston is pulled by the spring into the start position when depressured. Block cylinders without spring reset do not have an automatic piston return.

Standard range:

- BZY with internal piston thread Page 6
- BZY with external piston thread Page 6
- BZY with end position control (BZP1) Page 7
- BZY as pull cylinder (ZZY) Page 7

Designs:

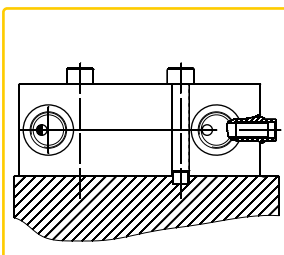

Type A

Oil supply via thread
G1/4 and G1/2

Mounting bores
in the housing:
lengthwise and
crosswise

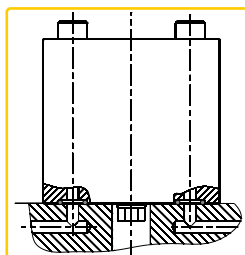

Type C

Oil connection
manifold with O-ring,
rod side

Mounting bores
in the housing:
lengthwise

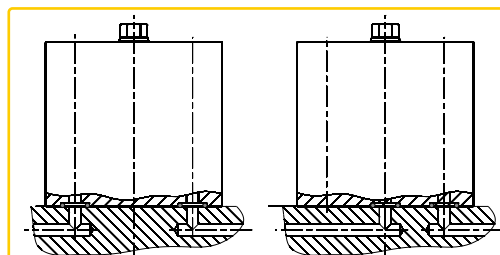

Type D

Oil connection
manifold with O-ring, bottom side
Fig. left variant 1 "Standard",
Fig. right variant 2 "Centre"

Mounting bores in the housing:
lengthwise

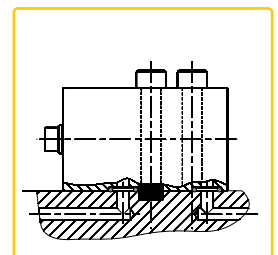

Type E

Oil connection
manifold with
O-ring

Mounting bores
in the housing:
crosswise

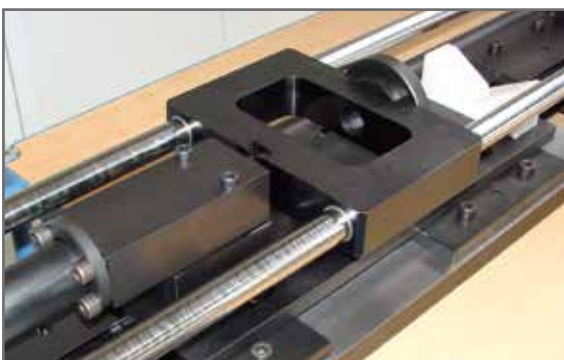

Practical example:

Press fit fixture

The figure shows a press fit fixture where bearings are pressed onto shafts. The block cylinder used has a stroke of 100 mm in order to bridge any spaces. Due to the range of workpieces, the carriage can be fitted appropriately with the block cylinder. Different support lengths are mounted axially behind the block cylinder for this purpose. This flexible solution means that very low bending forces are introduced into the total design.

A special feature of the fixture is the pressure reduction of the manual pressure generator. After pre-mounting the bearing, it is mechanically secured under pre-tension. For this, the mounting pressure is set to approx. 60 bars via a manual ball valve and is discharged downstream via a pressure limiting valve.

Integrated block cylinder:

BZY with interior piston thread



BZY with interior piston thread

⊗ Operating pressure:	pmax. 500 bar
⊗ Operating method:	single-acting / double-acting
⊗ Piston Ø:	16, 20, 25, 32, 40, 50, 63, 80 and 100 mm
⊗ Stroke:	numerous strokes from 8 to 200 mm
⊗ Extraction force:	from 2 kN (100 bar) up to 392 kN (500 bar)
⊗ Retraction force:	from 1,2 kN (100 bar) up to 23 kN (500 bar)
⊗ Oil connection:	- thread G1/4 and G1/2
⊗ Sealing:	- manifold with O-ring
⊗ Wiper:	NBR -10°C to +80°C, FKM to 150°C
⊗ Characteristics:	soft wiper and metal wiper
	- interior piston thread for accessories
	- ideal for leak-tight continuous operation
Data sheet:	200-3
Webcode:	020003



BZY with exterior piston thread

⊗ Operating pressure:	pmax. 500 bar
⊗ Operating method:	double-acting
⊗ Piston Ø:	25, 32, 40, 50 and 63 mm
⊗ Stroke:	50 and 63 mm
⊗ Extraction force:	from 4,9 kN (100 bar) up to 156 kN (500 bar)
⊗ Retraction force:	from 2,9 kN (100 bar) up to 93 kN (500 bar)
⊗ Oil connection:	- thread G1/4 and G1/2
	- manifold with O-ring
⊗ Seal type:	NBR -10°C to +80°C, FKM to 150°C
⊗ Wiper:	soft wiper and metal wiper
⊗ Characteristics:	- exterior piston thread for accessories
	- pivot head and bearing blocks can be purchased
Data sheet:	200-5
Webcode:	020005

Fastening elements (Accessories):

Joint heads

to screw onto the exterior thread of the piston rod



Bearing supports

for fastening onto the housing with 4 cylinder head screws (screws included in the scope)

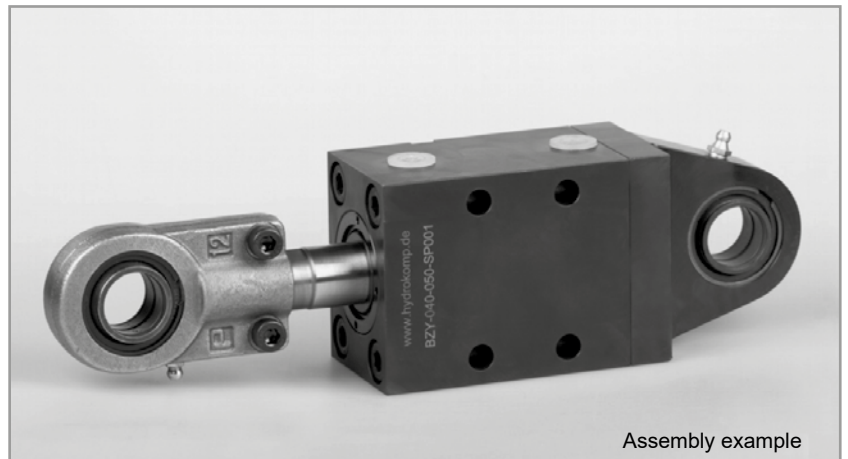

Assembly example



BZY with end position control (BZP1)

⊗ Operating pressure:	pmax. 500 bar
⊗ Operating method:	double-acting
⊗ Piston Ø:	16, 20, 25, 32, 40, 50, 63, 80 and 100 mm
⊗ Stroke:	numerous strokes from 16 to 160 mm
⊗ Pushing force:	from 2 kN (100 bar) up to 392 kN (500 bar)
⊗ Pulling force:	from 1,2 kN (100 bar) up to 237 kN (500 bar)
⊗ Oil connection:	- thread G1/4 and G1/2 - manifold with O-ring
⊗ Seal type:	FKM from -10°C up to 150°C
⊗ Wiper:	soft wiper and metal wiper
Characteristics:	- ideal for automated systems - high monitoring precision
Data sheet:	200-10
Webcode:	020010



Practical example:

Test fixture for coupling systems

HYDROKOMP developed the illustrated test fixture for coupling systems. Coupling mechanical plates to be tested are hydraulically connected on the lower fixture plate. The coupling nipple plates are fastened to the upper fixture plate. The block cylinder lowers the upper fixture plate and docks both systems together.

The cylinder piston docking process is monitored by inductive sensors. Only after the piston has been completely extended and the coupling process completed, is the system placed under pressure and checked for functionality.

Integrated block cylinder:
BZY with end position control (BZP1)



BZY as pull cylinder (ZZY)

⊗ Operating pressure:	pmax. 500 bar
⊗ Operating method:	single-acting with spring reset
⊗ Piston Ø:	16, 20, 25, 32, 40, 50, 63, 80 and 100 mm
⊗ Stroke:	8, 10 and 12 mm
⊗ Pushing force:	from 1,1 kN (100 bar) up to 235 kN (500 bar)
⊗ Pulling force:	from 40 N up to 1200 N
⊗ Oil connection:	- thread G1/4 and G1/2 - manifold with O-ring
⊗ Seal type:	NBR -10°C to +80°C, FKM to 150°C
⊗ Wiper:	soft wiper and metal wiper
⊗ Characteristics:	- A venting line can be connected - ideal for small non-sequenced systems
Data sheet:	200-6
Webcode:	020006



Description:

Functional principle:

Hydraulic swing pivot clamp cylinders release the workpiece clamping area when de-clamping. This makes workpiece exchange much easier. Swing clamp cylinders work single-acting with spring reset or double-acting, depending on design. The functional principle is similar to a pull cylinder where a part of the stroke is used to swing the piston.

Swing angle:

Right or left swing variants can be selected with different standard swing angles 0°, 30°, 45°, 60° or 90° can be supplied. The variant with a swing angle of 0° functions as a pure pull cylinder. Variants with other swing angles are offered as custom variants.

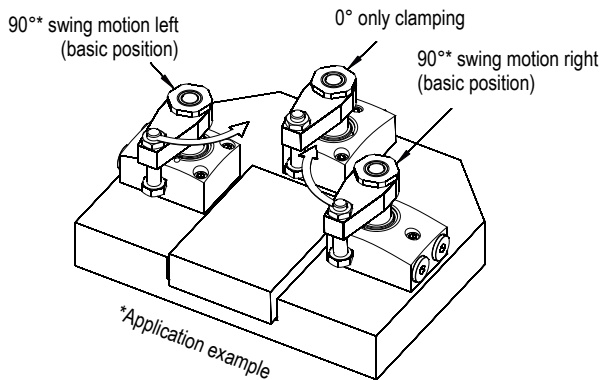

Position control:

Swing clamp cylinders can be supplied with electrical or pneumatic position control, variant dependent. Position control monitors the clamped and unclamped position of the cylinder. Position controls are available as accessories.

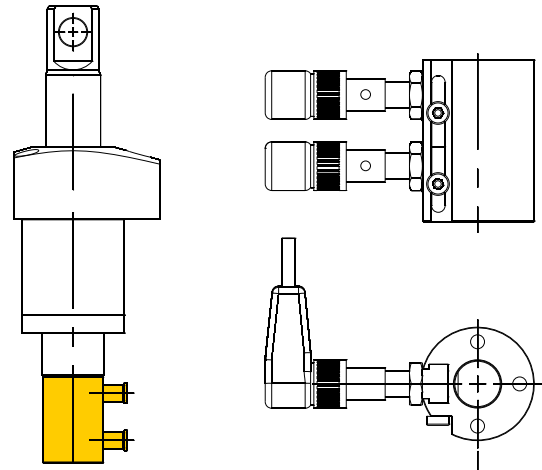

Pressure oil supply:

Swing clamp cylinders are fitted with pipe threads or manifold connections with O-ring for bored channels for pressure oil supply.

Protecting metal wiper:

All swing clamp cylinders up to compact clamping have an additional integrated metal wiper as standard. This prevents penetration of metal shavings into the soft wiper and thereby increases the operating availability of the swing clamp cylinder.

Clamp arm holder:

Piston rods can be purchased with forked head, tapered fixture 1:10 or pendulum eye to accept the clamp arm. In addition to the clamp arm from our catalogue range, customer specific custom clamp arms can be mounted.

Housing design:

There are different installation options for the swing clamp cylinder depending on the design type. In the first instance, these are dependent on the housing design and the connection options for oil supply

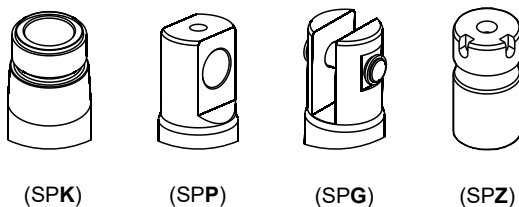

SPK= Taperaufnahme
SPP= Pendelauge
SPG= Gabelkopf
SPZ= Zylinderaufnahme

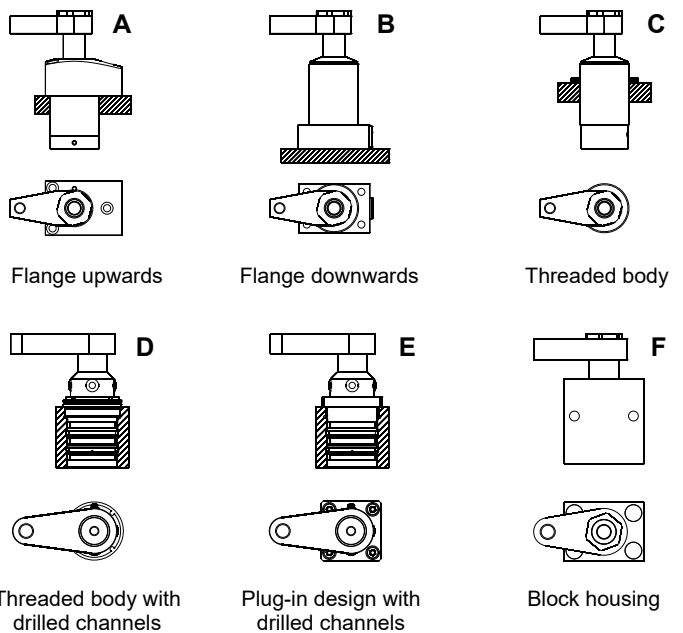

Overload protection:

Depending on the design, the swing clamp cylinder is fitted with an integrated overload protection. This protects the swing mechanics from damage, e.g. by blocking the swing process during operation or if the clamp arm was mounted improperly.

HYDROKOMP offers the swing clamp cylinders in a standard range and as customer-specific custom variants.



SSZY compact with flange and thread

⊗	Swing motion:	neutral / left / right
⊗	Operating method:	single-acting / double-acting
⊗	Swing angle:	0° / 45° / 60° / 90°
⊗	Housing design:	A = upper flange
⊗	Piston Ø:	14 mm
⊗	Clamping stroke:	sa. 6 mm / da. 8 mm
⊗	Clamp arm holder:	taper, ratio 1:10
⊗	Overload protection:	without
⊗	Position control:	without
⊗	Oil supply:	pipe thread / manifold with O-rings
⊗	Operating pressure:	pmin. 25 bar / pmax. 350 bar
Data sheet:		240-1
Webcode:		024001



SSZY compact with flange and thread

⊗	Swing motion:	neutral / left / right
⊗	Operating method:	single-acting / double-acting
⊗	Swing angle:	0° / 45° / 60° / 90°
⊗	Housing design:	B = lower flange
⊗	Piston Ø:	14 mm
⊗	Clamping stroke:	sa. 6 mm / da. 8 mm
⊗	Clamp arm holder:	taper, ratio 1:10
⊗	Overload protection:	without
⊗	Position control:	without
⊗	Oil supply:	pipe thread / manifold with O-ring
⊗	Operating pressure:	pmin. 25 bar / pmax. 350 bar
Data sheet:		240-2
Webcode:		024002



SSZY compact with threaded body

⊗	Swing motion:	neutral / left / right
⊗	Operating method:	single-acting / double-acting
⊗	Swing angle:	0° / 45° / 60° / 90°
⊗	Housing design:	D = Einschraubgewinde
⊗	Piston Ø:	14 mm
⊗	Clamping stroke:	ew. 6 mm / dw. 8 mm
⊗	Clamp arm holder:	Kegelaufnahme
⊗	Overload protection:	ohne
⊗	Position control:	ohne
⊗	Oil supply:	gebohrte Kanäle
⊗	Operating pressure:	pmin. 25 bar / pmax. 350 bar
Data sheet:		240-3
Webcode:		024003



SSZY with upper flange

⊗	Swing motion:	neutral / left / right
⊗	Operating method:	single-acting / double-acting
⊗	Swing angle:	0° / 30° / 45° / 60° / 90°
⊗	Housing design:	A = upper flange
⊗	Piston Ø:	25 / 40 / 50 / 63 mm
⊗	Clamping stroke:	10, 13, 15, 25 or 50 mm
⊗	Clamp arm holder:	taper, ratio 1:10
⊗	Overload protection:	with
⊗	Position control:	without
⊗	Oil supply:	pipe thread / manifold with O-ring
⊗	Operating pressure:	pmin. 30 bar / pmax. 500 bar
Data sheet: 240-10		Webcode: 024010



SSZY with flange and position control

⊗	Swing motion:	neutral / left / right
⊗	Operating method:	double-acting
⊗	Swing angle:	0° / 30° / 45° / 60° / 90°
⊗	Housing design:	A = upper flange
⊗	Piston Ø:	25 or 40 mm
⊗	Clamping stroke:	25 or 22 mm
⊗	Clamp arm holder:	clevis / pendulum
⊗	Overload protection:	without / with reinforced swing mechanism
⊗	Position control:	without / inductive / pneumatic
⊗	Oil supply:	pipe thread / manifold with O-ring
⊗	Operating pressure:	pmin. 30 bar / pmax. 500 bar
Data sheet: 240-20		Webcode: 024020



SSZY with lower flange and thread

⊗	Swing motion:	neutral / left / right
⊗	Operating method:	single-acting / double-acting
⊗	Swing angle:	0° / 30° / 45° / 60° / 90°
⊗	Housing design:	B = lower flange, C = thread
⊗	Piston Ø:	25 / 40 / 50 / 63
⊗	Clamping stroke:	10, 13, 15, 25 or 50 mm
⊗	Clamp arm holder:	taper, ratio 1:10
⊗	Overload protection:	without / with
⊗	Position control:	without
⊗	Oil supply:	drilled channels
⊗	Operating pressure:	pmin. 30 bar / pmax. 500 bar
Data sheet: 240-30		Webcode: 024030



SSZY with block housing

✘	Swing motion:	neutral / left / right
✘	Operating method:	single-acting / double-acting
✘	Swing angle:	0° / 30° / 45° / 60° / 90°
✘	Housing design:	F = block housing
✘	Piston Ø:	25 / 40 / 63 mm
✘	Clamping stroke:	7, 8, or 11 mm
✘	Clamp arm holder:	taper
✘	Overload protection:	with
✘	Position control:	without
✘	Oil supply:	pipe thread / O-ring flange
✘	Operating pressure:	pmin. 30 bar / pmax. 500 bar
	Data sheet:	240-40
	Webcode:	024040



SSZY with threaded body housing

✘	Swing motion:	neutral / left / right
✘	Operating method:	single-acting / double-acting
✘	Swing angle:	0°, 30°, 45°, 60° and 90°
✘	Housing design:	D (threaded body with drilled channels)
✘	Piston Ø:	25, 40 and 63 mm
✘	Clamping stroke:	10, 13 and 14 mm
✘	Clamp arm holder:	taper
✘	Overload protection:	with
✘	Position control:	without
✘	Oil supply:	drilled channels
✘	Operating pressure:	pmin. 30 bar / pmax. 500 bar
	Data sheet:	240-50
	Webcode:	024050



SSZY cartridge design

✘	Swing motion:	neutral / left / right
✘	Operating method:	double-acting
✘	Swing angle:	0° / 30° / 45° / 60° / 90°
✘	Housing design:	E = cartridge design
✘	Piston Ø:	25 / 40 / 50 / 63 mm
✘	Clamping stroke:	11, 14, 15 or 25 mm
✘	Clamp arm holder:	taper
✘	Overload protection:	with
✘	Position control:	without
✘	Oil supply:	drilled channels
✘	Operating pressure:	pmin. 30 bar / pmax. 500 bar
	Data sheet:	240-60
	Webcode:	024060



SSZY for low pressure range

✘	Swing motion:	neutral / left / right
✘	Operating method:	double-acting
✘	Swing angle:	0° / 30° / 45° / 60° / 90°
✘	Housing design:	A = upper flange
✘	Piston Ø:	37 / 44 or 51 mm
✘	Clamping stroke:	8 or 10 mm
✘	Clamp arm holder:	cylindrical holder
✘	Overload protection:	without
✘	Position control:	without
✘	Oil supply:	pipe thread / manifold with O-ring
✘	Operating pressure:	pmin. 15 bar / pmax. 70 bar

Data sheet: 240-70 **Webcode:** 024070

Lever clamp cylinders (HSZY)

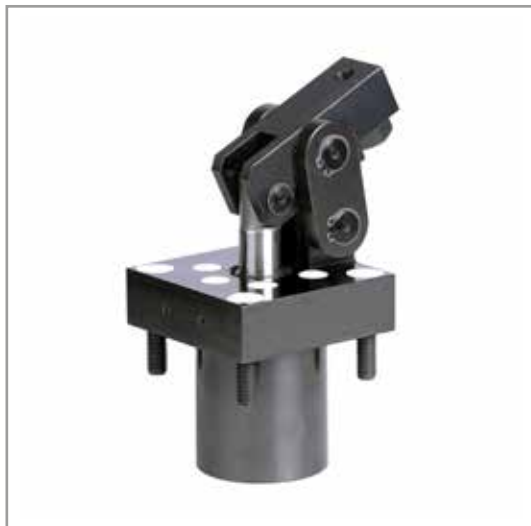

HSZY without/with position controle

✘	Operating pressure:	pmax. 350 bar (200 bar at piston Ø 40 mm)
✘	Operating method:	double-acting
✘	Piston Ø:	16, 25 and 40 mm
✘	Clamping force:	from 1,5 kN (100 bar) up to 19 kN (pmax.)
✘	Oil supply:	- threaded port G1/8 or G1/4 - manifold with O-ring - drilled channels
✘	Sealing:	FKM from -10°C up to 150°C
✘	Wiper:	soft wiper and metal wiper
✘	Position control:	accessory

Data sheet: 250-1 **Webcode:** 025001

Description:

Lever clamping cylinders are primarily for uses where the clamping location for workpiece handling shall be free after de-clamping. The advantage compared to swing clamp cylinders is in its compact design and a high clamping force.

The lever clamp cylinder is specifically for uses where contours interfere, meaning swing clamp cylinders cannot be used.

The high force density is guided via a pressure piston into the clamping lever. The moving bearing of the clamping lever releases the clamping point when unclamping. Hydraulic lever clamp cylinders are double-acting. This gives clear opening and closing times.

The lever clamp cylinder can be fitted with a continuous piston rod. This permits use of a position control (accessory) to monitor the piston location. Query of position can be done via inductive proximity switch or pneumatically.

Types of connection:

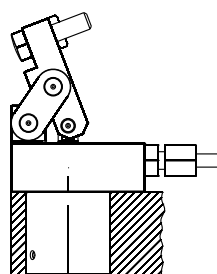

Type A
Plug-in design,
oil supply via thread
G1/8 and G1/4

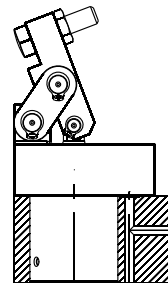

Type B
Plug-in design,
oil supply manifold
with O-ring

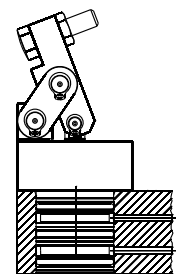

Type C
Plug-in design,
oil supply via
drilled channels



Built-in pistons with threaded bushing

⊗ Operating pressure:	pmax. 500 bar
⊗ Operating method:	double-acting
⊗ Piston Ø:	16, 20, 25, 32, 40, 50, 63, 80 and 100 mm
⊗ Stroke:	numerous strokes from 16 to 160 mm
⊗ Pushing force:	from 2 kN (100 bar) up to 392 kN (500 bar)
⊗ Oil connection:	drilled channels
⊗ Seal type:	NBR -10°C to +80°C, FKM to 150°C
⊗ Wiper:	soft wiper and metal wiper
⊗ Characteristics:	- space saving integrated option - directly into the fixture body of the fixture - interior piston thread for accessories
Data sheet::	200-4
Webcode:	020004



Universal cylinders SA

⊗ Operating pressure:	pmax. 500 bar (piston Ø 50 mm 400 bar)
⊗ Operating method:	single-acting
⊗ Piston Ø:	10, 25, 40 and 50 mm
⊗ Stroke:	20, 22 and 50 mm
⊗ Pushing force:	from 0,7 kN (100 bar) to 78 kN (500 bar)
⊗ Reset force:	from 28 N up to 390 N
⊗ Oil connection:	thread G1/4
⊗ Seal type:	NBR -10°C to +80°C
⊗ Wiper:	soft wiper and metal wiper
⊗ Characteristics:	- integrated depth adjustable in 10 mm increments - suitable for changing workpiece sizes
Data sheet::	220-2
Webcode:	020002



Universal cylinders DA

⊗ Operating pressure:	pmax. 500 bar
⊗ Operating method:	double-acting
⊗ Piston Ø:	25, 32, 40, 50 and 63 mm
⊗ Stroke:	32, 40, 50 and 64 mm
⊗ Pushing force:	from 4,9 kN (100 bar) up to 124,4 kN (500 bar)
⊗ Pulling force:	from 3,3 kN (100 bar) up to 84 kN (500 bar)
⊗ Oil connection:	thread G1/4 and G 3/8
⊗ Seal type:	NBR -10°C up to +80°C
⊗ Wiper:	soft wiper
⊗ Characteristics:	- integrated depth adjustable in 2 mm increments - thread connections axial and radial
Data sheet:	220-3
Webcode:	022003



Hollow piston cylinders

⊗ Operating pressure:	pmax. 500 bar
⊗ Operating method:	single-acting / double-acting
⊗ Piston Ø:	20, 32, 40, 50, 63 and 80 mm
⊗ Stroke:	6, 8, 10, 12, 16, 20, 32 and 40 mm
⊗ Pushing force:	from 2 kN (100 bar) up to 153 kN (500 bar)
⊗ Pulling force:	from 2 kN (100 bar) up to 188,5 kN (500 bar)
⊗ Reset force:	from 90 N up to 950 N
⊗ Oil connection:	thread G1/4
⊗ Seal type:	NBR -10°C up to +80°C
⊗ Wiper:	soft wiper and metal wiper
⊗ Characteristics:	through drilled piston with thread
Data sheet:	220-6
Webcode:	022006



Work supports with threaded body

⊗ Operating pressure:	pmax. 500 bar
⊗ Operating method:	advance by spring or hydraulics
⊗ Plunger:	Ø 16 mm, stroke 8 mm
⊗ Support force:	max. 12 kN at 500 bar
⊗ Spring force min.:	8 N (spring) 10 N (hydraulics)
⊗ Spring force max.:	23 N (spring) 13 N (hydraulics)
⊗ Oil connection:	drilled channels
⊗ Wiper:	soft wiper and metal wiper
⊗ Characteristics:	- possibility to clamp separately or combined with the clamping process - horizontal and vertical integration possible
Data sheet:	280-1
Webcode:	028001



Work supports with threaded body and flange

⊗ Operating pressure:	pmax. 500 bar
⊗ Operating method:	advance via spring force (adjustable)
⊗ Plunger:	Ø 32 stroke 16 mm, 40 mm, Ø 40 stroke 18 mm
⊗ Support force:	max. 60 kN at 500 bar
⊗ Advance force:	from 40 N up to 100 N
⊗ Oil connection:	- thread G1/4 - manifold with O-ring
⊗ Wiper:	metal wiper
⊗ Characteristics:	- support bolts with interior thread - possibility to clamp separately or combined with the clamping process
Data sheet:	280-10
Webcode:	028010



Low-block clamping cylinders

✘ Operating pressure:	pmax. 500 bar
✘ Operating method:	single-acting with spring reset
✘ Piston Ø:	16, 25 and 36 mm
✘ Stroke:	8 and 10 mm
✘ Clamping force:	from 1,7 kN (100 bar) up to 40 kN (500 bar)
✘ Stroke limiter:	with
✘ Oil connection:	- thread G1/4 - manifold with O-ring
✘ Seal type:	NBR -10°C up to +80°C
✘ Characteristics:	guides the clamping force sideways into the workpiece
Data sheet:	230-1
Webcode:	023001



Locking cylinders

✘ Operating pressure:	pmax. 500 bar
✘ Operating method:	single-acting without spring reset
✘ Piston:	available with 1 piston or 2 pistons
✘ Stroke:	5 mm (1 piston), 2 mm (2 pistons)
✘ Clamping force:	from 4,9 kN (100 bar) up to 49 kN (500 bar)
✘ Oil connection:	thread G1/4
✘ Seal type:	NBR -10°C up to +80°C
✘ Characteristics:	- impact is done hydraulically - discharge by pressure reduction - clamping pressure monitoring possible
Data sheet:	230-2
Webcode:	023002



Rotary lever clamps

✘ Operating pressure:	pmax. 400 bar
✘ Operating method:	single-acting / double-acting
✘ Design:	for hydraulics or pneumatics
✘ Piston Ø:	12, 16, 20, 25, 32, 40 and 50 mm
✘ Clamping force:	from 1,1 kN (100 bar) up to 95 kN (400 bar)
✘ Oil connection:	- thread G1/8 and G1/4 - manifold with O-ring
✘ Characteristics:	- permits clamping without shear forces - housing can be lowered partially - clamping lever and housing blocks can be supplied
Data sheet:	250-10
Webcode:	025010

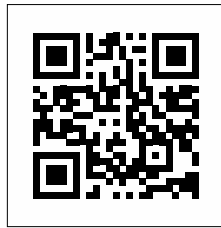

More than 1,000 products are available at www.hydrokomp.de

For customized modifications and special designs we will be pleased to support you.



HYDROKOMP
Hydraulische Komponenten GmbH



+49 6401 225999-0
+49 6401 225999-50



info@hydrokomp.de



Siemensstraße 16
35325 Mücke
(Germany)

