

鑽石油石 / Diamond Stones

■ 鑽石油石主要使用於各種刀具研磨後之刃部修磨，以延長刀具之壽命及提高加工物之表面光製度。此外，亦適用於鑄鋼、陶瓷及硬化後鋼料之表面研磨。

■ Diamond Stone is considered as final finish for cutting tools. It is used to refine a surface by removing scratch lines and other surface imperfections. Therefore prolong the tool's life and smooth a surface finish. Also apply to lap the tungsten, ceramics and hardened steels.

規格 / Specifications:

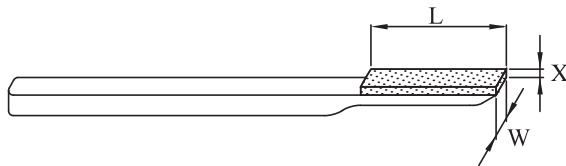

附柄型 / With shank

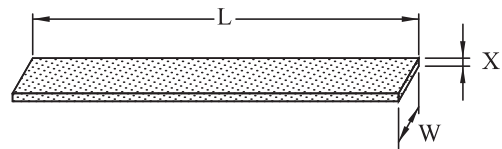

實心(無柄)型 / Solid (without shank)

單位 / Unit : mm

	尺寸/Dimensions W-(R)-X-L	柄部材質 Shank material	編號 Order no.
	10-2-40	塑膠柄 Plastic shank	RSH-01
	5-2-40	鐵柄 Steel shank	RSH-02
	5-2.5R-4-40	鐵柄 Steel shank	RSH-03
	10-2-30	鋁柄 Aluminum shank	RSH-04
	10-3-120	-	RS-04
	6-3-100	-	RS-05
	4-4-100	-	RS-06
	6-2-100	-	RS-08

Remark : 1. Grit size available : #200, #400, #600, #800, #1000, #1200, #1800, #2000, #3000, #5000.
2. When ordering, please specify order no. & grit size.

說明：1. 標準粒度：#200, #400, #600, #800, #1000, #1200, #1800, #2000, #3000, #5000。
2. 訂購時，敬請指名產品編號與所需粒度。



鑽石纖維油石 / Ceramic Diamond Stones

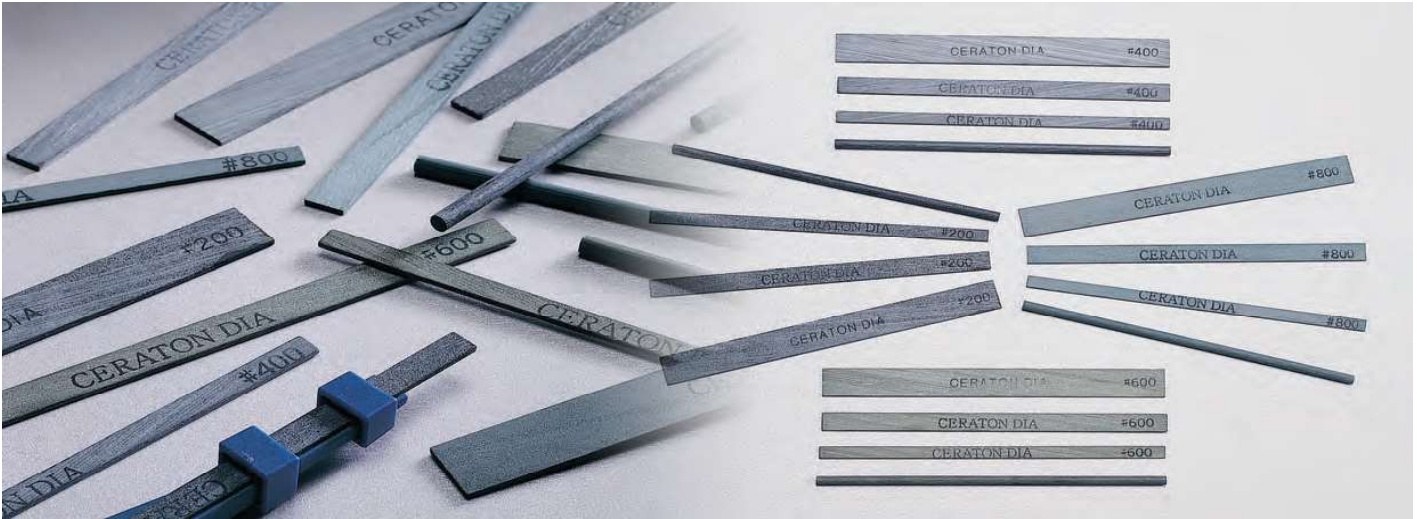

鑽石纖維油石是將鑽石磨料與陶瓷纖維以熱固型樹脂結合而成。由於鑽石優越的切削效果加上陶瓷纖維的高抗折強度，結合成一個完美的拋磨工具。鑽石磨料均勻地分布在陶瓷纖維上，使超級鑽石油石任何面均可研削且加工面很均勻，如此可以減少後續的加工作業時間。

特長：

1. 一般纖維油石只能用端面研削，而鑽石纖維油石任何面均有研磨效果。
2. 與樹脂鑽石油石比較，鑽石纖維油石有較佳的切削能力、不易塞目及不易折斷等優點。
3. 一些用一般纖維油石不易加工的材料，現在用鑽石纖維油石可以有效的切削。
4. 鑽石纖維油石適合使用於加工所有熱處理後的鋼材、碳化鎢、陶瓷及玻璃等。

Ceramic diamond stones are made of diamond abrasives and ceramic fibers bonded together with thermosetting resin. Thanks diamond for its outstanding cutting performance in combination with the superior tensile strength of ceramic fiber, generates ceramic diamond stone, a perfect lapping tool.

Diamond particles are sprayed on ceramic fibers for excellent uniform cutting action on every angle and therefore reduce after processing work.

Features :

1. The ordinary ceramic fiber stone is efficient only to lap its end side or edge, while the ceramic diamond stone works well with any sides.
2. In comparison to the resinous diamond stones, ceramic diamond stone is more aggressive in cutting rate, resist loading, and hardly broken.
3. Materials those are difficult to be ground by ordinary ceramic stone, now the ceramic diamond stone can provide a much better cut.
4. Ceramic diamond stone is ideal for lapping all kinds of harden steels, EDM surface, tungsten carbide, ceramics and glasses efficiently.

規格 / Specifications:

單位 / Unit : mm

	#200	#400	#600	#800
1 x 4 x 100	SDS-1042	SDS-1044	SDS-1046	SDS-1048
1 x 6 x 100	SDS-1062	SDS-1064	SDS-1066	SDS-1068
1 x 10 x 100	SDS-1102	SDS-1104	SDS-1106	SDS-1108
∅ 3 x 100	SDG-302	SDG-304	SDG-306	SDG-308

其他粒度及尺寸亦可訂製。在某些特殊的用途，氮化硼纖維油石亦可訂製，敬請指名訂購。

In some special applications, ceramic CBN stones are also available, depend on your request.

鑽石膏 / Diamond Compounds 鑽石微粉 / Diamond Micron Powders

鑽石膏 Diamond Compounds



編號 Order no.	顆粒尺寸 Micron range (μm)	相等篩目 Mesh size (approx.)	標示顏色 Color code
PDR-280	0.5 (0-1)	#28,000	白 / White
PDR-140	1 (0-2)	#14,000	白 / White
PDR-080	3 (2-4)	#8,000	黃 / Yellow
PDR-050	4.5 (3-6)	#5,000	淺棕 / Light brown
PDR-030	6 (4-8)	#3,000	橙 / Orange
PDR-020	8 (6-10)	#2,000	淺紫 / Lilac
PDR-018	9 (6-12)	#1,800	綠 / Green
PDR-015	13 (10-16)	#1,500	粉紅 / Pink
PDR-012	15 (10-20)	#1,200	藍 / Blue
PDR-010	17.5 (15-20)	#1,000	深綠 / Dark green
PDR-008	25 (20-30)	#800	咖啡 / Brown
PDR-006	35 (30-40)	#600	紅 / Red
PDR-004	50 (40-60)	#400	紫 / Purple
PDR-002	90 (80-100)	#200	黑 / Black

說明：

1. 標準規格品為油溶性，若需水溶性鑽石膏，請指明訂購。
2. 標準容量為5公克，其他容量：10公克或18公克裝，亦可指訂。
3. 若需稀釋使用，本公司亦提供稀釋油。
4. 高濃度系列亦可依需求而提供。

Remark :

1. Oil soluble is standard carries, other carries depend on your request.
2. Containers : Plastic syringes, 5 grams per syringe. Others (10 or 18 grams) depend on your request.
3. We also supply thinners for your special applications.
4. High concentrations diamond compounds is also available, depend on your requirement.

鑽石微粉 Diamond Micron Powders



編號 / Order no.		顆粒尺寸 Micron range (μm)	相等篩目 Mesh size (approx.)
10 Carat	50 Carat		
DR-1280	DR-5280	0.5 (0-1)	#28,000
DR-1140	DR-5140	1 (0-2)	#14,000
DR-1080	DR-5080	3 (2-4)	#8,000
DR-1050	DR-5050	4.5 (3-6)	#5,000
DR-1030	DR-5030	6 (4-8)	#3,000
DR-1018	DR-5018	9 (6-12)	#1,800
DR-1012	DR-5012	15 (10-20)	#1,200
DR-1008	DR-5008	25 (20-30)	#800
DR-1006	DR-5006	35 (30-40)	#600
DR-1004	DR-5004	50 (40-60)	#400
DR-1002	DR-5002	90 (80-100)	#200

說明：

1. 一品牌鑽石微粉乃經過精密設備嚴格篩選，粒度精確顆粒結晶形狀劃一。它適用於各種鋼模、超硬合金、陶瓷、寶石、半寶石等之精密拋光或鏡面拋光。
2. 對於某些需求更精密或更均勻表面拋光之要求，請購時特別指明，本公司將提供更精密顆粒尺寸之微粉供選用。

Remark :

1. Our micron powders are precision graded from virgin material and especially designed for lapping and polishing operations. Particularly, those requiring the strictest dimensions accuracy and the finest surface finish.
2. For works that require ultra high finish, we also supply powders with closer tolerance of the micron range upon your request.



棕刷及木條 / WOOD BOBS & BRUSH

木條 / Lapping Wood Stick

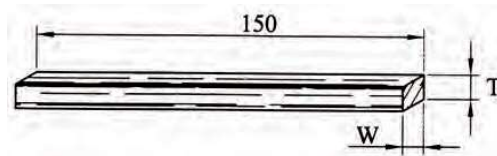

單位 / Unit : mm

Order.no.	AFW-05H	AFW-06H	AFW-07H	AFW-08H
T x W	6.4 x 6.4	3.2 x 6.4	6.4 x 9.5	6.4 x 12.7

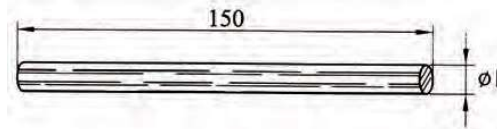

Order.no.	AFW-01H	AFW-02H	AFW-03H	AFW-04H
øD	ø3.2	ø4.7	ø6.4	ø9.5

木棒 / Wood Bobs

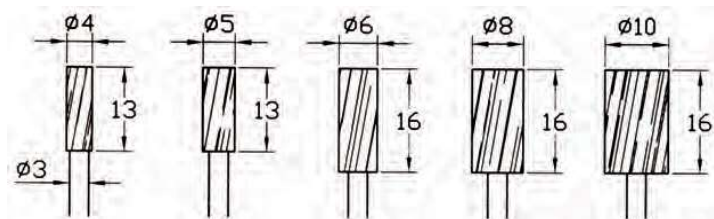

AFM-01

AFM-02

AFM-03

AFM-04

AFM-05

棕刷 / Brush

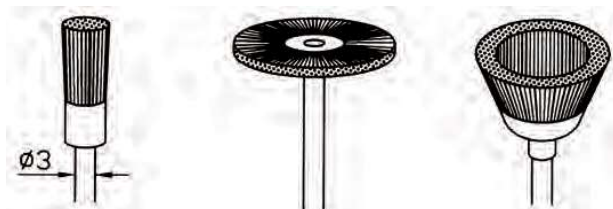

Order no.	AFB-01	AFB-02	AFB-03	AFB-04	AFB-05	AFB-06
øD	ø4.8	ø6.4	ø19	ø25.4	ø9/16"	ø1"



羊毛輪 / Felt Bobs



Felt Bobs - $\varnothing 3.0\text{mm}$ Shank

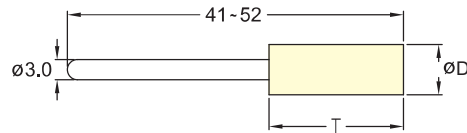

單位 / Unit : mm

Order no.	AB-0408A	AB-0509A	AB-0610A	AB-0810A	AB-1014A	AB-1220A	AB-1520A
$\varnothing D$	4	5	6	8	10	12	15
T	8	9	10	10	14	20	20
Order no.	AB-2020A	AB-0408C	AB-0509C	AB-0610C	AB-0810C	AB-1013C	AB-1214C
$\varnothing D$	20	4	5	6	8	10	12
T	20	8	9	10	10	13	14
Order no.	AB-1220C	AB-0410J	AB-0512J	AB-0616J	AB-0817J	AB-1014J	AB-1020J
$\varnothing D$	12	4	5	6	8	10	10
T	20	10	12	16	17	14	20
Order no.	AB-1220J	AB-1225J	AB-08B	AB-10B	AB-12B	AB-18B	AB-1014R
$\varnothing D$	12	12	8	10	12	18	10
T	20	25	-	-	-	-	14
Order no.	AB-1225R	AB-1218T	AB-1218H	AB-0610K	AB-0814K	AB-1014K	AB-1220K
$\varnothing D$	12	12	12	6	8	10	12
T	25	18	18	10	14	14	20

羊毛輪 / Felt Bobs

羊毛輪 / Felt Bobs - $\phi 6.0\text{mm}$ Shank

單位 / Unit : mm

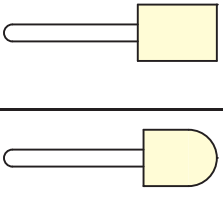
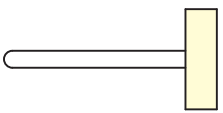
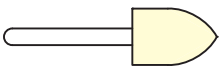
	Order No.	ϕD	T
	AC-1225A	12	25
	AC-1525A	15	25
	AC-2025A	20	25
	AC-2530A	25	30
	AC-1520C	15	20
	AC-2025C	20	25
	AC-2530C	25	30
	AC-3208E	32	8
	AC-4010E	40	9.6
	AC-1525K	15	25
	AC-2025K	20	25
	AC-2530K	25	30

其他羊毛製品 / Other Felt Products

單位 / Unit : mm

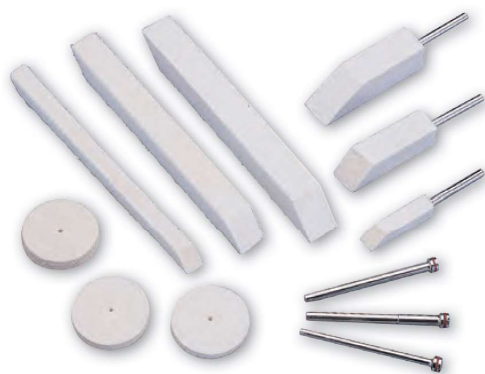

羊毛條 / Felt Stick

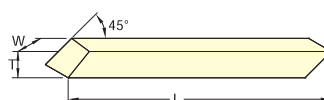

Order.no.	AB-S06	AB-S10
W x T x L	6 x 6 x 100 x 45°	10 x 10 x 100 x 45°

帶柄羊毛條 / Mounted Felt Stick

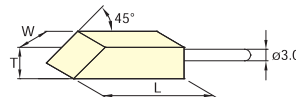

Order.no.	AB-R06	AB-R10	AB-R12
W x T x L	6 x 6 x 25	10 x 10 x 35	12 x 12 x 45

軸柄 / Mandrel For Felt Disc

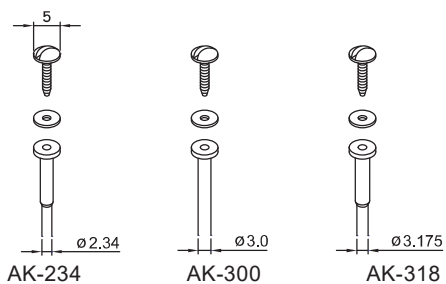

羊毛片 / Felt Disc

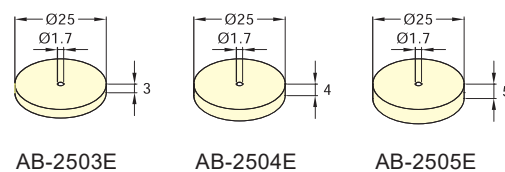



鑽石砂布 / Diamond Foils



- 鑽石砂布是以銅箔為基材，電著上一層鑽石粉，鑽石磨料佈滿整個銅箔表面。其特色為有較長之工具壽命，可以用刀片自由裁剪成所需尺寸及形狀，然後黏貼在各種工具上，成為您所需的自製工具。其優異的切削效果及多種粒度可供選擇，適合各種模具、鎢鋼、硬陶瓷、石材、玻璃等之研磨及拋光。另一種運用為將之黏在機器零件上增加耐磨耗及防止打滑。

Diamond powders are fully sprayed on the surface of copper foil, this features in longer tool life. The diamond foils can be cut to any shape & size easily, and stick on to your own tools, thus allowing for a whole range of tailored tools.

Aggressive cutting action and wide range of grit sizes produce fast cutting or polishing on hard steels of any hardness、tungsten carbides、stones、glass and hard ceramics...etc.

Other application of diamond foils is to stick on parts of machine to increase the wear resistant and avoid the sliding.

尺寸 Dimensions	粒度與編號 / Grit size & Order no.								
	#120	#150	#200	#300	#400	#600	#800	#1200	#1800
10 x 100mm	XF-1012	XF-1015	XF-1020	XF-1030	XF-1040	XF-1060	XF-1080	XF-1120	XF-1180
50 x 100mm	XF-2012	XF-2015	XF-2020	XF-2030	XF-2040	XF-2060	XF-2080	XF-2120	XF-2180
100 x 100mm	XF-3012	XF-3015	XF-3020	XF-3030	XF-3040	XF-3060	XF-3080	XF-3120	XF-3180
200 x 200mm	XF-4012	XF-4015	XF-4020	XF-4030	XF-4040	XF-4060	XF-4080	XF-4120	XF-4180

說明：標準品全部將砂布背膠，只要撕下保護層即可使用。若特殊用途可指定無背膠砂布，自行用其他方式將砂布固著於所需之工具或零件上。

Remark : All standard foils come with PSA backing, when using, please remove the backing paper.

The foils without PSA backing are also available on demand. For special applications, the users may use his own method to stick the foil on to the tools or parts.

鑽石砂布、網狀鑽石布之運用例：

Application Example of Diamond Foils & Diamond Cloth:



鑽石布 / Diamond Cloth

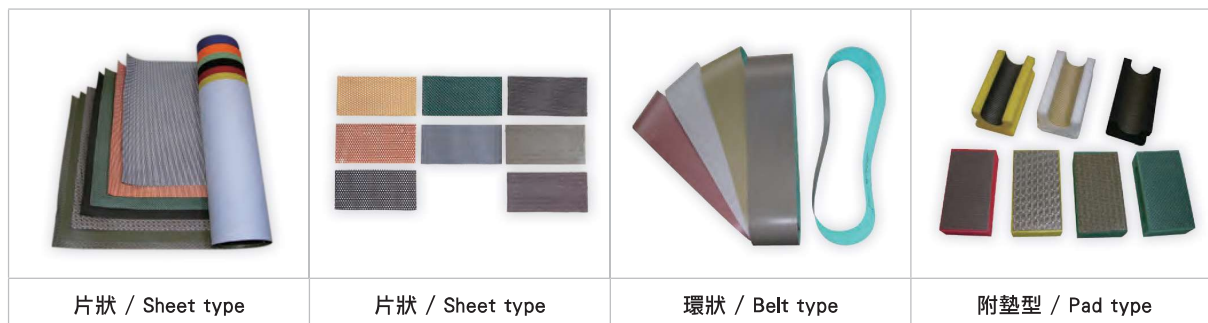

片狀 / Sheet type

片狀 / Sheet type

環狀 / Belt type

附墊型 / Pad type

The application of diamond power on a flexible cloth has allowed the development of a new generation of diamond tools.

This tools perform a more aggressive cutting action than any other abrasive tool, thanks to its flexibility and to the spacing between islands, the diamond cloth can be easily cut with scissors, thus allowing for a whole range of traditional abrasives only.

All diamond cloth products are color coded for easy identification of mesh and these series products can be in sheet, discs self-adhesive or velcro backing, or in belt type.

Applications :

The applications of diamond cloth are:
Wet grinding (lapping) harden steel of any hardness, tungsten carbide, hard ceramic coated steels, glass, hard ceramic, marble, granite and stone...etc, or for the lapping of mold and die.

鑽石布是將鑽石粉以電著法或樹脂結合法固著於帆布上,以前這種產品只有傳統砂布而已。

不同於傳統砂布的是,它有極佳的切削力,且在磨料與磨料間留有空隙作為研磨時逃屑用,因此研磨時不易塞目,且研磨後之工件表面非常均勻。

鑽石布可以用刀片或剪刀輕易地剪裁成所需要之尺寸,做成所需之工具。

鑽石布的粒度均以不同之顏色標示以資區別。它可為片狀亦可將之背膠作成環帶狀。

用途：

鑽石布的運用很廣泛,例如:大理石,花崗石..等石材加工。任何硬度之硬質鋼材,碳化鎢,硬陶瓷披覆鋼材,硬陶瓷...等研磨,玻璃之倒角及磨邊,各種模具之研磨及拋光。

規格 / Specifications:

單位 / Unit : mm

粒度 Grit size	標示顏色 Color	結合劑 Bond Material	尺寸與編號 / Dimensions & Order No.			
			50 X 100	100 X 100	1,170 X 295	690 X 295
#60	綠色 / Green	鎳 / Ni bond	XZ-1006N	XZ-2006N	XZ-5006N	-
#120	黑色 / Black	鎳 / Ni bond	XZ-1012N	XZ-2012N	XZ-5012N	-
#200	紅色 / Red	鎳 / Ni bond	XZ-1020N	XZ-2020N	XZ-5020N	-
#400	黃色 / Yellow	鎳 / Ni bond	XZ-1040N	XZ-2040N	XZ-5040N	-
#600	白色 / White	鎳 / Ni bond	XZ-1060N	XZ-2060N	XZ-5060N	-
#1000	藍色 / Blue	鎳 / Ni bond	XZ-1100N	XZ-2100N	XZ-5100N	-
#500	白色 / White	樹脂 / Resin Bond	XZ-1050R	XZ-2050R	-	XZ-6050R
#1000	藍色 / Blue	樹脂 / Resin Bond	XZ-1100R	XZ-2100R	-	XZ-6100R
#8000	橙色 / Orange	樹脂 / Resin Bond	XZ-1800R	XZ-2800R	-	XZ-6800R

說明 / Remark :

- 標準尺寸 50 X 100mm 及 100 X 100mm 均有背膠,若不背膠請指明。
 - 其他尺寸或形狀之鑽石布,請與我們業務人員聯絡。
1. Standard 50 X 100mm and 100 X 100mm come with PSA backing, others come without PSA backing, please specify.
2. Other size or type (shape), depend on your request.

貝斯迪亞® 纖維油石 / BESDIA® Ceramic Fiber Stones



全新的貝斯迪亞® 纖維油石，採用精選陶瓷纖維以獨特的結合材料及製造方法，比以前我們銷售的產品，有下列優點：

- 有更好的抗折強度，使纖維油石更不易折斷。
- 在相同的工作條件下，增加 10 ~ 20% 以上的研磨效率。
- 在絕大多數的工作條件下，增加 10 ~ 30% 以上的研磨比 (工具壽命更長)

All New BESDIA® Ceramic Fiber Stone uses the most precious ceramic fibers combined with the unique bonding material and manufacturing process. Compare to the previous one we sold, advantages :

- Better bending strength makes fiber stones not broken easily.
- The polishing efficiency increases 10% ~ 20% under the same working conditions.
- The lifetime increases 10% ~ 30% under most of the same working conditions.

規格 / Specifications :

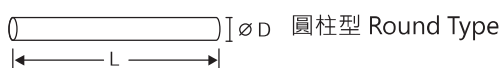

粒度與顏色 / Grit Size & Color Code :

粒度 / Grit size	#180	#250	#320	#400	#700	#1000	#1200
顏色 Color code	咖啡色 Coffee	橙色 Orange	灰色 Grey	藍色 Blue	黃色 Yellow	白色 White	橘紅色 Red Orange
代號 / Code	C	O	G	B	Y	W	R

粒度與編號 / Grit Size & Order No :

單位 / Unit : mm

T x W x L (Ø D x L)	粒度與編號 Grit Size & Order No.						
	#180	#250	#320	#400	#700	#1000	#1200
1 x 4 x 100	BSC-1004	BSO-1004	BSG-1004	BSB-1004	BSY-1004	BSW-1004	BSR-1004
1 x 6 x 100	BSC-1006	BSO-1006	BSG-1006	BSB-1006	BSY-1006	BSW-1006	BSR-1006
1 x 10 x 100	BSC-1010	BSO-1010	BSG-1010	BSB-1010	BSY-1010	BSW-1010	BSR-1010
Ø 3.0 x 100	BGC-30	BGO-30	BGG-30	BGB-30	BGY-30	BGW-30	BGR-30

說明：#320 灰色可取代舊有的 #280 黑色及 #360 海軍藍。

Note: #320 Grey instead of #280 Black and #360 Navy Blue of old stones.



迷你纖維油石 / Mini Ceramic Fiber Stones



迷你纖維油石是將纖維油石切成微細尺寸，從0.5 x 0.5mm到1 x 2mm。專門使用於各種模具之細微部位或是其他類似之加工。由於陶瓷纖維具有高抗折強度，可解決一般油石或紅寶石易斷的困擾。

用途：

迷你纖維油石可適用於各種模具之研磨及各種零件之精細拋光。尤其是雕刻部位之加工，微小肋部，模具角部精細拋磨，以及各種微細或複雜部位之加工。

Mini Ceramic Fiber Stones are cut by ceramic fiber stone, their size from 0.5 x 0.5 mm to 1 x 2mm. Ideal for various mold and dies detail lapping.

Traditional oil stone and ruby stones in such a small sizes are very easy to break, while mini ceramic stone provide high strength and high elasticity. Due to its hard to break, they resolve the problem of using these stones.

Applications

It is good for all type of molds and dies fine and super fine finishing. Especially for engraving parts, slight ribs, R ribs, corners, complicated area and details.

Besides, all other tool parts that needs details lapping, Our mini ceramic fiber stone will be the wonderful tools.

規格 / Specifications:

尺寸 (mm) Dimensions (mm)	粒度與編號 Grit Size & Order No.				使用夾頭 Holder
	#250	#400	#700	#1200	
0.5 x 0.5 x 50L	MOS-055	MBS-055	MYS-055	MRS-055	XH-007
0.7 x 0.7 x 50L	MOS-075	MBS-075	MYS-075	MRS-075	XH-009
0.9 x 0.9 x 50L	MOS-095	MBS-095	MYS-095	MRS-095	XH-013
1.0 x 2.0 x 100L	MOS-121	MBS-121	MYS-121	MRS-121	XH-200
ø 0.9 x 50L	MOG-105	MBG-105	MYG-105	MRG-105	XH-009
ø 2.0 x 100L	MOG-201	MBG-201	MYG-201	MRG-201	XH-200

Application Example



油石夾柄 / Tool Holders



單位 / Unit : mm

編號 Order No.	可挾持尺寸 Holding Capacity	運用 Applications
XH-007	Square 0.5 x 0.5 or Round \varnothing 0.7	迷你纖維油石 For Mini Fiber Stone
XH-009	Square 0.7 x 0.7 or Round \varnothing 0.9	迷你纖維油石 For Mini Fiber Stone
XH-200	Flat 2 x 1 or Round \varnothing 2.0	迷你纖維油石 For Mini Fiber Stone
XH-013	Square 0.9 x 0.9 or Round \varnothing 1.3	迷你纖維油石 For Mini Fiber Stone
XH-22	Round 3.0	纖維油石 For Fiber Stone
XH-041	平形/ Flat 4 x 1	纖維油石 For Fiber Stone
XH-061	平形/ Flat 6 x 1	纖維油石 For Fiber Stone
XH-101	平形/ Flat 10 x 1	纖維油石 For Fiber Stone
XH-062	平形/ Flat 6 x 2 ~ 6 x 3	一般油石 For Oil Stone
XH-133	平形/ Flat 13 x 3	一般油石 For Oil Stone
XH-136	平形/ Flat 13 x 6.3	一般油石 For Oil Stone

帶柄砂輪 / Mounted Points



規格 / Specifications:

單位 / Unit : mm

256A	308A	410A	510A	612A	816A	1016A*	30B	40B
50B	60B	80B	100B	120B	308T	310T	412T	710T
813R	1224R*	609S	412J	616J	816J	1016J	612P	815P
1018P*	306K	412K	515K	816K	132E	133E	162E*	163E*

說明 / Note:

- 標準柄徑為 $\varnothing 3.0\text{mm}$,其他柄徑為 $\varnothing 2.34\text{mm}$ 或 $\varnothing 3.175$,請指明訂購。
 $\varnothing 3.0\text{mm}$ shank is standard, others ($\varnothing 2.34$ or $\varnothing 3.175\text{mm}$) depend on request.
- 有*之尺寸,無法提供 $\varnothing 2.34\text{mm}$ 柄。
 The tools with "*" marked, just available for $\varnothing 3.0$ & $\varnothing 3.175$ shank.

油石 / Oil Polishing Stones 彈性帶柄砂輪 / Elastic Mounted Points

油石 / Oil Polishing Stones:



- **EDM** 系列油石：
主要用來去除各種模具EDM加工後之硬化表層。
- **DF** 系列油石：
主要使用於一般模具機械加工之痕跡去除及拋光作業。
- **EDM** series stones are specially for removing the hard scale generated by the EDM process on all type of mold and die steels.
- **DF** series stones are suitable for removing the machined surface scratch and general lapping & polishing all mold and die steels.

尺寸 / Dimensions:

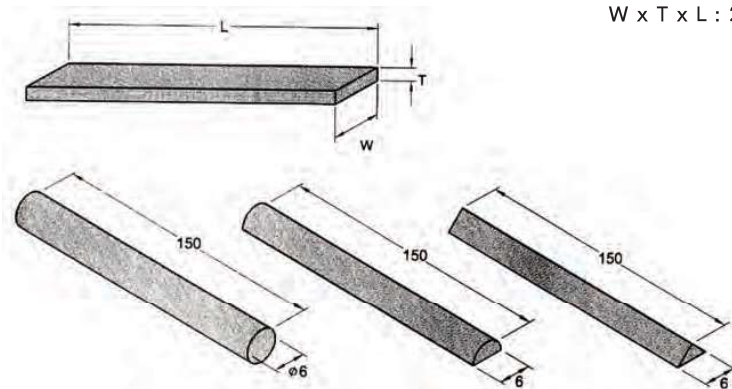

W x T x L : 25 x 6 x 150 , 25 x 3 x 150 , 13 x 13 x 150
13 x 6 x 150 , 13 x 3 x 150 , 13 x 1.6 x 150
6 x 6 x 150 , 6 x 3 x 150 , 10 x 10 x 150

粒度 / Grit size : #120 , #180 , #220 , #320 , #400 , #600 , #800 , #1000

彈性帶柄砂輪 / Elastic Mounted Points:

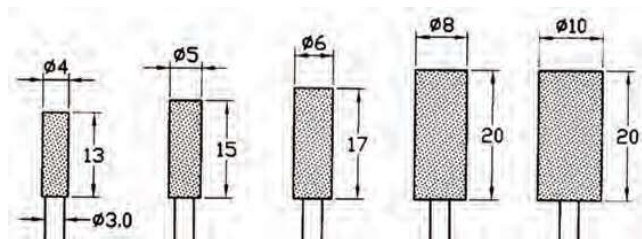

單位 / Unit : mm

	粒度/Grit size	編號/Order no.				
牛皮砂輪/Resinoid point	#120	N413	N515	N617	N820	N1020
海綿砂輪/Rubberize point	#120	R413	R515	R617	R820	R1020