



BMT 200KP



BMT 18CE



BMT 315CS

BEMATO® SAWING MACHINE

BEMATO

SAWING MACHINE



BMT 40KV



BMT 712G



BMT 300N



STRIVING FOR SERVICE
AND SATISFACTION

SINCE 1976

BENIGN ENTERPRISE Co., LTD.

SUITE 4, 5F., NO. 20, TA-LONG ROAD, TAICHUNG, TAIWAN R.O.C.
MAILING ADDRESS: P.O. BOX 747 TAICHUNG, TAIWAN R.O.C.

TEL: 886-4-23233016 FAX: 886-4-23232826 . 23238341
E-MAIL: service@e-bemato.com http://www.e-bemato.com



BEMATO 2019.05 001



STRIVING FOR SERVICE
AND SATISFACTION

COMPANY NAME	: BENIGN ENTERPRISE CO., LTD.
ADDRESS	: SUITE 4, 5F., NO.20, TA-LONG ROAD, TAICHUNG, TAIWAN
TEL	: +886-4-23233016
FAX	: +886-4-23232826, 23238341
E-MAIL	: service@e-bemato.com
WEBSITE:	: www.e-bemato.com
REGISTERED TRADEMARK	: BEMATO
COMPANY ESTABLISHED	: 1976
CAPITAL	: US\$2,000,000.00
EMPLOYEE	: 25 (Includes 4 QC inspectors)
GENERAL MANAGER	: MR. DAVID WU
MAIN ACTIVITY	: 1. EXPORT MACHINE TOOLS, MACHINE TOOLS ACCESSORIES, INDUSTRIAL SUPPLIES, PNEUMATIC TOOLS AND OEM COMPONENTS 2. PURCHASING AGENT FOR FOREIGN COMPANIES 3. SHIPMENTS CONSOLIDATION
MAIN EXPORT MARKETS	: 1. EUROPE 2. NORTH AMERICA 3. MIDDLE & SOUTH AMERICA 4. AUSTRALIA & N.Z. 5. ASIA 6. SOUTH AFRICA
MAIN EXPORT PRODUCTS	: <u>A) MACHINE TOOLS</u> 1. LATHES (CNC & CONVENTIONAL) 2. MILLING MACHINES (CNC & CONVENTIONAL) 3. MACHINING CENTERS (VERTICAL & HORIZONTAL) 4. GRINDING MACHINES (SURFACE, CYLINDRICAL, INTERNAL, CENTERLESS, TOOL & CUTTER) 5. SAWING MACHINES (HORIZONTAL, VERTICAL, & CIRCULAR) 6. DRILLING MACHINES (BENCH, FLOOR, RADIAL, NC, VERTICAL & HORIZONTAL) 7. WOODWORKING MACHINES (DIY & INDUSTRIAL) 8. WIRE CUT & EDM (DIE SINKER, MICRO DRILL) 9. SHEET METAL MACHINES (SHEAR, PRESS BRAKE, FOLDING, BENDING, ROLLING) 10. SPECIAL MACHINES, OEM COMPONENTS (STAMPING, PLASTIC INJECTION, ALUMINUM EXTRUSION, CASTINGS, ETC.) <u>B) MACHINE TOOLS ACCESSORIES & INDUSTRIAL TOOLS & SUPPLIES</u> <u>C) PNEUMATIC TOOLS</u>

HORIZONTAL BANDSAW

PORTABLE

4" (90~115 mm)..... P. 1 - 2

PORTABLE / MANUAL

5" (125~130 mm)..... P. 3 - 6

6" (150~153 mm)..... P. 7

6.7" (170 mm)..... P. 8 - 9

7" (178~180 mm)..... P. 10 - 12

MANUAL / SEMI-AUTOMATIC

7.3" (185 mm)..... P. 13

8" (200~205 mm)..... P. 13

8.8" (220~225 mm)..... P. 14 - 19

9" (227~230 mm)..... P. 20 - 23

9.5" (240 mm)..... P. 24

MANUAL / SEMI-AUTOMATIC / FULLY-AUTOMATIC

10" (250 mm)..... P. 25 - 28

10" (254~255 mm)..... P. 29 - 34

10.5" (260~270 mm)..... P. 35 - 44

12" (300~305 mm)..... P. 45 - 49

13" (310~331 mm)..... P. 50 - 55

SEMI-AUTOMATIC / FULLY-AUTOMATIC

14" (350~360 mm)..... P. 56 - 60

15" (380 mm)..... P. 61 - 62

16.5" (420 mm)..... P. 63

18" (460 mm)..... P. 63 - 68

20" (500~510 mm)..... P. 69

21" (530~550 mm)..... P. 70 - 71

22" (560~580 mm)..... P. 72 - 73

25" (620~650 mm)..... P. 73 - 74

27.6" (700 mm)..... P. 75

31.5" (800 mm)..... P. 75 - 77

43.3" (1100 mm)..... P. 78

51.2" (1300 mm)..... P. 78

CNC Fully Automatic..... P. 79

VERTICAL BANDSAW

Mechanical Variable Speed..... P. 81 - 91

Inverter Variable Speed..... P. 92 - 95

Vertical Block / Plate..... P. 96 - 97

CIRCULAR SAW

Steel Cutting Circular Saw..... P. 99 - 102

Metal Cutting TCT Chop Saw..... P. 103

Abrasive Cut-Off Saw..... P. 103 - 105

Aluminum Circular Saw..... P. 106 - 107

Circular Sawing Machine..... P. 108 - 115

NC Circular Sawing Machine..... P. 116

Automatic Circular Sawing Machine..... P. 117 - 118

Double Blade Angular Sawing Machine.... P. 119 - 120

HACKSAW

Hacksaw..... P. 121 - 122

4" (90~115 mm)

BMT 90SL

- Portable Bandsaw -



*Machine shown with optional accessories

FEATURES:

- ◆ Swivel arm

MODEL	BMT 90SL
Capacity (90°)	● 85 mm, ■ 85 x 120 mm
Capacity (45°)	● 65 mm, ■ 60 x 65 mm
Blade Size	12.7 x 0.64 x 1300 mm
Blade Speed	3 steps, 20/29/51 mpm
Blade Motor	1/3 HP
Packing Size	750 x 315 x 470 mm
N.W. / G.W.	26 kgs / 28 kgs
Container Loads	275 sets / 20'

*Specifications are subject to change without prior notice.

BMT 100YM

- Portable Bandsaw -



*Machine shown with optional accessories

FEATURES:

- ◆ Swivel arm
- ◆ Blade tension gauge
- ◆ Aluminum saw-frame & steel base
- ◆ Two protectors (one controlling amps, other controlling temperature of the motor)
- ◆ Anti-reset safety function

MODEL	BMT 100YM
Capacity (90°)	● 105 mm, ■ 100 x 100 mm
Capacity (45°)	● 65 mm, ■ 65 x 65 mm, ■ 60 x 65 mm
Blade Size	13 x 0.65 x 1330 mm
Blade Speed	Vari. speed, 30~80 mpm
Blade Motor	1-1/8 HP DC motor
Packing Size	724 x 375 x 446 mm
N.W. / G.W.	18 kgs / 19 kgs
Container Loads	240 sets / 20'

*Specifications are subject to change without prior notice.

BMT 168T

- Portable Bandsaw -



*Machine shown with optional accessories

FEATURES:

- ◆ Swivel arm
- ◆ Toggle switch
- ◆ Suitable for cutting solid metal, thick or thin metal pipes

MODEL	BMT 168T
Capacity (90°)	● 100 mm, ■ 100 x 150 mm
Capacity (45°)	● 85 mm, ■ 85 x 100 mm
Blade Size	13 x 0.65 x 1470 mm (14T)
Blade Speed	45 mpm / 4P @ 50Hz 54 mpm / 4P @ 60Hz
Blade Motor	1/2 HP
Packing Size	724 x 381 x 458 mm
N.W. / G.W.	23 kgs / 27 kgs
Container Loads	240 sets / 20'

*Specifications are subject to change without prior notice.

BMT 115 / BMT 115SL

- Portable Bandsaw -



*Machine shown with optional accessories

FEATURES:

- ◆ Swivel vise for BMT 115
- ◆ Swive arm for BMT 115SL
- ◆ Optional N.V.R switch
- ◆ Optional machine stand for BMT 115SL
- ◆ Optional quick grip vise for BMT 115SL

MODEL	BMT 115	BMT 115SL
Capacity (90°)	● 110 mm, ■ 100 x 140 mm	● 110 mm, ■ 100 x 145 mm
Capacity (45°)	-	● 85 mm, ■ 70 x 95 mm
Blade Size	12.7 x 0.64 x 1640 mm	
Blade Speed	3 steps, 20/29/50 mpm	
Blade Motor	1/2 HP	
Packing Size	1020 x 330 x 400 mm	1035 x 445 x 455 mm
N.W. / G.W.	60 kgs / 62 kgs	56 kgs / 58 kgs
Container Loads	231 sets / 20'	135 sets / 20'

*Specifications are subject to change without prior notice.

5" (125~130 mm)

BMT 125YM

- Portable Bandsaw -



*Machine shown with optional accessories

FEATURES:

- ◆ Swivel arm
- ◆ Blade tension adjustment from the front
- ◆ Aluminum saw-frame & steel base
- ◆ Two protectors (one controlling amps, other controlling temperature of the motor)
- ◆ Anti-reset safety function

MODEL	BMT 125YM
Capacity (90°)	● 125 mm, ■ 125 x 125 mm, ■ 125 x 130 mm
Capacity (45°)	● 80 mm, ■ 80 x 80 mm
Capacity (60°)	● 50 mm, ■ 50 x 50 mm
Blade Size	13 x 0.65 x 1440 mm
Blade Speed	Vari. speed, 30~80 mpm
Blade Motor	1.35 HP DC motor
Packing Size	724 x 375 x 446 mm
N.W. / G.W.	19 kgs / 21 kgs
Container Loads	240 sets / 20'

*Specifications are subject to change without prior notice.

BMT 125DV1

- Portable Bandsaw -



*Machine shown with optional accessories

FEATURES:

- ◆ Swivel arm
- ◆ On/off and trigger switch
- ◆ Easy for outdoor working
- ◆ Economical cost-per-cut

MODEL	BMT 125DV1
Capacity (90°)	● 125 mm, ■ 120 x 120 mm
Capacity (45°)	● 70 mm, ■ 120 x 70 mm
Capacity (60°)	● 35 mm, ■ 65 x 35 mm
Blade Size	13 x 0.65 x 1440 mm
Blade Speed	Vari. speed, 23~75 mpm
Blade Motor	2/5 HP
Packing Size	730 x 383 x 475 mm
N.W. / G.W.	22 kgs / 25 kgs

*Specifications are subject to change without prior notice.

BMT 128

- Manual Bandsaw / US Type -



*Machine shown with optional accessories

FEATURES:

- ◆ Swivel arm
- ◆ 5" x 6" step pulley
- ◆ Vertical cutting table is not available for CE

MODEL	BMT 128	BMT 128HDR
Capacity (90°)	● 128 mm, ■ 115 x 150 mm	● 128 mm, ■ 128 x 150 mm
Capacity (45°)	● 76 mm, ■ 76 x 115 mm	(R&L 45°) ● 95 mm, ■ 75 x 95 mm
Capacity (60°)	-	● 44 mm, ■ 44 x 56 mm
Blade Size	12.7 x 0.65 x 1635 mm	
Blade Speed	3 steps 24/37/61 mpm @60Hz, 20/29/50 mpm @50Hz	
Blade Motor	1/3 HP	
Packing Size	965 x 330 x 381 mm	1041 x 445 x 559 mm
N.W. / G.W.	60 kgs / 61 kgs	78 kgs / 82 kgs
Container Loads	249 sets / 20'	108 sets / 20'

*Specifications are subject to change without prior notice.

BMT 128HDR

- Manual Bandsaw / US Type -



FEATURES:

- ◆ Dual miter cutting
- ◆ Optional quick fixture lock vise (one way 45° swivel only)

HORIZONTAL BANDSAW — VERTICAL BANDSAW — CIRCULAR SAW — HACKSAW

5" (125~130 mm)

BMT 130JD

- Portable Bandsaw -

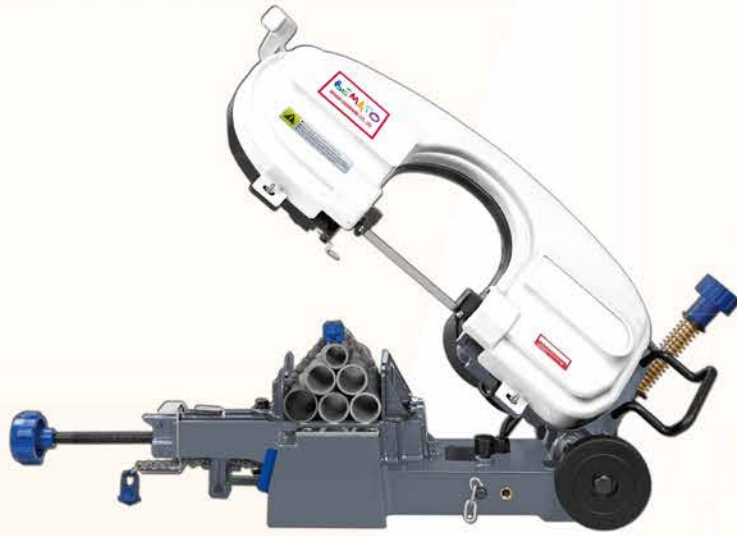

*Machine shown with optional accessories

FEATURES:

- ◆ Clean and accurate cutting with durable design.
- ◆ Rapid switch vise-clamping system for multi-sizes, materials cutting.
- ◆ The vise-clamping system with chain for pipes, unregular shapes, bundle cutting.
- ◆ Compact and portable, take out with moving wheels.
- ◆ Instantly changed to vertical cutting.
- ◆ Low-voltage start-up design on high-efficiency motor.
- ◆ Safety protection upgrade with overload and full line-covered design.
- ◆ Without CE

MODEL	BMT 130JD
Capacity (90°)	● 130 mm, ■ 115 mm
Capacity (45°)	● 50 mm, ■ 50 mm
Blade Size	13 x 0.65 x 1440 mm
Blade Speed	40 mpm @ 50 Hz / 48 mpm @ 60 Hz
Motor	1/2 HP
Packing Size	830 x 440 x 405 mm
N.W. / G.W.	36 kgs / 40 kgs

*Specifications are subject to change without prior notice.

BMT 135CW

- Portable Bandsaw -



*Machine shown with optional accessories

FEATURES:

- ◆ Swivel arm

MODEL	BMT 135CW
Capacity (90°)	● 150 mm, ■ 150 x 150 mm
Capacity (45°)	● 100 mm, ■ 130 x 100 mm
Capacity (60°)	● 60 mm, ■ 60 x 60 mm
Blade Size	12.7 x 0.65 x 1735 mm
Blade Speed	65 mpm
Blade Motor	1/2 HP
Packing Size	1130 x 570 x 840 mm
N.W. / G.W.	78 kgs / 90 kgs
Container Loads	40 sets / 20'

*Specifications are subject to change without prior notice.

6" (150~153 mm)

BMT 150YM

- Portable Bandsaw -



*Machine shown with optional accessories

FEATURES:

- ◆ Aluminum saw-frame
- ◆ Two protectors (one controlling amps, other controlling temperature of the motor)
- ◆ Anti-reset safety function

MODEL	BMT 150YM
Capacity (90°)	● 150 mm, ■ 140 x 140 mm, ■ 150 x 140 mm
Capacity (45°)	● 100 mm, ■ 100 x 100 mm, ■ 100 x 100 mm
Capacity (60°)	● 70 mm, ■ 65 x 65 mm, ■ 65 x 70 mm
Blade Size	13 x 0.9 x 1735 mm
Blade Speed	Vari. speed, 30~80 mpm
Motor	DC 2 HP
Machine Size	1000 x 430 x 495 mm
Packing Size	964 x 457 x 555 mm
N.W. / G.W.	30 kgs / 32 kgs
Container Loads	120 sets / 20'

*Specifications are subject to change without prior notice.

BMT 153DV3

- Portable Bandsaw -



*Machine shown with optional accessories

FEATURES:

- ◆ Swivel arm
- ◆ Two operation mode
- ◆ Saw bow and base are aluminum
- ◆ DC motor
- ◆ Cut off limit switch
- ◆ Emergency stop button

MODEL	BMT 153DV3
Capacity (90°)	● 153 mm, ■ 153 x 175 mm
Capacity (45°)	● 110 mm, ■ 120 x 110 mm
Capacity (60°)	● 70 mm, ■ 60 x 70 mm
Blade Size	13 x 0.65 x 1785 mm
Blade Speed	Vari. speed, 35~85 mpm
Blade Motor	1/2 HP
Packing Size	900 x 457 x 530 mm
N.W. / G.W.	38 kgs / 43 kgs

*Specifications are subject to change without prior notice.

6" (150~153 mm) / 6.7" (170 mm)

BMT 150VW

- Manual Bandsaw / EURO Type -



*Machine shown with optional accessories

FEATURES:

- ◆ Swivel arm (Single miter cutting)
- ◆ Blade tension adjustment from the front
- ◆ Aluminum saw-frame & cast iron base
- ◆ Start button inside the operation handle
- ◆ Coolant system
- ◆ Two protectors (one controlling amps, other controlling temperature of the motor)
- ◆ Anti-reset safety function

BMT 210N

- Manual Bandsaw / EURO Type -



FEATURES:

- ◆ Swivel arm (Single miter cutting)
- ◆ Coolant system
- ◆ Magnetic switch 24V & CE
- ◆ Blade tension gauge
- ◆ Hydraulic cylinder

MODEL	BMT 150VW
Capacity (90°)	● 150 mm, ■ 140 x 140 mm, ■ 150 x 140 mm
Capacity (45°)	● 100 mm, ■ 90 x 90 mm, ■ 100 x 90 mm
Capacity (60°)	● 70 mm, ■ 65 x 65 mm, ■ 65 x 70 mm
Blade Size	13 x 0.9 x 1735 mm
Blade Speed	Vari. speed, 30~80 mpm
Blade Motor	2 HP DC motor
Packing Size	964 x 457 x 565 mm (machine) 735 x 505 x 156 mm (stand)
N.W. / G.W.	108 kgs / 120 kgs
Container Loads	100 sets / 20'

MODEL	BMT 210N
Capacity (90°)	● 170 mm, ■ 150 x 150 mm, ■ 150 x 190 mm
Capacity (45°)	● 125 mm, ■ 95 x 95 mm, ■ 95 x 120 mm
Blade Size	20 x 0.9 x 2080 mm
Blade Speed	60 mpm (1 PH), 40/80 mpm (3 ph) Vari. speed, 20~90 mpm (DC motor)
Motor	1 HP / 2 HP DC motor (opt.)
Packing Size	1290 x 640 x 870 mm
N.W. / G.W.	155 kgs / 170 kgs

*Specifications are subject to change without prior notice.

6.7" (170 mm)

BMT 170YM

- Portable Bandsaw -



*Machine shown with optional accessories

FEATURES:

- ◆ Swivel arm
- ◆ Blade tension adjustment from the front
- ◆ Aluminum saw-frame & base
- ◆ Start button inside the operation handle
- ◆ Two protectors (one controlling amps, other controlling temperature of the motor)
- ◆ Anti-reset safety function

BMT 210ECO

- Manual Bandsaw / EURO Type -



FEATURES:

- ◆ Swivel arm
- ◆ Blade tension adjustment from the front
- ◆ Aluminum saw-frame & cast iron base
- ◆ Start button inside the operation handle
- ◆ Two protectors (one controlling amps, other controlling temperature of the motor)
- ◆ Anti-reset safety function
- ◆ Coolant system

MODEL	BMT 170YM	BMT 210ECO
Capacity (90°)	● 170 mm, ■ 170 x 170 mm	
Capacity (45°)	● 130 mm, ■ 130 x 130 mm, ■ 130 x 150 mm	
Capacity (60°)	● 75 mm, ■ 75 x 75 mm	
Blade Size	20 x 0.9 x 2030 mm	
Blade Speed	Vari. speed, 30~80 mpm	
Blade Motor	2.2 HP DC motor	
Coolant Motor, Tank	-	1/8 HP
Packing Size	1000 x 457 x 555 mm	1010 x 635 x 780 mm (machine) 735 x 505 x 156 mm (stand)
N.W. / G.W.	35 kgs / 38 kgs	138 kgs / 145 kgs
Container Loads	100 sets / 20'	80 sets / 20'

*Specifications are subject to change without prior notice.

6.7" (170 mm)

BMT 210SHG

- Manual Bandsaw / EURO Type-



*Machine shown with optional accessories

FEATURES:

- ◆ Miter Capability Right 0° to 60°
- ◆ Easily operating control panel
- ◆ Manual Trigger Switch or Auto-Cutting
- ◆ Quickly clamping by lever
- ◆ Hydraulic feed control cutting

MODEL	BMT 210SHG
Capacity (90°)	● 170 mm, ■ 170 x 170 mm, ■ 210 x 100 mm
Capacity (45°)	● 120 mm, ■ 110 x 110 mm, ■ 130 x 60 mm
Capacity (60°)	● 70 mm, ■ 60 x 60 mm, ■ 70 x 65 mm
Blade Size	20 x 0.9 x 2110 mm
Blade Speed	4P: 90 mpm, 8P: 45 mpm @ 50 Hz
Blade Motor	1 HP
Coolant Motor	1/25 HP
Packing Size	1150 x 600 x 910 mm
N.W. / G.W.	150 kgs / 170 kgs

*Specifications are subject to change without prior notice.

BMT 211W

- Manual Bandsaw / EURO Type-



*Machine shown with optional accessories

FEATURES:

- ◆ Coolant pump
- ◆ Magnetic switch

MODEL	BMT 211W
Capacity (90°)	● 170 mm, ■ 140 x 210 mm
Capacity (45°)	● 125 mm, ■ 140 x 125 mm
Blade Speed	40 mpm, 80 mpm
Blade Motor	1 HP
Packing Size	1300 x 580 x 780 mm
N.W. / G.W.	133 kgs / 147 kgs
Container Loads	32 sets / 20'

*Specifications are subject to change without prior notice.

7" (178~180 mm)

BMT 180SLV

- Portable Bandsaw -



*Machine shown with optional accessories

FEATURES:

- ◆ DC brushless motor
- ◆ Equipped wheels can move different places
- ◆ Quick vise design
- ◆ Hydraulic cylinder
- ◆ Suitable for cutting pipe and angle bar

MODEL	BMT 180SLV
Capacity (90°)	● 180 mm, ■ 165 x 230 mm
Capacity (45°)	● 140 mm, ■ 165 x 140 mm
Blade Size	19 x 0.9 x 2285 mm
Blade Speed	Vari. speed, 35~85 mpm
Blade Motor	1 HP
Packing Size	1150 x 380 x 590 mm
N.W. / G.W.	51 kgs / 57 kgs

*Specifications are subject to change without prior notice.

BMT 180JA / BMT 180JC

- Portable Bandsaw -



*Machine shown with optional accessories

FEATURES:

- ◆ Vise type for BMT 180JA
- ◆ Chain type for BMT 180JC
- ◆ Rapid switch vise-clamping system with down-press design
- ◆ Safety protection upgrade with overload and full line-covered design
- ◆ Compact and portable to take out with moving wheels

MODEL	BMT 180JA	BMT 180JC
Capacity (90°)	● 180 mm, ■ 150 x 150 mm	
Capacity (45°)	● 80 mm, ■ 80 x 80 mm	-
Blade Size	13 x 0.65 x 1642 mm	
Blade Speed	40 mpm @ 50Hz 48 mpm @ 60Hz	
Blade Motor	9/16 HP	
Packing Size	1030 x 500 x 470 mm	
N.W. / G.W.	44 kgs / 47 kgs	39 kgs / 43 kgs

*Specifications are subject to change without prior notice.

7" (178~180 mm)

BMT 180DSV

- Manual Bandsaw / EURO Type -



*Machine shown with optional accessories

FEATURES:

- ◆ Dual miter cutting
- ◆ DC brushless motor
- ◆ Manual or hydraulic flow control cutting

MODEL	BMT 180DSV
Capacity (90°)	● 180 mm, ■ 165 x 230 mm
Capacity (45°)	● 130 mm, ■ 165 x 70 mm
Capacity (60°)	● 100 mm, ■ 90 x 100 mm
Capacity (L45°)	● 140 mm, ■ 140 x 150 mm
Blade Size	19 x 0.9 x 2285 mm
Blade Speed	Vari. speed, 35~85 mpm
Blade Motor	1 HP
Coolant Motor, Tank	1/20 HP, 10 L
Table Height	810 mm
Packing Size	1258 x 585 x 1296 mm
N.W. / G.W.	116 kgs / 145 kgs

*Specifications are subject to change without prior notice.

BMT 712 / BMT 712A / BMT 712C

- Manual Bandsaw / US Type -



*Machine shown with optional accessories

FEATURES:

- ◆ Step pulley
- ◆ Toggle switch for BMT 712
- ◆ Magnetic switch for BMT 712A
- ◆ CE standard for BMT 712C

MODEL	BMT 712 / BMT 712A / BMT 712C
Capacity (90°)	● 180 mm, ■ 165 x 280 mm, ■ 65 x 300 mm
Capacity (45°)	● 110 mm, ■ 180 x 110 mm
Blade Size	19 x 0.9 x 2360 mm
Blade Speed	4 steps 22/33/45/65 mpm @ 50 Hz 25/40/55/80 mpm @ 60 Hz
Blade Motor	1 HP
Packing Size	1280 x 450 x 1030 mm
N.W. / G.W.	132 kgs / 133 kgs / 138 kgs / 145 kgs / 146 kgs / 151 kgs
Container Loads	42 sets / 20', 88 sets / 40'

*Specifications are subject to change without prior notice.

7" (178~180 mm)

BMT 712G

- Manual Bandsaw / US Type -



*Machine shown with optional accessories

FEATURES:

- ◆ Gear transmission
- ◆ Magnetic switch

MODEL	BMT 712G
Capacity (90°)	● 180 mm, ■ 165 x 280 mm, ■ 65 x 300 mm
Capacity (45°)	● 110 mm, ■ 180 x 110 mm
Blade Size	19 x 0.9 x 2360 mm
Blade Speed	3 steps, 39/66/82 mpm
Blade Motor	1 HP
Packing Size	1280 x 450 x 1060 mm
N.W. / G.W.	139 kgs / 153 kgs
Container Loads	42 sets / 20', 88 sets / 40'

*Specifications are subject to change without prior notice.

BMT 712SG

- Manual Bandsaw / US Type -



*Machine shown with optional accessories

FEATURES:

- ◆ Swivel arm
- ◆ Gear transmission
- ◆ CE standard

MODEL	BMT 712SG
Capacity (90°)	● 180 mm, ■ 180 x 260 mm, ■ 55 x 280 mm
Capacity (45°)	● 105 mm, ■ 120 x 105 mm
Blade Size	19 x 0.9 x 2360 mm
Blade Speed	3 steps, 39/66/82 mpm
Blade Motor	1 HP
Packing Size	1280 x 570 x 1060 mm
N.W. / G.W.	189 kgs / 208 kgs
Container Loads	34 sets / 20', 56 sets / 40'

*Specifications are subject to change without prior notice.

7.3" (185 mm)

BMT 210AY / BMT 210YC

- Manual Bandsaw / EURO Type for BMT 210AY -
- Semi-automatic Bandsaw / EURO Type for BMT 210YC -



*Machine shown with optional accessories

FEATURES:

- ◆ Swivel arm
- ◆ Blade tension adjustment from the front
- ◆ Start button inside the operation handle
- ◆ Quick clamping vise
- ◆ Coolant system

MODEL	BMT 210AY / BMT 210YC
Capacity (90°)	● 185 mm, ■ 180 x 180 mm, ■ 200 x 150 mm
Capacity (L45°)	● 110 mm, ■ 110 x 90 mm
Capacity (L60°)	● 70 mm, ■ 70 x 70 mm
Blade Size	20 x 0.9 x 2085 mm
Blade Speed	35 mpm, 75 mpm Vari. speed, 30~75 mpm (opt.)
Blade Motor	2-2/3 HP DC motor
Packing Size	1155 x 680 x 920 mm
N.W. / G.W.	190 kgs / 215 kgs
Container Loads	32 sets / 20'

*Specifications are subject to change without prior notice.

8" (200~205 mm)

BMT 812

- Manual Bandsaw / US Type -



*Machine shown with optional accessories

FEATURES:

- ◆ Toggle switch for BMT 812
- ◆ Magnetic switch for BMT 812A
- ◆ CE standard for BMT 812C
- ◆ Gear transmission for BMT 812G

MODEL	BMT 812
Capacity (90°)	● 200 mm, ■ 165 x 275 mm, ■ 55 x 300 mm
Capacity (45°)	● 120 mm, ■ 200 x 120 mm
Blade Size	19 x 0.9 x 2360 mm
Blade Speed	4 steps 22/33/45/65 mpm @ 50Hz 25/40/55/80 mpm @ 60Hz
Blade Motor	1 HP
Packing Size	1280 x 480 x 1070 mm
N.W. / G.W.	143 kgs / 163 kgs
Container Loads	42 sets / 20', 88 sets / 40'

*Specifications are subject to change without prior notice.

8.8" (220~225 mm)

BMT 270YM / BMT 270YC

- Manual Bandsaw / EURO Type for BMT 270YM -
- Semi-automatic Bandsaw / EURO Type for BMT 270YC -



*Machine shown with optional accessories

FEATURES:

- ◆ Swivel arm
- ◆ Blade tension adjustment from the front
- ◆ Start button inside the operation handle
- ◆ Quick clamping vise
- ◆ Coolant system

MODEL	BMT 270YM / BMT 270YC
Capacity (90°)	● 220 mm, ■ 210 x 210 mm, ■ 185 x 230 mm
Capacity (45°)	● 150 mm, ■ 150 x 150 mm, ■ 150 x 210 mm
Capacity (60°)	● 90 mm, ■ 90 x 90 mm, ■ 90 x 100 mm
Blade Size	27 x 0.9 x 2455 mm
Blade Speed	35 mpm, 70 mpm
Blade Motor	1.5 HP
Packing Size	1385 x 745 x 935 mm
N.W. / G.W.	250 kgs / 280 kgs
Container Loads	24 sets / 20'

*Specifications are subject to change without prior notice.

BMT 275SH

- Manual Bandsaw / EURO Type -



*Machine shown with optional accessories

FEATURES:

- ◆ Swivel arm
- ◆ Quick handle locking vise
- ◆ Manual trigger control cutting
- ◆ Hydraulic flow control cutting
- ◆ Optional blade tension indicator gauge

MODEL	BMT 275SH
Capacity (90°)	● 225 mm, ■ 195 x 195 mm, ■ 245 x 120 mm
Capacity (45°)	● 150 mm, ■ 150 x 150 mm, ■ 200 x 135 mm
Capacity (60°)	● 100 mm, ■ 90 x 90 mm
Blade Size	27 x 0.9 x 2460 mm
Blade Speed	4P: 72 mpm, 8P: 36 mpm @ 50Hz
Blade Motor	1.5 HP
Packing Size	1651 x 610 x 1092 mm
N.W. / G.W.	195 kgs / 227 kgs

*Specifications are subject to change without prior notice.

8.8" (220~225 mm)

BMT 275SHDK

- Manual Bandsaw / EURO Type -



Easily accessible control panel

*Machine shown with optional accessories

FEATURES:

- ◆ Swivel arm
- ◆ Quick handle locking vise
- ◆ Manual trigger control cutting
- ◆ Hydraulic flow control cutting
- ◆ Optional blade tension indicator gauge

MODEL	BMT 275SHDK
Capacity (90°)	● 225 mm, ■ 195 x 195 mm, ■ 245 x 120 mm
Capacity (45°)	● 150 mm, ■ 150 x 150 mm, ■ 200 x 135 mm
Capacity (60°)	● 90 mm, ■ 85 x 85 mm
Blade Size	27 x 0.9 x 2460 mm
Blade Speed	Vari. speed, 20~85 mpm
Blade Motor	2 HP
Packing Size	1505 x 685 x 930 mm
N.W. / G.W.	195 kgs / 227 kgs

*Specifications are subject to change without prior notice.

BMT 275W

- Manual Bandsaw / EURO Type -



*Machine shown with optional accessories

FEATURES:

- ◆ Swivel arm
- ◆ Coolant system
- ◆ Magnetic switch 24V & CE for BMT 245SL
- ◆ Hydraulic cylinder

MODEL	BMT 275W
Capacity (90°)	● 225 mm, ■ 190 x 190 mm, ■ 150 x 245 mm
Capacity (45°)	● 145 mm, ■ 150 x 150 mm, ■ 190 x 150 mm
Capacity (60°)	● 90 mm, ■ 90 x 90 mm, ■ 120 x 90 mm
Blade Size	27 x 0.9 x 2480 mm
Blade Speed	45 mpm, 90 mpm Vari. Speed, 20~90 mpm (opt.)
Blade Motor	1.5 HP / 2 HP (opt.)
Packing Size	1380 x 580 x 930 mm
N.W. / G.W.	200 kgs / 216 kgs
Container Loads	32 sets / 20'

*Specifications are subject to change without prior notice.

BMT 245SL / BMT 245SLA

- Manual Bandsaw / EURO Type -



*Machine shown with optional accessories

FEATURES:

- ◆ Swivel arm
- ◆ Coolant system
- ◆ Magnetic switch 24V & CE for BMT 245SL
- ◆ Hydraulic cylinder for BMT 245SLA
- ◆ Optional blade tension gauge

MODEL	BMT 245SL / BMT 245SLA
Capacity (90°)	● 225 mm, ■ 190 x 190 mm, ■ 150 x 245 mm
Capacity (45°)	● 145 mm, ■ 150 x 150 mm, ■ 190 x 150 mm
Capacity (60°)	● 90 mm, ■ 90 x 90 mm, ■ 120 x 90 mm
Blade Size	27 x 0.9 x 2480 mm
Blade Speed	45 mpm, 90 mpm Vari. speed, 20~90 mpm (opt.)
Blade Motor	1.5 HP / 2 HP (opt.)
Packing Size	1360 x 580 x 900 mm
N.W. / G.W.	185 kgs / 200 kgs
Container Loads	32 sets / 20'

*Specifications are subject to change without prior notice.

BMT 260

- Manual Bandsaw / EURO Type -



*Machine shown with optional accessories

FEATURES:

- ◆ Swivel arm
- ◆ Coolant system
- ◆ Magnetic switch 24V & CE
- ◆ Blade tension gauge
- ◆ Optional hydraulic cylinder

MODEL	BMT 260
Capacity (90°)	● 225 mm, ■ 200 x 200 mm, ■ 150 x 235 mm
Capacity (45°)	● 150 mm, ■ 150 x 150 mm, ■ 210 x 140 mm
Capacity (60°)	● 90 mm, ■ 90 x 90 mm, ■ 105 x 90 mm
Blade Size	27 x 0.9 x 2480 mm
Blade Speed	45 mpm, 90 mpm / Vari. speed, 20~90 mpm (opt.)
Blade Motor	1.5 HP / 2 HP (opt.)
Packing Size	1460 x 730 x 1060 mm
N.W. / G.W.	265 kgs / 285 kgs
Container Loads	24 sets / 20'

*Specifications are subject to change without prior notice.

8.8" (220~225 mm)

BMT 260N

- Manual Bandsaw / EURO Type -



Easily accessible control panel

*Machine shown with optional accessories

FEATURES:

- ◆ Swivel arm
- ◆ Coolant system
- ◆ Magnetic switch 24V & CE
- ◆ Blade tension gauge
- ◆ Hydraulic cylinder

MODEL	BMT 260N
Capacity (90°)	● 225 mm, ■ 200 x 200 mm, ■ 150 x 235 mm
Capacity (45°)	● 150 mm, ■ 150 x 150 mm, ■ 200 x 150 mm
Capacity (60°)	● 90 mm, ■ 90 x 90 mm, ■ 105 x 90 mm
Blade Size	27 x 0.9 x 2480 mm
Blade Speed	45 mpm, 90 mpm / Vari. speed, 20~90 mpm (opt.)
Blade Motor	1.5 HP / 2 HP (opt.)
Packing Size	1520 x 570 x 910 mm
N.W. / G.W.	225 kgs / 240 kgs
Container Loads	16 sets / 20'

*Specifications are subject to change without prior notice.

BMT 220

- Manual Bandsaw / US Type -



*Machine shown with optional accessories

FEATURES:

- ◆ Swivel arm
- ◆ Coolant system
- ◆ Inverter
- ◆ Blade tension gauge
- ◆ Hydraulic cylinder

MODEL	BMT 220
Capacity (90°)	● 225 mm, ■ 225 x 225 mm, ■ 160 x 310 mm
Capacity (45°)	● 155 mm, ■ 155 x 155 mm, ■ 210 x 155 mm
Blade Size	27 x 0.9 x 2480 mm
Blade Speed	45 mpm, 90 mpm Vari. speed, 20~90 mpm (opt.)
Blade Motor	1.5 HP / 2 HP (opt.)
Packing Size	1470 x 490 x 1120 mm
N.W. / G.W.	180 kgs / 195 kgs
Container Loads	32 sets / 20'

*Specifications are subject to change without prior notice.

BMT 280W

- Manual Bandsaw / EURO Type -



*Machine shown with optional accessories

FEATURES:

- ◆ Swivel arm
- ◆ Coolant system
- ◆ Magnetic switch 24V & CE
- ◆ Blade tension gauge
- ◆ Hydraulic cylinder

MODEL	BMT 280W
Capacity (90°)	● 225 mm, ■ 180 x 180 mm, ■ 150 x 245 mm
Capacity (45°)	● 145 mm, ■ 145 x 145 mm, ■ 190 x 150 mm
Capacity (60°)	● 90 mm, ■ 90 x 90 mm, ■ 115 x 90 mm
Capacity (L45°)	● 120 mm, ■ 120 x 120 mm, ■ 150 x 120 mm
Blade Size	27 x 0.9 x 2750 mm
Blade Speed	45 mpm, 90 mpm Vari. speed, 20~90 mpm (opt.)
Blade Motor	1.5 HP / 2 HP (opt.)
Packing Size	1460 x 720 x 1410 mm
N.W. / G.W.	295 kgs / 315 kgs
Container Loads	8 sets / 20'

*Specifications are subject to change without prior notice.

BMT 916A / BMT 916V

- Manual Bandsaw / US Type -



*Machine shown with optional accessories

FEATURES:

- ◆ Swivel vise
- ◆ 4 step pulley for BMT 916A
- ◆ Variable speeds for BMT 916V
- ◆ Coolant pump
- ◆ Removable chip tray

MODEL	BMT 916A	BMT 916V
Capacity (90°)	● 225 mm, ■ 225 x 345 mm, ■ 35 x 400 mm	
Capacity (45°)	● 165 mm, ■ 225 x 165 mm	
Blade Size	27 x 0.9 x 3035 mm	
Blade Speed	4 steps, 25/40/51/71 mpm	Vari. speed, 25~75 mpm
Blade Motor	1.5 HP	
Packing Size	1727 x 749 x 1092 mm	1803 x 749 x 1092 mm
N.W. / G.W.	285 kgs / 320 kgs	
Container Loads	26 sets / 20', 54 sets / 40'	18 sets / 20', 38 sets / 40'

*Specifications are subject to change without prior notice.

8.8" (220~225 mm)

BMT 918S

- Manual Bandsaw / US Type -



*Machine shown with optional accessories

FEATURES:

- ◆ Swivel arm
- ◆ Coolant system

MODEL	BMT 918S
Capacity (90°)	● 225 mm, ■ 225 x 430 mm, ■ 150 x 450 mm
Capacity (45°)	● 225 mm, ■ 225 x 295 mm
Blade Size	27 x 0.9 x 3345 mm
Blade Speed	Vari. speed, 25~75 mpm
Blade Motor	2 HP
Packing Size	1931 x 750 x 1080 mm
N.W. / G.W.	420 kgs / 485 kgs
Container Loads	18 sets / 20', 38 sets / 40'

*Specifications are subject to change without prior notice.

BMT 918SSA

- Semi-automatic Bandsaw / US Type -

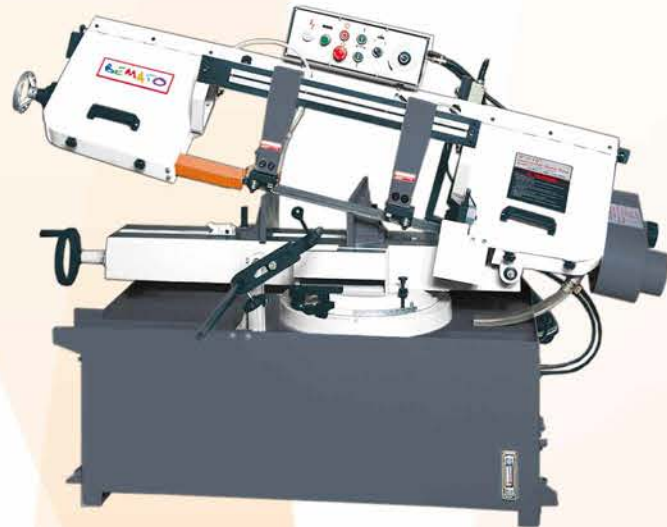

*Machine shown with optional accessories

FEATURES:

- ◆ Swivel arm
- ◆ Coolant system

MODEL	BMT 918SSA
Capacity (90°)	● 225 mm, ■ 225 x 430 mm, ■ 150 x 450 mm
Capacity (45°)	● 225 mm, ■ 225 x 295 mm
Blade Size	27 x 0.9 x 3345 mm
Blade Speed	Vari. speed, 25~75 mpm
Blade Motor	2 HP
Packing Size	1930 x 750 x 1080 mm
N.W. / G.W.	480 kgs / 550 kgs
Container Loads	18 sets / 20', 38 sets / 40'

*Specifications are subject to change without prior notice.

9" (227~230 mm)

BMT 260SLHI

- Manual Bandsaw / EURO Type -



*Machine shown with optional accessories

FEATURES:

- ◆ Swivel arm
- ◆ Coolant system
- ◆ Inverter control blade speed
- ◆ Trigger switch
- ◆ Quickly lock handle
- ◆ Hydraulic cylinder

MODEL	BMT 260SLHI
Capacity (90°)	● 227 mm, ■ 220 x 220 mm, ■ 110 x 260 mm
Capacity (45°)	● 150 mm, ■ 145 x 145 mm, ■ 125 x 200 mm
Capacity (60°)	● 90 mm, ■ 85 x 85 mm
Blade Size	27 x 0.9 x 2460 mm
Blade Speed	Vari. speed (inverter), 20~85 mpm
Blade Motor	1.5 HP
Packing Size	1549 x 737 x 921 mm
N.W. / G.W.	216 kgs / 250 kgs
Container Loads	22 sets / 20', 46 sets / 40'

*Specifications are subject to change without prior notice.

BMT 260SSA

- Semi-automatic Bandsaw / EURO Type -



*Machine shown with optional accessories

FEATURES:

- ◆ Dual angle vise
- ◆ Hydraulic automatic clamping vise
- ◆ Blade tension gauge

MODEL	BMT 260SSA
Capacity (90°)	● 227 mm, ■ 220 x 220 mm, ■ 110 x 20 mm
Capacity (45°)	● 150 mm, ■ 145 x 145 mm, ■ 125 x 200 mm
Capacity (60°)	● 90 mm, ■ 85 x 85 mm
Capacity (L45°)	● 110 mm, ■ 110 x 110 mm, ■ 110 x 160 mm
Blade Size	27 x 0.9 x 2460 mm
Blade Speed	4P: 72 mpm, 8P: 36 mpm @ 50Hz
Blade Motor	1.5 HP
Coolant Motor, Tank	1/20 HP
Packing Size	1575 x 737 x 1575 mm
N.W. / G.W.	380 kgs / 450 kgs
Container Loads	11 sets / 20', 22 sets / 40'

*Specifications are subject to change without prior notice.

9" (227~230 mm)

BMT 275DSAI

- Semi-automatic Bandsaw / EURO Type -



*Machine shown with optional accessories

FEATURES:

- ◆ Dual miter cutting
- ◆ Inverter controls blade speed
- ◆ Hydraulic flow control cutting valve
- ◆ Blade tension gauge
- ◆ Blade broken detecting switch

MODEL	BMT 275DSAI
Capacity (90°)	● 227 mm, ■ 220 x 220 mm, ■ 110 x 260 mm
Capacity (45°)	● 150 mm, ■ 145 x 145 mm, ■ 125 x 200 mm
Capacity (60°)	● 90 mm, ■ 85 x 85 mm
Capacity (L45°)	● 110 mm, ■ 110 x 110 mm, ■ 110 x 160 mm
Blade Size	27 x 0.9 x 2460 mm
Blade Speed	Vari. speed (inverter), 20~85 mpm
Blade Motor	1.5 HP
Coolant Motor	1/20 HP
Packing Size	1549 x 737 x 1054 mm
N.W. / G.W.	315 kgs / 360 kgs
Container Loads	22 sets / 20', 46 sets / 40'

*Specifications are subject to change without prior notice.

BMT 912B / BMT 912G

- Manual Bandsaw / US Type -



*Machine shown with optional accessories

FEATURES:

- ◆ 9" step pulley for BMT 912B
- ◆ 9" geared drive for BMT 912G
- ◆ Tru-lock vise (Patent No. 142715)

MODEL	BMT 912B	BMT 912G
Capacity (90°)	● 229 mm, ■ 200 x 305 mm	● 229 mm, ■ 178 x 305 mm
Capacity (45°)	● 150 mm, ■ 127 x 150 mm	
Blade Size	27 x 0.9 x 2655 mm	
Blade Speed	4 steps 32/60/88/115 mpm @ 60 Hz 26/50/73/95 mpm @ 50 Hz	3 steps 45/66/86 mpm @ 60 Hz 38/55/72 mpm @ 50 Hz
Blade Motor	1 HP	
Packing Size	1140 x 510 x 1125 mm	1473 x 508 x 1270 mm
N.W. / G.W.	160 kgs / 185 kgs	175 kgs / 205 kgs
Container Loads	30 sets / 20'	14 sets / 20'

*Specifications are subject to change without prior notice.

BMT 916S / BMT 916SV

- Manual Bandsaw / US Type -



*Machine shown with optional accessories

FEATURES:

- ◆ 9" step pulley for BMT 916S
- ◆ Variable speed for BMT 916SV
- ◆ Optional hydraulic blade tension gauge

MODEL	BMT 916S	BMT 916SV
Capacity (90°)	● 229 mm, ■ 406 x 127 mm	
Capacity (45°)	● 229 mm, ■ 241 x 203 mm	
Blade Size	27 x 0.9 x 2910 mm	
Blade Speed	4 steps 35/60/88/115 mpm @ 60 Hz	Vari. speed, 22~95 mpm
Blade Motor	1.5 HP	
Packing Size	1700 x 625 x 1235 mm	
N.W. / G.W.	280 kgs / 310 kgs	
Container Loads	18 sets / 20'	

*Specifications are subject to change without prior notice.

9" (227~230 mm)

BMT 916M / BMT 916MV

- Manual Bandsaw / US Type -



*Machine shown with optional accessories

FEATURES:

- ◆ Swivel vise
- ◆ Coolant system
- ◆ Optional automatic saw blade breakage power off system
- ◆ Optional blade tension gauge
- ◆ Optional roller table

MODEL	BMT 916M / BMT 916MV
Capacity (90°)	● 230 mm, ■ 230 x 230 mm, ■ 150 x 400 mm
Capacity (45°)	● 180 mm, ■ 180 x 180 mm, ■ 180 x 220 mm
Blade Size	27 x 0.9 x 3265 mm
Blade Speed	4 steps, 15/38/61/84 mpm
Blade Motor	2 HP
Packing Size	1820 x 750 x 1060 mm
N.W. / G.W.	280 kgs / 330 kgs

*Specifications are subject to change without prior notice.

BMT 916SA

- Semi-automatic Bandsaw / US Type -



*Machine shown with optional accessories

FEATURES:

- ◆ Swivel vise
- ◆ Coolant system
- ◆ Optional automatic saw blade breakage power off system
- ◆ Optional blade tension gauge
- ◆ Optional roller table

MODEL	BMT 916SA
Capacity (90°)	● 230 mm, ■ 230 x 230 mm, ■ 150 x 400 mm
Capacity (45°)	● 180 mm, ■ 180 x 180 mm, ■ 180 x 220 mm
Blade Size	27 x 0.9 x 3265 mm
Blade Speed	4 steps, 15~84 mpm
Blade Motor	2 HP
Packing Size	1820 x 750 x 1060 mm
N.W. / G.W.	300 kgs / 350 kgs

*Specifications are subject to change without prior notice.

9.5" (240 mm)

BMT 285YM / BMT 285YC

- Manual Bandsaw / EURO Type for BMT 285YM -
- Semi-automatic Bandsaw / EURO Type for BMT 285YC -



*Machine shown with optional accessories

FEATURES:

- ◆ Swivel arm
- ◆ Quick clamping vise
- ◆ Blade tension adjustment from the front
- ◆ Coolant system
- ◆ Blade guides with hard metal pads

MODEL	BMT 285YM / BMT 285YC
Capacity (90°)	● 240 mm, ■ 240 x 240 mm, ■ 240 x 270 mm
Capacity (45°)	● 160 mm, ■ 150 x 150 mm
Capacity (L45°)	● 200 mm, ■ 200 x 200 mm
Capacity (L60°)	● 125 mm, ■ 125 x 125 mm
Blade Size	27 x 0.9 x 2730 mm
Blade Speed	35 mpm, 70 mpm
Blade Motor	1.5 HP
Packing Size	1385 x 745 x 935 mm
N.W. / G.W.	260 kgs / 290 kgs
Container Loads	24 sets / 20'

*Specifications are subject to change without prior notice.

BMT 310RK / BMT 310ARK / BMT 310ARKV

- Manual Bandsaw / EURO Type for BMT 310RK -
- Semi-automatic Bandsaw / EURO Type for BMT 310ARK / BMT 310ARKV -



*Machine shown with optional accessories

FEATURES:

- ◆ Dual miter cutting
- ◆ Blade tension gauge
- ◆ Saw blade breakage switch
- ◆ Manual vise clamping for BMT 310RK
- ◆ Inverter driven variable speed for BMT 310ATKV
- ◆ Hydraulic vise clamping for BMT 310ARK, BMT 310ARKV

MODEL	BMT 310RK / BMT 310ARK / BMT 310ARKV
Capacity (90°)	● 240 mm, ■ 240 x 240 mm, ■ 160 x 310 mm
Capacity (R45°)	● 200 mm, ■ 180 x 180 mm, ■ 90 x 195 mm
Capacity (L45°)	● 160 mm, ■ 140 x 140 mm, ■ 90 x 170 mm
Capacity (60°)	● 120 mm, ■ 80 x 80 mm
Blade Size	27 x 0.9 x 2725 mm
Blade Speed	4P: 72 mpm, 8P: 36 mpm for BMT 310RK Vari. speed (inverter), 20~85 mpm for BMT 310ARK / BMT 310ARKV
Blade Motor	1.5 HP / 50 HZ
Hydraulic Motor	1/2 HP
Coolant Motor	32W
Container Loads	10 units / 20', 20 units / 40'
Packing Size	1702 x 749 x 1575 mm
N.W. / G.W.	430 kgs / 490 kgs

*Specifications are subject to change without prior notice.

10" (250 mm)

BMT 285DSAG / BMT 285DSAGV

- Semi-automatic Bandsaw -



*Machine shown with optional accessories

BMT 310DSAG / BMT 310DSAGV

- Semi-automatic Bandsaw -



FEATURES:

- ◆ Sliding vise base
- ◆ Swiveling control box (for BMT 310DSAGV)
- ◆ Motor inverter controlled blade speed to provide a high efficiency and variable speed conversion (for BMT 310DSAGV)

FEATURES:

- ◆ Dovetail working table
- ◆ Aluminum gear reducer
- ◆ Swiveling control box (for BMT 285DSAGV)
- ◆ Motor inverter controlled blade speed (for BMT 285DSAGV)

MODEL	BMT 285DSAG / BMT 285DSAGV
Capacity (90°)	● 250 mm, ■ 250 x 250 mm, ■ 240 x 285 mm
Capacity (45°)	● 190 mm, ■ 180 x 180 mm, ■ 140 x 190 mm
Capacity (60°)	● 120mm, ■ 100 x 100 mm, ■ 100 x 120 mm
Capacity (L45°)	● 180 mm, ■ 150 x 150 mm, ■ 50 x 200 mm
Blade Size	27 x 0.9 x 2685 mm
Blade Speed	4P: 72 mpm, 8P: 36 mpm @ 50 Hz Vari. speed (Inverter), 20~85 mpm for BMT 285DSAGV
Blade Motor	1.5 HP
Coolant Motor	1/25 HP
Packing Size	1835 x 775 x 1650 mm
N.W. / G.W.	310 kgs / 360 kgs
Container Loads	9 sets / 20', 18 sets / 40'

*Specifications are subject to change without prior notice.

MODEL	BMT 310DSAG / BMT 310DSAGV
Capacity (90°)	● 240 mm, ■ 235 x 235 mm, ■ 165 x 310 mm
Capacity (45°)	● 195 mm, ■ 185 x 185 mm, ■ 130 x 195 mm
Capacity (60°)	● 120mm, ■ 85 x 85 mm, ■ 90 x 120 mm
Capacity (L45°)	● 165 mm, ■ 140 x 140 mm, ■ 60 x 195 mm
Blade Size	27 x 0.9 x 2725 mm
Blade Speed	4P: 72 mpm, 8P: 36 mpm @ 50 Hz Vari. speed (Inverter), 20~85 mpm for BMT 310DSAGV
Blade Motor	1.5 HP
Coolant Motor	0.06 HP
Packing Size	1835 x 775 x 1650 mm
N.W. / G.W.	310 kgs / 360 kgs
Container Loads	9 sets / 20', 18 sets / 40'

*Specifications are subject to change without prior notice.

BMT 310SSA

- Semi-automatic Bandsaw / EURO Type -



*Machine shown with optional accessories

FEATURES:

- ◆ Dual angle vise
- ◆ Blade tension gauge
- ◆ Saw blade breakage detecting switch

BMT 310SSAI

- Semi-automatic Bandsaw / EURO Type -



FEATURES:

- ◆ Dual miter cutting
- ◆ Blade tension gauge
- ◆ Saw blade breakage detecting switch
- ◆ Inverter controls blade speed

MODEL	BMT 310SSA / BMT 310SSAI
Capacity (90°)	● 250 mm, ■ 240 x 240 mm, ■ 310 x 210 mm
Capacity (45°)	● 200 mm, ■ 180 x 180 mm, ■ 200 x 140 mm
Capacity (60°)	● 120 mm, ■ 95 x 95 mm, ■ 120 x 95 mm
Capacity (L45°)	● 150 mm, ■ 150 x 150 mm, ■ 90 x 170 mm
Blade Size	27 x 0.9 x 2725 mm
Blade Speed	4P: 72 mpm, 8P: 36 mpm @ 50 Hz Vari. speed (inverter), 20~85 mpm for BMT 310SSAI
Blade Motor	1.5 HP
Packing Size	1702 x 749 x 1575 mm
N.W. / G.W.	410 kgs / 480 kgs
Container Loads	10 sets / 20', 20 sets / 40'

*Specifications are subject to change without prior notice.

10" (250 mm)

BMT 310AR / BMT 310ARI

- Semi-automatic Bandsaw / EURO Type -



*Machine shown with optional accessories

FEATURES:

- ◆ Dual miter cutting
- ◆ Blade tension gauge
- ◆ Saw blade breakage detecting switch
- ◆ Hydraulic vise & hydraulic cylinder

MODEL	BMT 310AR / BMT 310ARI
Capacity (90°)	● 250 mm, ■ 240 x 240 mm, ■ 210 x 310 mm
Capacity (45°)	● 200 mm, ■ 180 x 180 mm, ■ 200 x 140 mm
Capacity (60°)	● 120 mm, ■ 120 x 120 mm
Capacity (L45°)	● 150 mm, ■ 150 x 150 mm, ■ 210 x 75 mm
Blade Size	27 x 0.9 x 2725 mm
Blade Speed	4P: 72 mpm, 8P: 36 mpm @ 50Hz Vari. speed, 20~85 mpm for BMT 310ARI
Blade Motor	1.5 HP
Hydraulic Motor	1/2 HP
Coolant Motor	1/20 HP
Packing Size	1702 x 749 x 1575 mm
N.W. / G.W.	430 kgs / 490 kgs
Container Loads	10 sets / 20', 20 sets / 40'

BMT 250V

- Manual Bandsaw / US Type -



FEATURES:

- ◆ Swivel arm
- ◆ Coolant pump
- ◆ Variable speed

MODEL	BMT 250V
Capacity (90°)	● 250 mm, ■ 250 x 415 mm, ■ 200 x 450 mm
Capacity (45°)	● 190 mm, ■ 250 x 190 mm
Blade Size	27 x 0.9 x 3300 mm
Blade Speed	Vari. speed, 25~75 mpm
Blade Motor	2 HP
Packing Size	1880 x 750 x 1117 mm
N.W. / G.W.	320 kgs / 360 kgs
Container Loads	14 sets / 20'

*Specifications are subject to change without prior notice.

BMT 250HSSA

- Semi-automatic Bandsaw / US Type -



*Machine shown with optional accessories

FEATURES:

- ◆ Swivel arm
- ◆ Coolant pump
- ◆ Hydraulic vise
- ◆ Swiveling control box

MODEL	BMT 250HSSA
Capacity (90°)	● 250 mm, ■ 250 x 385 mm, ■ 230 x 400 mm
Capacity (45°)	● 215 mm, ■ 250 x 215 mm
Blade Size	27 x 0.9 x 3300 mm
Blade Speed	Vari. speed, 25~75 mpm
Blade Motor	2 HP
Packing Size	1905 x 775 x 1117 mm
N.W. / G.W.	500 kgs / 565 kgs
Container Loads	14 sets / 20'

*Specifications are subject to change without prior notice.

BMT 250FA

- Fully Automatic Bandsaw / US Type -



FEATURES:

- ◆ Color touchscreen
- ◆ 10 cutting job preset memory
- ◆ Hydraulic blade tension device
- ◆ Automatic chip conveyor
- ◆ Precise length encoder
- ◆ Inverter variable speed

MODEL	BMT 250FA
Capacity (90°)	● 250 mm, ■ 250 x 300 mm
Blade Size	27 x 0.9 x 3505 mm
Blade Speed	Vari. speed (inverter), 30~85 mpm
Blade Motor	3 HP
Hydraulic Motor, Tank	1 HP, 30 L
Coolant Motor, Tank	1/6 HP, 40 L
Bundle Cutting (H x W)	150~250 x 100~130 mm
Cut Off Length	over 10 mm
Feeding Stroke	400 mm
Minimum No Material Detecting	32 mm
Minimum Residual Work Length	110 mm
Table Height	750 mm
Packing Size	2210 x 2290 x 1890 mm
N.W. / G.W.	1430 kgs / 1690 kgs

*Specifications are subject to change without prior notice.

10" (254~255 mm)

BMT 1018S / BMT 1018SV

- Manual Bandsaw / US Type -



*Machine shown with optional accessories

FEATURES:

- ◆ Swivel arm
- ◆ 10" step pulley for BMT 1018S
- ◆ Variable speed for BMT 1018SV
- ◆ Tru-lock vise

MODEL	BMT 1018S / BMT 1018SV
Capacity (90°)	● 254 mm, ■ 127 x 468 mm
Capacity (45°)	● 150 mm, ■ 175 x 239 mm
Blade Size	27 x 0.9 x 3090 mm
Blade Speed	4 steps 35/60/88/115 mpm @ 60 Hz 29/50/73/96 mpm @ 50 Hz Vari. speed, 22~95 mpm for BMT 1018SV
Blade Motor	2 HP
Packing Size	1790 x 670 x 1155 mm
N.W. / G.W.	320 kgs / 350 kgs
Container Loads	9 sets / 20'

*Specifications are subject to change without prior notice.

BMT 1018R / BMT 1018RV

- Manual Bandsaw / US Type -



*Machine shown with optional accessories

FEATURES:

- ◆ Swivel base
- ◆ Variable speed for BMT 1018RV
- ◆ Optional blade tension gauge

MODEL	BMT 1018R / BMT 1018RV
Capacity (90°)	● 254 mm, ■ 254 x 385 mm, ■ 254 x 400 mm
Capacity (45°)	● 200 mm, ■ 200 x 200 mm
Blade Size	27 x 0.9 x 3090 mm
Blade Speed	4 steps, 30/60/88/115 mpm @ 60 Hz Vari. speed, 30~110 mpm for BMT 1018RV
Blade Motor	2 HP
Packing Size	1730 x 830 x 1160 mm
N.W. / G.W.	390 kgs / 430 kgs
Container Loads	7 sets / 20', 14 sets / 40'

*Specifications are subject to change without prior notice.

BMT 300

- Manual Bandsaw / EURO Type -

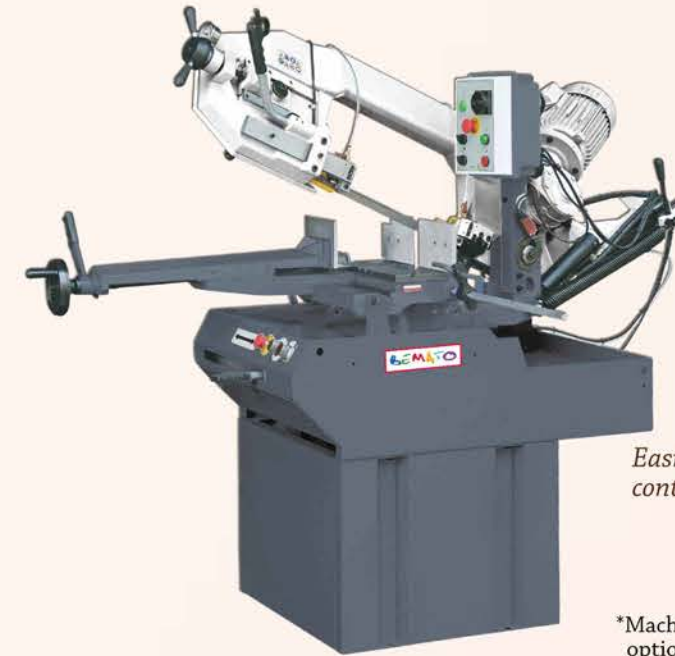

Easily accessible control panel

*Machine shown with optional accessories

FEATURES:

- ◆ Dual miter cutting
- ◆ Coolant pump
- ◆ Hydraulic cylinder
- ◆ Blade tension gauge
- ◆ Magnetic switch 24V & CE

MODEL	BMT 300	BMT 300N
Capacity (90°)	● 255 mm, ■ 200 x 200 mm, ■ 200 x 320 mm	
Capacity (45°)	● 195 mm, ■ 195 x 195 mm, ■ 195 mm	
Capacity (60°)	● 125 mm, ■ 125 x 125 mm, ■ 130 x 120 mm	
Capacity (L45°)	● 200 mm, ■ 170 x 170 mm, ■ 200 x 170 mm	
Blade Size	27 x 0.9 x 2750 mm	
Blade Speed	35 mpm, 70 mpm / Inverter, 20~80 mpm (opt.)	
Blade Motor	2 HP / 2 HP (opt.)	
Packing Size	1720 x 730 x 1130 mm	1730 x 770 x 1100 mm
N.W. / G.W.	335 kgs / 371 kgs	350 kgs / 390 kgs
Container Loads	16 sets / 20'	

*Specifications are subject to change without prior notice.

BMT 300N

- Manual Bandsaw / EURO Type -



FEATURES:

- ◆ Dual miter cutting
- ◆ Coolant pump
- ◆ Hydraulic cylinder
- ◆ Blade tension gauge
- ◆ Optional inverter variable speed

10" (254~255 mm)

BMT 300RC

- Manual Bandsaw / EURO Type -



BMT 300RN

- Manual Bandsaw / EURO Type -



Easily accessible control panel

*Machine shown with optional accessories

FEATURES:

- ◆ Dual miter cutting
- ◆ Coolant pump
- ◆ Hydraulic cylinder
- ◆ Blade tension gauge
- ◆ Magnetic switch 24V & CE
- ◆ Round table

FEATURES:

- ◆ Dual miter cutting
- ◆ Coolant pump
- ◆ Hydraulic cylinder
- ◆ Blade tension gauge
- ◆ Magnetic switch 24V & CE
- ◆ Round table

MODEL	BMT 300RC	BMT 300RN
Capacity (90°)	● 255 mm, ■ 255 x 255 mm, ▨ 160 x 310 mm	
Capacity (45°)	● 185 mm, ■ 180 x 180 mm, ▨ 230 x 170 mm	
Capacity (60°)	● 115 mm, ■ 115 x 115 mm, ▨ 160 x 115 mm	
Capacity (L45°)	● 180 mm, ■ 170 x 170 mm, ▨ 220 x 140 mm	
Blade Size	27 x 0.9 x 2750 mm	
Blade Speed	35 mpm, 70 mpm / Inverter, 20~80 mpm (opt.)	
Blade Motor	2 HP / 2HP (opt.)	
Packing Size	1720 x 730 x 1130 mm	1730 x 730 x 1100 mm
N.W. / G.W.	380 kgs / 426 kgs	385 kgs / 425 kgs
Container Loads	16 sets / 20'	

*Specifications are subject to change without prior notice.

BMT 300RNT

- Semi-Automatic Bandsaw / EURO Type -



FEATURES:

- ◆ Dual miter cutting
- ◆ Coolant pump
- ◆ Hydraulic cylinder
- ◆ Blade tension gauge
- ◆ Magnetic switch 24V & CE
- ◆ Round table
- ◆ Hydraulic clamp vise
- ◆ New one piece solid stand
- ◆ Easy lift saw bow cover design
- ◆ Optional inverter variable speed

MODEL	BMT 300RNT
Capacity (90°)	● 255 mm, ■ 255 x 255 mm, ▨ 160 x 310 mm
Capacity (45°)	● 185 mm, ■ 180 x 180 mm, ▨ 230 x 170 mm
Capacity (60°)	● 115 mm, ■ 115 x 115 mm, ▨ 160 x 115 mm
Capacity (L45°)	● 180 mm, ■ 170 x 170 mm, ▨ 220 x 140 mm
Blade Size	27 x 0.9 x 2750 mm
Blade Speed	35/70 mpm
Blade Motor	Inverter, 20~80 mpm (opt.)
Motor	2 HP / 3 HP (opt.)
Packing Size	1730 x 730 x 1550 mm
N.W. / G.W.	498 kgs / 540 kgs

*Specifications are subject to change without prior notice.

BMT 300W

- Manual Bandsaw / EURO Type -



*Machine shown with optional accessories

FEATURES:

- ◆ Dual miter cutting
- ◆ Coolant pump
- ◆ Hydraulic cylinder
- ◆ Blade tension gauge
- ◆ Magnetic switch 24V & CE
- ◆ Optional inverter variable speed

MODEL	BMT 300W
Capacity (90°)	● 255 mm, ■ 200 x 200 mm, ▨ 200 x 320 mm
Capacity (45°)	● 195 mm, ■ 195 x 195 mm, ▨ 195 x 195 mm
Capacity (60°)	● 125 mm, ■ 125 x 125 mm, ▨ 130 x 120 mm
Capacity (L45°)	● 200 mm, ■ 170 x 170 mm, ▨ 200 x 170 mm
Blade Size	27 x 0.9 x 2750 mm
Blade Speed	35/70 mpm
Blade Motor	Inverter, 20~80 mpm (opt.)
Blade Motor	2 HP / 2 HP (opt.)
Packing Size	1730 x 720 x 1410 mm
N.W. / G.W.	335 kgs / 371 kgs
Container Loads	8 sets / 20'

*Specifications are subject to change without prior notice.

10" (254~255 mm)

BMT 1018SRV

- Semi-Automatic Bandsaw / US Type -



*Machine shown with optional accessories

FEATURES:

- ◆ Swivel base
- ◆ Variable speed
- ◆ Tru-lock vise
- ◆ Optional hydraulic blade tension gauge

MODEL	BMT 1018SRV
Capacity (90°)	● 254 mm, ■ 254 x 430 mm
Capacity (45°)	● 240 mm, ■ 220 x 240 mm
Blade Size	27 x 0.9 x 3090 mm
Blade Speed	Vari. speed, 22~95 mpm
Blade Motor	2 HP
Packing Size	1790 x 740 x 1145 mm
N.W. / G.W.	380 kgs / 420 kgs
Container Loads	9 sets / 20'

*Specifications are subject to change without prior notice.

BMT 1018RVAA

- Semi-Automatic Bandsaw / US Type -



*Machine shown with optional accessories

FEATURES:

- ◆ Swivel base
- ◆ Variable speed
- ◆ Hydraulic vise
- ◆ Optional hydraulic blade tension gauge

MODEL	BMT 1018RVAA
Capacity (90°)	● 254 mm, ■ 254 x 385 mm, ■ 254 x 400 mm
Capacity (45°)	● 200 mm, ■ 200 x 200 mm
Blade Size	27 x 0.9 x 3090 mm
Blade Speed	Vari. speed, 30~110 mpm
Blade Motor	2 HP
Packing Size	1730 x 830 x 1160 mm
N.W. / G.W.	420 kgs / 470 kgs
Container Loads	7 sets / 20', 14 sets / 40'

*Specifications are subject to change without prior notice.

BMT 250SR

- Semi-Automatic Bandsaw / US Type -



*Machine shown with optional accessories

FEATURES:

- ◆ Dual miter cutting
- ◆ Variable speed
- ◆ Optional hydraulic blade tension gauge

BMT 250N / BMT 250AR / BMT 250ARA

- Manual Bandsaw / US Type for BMT 250N -
- Semi-Automatic Bandsaw / US Type for BMT 250AR & BMT 250ARA -



FEATURES:

- ◆ Dual miter cutting
- ◆ Variable speed
- ◆ Hydraulic saw arm lifting for BMT 250AR & BMT 250ARA
- ◆ Hydraulic vise for BMT 250ARA
- ◆ Optional hydraulic blade tension gauge

MODEL	BMT 250SR	BMT 250N	BMT 250AR / BMT 250ARA
Capacity (90°)	● 254 mm, ■ 254 x 254 mm, ■ 76 x 458 mm		
Capacity (45°)	● 254 mm, ■ 254 x 254 mm, ■ 254 x 280 mm		
Capacity (L45°)	● 254 mm, ■ 254 x 254 mm, ■ 254 x 280 mm		
Capacity (L60°)	● 204 mm, ■ 178 x 178 mm, ■ 127 x 204 mm		
Blade Size	27 x 0.9 x 3352 mm		
Blade Speed	Vari. speed, 30~120 mpm		
Blade Motor	2 HP		
Packing Size	2004 x 917 x 1207 mm	1994 x 944 x 1507 mm	1900 x 940 x 1460 mm
N.W. / G.W.	420 kgs / 460 kgs	530 kgs / 570 kgs	580 kgs / 630 kgs
Container Loads	12 sets / 20'	6 sets / 20'	

*Specifications are subject to change without prior notice.

10.5" (260~270 mm)

BMT 300YM / BMT 300AY

- Manual Bandsaw / EURO Type for BMT 300YM -
- Semi-Automatic Bandsaw / EURO Type for BMT 300AY -



*Machine shown with optional accessories

FEATURES:

- ◆ Dual miter cutting
- ◆ Quick clamping vise
- ◆ Blade tension adjustment from the front
- ◆ Bearing turning system (BTS)
- ◆ Movable chips tank

MODEL	BMT 300YM / BMT 300AY
Capacity (90°)	● 260 mm, ■ 255 x 255 mm, ■ 295 x 230 mm
Capacity (45°)	● 190 mm, ■ 190 x 190 mm
Capacity (L45°)	● 240 mm, ■ 215 x 215 mm, ■ 225 x 215 mm
Capacity (L60°)	● 160 mm, ■ 130 x 130 mm, ■ 160 x 130 mm
Blade Size	27 x 0.9 x 2965 mm
Blade Speed	37 mpm, 76 mpm
Blade Motor	1.6 HP
Packing Size	1580 x 760 x 1700 mm
N.W. / G.W.	310 kgs / 340 kgs
Container Loads	22 sets / 20'

*Specifications are subject to change without prior notice.

BMT 300YSA

- Semi-Automatic Bandsaw / EURO Type -



*Machine shown with optional accessories

FEATURES:

- ◆ Dual miter cutting
- ◆ Hydraulic vise with adjustable guides
- ◆ Blade tension adjustment from the front
- ◆ Bearing turning system (BTS)
- ◆ Movable chips tank

MODEL	BMT 300YSA
Capacity (90°)	● 260 mm, ■ 255 x 255 mm, ■ 295 x 230 mm
Capacity (45°)	● 190 mm, ■ 190 x 190 mm
Capacity (L45°)	● 240 mm, ■ 215 x 215 mm, ■ 225 x 215 mm
Capacity (L60°)	● 160 mm, ■ 130 x 130 mm, ■ 160 x 130 mm
Blade Size	27 x 0.9 x 2965 mm
Blade Speed	37 mpm, 76 mpm
Blade Motor	1.6 HP
Packing Size	1590 x 760 x 1700 mm
N.W. / G.W.	310 kgs / 341 kgs
Container Loads	12 sets / 20'

*Specifications are subject to change without prior notice.

BMT 300CNC

- Fully Automatic Bandsaw / EURO Type -



*Machine shown with optional accessories

FEATURES:

- ◆ Dual miter cutting
- ◆ Hydraulic feeder vise
- ◆ Cast iron sawframe
- ◆ Feed down speed control
- ◆ Bunch cutting
- ◆ Control panel with color touch screen
- ◆ Blade tension adjustment from the front
- ◆ Water spray gun for cleaning
- ◆ Ball-screw
- ◆ Moveable chip tank

MODEL	BMT 300CNC
Capacity (90°)	● 260 mm, ■ 255 x 255 mm, ■ 295 x 230 mm
Capacity (45°)	● 190 mm, ■ 190 x 190 mm
Capacity (L45°)	● 240 mm, ■ 215 x 215 mm, ■ 225 x 215 mm
Capacity (L60°)	● 160 mm, ■ 130 x 130 mm, ■ 160 x 130 mm
Blade Size	27 x 0.9 x 2965 mm
Blade Speed	Vari. Speed (inverter), 25~85 mpm
Blade Motor	1.6 HP
Packing Size	1800 x 1300 x 1600 mm
N.W. / G.W.	580 kgs / 650 kgs
Container Loads	4 sets / 20'

*Specifications are subject to change without prior notice.

10.5" (260~270 mm)

BMT 350R

- Manual Bandsaw / EURO Type -



FEATURES:

- ◆ Dual miter cutting
- ◆ Coolant pump
- ◆ Hydraulic cylinder
- ◆ Blade tension gauge
- ◆ Magnetic switch 24V & CE
- ◆ Round table

MODEL	BMT 350R
Capacity (90°)	● 270 mm, ■ 260 x 260 mm, ■ 260 x 320 mm
Capacity (45°)	● 230 mm, ■ 220 x 220 mm, ■ 220 mm
Capacity (60°)	● 140 mm, ■ 140 x 140 mm, ■ 140 mm
Capacity (L45°)	● 200 mm, ■ 175 x 175 mm, ■ 220 x 150 mm
Blade Size	27 x 0.9 x 2925 mm
Blade Speed	36 mpm, 72 mpm Inverter, 20~70 mpm (opt.)
Blade Motor	3 HP / 3 HP (opt.)
Packing Size	1930 x 970 x 1120 mm
N.W. / G.W.	420 kgs / 470 kgs
Container Loads	12 sets / 20'

*Specifications are subject to change without prior notice.

BMT 350RN

- Manual Bandsaw / EURO Type -



Easily accessible control panel

*Machine shown with optional accessories

FEATURES:

- ◆ Dual miter cutting
- ◆ Coolant pump
- ◆ Hydraulic cylinder
- ◆ Blade tension gauge
- ◆ Magnetic switch 24V & CE
- ◆ Round table

MODEL	BMT 350RN
Capacity (90°)	● 270 mm, ■ 260 x 260 mm, ■ 260 x 320 mm
Capacity (45°)	● 230 mm, ■ 220 x 220 mm, ■ 220 mm
Capacity (60°)	● 140 mm, ■ 140 x 140 mm, ■ 140 mm
Capacity (L45°)	● 200 mm, ■ 175 x 175 mm, ■ 220 x 150 mm
Blade Size	27 x 0.9 x 2925 mm
Blade Speed	36 mpm, 72 mpm Inverter, 20~70 mpm (opt.)
Blade Motor	3 HP / 3 HP (opt.)
Packing Size	1930 x 970 x 1120 mm
N.W. / G.W.	445 kgs / 495 kgs
Container Loads	12 sets / 20'

*Specifications are subject to change without prior notice.

BMT 350A

- Semi-Automatic Bandsaw / EURO Type -



*Machine shown with optional accessories

FEATURES:

- ◆ Dual miter cutting
- ◆ Coolant pump
- ◆ Hydraulic cylinder
- ◆ Blade tension gauge
- ◆ Magnetic switch 24V & CE

MODEL	BMT 350A
Capacity (90°)	● 270 mm, ■ 270 x 270 mm, ■ 230 x 330 mm
Capacity (45°)	● 230 mm, ■ 220 x 220 mm, ■ 210 x 220 mm
Capacity (60°)	● 140 mm, ■ 140 x 140 mm, ■ 140 x 140 mm
Capacity (L45°)	● 220 mm, ■ 180 x 180 mm, ■ 140 x 200 mm
Blade Size	27 x 0.9 x 2925 mm
Blade Speed	36 mpm, 72 mpm Inverter, 20~70 mpm (opt.)
Blade Motor	3 HP / 3 HP (opt.)
Packing Size	1930 x 970 x 1120 mm
N.W. / G.W.	552 kgs / 622 kgs
Container Loads	12 sets / 20'

*Specifications are subject to change without prior notice.

BMT 350V

- Fully Automatic Bandsaw / EURO Type -



FEATURES:

- ◆ Dual miter cutting
- ◆ Coolant pump
- ◆ Hydraulic cylinder
- ◆ Blade tension gauge
- ◆ Magnetic switch 24V & CE
- ◆ Inverter variable speed

MODEL	BMT 350V
Capacity (90°)	● 260 mm, ■ 250 x 250 mm, ■ 230 x 300 mm
Capacity (45°)	● 230 mm, ■ 220 x 220 mm, ■ 210 x 220 mm
Capacity (60°)	● 140 mm, ■ 140 x 140 mm, ■ 140 x 140 mm
Blade Size	27 x 0.9 x 2925 mm
Blade Speed	20~100 mpm
Blade Motor	3 HP
Packing Size	1920 x 1900 x 1820 mm
N.W. / G.W.	1030 kgs / 1150 kgs
Container Loads	3 sets / 20'

*Specifications are subject to change without prior notice.

10.5" (260~270 mm)

BMT 350SD

- Manual Bandsaw / EURO Type -



*Machine shown with optional accessories

FEATURES:

- ◆ Dual angle vise
- ◆ Manual or controlled descent cutting
- ◆ Auto cutting device

MODEL	BMT 350SD
Capacity (90°)	● 270 mm, ■ 260 x 260 mm, ■ 220 x 350 mm
Capacity (45°)	● 240 mm, ■ 220 x 220 mm, ■ 160 x 240 mm
Capacity (60°)	● 160 mm, ■ 150 x 150 mm
Capacity (L45°)	● 210 mm, ■ 180 x 180 mm
Blade Size	27 x 0.9 x 3160 mm
Blade Speed	4P: 72 mpm, 8P: 36 mpm @ 50Hz
Blade Motor	2 HP
Packing Size	1841 x 749 x 1092 mm
N.W. / G.W.	360 kgs / 410 kgs
Container Loads	18 sets / 20', 36 sets / 40'

*Specifications are subject to change without prior notice.

BMT 350SADI

- Semi-Automatic Bandsaw / EURO Type -



FEATURES:

- ◆ Dual miter cutting
- ◆ Down feed control valve
- ◆ Inverter variable speed
- ◆ Blade tension gauge
- ◆ Hydraulic vise

MODEL	BMT 350SADI
Capacity (90°)	● 270 mm, ■ 260 x 260 mm, ■ 220 x 350 mm
Capacity (45°)	● 240 mm, ■ 220 x 220 mm, ■ 160 x 240 mm
Capacity (60°)	● 160 mm, ■ 150 x 150 mm
Capacity (L45°)	● 210 mm, ■ 180 x 180 mm
Blade Size	27 x 0.9 x 3160 mm
Blade Speed	Vari. speed (inverter), 20~85 mpm
Blade Motor	2 HP AC motor
Packing Size	1880 x 749 x 1715 mm
N.W. / G.W.	460 kgs / 530 kgs
Container Loads	9 sets / 20', 18 sets / 40'

*Specifications are subject to change without prior notice.

BMT 350ARI

- Semi-Automatic Bandsaw / EURO Type -



Easily accessible control panel

*Machine shown with optional accessories

FEATURES:

- ◆ Dual miter cutting
- ◆ Down feed control valve
- ◆ Inverter variable speed
- ◆ Blade tension gauge
- ◆ Hydraulic vise

MODEL	BMT 350ARI
Capacity (90°)	● 270 mm, ■ 260 x 260 mm, ■ 220 x 350 mm
Capacity (45°)	● 240 mm, ■ 220 x 220 mm, ■ 160 x 240 mm
Capacity (60°)	● 160 mm, ■ 150 x 150 mm
Capacity (L45°)	● 210 mm, ■ 180 x 180 mm
Blade Size	27 x 0.9 x 3160 mm
Blade Speed	Vari. speed (inverter), 20~85 mpm
Blade Motor	2 HP
Packing Size	1830 x 780 x 1662 mm
N.W. / G.W.	415 kgs / 465 kgs

*Specifications are subject to change without prior notice.

BMT 350DSAG / BMT 350DSAGV

- Semi-Automatic Bandsaw -



FEATURES:

- ◆ Sliding vise base
- ◆ Blade tension indicator gauge
- ◆ Swiveling control box (for BMT 350DSAGV)
- ◆ Motor inverter controlled blade speed to provide a high efficiency and variable speed conversion (for BMT 350DSAGV)

MODEL	BMT 350DSAG / BMT 350DSAGV
Capacity (90°)	● 270 mm, ■ 270 x 270 mm, ■ 260 x 350 mm
Capacity (45°)	● 230 mm, ■ 180 x 180 mm, ■ 95 x 240 mm
Capacity (L45°)	● 210 mm, ■ 170 x 170 mm, ■ 70 x 245 mm
Capacity (60°)	● 135 mm, ■ 90 x 90 mm, ■ 90 x 135 mm
Blade Size	27 x 0.9 x 3160 mm
Blade Speed	4P: 72 mpm, 8P: 36 mpm for BMT 350DSAG Vari. speed (Inverter), 20~85 mpm for BMT 350DSAGV
Blade Motor	2 HP
Hydraulic Motor	1/2 HP
Coolant Motor	0.06 HP
Packing Size	2045 x 815 x 1690 mm
N.W. / G.W.	450 kgs / 506 kgs

*Specifications are subject to change without prior notice.

10.5" (260~270 mm)

BMT 1018M / BMT 1018MV

- Manual Bandsaw / US Type -



*Machine shown with optional accessories

FEATURES:

- ◆ Swivel vise
- ◆ Coolant system
- ◆ Optional automatic saw blade breakage power off system
- ◆ Optional frequency inverter
- ◆ Optional roller table
- ◆ Optional blade tension gauge

MODEL	BMT 1018M / BMT 1018MV
Capacity (90°)	● 260 mm, ■ 260 x 260 mm, ■ 125 x 460 mm
Capacity (45°)	● 230 mm, ■ 220 x 220 mm, ■ 220 x 230 mm
Blade Size	27 x 0.9 x 3365 mm
Blade Speed	4 steps, 15~84 mpm Vari. speed, 16~78 mpm
Blade Motor	2 HP
Packing Size	1880 x 750 x 1120 mm
N.W. / G.W.	320 kgs / 370 kgs

*Specifications are subject to change without prior notice.

BMT 1018SM / BMT 1018SMV

- Manual Bandsaw / US Type -



FEATURES:

- ◆ Dual miter cutting
- ◆ Coolant system
- ◆ Optional automatic saw blade breakage power off system
- ◆ Optional frequency inverter
- ◆ Optional roller table
- ◆ Optional blade tension gauge

MODEL	BMT 1018SM / BMT 1018SMV
Capacity (90°)	● 260 mm, ■ 260 x 260 mm, ■ 260 x 430 mm
Capacity (45°)	● 260 mm, ■ 260 x 260 mm, ■ 260 x 300 mm
Capacity (L60°)	● 155 mm, ■ 140 x 140 mm, ■ 155 x 125 mm
Blade Size	27 x 0.9 x 3660 mm
Blade Speed	4 steps, 15~84 mpm Vari. speed, 16~78 mpm
Blade Motor	2 HP
Packing Size	2150 x 1015 x 1130 mm
N.W. / G.W.	470 kgs / 520 kgs

*Specifications are subject to change without prior notice.

BMT 1018SA / BMT 1018SAV

- Semi-Automatic Bandsaw / US Type -



*Machine shown with optional accessories

FEATURES:

- ◆ Swivel vise
- ◆ Coolant system
- ◆ Optional automatic saw blade breakage power off system
- ◆ Optional frequency inverter
- ◆ Optional roller table
- ◆ Optional blade tension gauge

MODEL	BMT 1018SA / BMT 1018SAV
Capacity (90°)	● 260 mm, ■ 260 x 260 mm, ■ 125 x 460 mm
Capacity (45°)	● 230 mm, ■ 220 x 220 mm, ■ 220 x 230 mm
Blade Size	27 x 0.9 x 3365 mm
Blade Speed	4 steps, 15~84 mpm Vari. speed, 16~78 mpm
Blade Motor	2 HP
Packing Size	1880 x 750 x 1120 mm
N.W. / G.W.	340 kgs / 390 kgs

*Specifications are subject to change without prior notice.

BMT 1018SSM / BMT 1018SSMV

- Semi-Automatic Bandsaw / US Type -

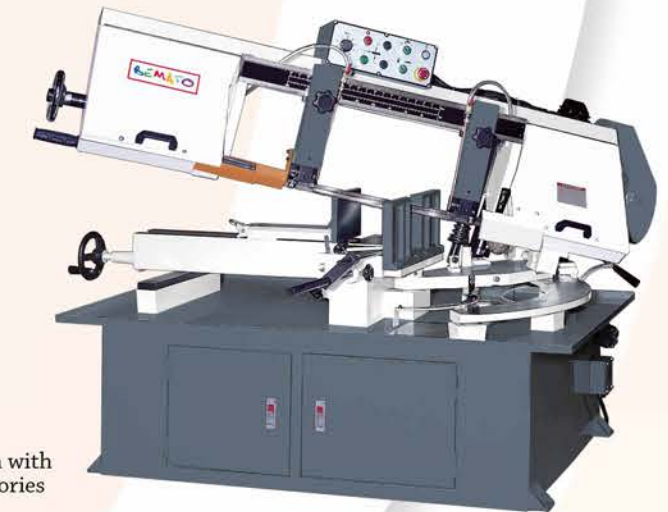

FEATURES:

- ◆ Dual miter cutting
- ◆ Coolant system
- ◆ Optional automatic saw blade breakage power off system
- ◆ Optional frequency inverter
- ◆ Optional roller table
- ◆ Optional blade tension gauge

MODEL	BMT 1018SSM / BMT 1018SSMV
Capacity (90°)	● 260 mm, ■ 260 x 260 mm, ■ 260 x 430 mm
Capacity (45°)	● 260 mm, ■ 260 x 260 mm, ■ 260 x 300 mm
Capacity (L60°)	● 155 mm, ■ 140 x 140 mm, ■ 125 x 155 mm
Blade Size	27 x 0.9 x 3660 mm
Blade Speed	4 steps, 15~84 mpm Vari. speed, 16~78 mpm
Blade Motor	2 HP
Packing Size	2150 x 1015 x 1130 mm
N.W. / G.W.	500 kgs / 550 kgs

*Specifications are subject to change without prior notice.

10.5" (260~270 mm)

BMT 250MHV

- Semi-Automatic Bandsaw / US Type -



*Machine shown with optional accessories

FEATURES:

- ◆ Swivel vise
- ◆ Coolant system
- ◆ Optional automatic saw blade breakage power off system
- ◆ Optional frequency inverter
- ◆ Optional roller table
- ◆ Optional blade tension gauge

MODEL	BMT 250MHV
Capacity (90°)	● 260 mm, ■ 230 x 230 mm, ■ 190 x 360 mm
Capacity (45°)	● 200 mm, ■ 170 x 170 mm, ■ 140 x 215 mm
Blade Size	27 x 0.9 x 3820 mm
Blade Speed	Vari. speed, 18~90 mpm
Blade Motor	2 HP
Packing Size	2090 x 955 x 1320 mm
N.W. / G.W.	600 kgs / 700 kgs

*Specifications are subject to change without prior notice.

BMT 250GHV

- Fully Automatic Bandsaw / US Type -



FEATURES:

- ◆ Swivel vise
- ◆ Coolant system
- ◆ Automatic saw blade breakage power off system
- ◆ 1.5M roller table
- ◆ Optional frequency inverter
- ◆ Optional blade tension gauge

MODEL	BMT 250GHV
Capacity (90°)	● 260 mm, ■ 230 x 230 mm, ■ 190 x 360 mm
Blade Size	27 x 0.9 x 3820 mm
Blade Speed	Vari. speed, 18~90 mpm
Blade Motor	2 HP
Packing Size	2090 x 955 x 1320 mm
N.W. / G.W.	700 kgs / 800 kgs

*Specifications are subject to change without prior notice.

BMT 250FHV

- Fully Automatic Bandsaw / US Type -



*Machine shown with optional accessories

FEATURES:

- ◆ Swivel vise
- ◆ Coolant system
- ◆ Automatic saw blade breakage power off system
- ◆ 1.5M roller table
- ◆ Optional frequency inverter
- ◆ Optional blade tension gauge

MODEL	BMT 250FHV
Capacity (90°)	● 260 mm, ■ 230 x 230 mm, ■ 190 x 360 mm
Blade Size	27 x 0.9 x 3820 mm
Blade Speed	Vari. speed, 18~90 mpm
Blade Motor	2 HP
Packing Size	2090 x 955 x 1320 mm
N.W. / G.W.	700 kgs / 800 kgs

*Specifications are subject to change without prior notice.

12" (300~305 mm)

BMT 300RRF

- Semi-Automatic Bandsaw / US Type -



*Machine shown with optional accessories

FEATURES:

- ◆ Swivel base
- ◆ Hydraulic vise
- ◆ Optional variable speed
- ◆ Optional hydraulic blade tension gauge

MODEL	BMT 300RRF
Capacity (90°)	● 300 mm, ■ 300 x 300 mm, ■ 300 x 432 mm
Capacity (45°)	● 300 mm, ■ 255 x 255 mm, ■ 203 x 300 mm
Blade Size	34 x 1.1 x 3950 mm
Blade Speed	4 steps 26/48/69/100 mpm @ 60 Hz 22/40/58/84 mpm @ 50 Hz
Blade Motor	3 HP
Packing Size	1940 x 1140 x 1530 mm
N.W. / G.W.	740 kgs / 800 kgs
Container Loads	6 sets / 20', 12 sets / 40'

*Specifications are subject to change without prior notice.

BMT 300SHV

- Semi-Automatic Bandsaw / US Type -



FEATURES:

- ◆ Swivel vise
- ◆ Coolant system
- ◆ Optional automatic saw blade breakage power off system
- ◆ Optional frequency inverter
- ◆ Optional roller table
- ◆ Optional blade tension gauge

MODEL	BMT 300SHV
Capacity (90°)	● 300 mm, ■ 230 x 230 mm, ■ 230 x 330 mm
Capacity (45°)	● 240 mm, ■ 190 x 190 mm, ■ 190 x 240 mm
Blade Size	27 x 0.9 x 3820 mm
Blade Speed	Vari. speed, 17~84 mpm
Blade Motor	3 HP
Packing Size	2180 x 790 x 1560 mm
N.W. / G.W.	850 kgs / 950 kgs

*Specifications are subject to change without prior notice.

BMT 300HSA

- Semi-Automatic Bandsaw / Double Column -

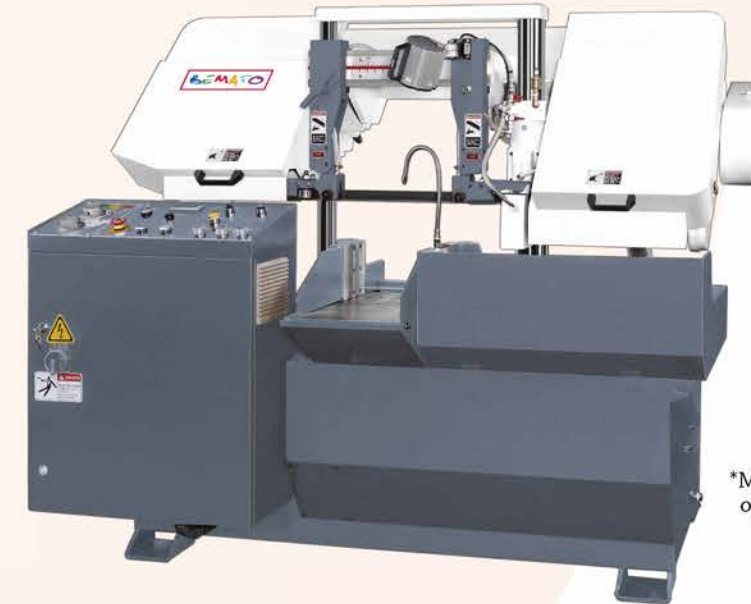

*Machine shown with optional accessories

FEATURES:

- ◆ Inverter variable speed + LED display of blade speed
- ◆ Hydraulic blade tension device
- ◆ Hydraulic clamping vise
- ◆ Check device of saw blade breaking
- ◆ Hydraulic lift up roller
- ◆ Control rod of height

MODEL	BMT 300HSA
Capacity (90°)	● 300 mm, ■ 300 x 300 mm (Min. ● 10 mm, ■ 10 x 10 mm)
Blade Size	41 x 1.3 x 3920 mm
Blade Speed	Vari. speed (Inverter), 20~100 mpm
Blade Motor	5 HP
Hydraulic Motor, Tank	1 HP, 60 L
Coolant Motor, Tank	1/8 HP, 70 L
Feeding Stroke	400 mm x 9
Table Height	780 mm
Machine Size	2000 x 1110 x 1180 mm
N.W.	1300 kgs

*Specifications are subject to change without prior notice.

12" (300~305 mm)

BMT 300FHV

- Fully Automatic Bandsaw / US Type -



*Machine shown with optional accessories

FEATURES:

- ◆ Counting device
- ◆ Coolant system
- ◆ Automatic saw blade breakage power off system
- ◆ 1.5 M roller table
- ◆ Optional frequency inverter
- ◆ Optional blade tension gauge

MODEL	BMT 300FHV
Capacity (90°)	● 300 mm, ■ 260 x 260 mm, ■ 200 x 330 mm
Blade Size	27 x 0.9 x 3820 mm
Blade Speed	Vari. speed, 20~96 mpm
Blade Motor	3 HP
Packing Size	2090 x 955 x 1320 mm
N.W. / G.W.	900 kgs / 1000 kgs

*Specifications are subject to change without prior notice.

BMT 300SFA

- Fully Automatic Bandsaw / US Type -



*Machine shown with optional accessories

FEATURES:

- ◆ Swivel frame
- ◆ Coolant system
- ◆ Automatic saw blade breakage power off system
- ◆ 1.5 M roller table
- ◆ Frequency inverter
- ◆ Saw blade speed digital indicator
- ◆ Hydraulic chip conveyor
- ◆ Hydraulic dual vise

MODEL	BMT 300SFA
Capacity (90°)	● 300 mm, ■ 300 x 300 mm, ■ 200 x 400 mm
Capacity (45°)	● 260 mm, ■ 260 x 260 mm
Blade Size	27 x 0.9 x 3820 mm
Blade Speed	Vari. speed (inverter), 15~90 mpm
Blade Motor	3 HP
Hydraulic Motor, Tank	1 HP, 45 L
Coolant Motor, Tank	50 L
Feeding Stroke	500 mm
Packing Size	2340 x 2240 x 1710 mm
N.W. / G.W.	1250 kgs / 1470 kgs

*Specifications are subject to change without prior notice.

BMT 300H

- Fully Automatic Bandsaw / Double Column -



*Machine shown with optional accessories

FEATURES:

- ◆ Inverter variable speed
- ◆ Hydraulic blade tension device
- ◆ Hydraulic clamping system
- ◆ Carbide blade guide system
- ◆ Nesting fixture for bundle cutting
- ◆ Preset cut-counter with shut-off
- ◆ Power driven wire brush
- ◆ 2M roller table
- ◆ Split front vise
- ◆ Floating shuttle vise
- ◆ PLC control
- ◆ Multiple index
- ◆ Automatic work height control
- ◆ Automatic chip conveyor
- ◆ LED display of blade speed
- ◆ Check devise of saw blade breakage
- ◆ Shuttle type automatic feed

MODEL	BMT 300H
Capacity (90°)	● 300 mm, ■ 300 x 300 mm
Blade Size	34 x 1.1 x 3920 mm
Blade Speed	Vari. speed (inverter), 20~100 mpm
Blade Motor	5 HP
Hydraulic Motor, Tank	1 HP, 60 L
Coolant Motor, Tank	1/8 HP, 70 L
Bundle Cutting (H x W)	145~230 x 30~130 mm
Feeding Stroke	400 mm x 9
Table Height	780 mm
Machine Size	2100 x 2050 x 1700 mm
N.W.	1650 kgs

*Specifications are subject to change without prior notice.

12" (300~305 mm)

BMT 310WAC

- Fully Automatic Bandsaw / Double Column -
- For Aluminum Billet High-Speed Cutting Line -



*Machine shown with optional accessories

FEATURES:

- ◆ Material storage, auto-detecting and loading system
- ◆ Accurate feeding length by servomotor
- ◆ Touch screen can save in different cutting jobs
- ◆ Motor inverter controls variable blade speed
- ◆ Servo motor controls multiple cutting down speed
- ◆ Automatic chip conveyor
- ◆ Auto-current sensing to reduce down speed or stops cutting to prevent saw damage
- ◆ Cut material auto-loading, can add power roller stand to move material out
- ◆ Residual piece auto-clamping and moving out robot
- ◆ Coolant supply tank, coolant low level alarm



MODEL	BMT 310WAC
Capacity	● 170~305 mm
Blade Size	54 x 1.6 x 5400 mm
Blade Speed	Vari. speed (inverter), 300~900 mpm
Blade Motor	15 HP
Down Feed Servo Motor	2 HP
Shuttle Servo Motor	1 HP
Reversal Motor	2 HP
Chip Conveyor Motor	1/4 HP
Residual Motor	1 HP
Hydraulic Motor, Tank	2 HP, 50 L
Coolant Motor, Tank	1 HP, 140 L
Spare Coolant Tank	180 L
Machine Size	8060 x 4560 x 3500 mm
N.W.	8500 kgs
Power Roller Motor	2 HP
Storage Stand Hydraulic Motor, Tank	1 HP, 30 L
Storage Stand Size	4710 x 2400 x 1165 mm
Storage Stand Weight	3150 kgs

*Specifications are subject to change without prior notice.

13" (310~331 mm)

BMT 350YSA

- Semi-Automatic Bandsaw / EURO Type -

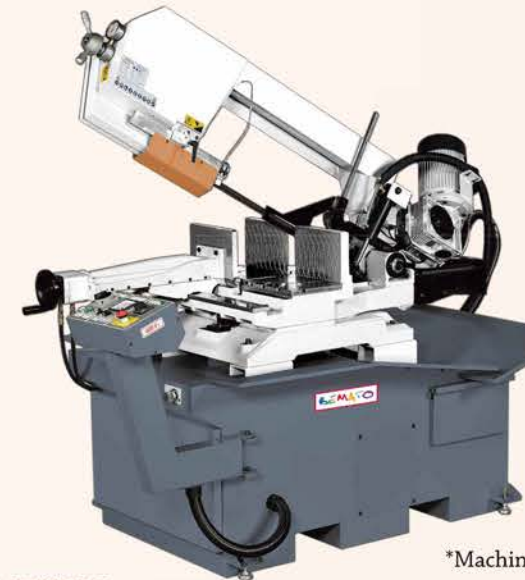

*Machine shown with optional accessories

FEATURES:

- ◆ Dual miter cutting
- ◆ Feed down speed control
- ◆ Hydraulic vise with adjustable guides
- ◆ Easy stops at 0°, 30°, 45°, 60° left and 30°, 45° right
- ◆ Blade tension gauge
- ◆ Position sensor allows the saw frame to lower quickly toward material and detect automatically the start-cut point
- ◆ Floor stand with removable chip tank

MODEL	BMT 350YSA
Capacity (90°)	● 310 mm, ■ 300 x 300 mm, ■ 350 x 300 mm
Capacity (45°)	● 310 mm, ■ 300 x 300 mm, ■ 330 x 300 mm
Capacity (60°)	● 200 mm, ■ 200 x 200 mm, ■ 200 x 200 mm
Capacity (L45°)	● 270 mm, ■ 230 x 230 mm, ■ 255 x 200 mm
Blade Size	27 x 0.9 x 3800 mm
Blade Speed	40/80 mpm
Motor	AC 2 HP
Cooling	Yes
Machine Size	2180 x 1185 x 2140 mm
Packing Size	2020 x 1160 x 1715 mm
N.W. / G.W.	780 kgs / 840 kgs
Container Loads	5 sets / 20'

*Specifications are subject to change without prior notice.

BMT 330A / BMT 330AV

- Manual Bandsaw / US Type -



FEATURES:

- ◆ 4 speeds for BMT 330A
- ◆ Variable speed for BMT 330AV
- ◆ Coolant system

MODEL	BMT 330A / BMT 330AV
Capacity (90°)	● 330 mm, ■ 330 x 480 mm, ■ 225 x 530 mm
Capacity (45°)	● 255 mm, ■ 280 x 255 mm
Blade Size	34 x 1.1 x 4100 mm
Blade Speed	4 steps, 28/40/56/78 mpm / Vari. speed, 24~79 mpm
Blade Motor	3 HP
Table Height	680 mm
Packing Size	2223 x 775 x 1512 mm
N.W. / G.W.	600 kgs / 690 kgs
Container Loads	7 sets / 20', 14 sets / 40'

*Specifications are subject to change without prior notice.

13" (310~331 mm)

BMT 330SSA / BMT 330HSSA

- Semi-Automatic Bandsaw / US Type -



*Machine shown with optional accessories

FEATURES:

- ◆ Swivel arm
- ◆ Coolant system
- ◆ Hydraulic vise for BMT 330HSSA
- ◆ Safety device for saw blade breaker for BMT 330HSSA

MODEL	BMT 330SSA / BMT 330HSSA
Capacity (90°)	● 330 mm, ■ 330 x 480 mm, ■ 225 x 530 mm
Capacity (45°)	● 275 mm, ■ 300 x 275 mm
Blade Size	34 x 1.1 x 4100 mm
Blade Speed	Vari. speed, 20~80 mpm
Blade Motor	3 HP
Hydraulic Motor	1/3 HP
Table Height	730 mm
Packing Size	2286 x 935 x 1499 mm
N.W. / G.W.	750 kgs / 860 kgs
Container Loads	6 sets / 20', 13 sets / 40'

*Specifications are subject to change without prior notice.

BMT 1318S / BMT 1318SSA / BMT 1318SSAV

- Manual Bandsaw / US Type for BMT 1318S -
- Semi-Automatic Bandsaw / US Type for other models -



FEATURES:

- ◆ Miter cutting
- ◆ 4 speeds for BMT 1318S & BMT 1318SSA
- ◆ Variable speed & blade speed indicator for BMT 1318SSAV
- ◆ Pivot link can be disassembled for easy maintenance.
- ◆ Hydraulic vise clamps material with precision and stability.
- ◆ Control panel combined with electrical control system, saw bow stroke adjusting device and drop rate control device.

MODEL	BMT 1318S / BMT 1318SSA / BMT 1318SSAV
Capacity (90°)	● 330 mm, ■ 330 x 450 mm
Capacity (45°)	● 280 mm, ■ 330 x 280 mm
Capacity (60°)	● 160 mm, ■ 250 x 160 mm
Blade Size	27 x 0.9 x 4130 mm
Blade Speed	4 steps, 28/41/60/78 mpm Vari. speed, 27~78 mpm for BMT 1318SSAV
Blade Motor	3 HP
Hydraulic Motor	1/2 HP, 10 L for BMT 1318SSA & BMT 1318SSAV
Coolant Motor	1/8 HP, 30 L
Packing Size	2110 x 940 x 1595 mm & 1665 x 850 x 600 mm for BMT 1318S 2240 x 940 x 1595 mm & 1665 x 850 x 600 mm for others 850 kgs / 970 kgs for BMT 1318S 890 kgs / 1030 kgs for BMT 1318SSA & BMT 1318SSAV
N.W. / G.W.	

*Specifications are subject to change without prior notice.

BMT 20WS / BMT 20WSSA / BMT 20WSSAV

- Manual Bandsaw / US Type for BMT 20WS -
- Semi-Automatic Bandsaw / US Type for other models -



*Machine shown with optional accessories

FEATURES:

- ◆ Dual miter cutting
- ◆ Blade tension gauge
- ◆ Manual locking vise for BMT 20WS & BMT 20WSSA
- ◆ Hydraulic vise for BMT 20WSSAV
- ◆ Chip collecting drawer
- ◆ Inverter variable speed
- ◆ Blade speed indicator

MODEL	BMT 20WS / BMT 20WSSA / BMT 20WSSAV
Capacity (90°)	● 330 mm, ■ 330 x 460 mm
Capacity (45°)	● 305 mm, ■ 330 x 270 mm
Capacity (60°)	● 215 mm, ■ 315 x 195 mm
Capacity (L45°)	● 305 mm, ■ 330 x 270 mm
Blade Size	34 x 1.1 x 4130 mm
Blade Speed	Vari. speed (inverter), 21~93 mpm
Blade Motor	3 HP
Coolant Motor	1/6 HP, 55 L
Packing Size	2270 x 900 x 1670 mm
N.W. / G.W.	814 kgs / 920 kgs for BMT 20WS 834 kgs / 940 kgs for BMT 20WSSA 990 kgs / 1090 kgs for BMT 20WSSAV

*Specifications are subject to change without prior notice.

BMT 1324A

- Semi-Automatic Bandsaw / US Type -



FEATURES:

- ◆ Swivel vise
- ◆ Automatic saw blade breakage power off system
- ◆ Inverter variable speed
- ◆ Hydraulic vise
- ◆ Coolant system
- ◆ Optional blade tension gauge
- ◆ Optional roller table

MODEL	BMT 1324A
Capacity (90°)	● 330 mm, ■ 330 x 330 mm, ■ 330 x 630 mm
Capacity (45°)	● 330 mm, ■ 330 x 330 mm, ■ 200 x 400 mm
Blade Size	34 x 1.1 x 4150 mm
Blade Speed	Vari. speed (inverter), 15~90 mpm
Blade Motor	3 HP
Packing Size	2220 x 910 x 1365 mm
N.W. / G.W.	640 kgs / 740 kgs

*Specifications are subject to change without prior notice.

13" (310~331 mm)

BMT 1324SA

- Semi-Automatic Bandsaw / US Type -



*Machine shown with optional accessories

FEATURES:

- ◆ Dual miter cutting
- ◆ Automatic saw blade breakage power off system
- ◆ Inverter variable speed
- ◆ Hydraulic vise
- ◆ Coolant system
- ◆ 750mm roller stand
- ◆ Optional blade tension gauge

MODEL	BMT 1324SA
Capacity (90°)	● 330 mm, ■ 330 x 330 mm, ■ 300 x 600 mm
Capacity (45°)	● 330 mm, ■ 330 x 330 mm, ■ 200 x 400 mm
Capacity (L60°)	● 280 mm, ■ 280 x 280 mm, ■ 180 x 300 mm
Blade Size	34 x 1.1 x 4365 mm
Blade Speed	Vari. speed (inverter), 15~90 mpm
Blade Motor	3 HP
Packing Size	2280 x 1500 x 1365 mm
N.W. / G.W.	830 kgs / 950 kgs

*Specifications are subject to change without prior notice.

BMT 1318D / BMT 1318DS / BMT 1318DSV

- Manual Bandsaw / US Type for BMT 1318D -
- Semi-Automatic Bandsaw / US Type for others -



FEATURES:

- ◆ Dual miter cutting
- ◆ Hydraulic controlled down feed
- ◆ Moveable coolant tray
- ◆ Variable speed
- ◆ Vise with hand wheel for BMT 1318D & BMT 1318DS
- ◆ Vise with hydraulic cylinder for BMT 1318DSV
- ◆ Easily moving vise with sliding bearing

MODEL	BMT 1318D / BMT 1318DSV / BMT 1318DSAV
Capacity (90°)	● 330 mm, ■ 330 x 450 mm
Capacity (45°)	● 280 mm, ■ 330 x 280 mm
Capacity (L60°)	● 220 mm, ■ 220 x 175 mm
Blade Size	27 x 0.9 x 3810 mm
Blade Speed	Vari. speed, 25~85 mpm
Blade Motor	2 HP
Coolant Motor, Tank	1/8 HP, 28 L
Table Height	880 mm
Packing Size	2080 x 1010 x 1540 mm
N.W. / G.W.	532 kgs / 585 kgs for BMT 1318D 594 kgs / 650 kgs for others

*Specifications are subject to change without prior notice.

BMT 331DSA / BMT 331DSAE

- Semi-Automatic Bandsaw / US Type -



*Machine shown with optional accessories

FEATURES:

- ◆ Dual miter cutting
- ◆ Set bow height from control panel for BMT 331DSA
- ◆ Push button style control panel for BMT 331DSAE
- ◆ Vise pressure regulator for BMT 331DSA
- ◆ Blade tension gauge
- ◆ Vise movement by manual
- ◆ Digital blade speed indicator

MODEL	BMT 331DSA / BMT 331DSAE
Capacity (90°)	● 331 mm, ■ 320 x 485 mm, ■ 260 x 510 mm
Capacity (45°)	● 315 mm, ■ 315 x 315 mm
Capacity (60°)	● 215 mm, ■ 195 x 315 mm
Capacity (L45°)	● 315 mm, ■ 315 x 315 mm
Capacity (L60°)	● 215 mm, ■ 195 x 315 mm
Blade Size	34 x 1.1 x 4180 mm
Blade Speed	Vari. speed, 32~96 mpm @ 60Hz
Blade Motor	3 HP
Hydraulic Tank	12 L
Coolant Tank	52 L
Packing Size	2310 x 1060 x 1500 mm
N.W. / G.W.	850 kgs / 965 kgs

*Specifications are subject to change without prior notice.

BMT 1318FA

- Fully Automatic Bandsaw / US Type -



FEATURES:

- ◆ Swiveling saw head manually
- ◆ Touch screen and length encoder
- ◆ Vise pressure regulator
- ◆ Vertical vises for bundle cutting
- ◆ Auto chip conveyor
- ◆ Blade tension gauge
- ◆ Bow height setting manually

MODEL	BMT 1318FA
Capacity (90°)	● 330 mm, ■ 330 x 410 mm
Capacity (45°)	● 280 mm, ■ 330 x 260 mm
Blade Size	27 x 0.9 x 4130 mm
Blade Speed	Vari. speed (inverter), 30~85 mpm
Blade Motor	5 HP AC motor
Hydraulic Motor, Tank	1/2 HP
Coolant Motor, Tank	1/8 HP
Bundle Cutting (H x W)	300 x 410 mm
Cut Off Length	over 8 mm
Feeding Stroke	700 mm
Table Height	820 mm
Packing Size	2280 x 2190 x 1730 mm
N.W. / G.W.	1400 kgs / 1668 kgs

*Specifications are subject to change without prior notice.

13" (310~331 mm)

BMT 330SFA

- Fully Automatic Bandsaw / US Type -



*Machine shown with optional accessories

FEATURES:

- ◆ Swivel arm
- ◆ Automatic saw blade breakage power off system
- ◆ Inverter variable speed
- ◆ Counting device
- ◆ Digital blade speed indicator
- ◆ Hydraulic dual vise
- ◆ Hydraulic chip conveyor
- ◆ Coolant system

MODEL	BMT 330SFA
Capacity (90°)	● 330 mm, ■ 260 x 260 mm, ■ 260 x 450 mm
Capacity (45°)	● 330 mm, ■ 260 x 260 mm, ■ 260 x 330 mm
Blade Size	34 x 1.1 x 4150 mm
Blade Speed	Vari. speed (inverter), 15~90 mpm
Blade Motor	3 HP
Hydraulic Motor, Tank	1 HP, 44 L
Coolant Motor, Tank	45 L
Feeding Stroke	500 mm
Table Height	690 mm
Packing Size	2600 x 2280 x 1730 mm
N.W. / G.W.	1620 kgs / 1820 kgs

*Specifications are subject to change without prior notice.

BMT 20WSFA

- Fully Automatic Bandsaw / US Type-



FEATURES:

- ◆ Single angle cutting R45° by manual
- ◆ 3D animation HMI control panel
- ◆ Inclination control box design
- ◆ Advanced operation assistance systems, with built-in 12 different error conditions
- ◆ Encoder controlled length setting
- ◆ Floating vice and wash down device
- ◆ Hydraulic blade tension device
- ◆ Hydraulic vertical press vises
- ◆ Inverter variable speed

MODEL	BMT 20WSFA
Capacity (90°)	● 330 mm, ■ 330 x 330 mm, ■ 330 x 405 mm
Capacity (45°)	● 300 mm, ■ 290 x 290 mm, ■ 240 x 330 mm
Blade Size	34 x 1.1 x 4720 mm
Blade Speed	Vari. speed (inverter), 33~105 mpm
Blade Motor	5 HP
Hydraulic Motor, Tank	1 HP, 28 L
Coolant Pump, Tank	1/8 HP, 83 L
Table Height	870 mm
Packing Size	2365 x 2072 x 1635 mm
N.W. / G.W.	1790 kgs / 1869 kgs

*Specifications are subject to change without prior notice.

14" (350~360 mm)

BMT 4033HA

- Fully-Automatic Bandsaw / Double Column -



*Machine shown with optional accessories

FEATURES:

- ◆ Inverter variable speed
- ◆ Hydraulic blade tension device
- ◆ Hydraulic clamping system
- ◆ Carbide blade guide system
- ◆ Nesting fixture for bundle cutting
- ◆ Preset cut-counter with shut-off
- ◆ Power driven wire brush
- ◆ Check device of saw blade breakage
- ◆ Split front vise
- ◆ Floating shuttle vise
- ◆ PLC control
- ◆ 2M roller table
- ◆ Multiple index
- ◆ Automatic work height control
- ◆ Automatic chip conveyor
- ◆ LED display of blade speed
- ◆ Shuttle type automatic feed

MODEL	BMT 4033HA
Capacity (90°)	● 330 mm, ■ 400 x 330 mm
Blade Size	34 x 1.1 x 4570 mm
Blade Speed	Vari. speed (inverter), 20~100 mpm
Blade Motor	5 HP
Hydraulic Motor, Tank	2 HP, 80 L
Coolant Motor, Tank	1/8 HP, 90 L
Bundle Cutting (H x W)	160~280 x 50~150 mm
Feeding Stroke	500 mm x 9
Table Height	800 mm
Machine Size	2230 x 2150 x 1800 mm
N.W.	2350 kgs

*Specifications are subject to change without prior notice.

BMT 500DSAG / BMT 500DSAHG

- Semi-Automatic Bandsaw / EURO Type -

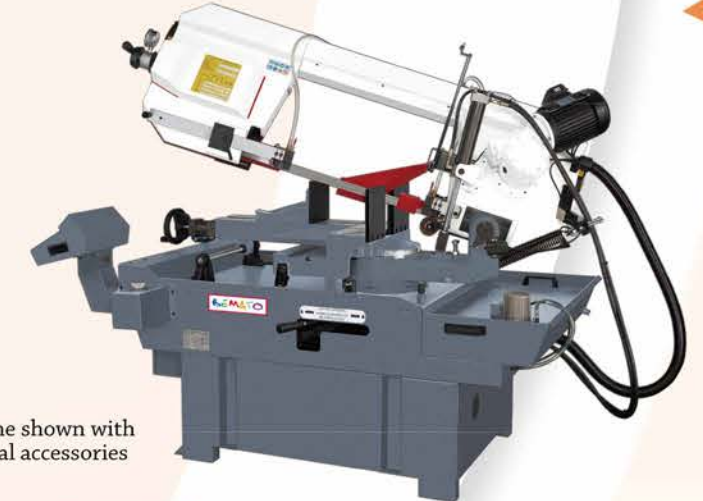

FEATURES:

- ◆ Dual mitter cutting
- ◆ Hydraulic feed control cutting
- ◆ Rack and hydraulic clamping vise for BMT 500SAK
- ◆ Manual clamping vise for BMT 500DSA K1
- ◆ Easily moving vise with sliding bearing
- ◆ Protective panel guard plate
- ◆ Inverter variable speed
- ◆ Blade tension device with indicator
- ◆ Reduced cycle time material feeler

MODEL	BMT 500DSAG / BMT 500DSAHG
Capacity (90°)	● 350 mm, ■ 330 x 330 mm, ■ 200 x 500 mm
Capacity (45°)	● 330 mm, ■ 250 x 250 mm, ■ 145 x 340 mm
Capacity (60°)	● 210 mm, ■ 135 x 135 mm, ■ 125 x 220 mm
Capacity (L45°)	● 290 mm, ■ 230 x 230 mm, ■ 60 x 345 mm
Blade Size	34 x 1.1 x 3880 mm
Blade Speed	Vari. speed (Inverter), 20~85 mpm
Blade Motor	3 HP
Hydraulic Motor	1 HP
Coolant Motor	0.06 HP
Packing Size	2240 x 930 x 1770 mm
N.W. / G.W.	677 kgs / 757 kgs
Container Loads	6 sets / 20', 12 sets / 40'

*Specifications are subject to change without prior notice.

14" (350~360 mm)

BMT 355A

- Manual Bandsaw / EURO Type -



*Machine shown with optional accessories

BMT 355

- Semi-Automatic Bandsaw / EURO Type -



FEATURES:

- ◆ Dual mitter cutting
- ◆ Inverter variable speed
- ◆ Coolant pump
- ◆ Magnetic switch 24V & CE
- ◆ Hydraulic cylinder
- ◆ Blade tension gauge
- ◆ Hydraulic vise clamping

FEATURES:

- ◆ Dual miter cutting
- ◆ Coolant pump
- ◆ Magnetic switch 24V & CE
- ◆ Hydraulic cylinder
- ◆ Blade tension gauge
- ◆ Optional inverter variable speed

MODEL	BMT 355A
Cutting Capacity (90°)	● 355 mm, ■ 280 x 280 mm, ■ 280 x 530 mm
Cutting Capacity (45°)	● 355 mm, ■ 280 x 280 mm, ■ 280 x 360 mm
Cutting Capacity (60°)	● 240 mm, ■ 170 x 170 mm, ■ 170 x 240 mm
Cutting Capacity (L45°)	● 300 mm, ■ 270 x 270 mm, ■ 270 mm
Blade Size	34 x 1.1 x 3770 mm
Blade Speed	35 mpm, 70 mpm
Motor	2.5 HP
Packing Size	2180 x 970 x 1130 mm
N.W. / G.W.	765 kgs / 815 kgs
Container Loads	12 sets / 20'

*Specifications are subject to change without prior notice.

MODEL	BMT 355
Capacity (90°)	● 355 mm, ■ 300 x 300 mm, ■ 300 x 490 mm
Capacity (45°)	● 350 mm, ■ 290 x 290 mm, ■ 290 x 340 mm
Capacity (60°)	● 230 mm, ■ 180 x 180 mm, ■ 180 x 220 mm
Capacity (L45°)	● 290 mm, ■ 250 x 250 mm, ■ 250 mm
Blade Size	34 x 1.1 x 3770 mm
Blade Speed	Vari. speed (inverter), 20~80 mpm
Blade Motor	3 HP
Packing Size	2180 x 970 x 1130 mm
N.W. / G.W.	645 kgs / 715 kgs
Container Loads	12 sets / 20'

*Specifications are subject to change without prior notice.

BMT 350HSAL / BMT 350HSSAL

- Semi-Automatic Bandsaw / US Type -



*Machine shown with optional accessories

FEATURES:

- ◆ Swivel vise for BMT 350HSAL
- ◆ Swivel arm for BMT 350HSSAL
- ◆ Hydraulic vise
- ◆ Inverter variable speed
- ◆ Specialized for cutting large steel molds for BMT 350HSAL
- ◆ Professional bandsaw for H-beam angle cutting for BMT 350HSSAL
- ◆ Control panel
- ◆ Blade tension gauge

MODEL	BMT 350HSAL / BMT 350HSSAL
Capacity (90°)	● 350 mm, ■ 350 x 750 mm, ■ 250 x 800 mm
Capacity (45°)	● 300 mm, ■ 330 x 330 mm for BMT 350HSAL ● 350 mm, ■ 350 x 430 mm for BMT 350HSSAL
Blade Size	41 x 1.3 x 4710 mm
Blade Speed	Vari. speed (inverter), 24~79 mpm
Blade Motor	5 HP
Hydraulic Motor	1/2 HP
Coolant Tank	52 L
Packing Size	2600 x 960 x 1670 mm
N.W. / G.W.	840 kgs / 953 kgs for BMT 350HSAL 860 kgs / 973 kgs for BMT 350HSSAL

*Specifications are subject to change without prior notice.

BMT 360H

- Semi-Automatic Bandsaw / Double Column -



FEATURES:

- ◆ Rack and hydraulic vise
- ◆ Hydraulic blade tension
- ◆ Variable speed
- ◆ Manual blade speed adjusting device
- ◆ Digital blade speed readout
- ◆ Control panel

MODEL	BMT 360H
Capacity (90°)	● 360 mm, ■ 360 x 360 mm, ■ 360 x 560 mm
Blade Size	34 x 1.1 x 4880 mm
Blade Speed	Vari. speed, 20~85 mpm
Blade Motor	5 HP
Hydraulic Motor, Tank	20 L
Coolant Motor, Tank	1 HP, 90 L
Table Height	742 mm
Packing Size	2500 x 680 x 1715 mm
N.W. / G.W.	1030 kgs / 1140 kgs

*Specifications are subject to change without prior notice.

14" (350~360 mm)

BMT 4036HA

- Fully Automatic Bandsaw / Double Column -



*Machine shown with optional accessories

BMT 4036HAF

- Fully Automatic Bandsaw / Double Column -



FEATURES:

- ◆ PLC control & color touchscreen
- ◆ Precise length encoder
- ◆ Hydraulic blade tension device
- ◆ Inverter variable speed
- ◆ 10 cutting presets memory
- ◆ Automatic chip conveyor
- ◆ Multi-language interface
- ◆ Full stroke hydraulic vise
- ◆ Power driven wire brush
- ◆ Broken blade detector sensor
- ◆ Optional nesting fixture for bundle cutting
- ◆ Optional vise pressure regulator

FEATURES:

- ◆ PLC control & color touchscreen
- ◆ Precise length encoder
- ◆ Hydraulic blade tension device
- ◆ Inverter variable speed
- ◆ Automatic feeding
- ◆ Automatic chip conveyor
- ◆ Multi-language interface
- ◆ Hydraulic tungsten carbide guide
- ◆ Power driven wire brush
- ◆ Optional 2M roller stand
- ◆ Optional nesting fixture for bundle cutting
- ◆ Optional vise pressure regulator

MODEL	BMT 4036HA
Capacity (90°)	● 360 mm, ■ 360 x 400 mm
Blade Size	34 x 1.1 x 4570 mm
Blade Speed	Vari. speed (inverter), 30~85 mpm
Blade Motor	5 HP
Hydraulic Motor, Tank	1 HP, 40 L
Coolant Motor, Tank	1/6 HP, 80 L
Bundle Cutting (H x W)	180~280 x 50~160 mm
Cut Off Length	over 10 mm
Feeding Stroke	400 mm
Minimum No Material Detecting	32 mm
Minimum Residual Work Length	100 mm
Table Height	755 mm
Packing Size	2400 x 2120 x 1840 mm
N.W. / G.W.	1680 kgs / 1910 kgs

*Specifications are subject to change without prior notice.

MODEL	BMT 4036HAF
Capacity (90°)	● 360 mm, ■ 360 x 400 mm
Blade Size	34 x 1.1 x 4570 mm
Blade Speed	Vari. speed (inverter), 30~85 mpm
Blade Motor	5 HP
Hydraulic Motor, Tank	1 HP, 40 L
Coolant Motor, Tank	1/6 HP, 80 L
Bundle Cutting (H x W)	180~280 x 50~160 mm
Cut Off Length	over 10 mm
Feeding Stroke	400 mm
Minimum No Material Detecting	32 mm
Minimum Residual Work Length	100 mm
Table Height	755 mm
Packing Size	2400 x 2120 x 1840 mm
N.W. / G.W.	2500 kgs

*Specifications are subject to change without prior notice.

BMT 420YSA / BMT 460YSA

- Semi-Automatic Bandsaw / EURO Type-



*Machine shown with optional accessories

FEATURES:

- ◆ Dual miter cutting
- ◆ Feed down speed control
- ◆ Hydraulic vise with adjustable guides
- ◆ Easy stops at 0°, 30°, 45°, 60° left and 30°, 45° right
- ◆ Blade tension gauge
- ◆ Position sensor allows the saw frame to lower quickly toward material and detect automatically the start-cut point
- ◆ loor stand with removable chip tank

MODEL	BMT 420YSA	BMT 460YSA
Cutting Capacity (90°)	● 350 mm, ■ 330 x 330 mm, ■ 420 x 330 mm	● 350 mm, ■ 330 x 330 mm, ■ 460 x 310 mm
Cutting Capacity (45°)	● 310 mm, ■ 310 x 310 mm, ■ 335 x 200 mm	● 310 mm, ■ 310 x 310 mm, ■ 335 x 200 mm
Cutting Capacity (60°)	● 235 mm, ■ 235 x 235 mm, ■ 235 x 235 mm	● 235 mm, ■ 235 x 235 mm, ■ 235 x 235 mm
Cutting Capacity (L45°)	● 280 mm, ■ 240 x 240 mm, ■ 260 x 220 mm	● 280 mm, ■ 240 x 240 mm, ■ 260 x 220 mm
Blade Size	34 x 0.9 x 3880 mm	
Blade Speed	40/80 mpm	
Motor	AC 2.2 HP	
Cooling	Yes	
Machine Size	2220 x 1185 x 2190 mm	2360 x 1185 x 2190 mm
Packing Size	2020 x 1160 x 1715 mm	2120 x 1160 x 1715 mm
N.W. / G.W.	800 kgs / 860 kgs	820 kgs / 880 kgs
Container Loads	5 sets / 20'	

*Specifications are subject to change without prior notice.

15" (380 mm)

BMT 380MH / BMT 380MHV

- Semi-Automatic Bandsaw / Pivot Type -



*Machine shown with optional accessories

FEATURES:

- ◆ Swivel vise
- ◆ Coolant system
- ◆ Optional automatic saw blade breakage power off system
- ◆ Optional hydraulic vise
- ◆ Optional inverter variable speed
- ◆ Optional blade tension gauge
- ◆ Optional roller table

MODEL	BMT 380MH / BMT 380MHV
Capacity (90°)	● 380 mm, ■ 300 x 300 mm, ■ 220 x 440 mm
Capacity (45°)	● 280 mm, ■ 230 x 230 mm, ■ 180 x 280 mm
Blade Size	27 x 0.9 x 4265 mm
Blade Speed	6 steps, 14~76 mpm Vari. speed, 21~100 mpm
Blade Motor	3 HP
Packing Size	2280 x 955 x 1485 mm
N.W. / G.W.	1000 kgs / 1100 kgs

*Specifications are subject to change without prior notice.

BMT 380SH / BMT 380SHV

- Semi-Automatic Bandsaw / Pivot Type -



FEATURES:

- ◆ Swivel arm
- ◆ Coolant system
- ◆ Optional automatic saw blade breakage power off system
- ◆ Optional hydraulic vise
- ◆ Optional inverter variable speed
- ◆ Optional blade tension gauge
- ◆ Optional roller table

MODEL	BMT 380SH / BMT 380SHV
Capacity (90°)	● 380 mm, ■ 300 x 300 mm, ■ 280 x 520 mm
Capacity (45°)	● 350 mm, ■ 300 x 300 mm, ■ 300 x 380 mm
Blade Size	27 x 0.9 x 4115 mm
Blade Speed	6 steps, 14~64 mpm Vari. speed, 17~84 mpm
Blade Motor	3 HP
Packing Size	2280 x 790 x 1640 mm
N.W. / G.W.	950 kgs / 1050 kgs

*Specifications are subject to change without prior notice.

BMT 380FH / BMT 380FHV

- Fully Automatic Bandsaw / Pivot Type -



*Machine shown with optional accessories

FEATURES:

- ◆ Roller feed type, electro-clamp
- ◆ Coolant system
- ◆ Automatic saw blade breakage power off system
- ◆ 1.5M roller table
- ◆ Out of stock sensor
- ◆ Optional inverter variable speed
- ◆ Optional blade tension gauge

MODEL	BMT 380FH / BMT 380FHV
Capacity (90°)	● 380 mm, ■ 280 x 280 mm, ■ 230 x 410 mm
Blade Size	27 x 0.9 x 4265 mm
Blade Speed	6 steps, 14~76 mpm Vari. speed, 21~100 mpm
Blade Motor	3 HP
Packing Size	2280 x 955 x 1485 mm
N.W. / G.W.	1100 kgs / 1200 kgs

*Specifications are subject to change without prior notice.

BMT 380SFA

- Fully Automatic Bandsaw / Pivot Type -



FEATURES:

- ◆ Swivel arm
- ◆ Coolant system
- ◆ Automatic saw blade breakage power off system
- ◆ Hydraulic dual vise
- ◆ Hydraulic chip conveyor
- ◆ Out of stock sensor
- ◆ Inverter variable speed
- ◆ Optional roller table
- ◆ Optional blade tension gauge

MODEL	BMT 380SFA
Capacity (90°)	● 380 mm, ■ 350 x 350 mm, ■ 350 x 500 mm
Capacity (45°)	● 350 mm, ■ 350 x 350 mm
Blade Size	27 x 0.9 x 4115 mm
Blade Speed	Vari. speed (inverter), 15~90 mpm
Blade Motor	3 HP
Hydraulic Motor, Tank	1 HP, 45 L
Coolant Motor, Tank	50 L
Feeding Stroke	500 mm
Packing Size	2340 x 2240 x 1710 mm
N.W. / G.W.	1350 kgs / 1590 kgs

*Specifications are subject to change without prior notice.

16.5" (420 mm) / 18" (460 mm)

BMT 420HA

- Fully Automatic Bandsaw / Double Column -



*Machine shown with optional accessories

FEATURES:

- ◆ PLC control panel
- ◆ Hydraulic clamping system
- ◆ Automatic chip conveyor
- ◆ 2M roller table
- ◆ Nesting fixture for bundle cutting
- ◆ Hydraulic blade tension
- ◆ Inverter variable speed
- ◆ Check device of saw blade breaking
- ◆ Multiple index (9 times)
- ◆ Optional full stroke cylinder

MODEL	BMT 420HA
Capacity (90°)	● 420 mm, ■ 420 x 420 mm
Blade Size	41 x 1.3 x 4880 mm
Blade Speed	Vari. speed (inverter), 20~100 mpm
Blade Motor	7.5 HP
Hydraulic Motor, Tank	2 HP, 90 L
Coolant Motor, Tank	1/4 HP, 110 L
Bundle Cutting (H x W)	200~350 x 100~200 mm
Feeding Stroke	500 mm x 9
Table Height	800 mm
Machine Size	2600 x 2150 x 1902 mm
N.W.	2500 kgs

*Specifications are subject to change without prior notice.

BMT 1824SSAV

- Semi-Automatic Bandsaw / Pivot Type -



FEATURES:

- ◆ Swivel arm
- ◆ Blade tension gauge
- ◆ Hydraulic vise
- ◆ Vise pressure regulator
- ◆ Digital blade speed indicator
- ◆ Set bow height on the control panel
- ◆ Power driven chip brush
- ◆ Abnormal warning lights

MODEL	BMT 1824SSAV
Capacity (90°)	● 460 mm, ■ 460 x 460 mm, ■ 380 x 610 mm
Capacity (45°)	● 380 mm, ■ 380 x 380 mm
Capacity (60°)	● 260 mm, ■ 260 x 260 mm
Blade Size	41 x 1.3 x 5330 mm
Blade Speed	Vari. speed, 20~85 mpm
Blade Motor	5 HP
Hydraulic Motor, Tank	1 HP, 15 L
Coolant Motor, Tank	1/6 HP, 55 L
Table Height	800 mm
Packing Size	2850 x 1150 x 2170 mm
N.W. / G.W.	1420 kgs / 1583 kgs

*Specifications are subject to change without prior notice.

18" (460 mm)

BMT 460DSA / BMT 460DSAE / BMT 460DSAP

- Semi-Automatic Bandsaw / Pivot Type -



*Machine shown with optional accessories

FEATURES:

- ◆ Dual miter cutting
- ◆ Blade tension gauge
- ◆ Manual vise movement
- ◆ Vise pressure regulator
- ◆ Digital blade speed indicator
- ◆ Set bow height on the control panel
- ◆ Abnormal warning lights
- ◆ Optional hydraulic blade tension
- ◆ Optional vertical vise for bundle cutting
- ◆ Optional laser guide line device

MODEL	BMT 460DSA / BMT 460DSAE / BMT 460DSAP
Capacity (90°)	● 460 mm, ■ 460 x 460 mm, ■ 440 x 600 mm
Capacity (45°)	● 445 mm, ■ 445 x 445 mm
Capacity (60°)	● 295 mm, ■ 295 x 295 mm
Capacity (L45°)	● 445 mm, ■ 445 x 445 mm
Capacity (L60°)	● 295 mm, ■ 295 x 295 mm
Blade Size	41 x 1.3 x 5330 mm
Blade Speed	Vari. speed, 32~96 mpm @ 60Hz
Blade Motor	5 HP
Hydraulic Motor, Tank	1 HP, 15 L
Coolant Motor, Tank	1/6 HP, 55 L
Packing Size	2830 x 1140 x 1860 mm for BMT 460DSA 2810 x 1130 x 1870 mm for others
N.W. / G.W.	1320 kgs / 1500 kgs for BMT 460DSA 1310 kgs / 1470 kgs for others

*Specifications are subject to change without prior notice.

BMT 460SH

- Semi-Automatic Bandsaw / Pivot Type -



FEATURES:

- ◆ Dual miter cutting
- ◆ Coolant system
- ◆ Automatic saw blade breakage power off system
- ◆ Hydraulic vise
- ◆ Inverter variable speed
- ◆ Digital blade speed indicator
- ◆ Frame swiveling accelerator
- ◆ Motor driven swivel frame & working table
- ◆ Optional blade tension gauge
- ◆ Optional roller table

MODEL	BMT 460SH
Capacity (90°)	● 460 mm, ■ 460 x 460 mm, ■ 400 x 700 mm
Capacity (45°)	● 460 mm, ■ 460 x 460 mm, ■ 340 x 500 mm
Capacity (60°)	● 350 mm, ■ 330 x 330 mm
Capacity (L45°)	● 460 mm, ■ 460 x 460 mm, ■ 340 x 500 mm
Capacity (L60°)	● 350 mm, ■ 330 x 330 mm
Blade Size	41 x 1.3 x 5100 mm
Blade Speed	Vari. speed (inverter), 15~90 mpm
Blade Motor	5 HP
Packing Size	2780 x 1200 x 1600 mm
N.W. / G.W.	1260 kgs / 1440 kgs

*Specifications are subject to change without prior notice.

18" (460 mm)

BMT 460DSARL

- Semi-Automatic Bandsaw / Pivot Type -



*Machine shown with optional accessories

BMT 460HDSA

- Semi-Automatic Bandsaw / Double Column -



FEATURES:

- ◆ Dual miter cutting
- ◆ Angle setting from control panel
- ◆ Blade tilt 5° for H beam easy cutting
- ◆ Inverter variable speed
- ◆ Auto-shifted vise movement
- ◆ Hydraulic blade tension
- ◆ Material height auto-detecting feeler

FEATURES:

- ◆ Dual miter cutting
- ◆ Manual swivel saw bow movement
- ◆ Vise clamping pressure regulator
- ◆ Inverter variable speed
- ◆ Manual vise movement
- ◆ Hydraulic blade tension
- ◆ Material height auto-detecting feeler

MODEL	BMT 460DSAL / BMT 460DSARL
Capacity (90°)	● 460 mm, ■ 460 x 460 mm, ■ 420 x 820 mm
Capacity (45°)	● 460 mm, ■ 420 x 420 mm, ■ 420 x 550 mm
Capacity (60°)	● 350 mm, ■ 330 x 330 mm, ■ 460 x 280 mm
Capacity (L45°)	● 460 mm, ■ 420 x 420 mm, ■ 420 x 550 mm
Blade Size	41 x 1.3 x 6185 mm
Blade Speed	Vari. speed (inverter), 30~85 mpm
Blade Motor	5 HP
Hydraulic Motor	2 HP
Coolant Motor	1/6 HP
Table Height	760 mm
Packing Size	3910 x 1390 x 2265 mm
N.W. / G.W.	2750 kgs / 3030 kgs

*Specifications are subject to change without prior notice.

MODEL	BMT 460HDSA / BMT 460DSAR
Capacity (90°)	● 460 mm, ■ 460 x 460 mm, ■ 460 x 820 mm
Capacity (45°)	● 460 mm, ■ 460 x 500 mm
Capacity (L45°)	● 460 mm, ■ 460 x 460 mm, ■ 460 x 500 mm
Capacity (L60°)	● 330 mm, ■ 310 x 310 mm
Blade Size	41 x 1.3 x 6090 mm
Blade Speed	Vari. speed (inverter), 20~105 mpm
Blade Motor	5 HP
Hydraulic Motor	1 HP
Coolant Motor	1/6 HP
Table Height	890 mm
Packing Size	3030 x 1150 x 2500 mm
N.W. / G.W.	2285 kgs / 2485 kgs

*Specifications are subject to change without prior notice.

BMT 5046SA

- Semi-Automatic Bandsaw / Double Column -



*Machine shown with optional accessories

FEATURES:

- ◆ Hydraulic blade tension device
- ◆ Manual feeding roller
- ◆ Inverter variable speed
- ◆ Hydraulic carbide blade guides
- ◆ Broken blade detection sensor
- ◆ Optional hydraulic chip conveyor
- ◆ Chip drawer
- ◆ HMI control panel

MODEL	BMT 5046SA
Capacity (90°)	● 460 mm, ■ 460 x 500 mm
Blade Size	41 x 1.1 x 5450 mm
Blade Speed	Vari. speed (inverter), 30~85 mpm
Blade Motor	7.5 HP
Hydraulic Motor, Tank	2 HP, 60 L
Coolant Motor, Tank	1/4 HP, 85 L
Table Height	820 mm
Packing Size	2825 x 1460 x 2045 mm
N.W.	2300 kgs

*Specifications are subject to change without prior notice.

BMT 460SA

- Semi-Automatic Bandsaw / Double Column -



FEATURES:

- ◆ PLC control panel
- ◆ Hydraulic lift up roller
- ◆ Hydraulic clamping system
- ◆ Hydraulic blade tension device
- ◆ Inverter variable speed
- ◆ Check device of saw blade breaking
- ◆ Hydraulic carbide fixture
- ◆ Control rod of height
- ◆ Power driven blade brush

MODEL	BMT 460SA
Capacity (90°)	● 460 mm, ■ 460 x 460 mm (Min. ● 15 mm, ■ 15 x 15 mm)
Blade Size	41 x 1.3 x 5450 mm
Blade Speed	Vari. speed (inverter), 20~100 mpm
Blade Motor	7.5 HP
Hydraulic Motor, Tank	2 HP, 70 L
Coolant Motor, Tank	1/4 HP, 110 L
Table Height	800 mm
Machine Size	2710 x 1360 x 2050 mm
N.W.	2150 kgs

*Specifications are subject to change without prior notice.

18" (460 mm)

BMT 5546SA

- Semi-Automatic Bandsaw / Double Column -



*Machine shown with optional accessories

FEATURES:

- ◆ PLC control panel
- ◆ Hydraulic lift up roller
- ◆ Hydraulic clamping system
- ◆ Hydraulic blade tension device
- ◆ Inverter variable speed
- ◆ Check device of saw blade breaking
- ◆ Hydraulic carbide fixture
- ◆ Control rod of height
- ◆ Power driven blade brush

MODEL	BMT 5546SA
Capacity (90°)	● 460 mm, ■ 550 x 460 mm (Min. ● 15 mm, ■ 15 x 15 mm)
Blade Size	41 x 1.3 x 5550 mm
Blade Speed	Vari. speed (inverter), 20~100 mpm
Blade Motor	7.5 HP
Hydraulic Motor, Tank	2 HP, 70 L
Coolant Motor, Tank	1/4 HP, 110 L
Table Height	800 mm
Machine Size	2800 x 1300 x 2040 mm
N.W.	2350 kgs

*Specifications are subject to change without prior notice.

BMT 1824FA

- Fully Automatic Bandsaw / Pivot Type -



FEATURES:

- ◆ Swivel arm
- ◆ Touch screen and length encoder
- ◆ Hydraulic blade tension
- ◆ Vise pressure regulator
- ◆ Inverter variable speed
- ◆ Power chip brush
- ◆ Auto chip conveyor
- ◆ Bow height set manually
- ◆ Vertical vises for bundle cutting

MODEL	BMT 1824FA
Capacity (90°)	● 460 mm, ■ 460 x 460 mm, ■ 380 x 600 mm
Capacity (45°)	● 380 mm, ■ 380 x 380 mm
Blade Size	41 x 1.3 x 5330 mm
Blade Speed	Vari. speed (inverter), 30~85 mpm
Blade Motor	5 HP AC motor
Hydraulic Motor, Tank	1 HP, 15 L
Coolant Motor, Tank	1/6 HP, 55 L
Feeding Stroke	700 mm
Table Height	925 mm
Packing Size	2750 x 2270 x 1950 mm
N.W. / G.W.	2150 kgs / 2465 kgs

*Specifications are subject to change without prior notice.

BMT 460HA

- Fully Automatic Bandsaw / Double Column -



*Machine shown with optional accessories

FEATURES:

- ◆ PLC control panel
- ◆ Hydraulic clamping system
- ◆ Automatic chip conveyor
- ◆ 2M roller table
- ◆ Nesting fixture for bundle cutting
- ◆ Hydraulic blade tension
- ◆ Inverter variable speed
- ◆ Check device of saw blade breaking
- ◆ Multiple index (9 times)

MODEL	BMT 460HA
Capacity (90°)	● 460 mm, ■ 460 x 460 mm
Blade Size	41 x 1.3 x 5450 mm
Blade Speed	Vari. speed (inverter), 20~100 mpm
Blade Motor	7.5 HP
Hydraulic Motor, Tank	2 HP, 90 L
Coolant Motor, Tank	1/4 HP, 110 L
Bundle Cutting (H x W)	200~350 x 130~240 mm
Feeding Stroke	500 mm x 9
Table Height	800 mm
Machine Size	2800 x 2200 x 2050 mm
N.W.	3200 kgs

*Specifications are subject to change without prior notice.

BMT 5046HA

- Fully Automatic Bandsaw / Double Column -



FEATURES:

- ◆ Color touchscreen
- ◆ Precise length encoder
- ◆ Hydraulic blade tension device
- ◆ Inverter variable speed
- ◆ 10 cutting presets memory
- ◆ Automatic chip conveyor
- ◆ Multi-language interface
- ◆ Full stroke hydraulic vise
- ◆ Broken blade detection sensor
- ◆ Power driven wire brush
- ◆ Optional nesting fixture for bundle cutting
- ◆ Optional vise pressure regulator

MODEL	BMT 5046HA
Capacity (90°)	● 460 mm, ■ 460 x 500 mm
Blade Size	41 x 1.3 x 5450 mm
Blade Speed	Vari. speed (inverter), 30~85 mpm
Blade Motor	7.5 HP
Hydraulic Motor, Tank	2 HP, 60 L
Coolant Motor, Tank	1/4 HP, 100 L
Bundle Cutting (H x W)	195~310 x 120~230 mm
Cut Off Length	over 10 mm
Feeding Stroke	500 mm
Minimum No Material Detecting	32 mm
Minimum Residual Work Length	120 mm
Table Height	850 mm
Packing Size	2735 x 2260 x 2185 mm
N.W. / G.W.	3090 kgs / 3485 kgs

*Specifications are subject to change without prior notice.

20" (500~510 mm)

BMT 500FAL

- Fully Automatic Bandsaw / Double Column -



FEATURES:

- ◆ Specialized in pipe bundle cutting
- ◆ HMI control panel
- ◆ Helical gear reducer
- ◆ 10 presets setting
- ◆ Feeding vise by servo motor
- ◆ Saw bow down feed control by hydraulic precise vise
- ◆ Inverter variable speed

MODEL	BMT 500FAL
Capacity (90°)	● 500 mm, ■ 500 x 500 mm, ■ 500 x 600 mm
Blade Size	41 x 1.3 x 6060 mm
Blade Speed	Vari. speed (inverter), 30~105 mpm
Blade Motor	7.5 HP
Feeding Stroke	700 mm
Table Height	830 mm
Packing Size	3160 x 2300 x 2220 mm
N.W. / G.W.	4200 kgs / 4560 kgs

*Specifications are subject to change without prior notice.

BMT 500DSA

- Semi-Automatic Bandsaw / Pivot Type -



*Machine shown with optional accessories

FEATURES:

- ◆ Dual miter cutting
- ◆ Semi-automatic saw bow lifting
- ◆ Hydraulic vise
- ◆ Optional auto swivel
- ◆ Optional reducer for auto swivel

MODEL	BMT 500DSA
Capacity (90°)	● 508 mm, ■ 508 x 508 mm, ■ 508 x 660 mm
Capacity (45°)	● 508 mm, ■ 508 x 508 mm, ■ 260 x 590 mm
Capacity (60°)	● 380 mm, ■ 380 x 380 mm, ■ 360 x 460 mm
Capacity (L45°)	● 508 mm, ■ 508 x 508 mm, ■ 260 x 590 mm
Capacity (L60°)	● 380 mm, ■ 380 x 380 mm, ■ 360 x 460 mm
Blade Size	41 x 1.3 x 5890 mm
Blade Speed	Vari. speed, 32~96 mpm
Blade Motor	5 HP
Hydraulic Motor	2 HP
Coolant Motor	1/8 HP
Packing Size	2930 x 1140 x 1981 mm
N.W. / G.W.	1590 kgs / 1800 kgs
Container Loads	4 sets / 20'

*Specifications are subject to change without prior notice.

21" (530~550 mm)

BMT 530DSA

- Semi-Automatic Bandsaw / Pivot Type -



*Machine shown with optional accessories

FEATURES:

- ◆ Dual miter cutting
- ◆ Easily set saw height from control panel
- ◆ Inverter variable speed
- ◆ Hydraulic blade tension device
- ◆ Vise clamping pressure regulator
- ◆ Swiveling control panel
- ◆ Power chip brush
- ◆ Malfunction warning lights

MODEL	BMT 530DSA
Capacity (90°)	● 530 mm, ■ 530 x 530 mm, ■ 335 x 700 mm
Capacity (45°)	● 490 mm, ■ 435 x 435 mm, ■ 300 x 490 mm
Capacity (60°)	● 335 mm, ■ 320 x 320 mm, ■ 305 x 400 mm
Capacity (L45°)	● 480 mm, ■ 435 x 435 mm, ■ 300 x 480 mm
Capacity (L60°)	● 335 mm, ■ 320 x 320 mm, ■ 305 x 400 mm
Blade Size	41 x 1.3 x 6030 mm
Blade Speed	Vari. speed (inverter), 20~85 mpm
Blade Motor	7.5 HP AC motor
Hydraulic Motor, Tank	1 HP
Coolant Motor, Tank	1/6 HP, 150 L
Bundle Cutting (H x W)	90~300 x 200~420 mm
Table Height	923 mm
Packing Size	3302 x 1135 x 2034 mm
N.W. / G.W.	1880 kgs / 2048 kgs

*Specifications are subject to change without prior notice.

BMT 7055SA

- Semi-Automatic Bandsaw / Double Column -



FEATURES:

- ◆ PLC control panel
- ◆ Hydraulic lift up roller
- ◆ Hydraulic clamping system
- ◆ Hydraulic blade tension device
- ◆ Inverter variable speed
- ◆ Check device of saw blade breaking
- ◆ Hydraulic carbide fixture
- ◆ Control rod of height
- ◆ Power driven blade brush

MODEL	BMT 7055SA
Capacity (90°)	● 550 mm, ■ 700 x 550 mm (Min. ● 15 mm, ■ 15 x 15 mm)
Blade Size	41 x 1.3 x 6280 mm
Blade Speed	Vari. speed (inverter), 20~100 mpm
Blade Motor	7.5 HP
Hydraulic Motor, Tank	2 HP, 70 L
Coolant Motor, Tank	1/4 HP, 110 L
Table Height	800 mm
Machine Size	2880 x 1480 x 1970 mm
N.W.	2850 kgs

*Specifications are subject to change without prior notice.

21" (530~550 mm) / 22" (560~580 mm)

BMT 550HA

- Fully Automatic Bandsaw / Double Column -



BMT 560SSAR

- Semi-Automatic Bandsaw / Pivot Type-



*Machine shown with optional accessories

BMT 560DSAR

- Semi-Automatic Bandsaw / Pivot Type-



*Machine shown with optional accessories

BMT 6056HA

- Fully Automatic Bandsaw / Double Column -

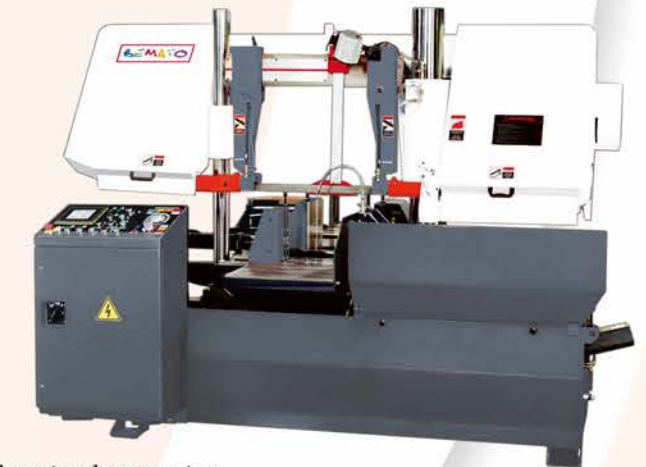

FEATURES:

- ◆ PLC control panel
- ◆ Hydraulic clamping system
- ◆ Automatic chip conveyor
- ◆ 2M roller table
- ◆ Nesting fixture for bundle cutting
- ◆ Hydraulic blade tension
- ◆ Inverter variable speed
- ◆ Check device of saw blade breaking
- ◆ Multiple index (9 times)

FEATURES:

- ◆ Quickly down material feeler
- ◆ Hydraulic blade tension
- ◆ Motor driven chip brush
- ◆ Inverter variable speed
- ◆ Cutting start noise abatement device
- ◆ Blade tilt 6.5° for section steel or steel plate easy cutting
- ◆ Set angle cutting (R45°) on screen and auto-swiveling
- ◆ Swiveling drive by servo motor and brake position by hydraulic brake
- ◆ Optional vise pressure regulator
- ◆ Abnormal warning showing on screen
- ◆ Blade guide arm auto-moving
- ◆ Hydraulic carbide guides device

FEATURES:

- ◆ Quickly down material feeler
- ◆ Hydraulic blade tension
- ◆ Motor driven chip brush
- ◆ Hydraulic carbide guides device
- ◆ Blade tilt 6.5° for section steel or steel plate easy cutting
- ◆ Set angle cutting (R/L45° L60°) on screen and auto-swiveling
- ◆ Swiveling drive by servo motor and brake position by hydraulic brake
- ◆ Optional vise pressure regulator
- ◆ Cutting start noise abatement device
- ◆ Abnormal warning showing on screen
- ◆ Inverter variable speed
- ◆ Blade guide arm auto-moving

FEATURES:

- ◆ Color touchscreen
- ◆ Precise length encoder
- ◆ Hydraulic blade tension device
- ◆ Inverter variable speed
- ◆ 10 cutting presets memory
- ◆ Automatic chip conveyor
- ◆ Multi-language interface
- ◆ Full stroke hydraulic vise
- ◆ Broken blade detection sensor
- ◆ Power driven wire brush
- ◆ Optional nesting fixture for bundle cutting
- ◆ Optional vise pressure regulator

MODEL	BMT 550HA
Capacity (90°)	● 550 mm, ■ 550 x 550 mm
Blade Size	41 x 1.3 x 5980 mm
Blade Speed	Vari. speed (inverter), 20~100 mpm
Blade Motor	7.5 HP
Hydraulic Motor, Tank	2 HP, 100 L
Coolant Motor, Tank	1/4 HP, 110 L
Bundle Cutting (H x W)	230~400 x 120~270 mm
Feeding Stroke	500 mm x 9
Table Height	800 mm
Machine Size	3060 x 2270 x 2200 mm
N.W.	3450 kgs

MODEL	BMT 560SSAR
Capacity (90°)	● 560 mm, ■ 560 x 950 mm
Capacity (R45°)	● 560 mm, ■ 560 x 600 mm
Blade Size	41 x 1.3 x 7880 mm
Blade Speed	Vari. speed (inverter), 30~110 mpm
Blade Motor	7.5 HP
Hydraulic Motor, Tank	2 HP, 75 L
Coolant Pump, Tank	1/4 HP, 155 L
Table Height	830 mm
Packing Size	4250 x 2100 x 2100 mm
N.W. / G.W.	4500 kgs / 4700 kgs

*Specifications are subject to change without prior notice.

MODEL	BMT 560DSAR
Capacity (90°)	● 560 mm, ■ 560 x 950 mm
Capacity (R45°)	● 560 mm, ■ 560 x 600 mm
Capacity (L45°)	● 560 mm, ■ 560 x 600 mm
Capacity (L60°)	● 400 mm, ■ 560 x 400 mm
Blade Size	41 x 1.3 x 7880 mm
Blade Speed	Vari. speed (inverter), 30~110 mpm
Blade Motor	7.5 HP
Hydraulic Motor, Tank	2 HP, 75 L
Coolant Pump, Tank	1/4 HP, 155L
Table Height	830 mm
Packing Size	4250 x 2100 x 2100 mm
N.W. / G.W.	4500 kgs / 4700 kgs

*Specifications are subject to change without prior notice.

MODEL	BMT 6056HA
Capacity (90°)	● 560 mm, ■ 600 x 560 mm
Blade Size	54 x 1.6 x 6600 mm
Blade Speed	Vari. speed (inverter), 30~85 mpm
Blade Motor	10 HP
Hydraulic Motor, Tank	3 HP, 90 L
Coolant Motor, Tank	1/4 HP, 120 L
Bundle Cutting (H x W)	230~400 x 120~270 mm
Cut Off Length	over 10 mm
Feeding Stroke	500 mm
Minimum No Material Detecting	110 mm
Minimum Residual Work Length	120 mm
Table Height	810 mm
Packing Size	3270 x 2195 x 2280 mm
N.W. / G.W.	4500 kgs / 5000 kgs

*Specifications are subject to change without prior notice.

22" (560~580 mm) / 25" (620~650 mm)

BMT 580HANC

- Fully Automatic Bandsaw / Double Column -



*Machine shown with optional accessories

FEATURES:

- ◆ NC control panel
- ◆ Automatic chip cleaning
- ◆ Check device of saw blade breaking
- ◆ Rapid downfeed sensing rod
- ◆ Synchronized adjustment of blade guide
- ◆ Feed roller table
- ◆ Hydraulic guiding device of saw blade
- ◆ Precision linear way
- ◆ Hydraulic tension device of saw blade breaking

MODEL	BMT 580HANC
Capacity (90°)	● 580 mm, ■ 620 x 580 mm
Blade Size	54 x 1.6 x 7000 mm
Blade Speed	Vari. speed (inverter), 20~85 mpm
Blade Motor	10 HP
Hydraulic Motor, Tank	3 HP, 85 L
Coolant Motor, Tank	1/4 HP, 110 L
Feeding Stroke	400 mm
Table Height	810 mm
Machine Size	3500 x 2120 x 2320 mm
N.W.	5100 kgs

*Specifications are subject to change without prior notice.

BMT 7062NC

- Fully Automatic Bandsaw / Double Column -

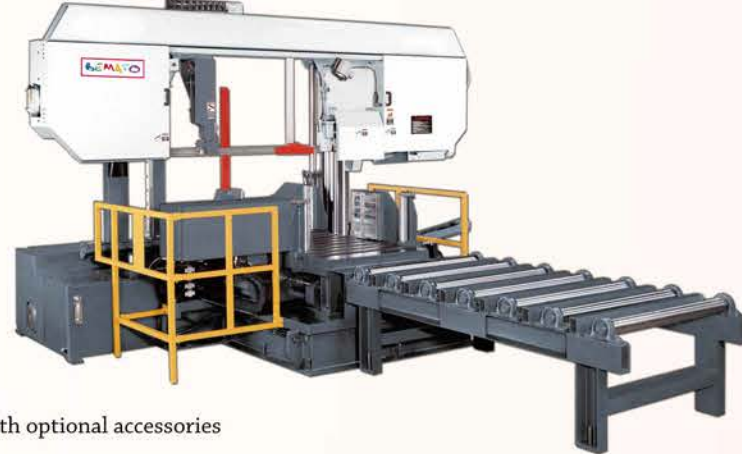

FEATURES:

- ◆ NC control panel
- ◆ Automatic chip cleaning
- ◆ Check device of saw blade breaking
- ◆ Rapid downfeed sensing rod
- ◆ Synchronized adjustment of blade guide
- ◆ Feed roller table
- ◆ Hydraulic guiding device of saw blade
- ◆ Precision linear way
- ◆ Hydraulic tension device of saw blade breaking

MODEL	BMT 7062NC
Capacity (90°)	● 620 mm, ■ 700 x 620 mm
Blade Size	54 x 1.6 x 7600 mm
Blade Speed	Vari. speed (inverter), 15~100 mpm
Blade Motor	10 HP
Hydraulic Motor, Tank	3 HP, 100 L
Coolant Motor, Tank	1/4 HP, 140 L
Feeding Stroke	500 mm
Table Height	650 mm
Machine Size	3800 x 2300 x 2200 mm
N.W.	7000 kgs

*Specifications are subject to change without prior notice.

BMT 650AR

- Semi-Automatic Bandsaw / Pivot Type-



*Machine shown with optional accessories

FEATURES:

- ◆ Quickly down material feeler
- ◆ Hydraulic blade tension
- ◆ Motor driven chip brush
- ◆ Inverter variable speed
- ◆ Cutting start noise abatement device
- ◆ Blade guide arm auto-moving
- ◆ Blade tilt 6.5° for section steel or steel plate easy cutting
- ◆ Optional vise pressure regulator
- ◆ Optional hydraulic vertical press vise

MODEL	BMT 650AR
Capacity (90°)	● 650 mm, ■ 650 x 1100 mm
Blade Size	54 x 1.6 x 8700 mm
Blade Speed	Vari. speed (inverter), 30~110 mpm
Blade Motor	10 HP
Hydraulic Motor, Tank	3 HP, 80 L
Coolant Pump, Tank	1/4 HP, 120 L
Table Height	830 mm
Packing Size	4300 x 1510 x 2250 mm
N.W. / G.W.	4300 kgs

*Specifications are subject to change without prior notice.

BMT 650DSAR / BMT 650DFAR

- Semi-Automatic Bandsaw / Pivot Type -



FEATURES:

- ◆ Dual miter cutting, saw bow rotates automatically
- ◆ Linear guides and servo feeding for BMT 650DFAL
- ◆ Hydraulic blade carbide guides
- ◆ Hydraulic blade tension control device
- ◆ Inverter variable speed
- ◆ Power drive swarf brush
- ◆ Hydraulic chip conveyor
- ◆ Saw bow angle position by hydraulic motor and brake
- ◆ Blade guide arm slides automatically to vise clamping position
- ◆ Blade tilt 6.5 degree design for cutting H beam or wide workpiece

MODEL	BMT 650DSAR / BMT 650DFAR
Capacity (90°)	● 650 mm, ■ 650 x 1100 mm
Capacity (R45°)	● 650 mm, ■ 650 x 650 mm
Capacity (L45°)	● 650 mm, ■ 650 x 650 mm
Capacity (L60°)	● 650 mm, ■ 650 x 400 mm
Blade Size	54 x 1.6 x 8700 mm
Blade Speed	30~110 mpm
Blade Motor	10 HP
Hydraulic Motor, Tank	3 HP, 75 L
Coolant Pump, Tank	1/4 HP, 180 L
Table Height	830 mm
Packing Size	4550 x 2270 x 2560 mm
N.W. / G.W.	5200 kgs / 5400 kgs

*Specifications are subject to change without prior notice.

27.6" (700 mm) / 31.5" (800 mm)

BMT 7670SA

- Semi-Automatic Bandsaw / Double Column -



*Machine shown with optional accessories

BMT 810AR

- Semi-Automatic Bandsaw / Pivot Type -



FEATURES:

- ◆ Quickly down material feeler
- ◆ Hydraulic blade tension
- ◆ Motor driven chip brush
- ◆ Inverter variable speed
- ◆ Cutting start noise abatement device
- ◆ Blade guide arm auto-moving
- ◆ Hydraulic carbide guides device
- ◆ Blade tilt 6.5° for section steel or steel plate easy cutting
- ◆ Optional vise pressure regulator
- ◆ Optional hydraulic vertical press vise

FEATURES:

- ◆ PLC control panel
- ◆ Hydraulic lift up roller
- ◆ Hydraulic clamping system
- ◆ Hydraulic blade tension device
- ◆ Inverter variable speed
- ◆ Check device of saw blade breaking
- ◆ Hydraulic carbide fixture
- ◆ Control rod of height
- ◆ Power driven blade brush

MODEL	BMT 7670SA
Capacity	● 700 mm, ■ 760 x 700 mm (Min. ● 170 mm, ■ 170 x 170 mm)
Blade Size	54 x 1.6 x 7200 mm
Blade Speed	Vari. speed (inverter), 20~85 mpm
Blade Motor	10 HP
Hydraulic Motor, Tank	2 HP, 80 L
Coolant Motor, Tank	1/4 HP, 120 L
Hydraulic Lift Up Roller With Power Feeding Table	1/2 HP (opt.)
Table Height	680 mm
Machine Size	3600 x 1450 x 2320 mm
N.W.	3850 kgs

*Specifications are subject to change without prior notice.

MODEL	BMT 810AR
Capacity (90°)	● 800 mm, ■ 800 x 1100 mm
Blade Size	54 x 1.6 x 9840 mm
Blade Speed	Vari. speed (inverter), 30~110 mpm
Blade Motor	15 HP
Hydraulic Motor, Tank	3 HP, 80 L
Coolant Pump, Tank	1/4 HP, 140 L
Table Height	830 mm
Packing Size	4500 x 1600 x 2500 mm
N.W. / G.W.	5400 kgs

*Specifications are subject to change without prior notice.

BMT 800SAT

- Semi-Automatic Bandsaw / Double Column -



*Machine shown with optional accessories

FEATURES:

- ◆ Hydraulic clamping vise
- ◆ Hydraulic blade tension device
- ◆ Inverter variable speed
- ◆ LED display of blade speed
- ◆ Check device of saw blade breaking
- ◆ Hydraulic carbide blade guide system
- ◆ Control rod of height
- ◆ Power driven blade brush
- ◆ Projector for marking

MODEL	BMT 800SAT
Capacity	● 800 mm, ■ 800 x 800 mm
Blade Size	54 x 1.6 x 8300 mm
Blade Speed	Vari. speed (inverter), 20~80 mpm
Blade Motor	10 HP
Hydraulic Motor, Tank	3 HP, 120 L
Coolant Motor, Tank	1/4 HP, 180 L
Table Height	650 mm
Machine Size	4090 x 2300 x 2350 mm
N.W.	7800 kgs

*Specifications are subject to change without prior notice.

BMT 1080SAT

- Semi-Automatic Bandsaw / Double Column -



FEATURES:

- ◆ Hydraulic clamping vise
- ◆ Hydraulic blade tension device
- ◆ Inverter variable speed
- ◆ LED display of blade speed
- ◆ Check device of saw blade breaking
- ◆ Hydraulic carbide blade guide system
- ◆ Control rod of height
- ◆ Power driven blade brush
- ◆ Projector for marking

MODEL	BMT 1080SAT
Capacity	● 800 mm, ■ 1000 x 800 mm
Blade Size	67 x 1.6 x 8800 mm
Blade Speed	Vari. speed (inverter), 20~80 mpm
Blade Motor	15 HP
Hydraulic Motor, Tank	3 HP, 120 L
Coolant Motor, Tank	1/4 HP, 200 L
Table Height	650 mm
Machine Size	4000 x 2250 x 2350 mm
N.W.	9500 kgs

*Specifications are subject to change without prior notice.

31.5" (800 mm)

BMT 9080NCL

- Fully Automatic Bandsaw / Double Column -



*Machine shown with optional accessories

FEATURES:

- ◆ Newly upgraded HMI control panel
- ◆ Advanced operation assistance systems, with built-in 12 different error conditions
- ◆ Linear guides for saw-bow movement and feeding
- ◆ Precision positioning control by magnetic scale on saw-bow movement
- ◆ Blade guide arm automatically slides to vise clamping position
- ◆ Helical gear reducer enhances torque output under heavy working loads
- ◆ Blade broken detection device
- ◆ Blade tilt detect sensor
- ◆ Floating vise and wash down device
- ◆ Inverter variable speed

MODEL	BMT 9080NCL
Capacity	● 800 mm, ■ 800 x 800 mm, ■ 800 x 900 mm
Blade Size	54 x 1.6 x 8900 mm
Blade Speed	Vari. speed (inverter), 25~85 mpm
Blade Motor	10 HP
Hydraulic Motor, Tank	5 HP, 120 L
Coolant Pump, Tank	1/2 HP, 200 L
Table Height	920 mm
Packing Size	4700 x 2320 x 2400 mm
N.W. / G.W.	11100 kgs

*Specifications are subject to change without prior notice.

BMT 1080NC

- Fully Automatic Bandsaw / Double Column -



FEATURES:

- ◆ NC control panel
- ◆ Automatic chip cleaning
- ◆ Check device of saw blade breaking
- ◆ Rapid downfeed sensing rod
- ◆ Synchronized adjustment of blade guide
- ◆ Feed roller table
- ◆ Hydraulic guiding device of saw blade
- ◆ Precision linear way
- ◆ Hydraulic tension device of saw blade breaking

MODEL	BMT 1080NC
Capacity	● 800 mm, ■ 1000 x 800 mm
Blade Size	67 x 1.6 x 8800 mm
Blade Speed	Vari. speed (inverter), 20~80 mpm
Blade Motor	15 HP
Hydraulic Motor, Tank	3 HP, 100 L
Coolant Motor, Tank	1/4 HP, 140 L
Feeding Stroke	410 mm
Table Height	680 mm
Machine Size	4100 x 2090 x 2360 mm
N.W.	9500 kgs

*Specifications are subject to change without prior notice.

43.3" (1100 mm) / 51.2" (1300 mm)

BMT 1100SAT

- Fully Automatic Bandsaw / Double Column -



*Machine shown with optional accessories

FEATURES:

- ◆ Hydraulic clamping vise
- ◆ Hydraulic blade tension device
- ◆ Inverter variable speed
- ◆ LED display of blade speed
- ◆ Check device of saw blade breaking
- ◆ Hydraulic carbide blade guide system
- ◆ Control rod of height
- ◆ Power driven blade brush
- ◆ Projector for marking

MODEL	BMT 1100SAT
Capacity (90°)	● 1100 mm, ■ 1100 x 1100 mm
Blade Size	67 x 1.6 x 9800 mm
Blade Speed	Vari. speed (inverter), 20~80 mpm
Blade Motor	15 HP
Hydraulic Motor, Tank	5 HP, 120 L
Coolant Motor, Tank	1/4 HP, 280 L
Table Height	680 mm
Packing Size	4800 x 2235 x 2950 mm
N.W.	11500 kgs

*Specifications are subject to change without prior notice.

BMT 1300SAT

- Semi-Automatic Bandsaw / Double Column -



FEATURES:

- ◆ Hydraulic clamping vise
- ◆ Hydraulic blade tension device
- ◆ Inverter variable speed
- ◆ LED display of blade speed
- ◆ Check device of saw blade breaking
- ◆ Hydraulic carbide blade guide system
- ◆ Control rod of height
- ◆ Power driven blade brush
- ◆ Projector for marking

MODEL	BMT 1300SAT
Capacity (90°)	● 1300 mm, ■ 1300 x 1300 mm
Blade Size	80 x 1.6 x 12300 mm
Blade Speed	Vari. speed (inverter), 15~80 mpm
Blade Motor	20 HP
Hydraulic Motor, Tank	5 HP, 160 L
Coolant Motor, Tank	1/4 HP, 400 L
Table Height	680 mm
Packing Size	5800 x 2840 x 3570 mm
N.W.	18410 kgs

*Specifications are subject to change without prior notice.

14" (360 mm) ~ 24" (600 mm)

BMT 360CNC / BMT 460CNC / BMT 600CNC

- CNC Fully Automatic Bandsaw / Double Column -



*Machine shown with optional accessories

FEATURES:

- ◆ Double hydraulic clamping vise
- ◆ Automatic chip conveyor
- ◆ Inverter variable speed
- ◆ Automatic height control and fast approach
- ◆ Check device of saw blade breaking
- ◆ Hydraulic blade tension
- ◆ Linear guide way for guide arm
- ◆ CNC + HMI control
- ◆ Deviation detector
- ◆ Flushing hose for machine cleaning
- ◆ High efficiency reducer

MODEL	BMT 360CNC	BMT 460CNC	BMT 600CNC
Capacity	● 15~360 mm, ■ 400 x 360 mm	● 15~460 mm, ■ 500 x 460 mm	● 200~600 mm, ■ 700 x 600 mm
Blade Size	41 x 1.3 x 4880 mm	54 x 1.6 x 6600 mm	67 x 1.6 x 7600 mm
Blade Speed	15~120 mpm		
Blade Tension	Hydraulic		
Blade Guide	3 pcs Carbide Guide + Hydraulic Clamping		
Blade Motor	10 HP	15 HP	20 HP
Hydraulic Motor, Tank	3 HP, 90 L		5 HP, 100 L
Coolant Motor, Tank	1/4 HP, 100 L	1/2 HP, 100 L	1/2 HP, 120 L
Wire Brush Motor	1/8 HP		
Control of Cutting Feed	Servo Motor + HMI		
Shuttle Stroke	400 mm NC Hydraulic Control		
Min. Clamping	15 mm		200 mm
Chip Conveyor	Scrape Type		
Table Height	750 mm		
Machine Size	3500 x 2200 x 2100 mm	3850 x 2200 x 2400 mm	4200 x 2200 x 2750 mm
N.W.	4500 kgs	6500 kgs	7200 kgs

*Specifications are subject to change without prior notice.

MEMO

HORIZONTAL BANDSAW — VERTICAL BANDSAW — CIRCULAR SAW — HACKSAW

BMT 30KB / BMT 36KB / BMT 45KB

- Mechanical Variable Speed / Stationary Table -



FEATURES:

- ◆ Saw blade butt welder with integrated annealing unit
- ◆ Blade shear, grinder
- ◆ Brush for cleaning lower drive wheel
- ◆ Low voltage working lamp
- ◆ Optional rip fence
- ◆ Optional miter protractor for angular cutting
- ◆ Optional electro-magnetic switch and overload protection
- ◆ Optional groove table

*Machine shown with optional accessories

BMT 40KV / BMT 50KV

- Mechanical Variable Speed / Stationary Table -



FEATURES:

*Machine shown with optional accessories

- ◆ Saw blade butt welder with integrated annealing unit
- ◆ Blade shear, grinder
- ◆ Brush for cleaning lower drive wheel
- ◆ Low voltage working lamp
- ◆ Optional rip fence
- ◆ Optional miter protractor for angular cutting
- ◆ Optional groove table

MODEL	BMT 30KB	BMT 36KB	BMT 45KB
Cutting Capacity - Throat Depth	310 mm	355 mm	455 mm
Cutting Capacity - Max. Work Height	175 mm	230 mm	255 mm
Table Size	500 x 400 mm		600 x 500 mm
Table Inclination	15° (4 ways)		
Blade Length	2520 mm	2840 mm	3490 mm
Blade Width	3~16 mm		
Blade Speed	Vari. speed (mechanical), 20~90 mpm for BMT 30KB & BMT 36KB Vari. speed (mechanical), 25~115 mpm for BMT 45KB		
Butt Welder Capacity	2.4 KVA, 3~16 mm		
Drive Motor	1/2 HP	1 HP	
Packing Size	920 x 550 x 1680 mm	940 x 560 x 1850 mm	1110 x 660 x 2020 mm
N.W. / G.W.	225 kgs / 265 kgs	245 kgs / 290 kgs	300 kgs / 350 kgs

*Specifications are subject to change without prior notice.

MODEL	BMT 40KV	BMT 50KV	BMT 60KV	BMT 100KV
Cutting Capacity - Throat Depth	410 mm	520 mm	610 mm	1010 mm
Cutting Capacity - Max. Work Height	300 mm	310 mm	340 mm	
Table Size	600 x 500 mm		600 x 500 mm 220 x 500 mm	600 x 500 mm 450 x 500 mm
Table Inclination	15° (4 ways)			
Blade Length	3350 mm	3880 mm	3970 mm	4540 mm
Blade Width	3~16 mm			
Blade Speed	Vari. speed (mechanical), Low 20~85 mpm / High 120~500 mpm			
Butt Welder Capacity	2.4 KVA, 3~16 mm			
Drive Motor	2 HP			
Packing Size	1200 x 760 x 2100 mm	1300 x 760 x 2140 mm	1420 x 760 x 2140 mm	1770 x 760 x 2140 mm
N.W. / G.W.	390 kgs / 460 kgs	435 kgs / 510 kgs	470 kgs / 550 kgs	530 kgs / 620 kgs

*Specifications are subject to change without prior notice.

BMT 360TJ / BMT 400TJ / BMT 450TJ

BMT 500TJ / BMT 600TJ

BMT 700TJ / BMT 1000TJ

- Mechanical Variable Speed / Stationary Table -



*Machine shown with optional accessories

FEATURES:

- ◆ Infinitely variable speed
- ◆ The blade tension is cushioned
- ◆ Blade welder & grinder
- ◆ Interchangeable rubber bonded saw wheels
- ◆ Brush for cleaning lower drive wheel
- ◆ Maintenance-free air pump to remove chips
- ◆ Hand wheel controlled speed
- ◆ Adjustable saw blade guides
- ◆ Change speeds while the machine is in operation, without stopping, without pulley changes
- ◆ Cast iron frame to minimize machine vibration

MODEL	BMT 360TJ	BMT 400TJ	BMT 450TJ	BMT 500TJ	BMT 600TJ	BMT 700TJ	BMT 1000TJ
Cutting Capacity - Throat Depth	360 mm	400 mm	450 mm	500 mm	600 mm	700 mm	1000 mm
Cutting Capacity - Max. Work Height	200 mm	250 mm	254 mm	360 mm	304 mm	360 mm	
Table Size	560 x 500 mm	600 x 560 mm	565 x 500 mm	740 x 680 mm			740 x 680 mm 679 x 477 mm
Table Inclination	L15° / R15° / F10° / B10°	L15° / R15° / F15° / B15°	L15° / R15° / F10° / B10°	L15° / R15° / F15° / B15°			
Blade Length	3025 mm	3290 mm	3570 mm	4055 mm	4376 mm	4090 mm	4670 mm
Blade Width	3~17 mm	3~15 mm		3~25 mm			
Blade Speed	25~117 mpm	20~376 mpm	25~117 mpm	25~456 mpm		20~394 mpm	
Drive Motor	1 HP	2 HP	1 HP	2 HP			
Machine Size	930 x 560 x 1710 mm	1015 x 630 x 1880 mm	1030 x 560 x 1870 mm	1210 x 730 x 2050 mm	1300 x 770 x 2060 mm	1420 x 750 x 2040 mm	1690 x 760 x 1890 mm
Packing Size	1030 x 700 x 1900 mm	1120 x 800 x 2000 mm	1120 x 700 x 2050 mm	1310 x 880 x 2200 mm	1430 x 880 x 2220 mm	1540 x 930 x 2100 mm	1820 x 910 x 2100 mm
N.W. / G.W.	330 kgs / 410 kgs	550 kgs / 640 kgs	380 kgs / 460 kgs	600 kgs / 700 kgs	670 kgs / 770 kgs	700 kgs / 800 kgs	780 kgs / 880 kgs

*Specifications are subject to change without prior notice.

BMT 2010FV / BMT 2812FV

BMT 4012FV

- Mechanical Variable Speed / Stationary Table -



*Machine shown with optional accessories

FEATURES:

- ◆ Infinitely variable speed, enlarged speed range
- ◆ Blade welder, grinder & shear
- ◆ Digital blade speed indicator
- ◆ Blade tension indicator
- ◆ Brush for cleaning lower drive wheel
- ◆ Maintenance-free air pump to remove chips
- ◆ Totally enclosed transmission
- ◆ Rip fence
- ◆ Heavy duty cast iron table
- ◆ Magnetic, low voltage controls
- ◆ The upper wheel can be adjusted for band tensioning

MODEL	BMT 2010FV	BMT 2812FV	BMT 4012FV
Cutting Capacity - Throat Depth	500 mm	700 mm	1000 mm
Cutting Capacity - Max. Work Height	320 mm		314 mm
Table Type	Fixed		
Table Size	679 x 736 mm		679 x 736 mm 679 x 477 mm
Table Inclination	L15° / R45° (2 ways)		
Table Work Height	1019 mm	1069 mm	1019 mm
Blade Length	4100 mm	5030 mm	4950 mm
Blade Width	3~25 mm		
Blade Speed	15~1575 mpm		
Bandwheel Size x No.	520 x 44 mm x 2pcs	720 x 44 mm x 2pcs	430 x 44 mm x 4pcs
Blade Welder	25.4 mm Capacity		
Drive Motor	3 HP		4 HP
Machine Size	1295 x 1041 x 2057 mm	1560 x 1041 x 2307 mm	1790 x 1079 x 1905 mm
N.W.	780 kgs	980 kgs	1180 kgs

*Specifications are subject to change without prior notice.

BMT 1408FV / BMT 1408FVE

BMT 1610FV / BMT 1610FVE

- Mechanical Variable Speed / Stationary Table for BMT 1408FV & BMT 1610FV -
- Mechanical Variable Speed / Table Automatic Feed for BMT 1408FVE & BMT 1610FVE -



*Machine shown with optional accessories

FEATURES:

- ◆ Variable speed
- ◆ Blade welder, grinder & shear
- ◆ Blade speed indicator
- ◆ Blade tension indicator
- ◆ Rip fence
- ◆ Chip blower
- ◆ Work light
- ◆ Upper wheel tilt adjuster for BMT 1610FV & BMT 1610FVE

MODEL	BMT 1408FV	BMT 1408FVE	BMT 1610FV	BMT 1610FVE
Cutting Capacity - Throat Depth	356 mm		396 mm	
Cutting Capacity - Max. Work Height	205 mm		255 mm	
Table Size	500 x 500 mm	500 x 600 mm	550 x 600 mm	
Table Inclination	L12° / R15° / F8° / B8°	L5° / R5°	L12° / R15° / F8° / B8°	L5° / R5°
Table Work Height	990 mm		1000 mm	
Table Feed Power	-	80 kgcm / 110V	-	80 kgcm / 110V
Table Stroke	-	330 mm	-	300 mm
Blade Length	2890 mm		3150 mm	
Blade Width	13 mm		16 mm	
Blade Speed	25~100 mpm @ 60 Hz 20~80 mpm @ 50 Hz		Low 25~100 mpm, High 300~1200 mpm @ 60 Hz Low 25~80 mpm, High 250~1000 mpm @ 50 Hz	
Bandwheel Diameter	368 mm		408 mm	
Drive Motor	1 HP		2 HP	
Machine Size	850 x 600 x 1740 mm		940 x 675 x 1840 mm	
N.W.	275 kgs	335 kgs	410 kgs	435 kgs

*Specifications are subject to change without prior notice.

BMT 2012F / BMT 2012HV / BMT 2012HEV

- Mechanical Variable Speed / Stationary Table for BMT 2012F & BMT 2012HV -
- Mechanical Variable Speed / Table Automatic Feed for BMT 2012HEV -



FEATURES:

- ◆ Blade welder, grinder & shear
- ◆ Digital readout tachometer
- ◆ Blade tension indicator
- ◆ Chip blower
- ◆ Work light
- ◆ Upper wheel tilt adjuster
- ◆ Post elevating handwheel
- ◆ Miter protractor for BMT 2012HV & BMT 2012HEV
- ◆ Manual feed screw for BMT 2012HV & BMT 2012HEV
- ◆ Circular cutting attachment for BMT 2012HV & BMT 2012HEV
- ◆ Magnifying glass for BMT 2012HV & BMT 2012HEV
- ◆ Table automatic feed for BMT 2012HEV

*Machine shown with optional accessories

MODEL	BMT 2012F	BMT 2012HV	BMT 2012HEV
Cutting Capacity - Throat Depth	508 mm		
Cutting Capacity - Max. Work Height	305 mm		
Table Size	600 x 560 mm	600 x 700 mm	
Table Inclination	L15° / R15° / F8° / B8°	L10° / R45°	
Table Work Height	1000 mm	1016 mm	
Table Feed Power	-	80 kgcm / 110V	
Table Stroke	-	300 mm	
Blade Length	3970 mm	4035 mm	
Blade Width	27 mm		
Blade Speed	Low 25~180 mpm High 120~1000 mpm	Low 15~125 mpm, High 165~1500 mpm	
Bandwheel Diameter x No.	515 mm x 2		
Welder Capacity	19 mm		
Drive Motor	2 HP	3 HP	
Machine Size	1075 x 765 x 2000 mm	1090 x 810 x 2030 mm	
N.W.	510 kgs	590 kgs	625 kgs

*Specifications are subject to change without prior notice.

BMT 2613FV / BMT 2613FVE

BMT 3612FV / BMT 3612FVE

- Mechanical Variable Speed / Stationary Table for BMT 2613FV & BMT 3612FV -
 - Mechanical Variable Speed / Table Automatic Feed for BMT 2613FVE & BMT 3612FVE -



*Machine shown with optional accessories

FEATURES:

- ◆ Blade welder, grinder & shear
- ◆ Digital readout tachometer
- ◆ Blade tension indicator
- ◆ Chip blower
- ◆ Work light
- ◆ Upper wheel tilt adjuster
- ◆ Post elevating handwheel
- ◆ Miter protractor
- ◆ Manual feed screw
- ◆ Circular cutting attachment
- ◆ Magnifying glass
- ◆ Table automatic feed for BMT 2613FVE & BMT 3612FVE

BMT 40AKV / BMT 50AKV / BMT 60AKV / BMT 100AKV

- Mechanical Variable Speed / Table Automatic Feed -



*Machine shown with optional accessories

FEATURES:

- ◆ Saw blade butt welder with integrated annealing unit
- ◆ Blade shear, grinder
- ◆ Brush for cleaning lower drive wheel
- ◆ Low voltage working lamp
- ◆ Rip fence
- ◆ Miter protractor for angular cutting
- ◆ Groove table

MODEL	BMT 2613FV	BMT 2613FVE	BMT 3612FV	BMT 3612FVE
Cutting Capacity - Throat Depth	658 mm		915 mm	
Cutting Capacity - Max. Work Height	330 mm		305 mm	
Table Size	600 x 700 mm		600 x 700 mm, 450 x 700 mm	
Table Inclination	L10° / R45°			
Table Work Height	1000 mm		1016 mm	
Table Feed Power	-	80 kgcm / 110V	-	80 kgcm / 110V
Table Stroke	-	300 mm	-	300 mm
Blade Length	4680 mm		5020 mm	
Blade Width	27 mm			
Blade Speed	Low 15~125 mpm, High 165~1500 mpm			
Bandwheel Diameter x No.	665 mm x 2		515 mm x 2, 368 mm x 1	
Welder Capacity	19 mm			
Drive Motor	3 HP			
Machine Size	1295 x 810 x 2140 mm		1760 x 810 x 2060 mm	
N.W.	665 kgs	700 kgs	800 kgs	835 kgs

*Specifications are subject to change without prior notice.

MODEL	BMT 40AKV	BMT 50AKV	BMT 60AKV	BMT 100AKV
Cutting Capacity - Throat Depth	410 mm	520 mm	610 mm	1010 mm
Cutting Capacity - Max. Work Height	300 mm	310 mm	340 mm	
Table Size	660 x 700 mm			660 x 700 mm 450 x 500 mm
Table Inclination	L5° / R15° (2 ways)			
Table Stroke	350 mm			
Blade Length	3350 mm	3880 mm	3970 mm	4540 mm
Blade Width	3~20 mm			
Blade Speed	Vari. Speed (mechanical), Low 20~85 mpm / High 120~500 mpm			
Butt Welder Capacity	4.2 KVA, 3~20 mm			
Drive Motor	2 HP			
Hydraulic Motor	1/2 HP			
Packing Size	1350 x 1100 x 2100 mm	1450 x 1100 x 2140 mm	1570 x 1100 x 2140 mm	1920 x 1100 x 2140 mm
N.W. / G.W.	475 kgs / 575 kgs	510 kgs / 600 kgs	555 kgs / 665 kgs	650 kgs / 775 kgs

*Specifications are subject to change without prior notice.

BMT 2010HV

BMT 2812HV

BMT 4012HV

- Mechanical Variable Speed / Hydraulic Table -



*Machine shown with optional accessories

FEATURES:

- ◆ Infinitely variable speed, enlarged speed range
- ◆ Blade welder, grinder & shear
- ◆ Digital blade speed indicator
- ◆ Blade tension indicator
- ◆ Brush for cleaning lower drive wheel
- ◆ Maintenance-free air pump to remove chips
- ◆ Totally enclosed transmission
- ◆ Rip fence
- ◆ Heavy duty cast iron table
- ◆ Magnetic, low voltage controls
- ◆ The upper wheel can be adjusted for band tensioning
- ◆ Motion of work table is controlled by stepless speed controller
- ◆ Work table with auto stopper
- ◆ Work table may take speedy reverse movement

MODEL	BMT 2010HV	BMT 2812HV	BMT 4012HV
Cutting Capacity - Throat Depth	500 mm	700 mm	1000 mm
Cutting Capacity - Max. Work Height	304 mm		
Table Type	Hydraulic		
Table Size	679 x 736 mm		679 x 736 mm 679 x 477 mm
Table Inclination	L15° / R30° (2 ways)		
Table Work Height	1028 mm	1069 mm	1019 mm
Blade Length	4100 mm	5030 mm	4950 mm
Blade Width	3~25 mm		
Blade Speed	15~1575 mpm		
Bandwheel Size x No.	520 x 44 mm x 2pcs	720 x 44 mm 2 pcs	430 x 44 mm x 4 pcs
Blade Welder	25.4 mm Capacity		
Drive Motor	3 HP		4 HP
Machine Size	1295 x 1117 x 2057 mm	1560 x 1117 x 2307 mm	1790 x 1138 x 1905 mm
N.W.	850 kgs	1050 kgs	1250 kgs

*Specifications are subject to change without prior notice.

BMT 360TJD / BMT 400TJD / BMT 450TJD

- Mechanical Variable Speed / Table Automatic Feed -



*Machine shown with optional accessories

FEATURES:

- ◆ Infinitely variable speed
- ◆ The blade tension is cushioned
- ◆ Blade welder & grinder
- ◆ Interchangeable rubber bonded saw wheels
- ◆ Brush for cleaning lower drive wheel
- ◆ Maintenance-free air pump to remove chips
- ◆ Hand wheel controlled speed
- ◆ Adjustable saw blade guides
- ◆ Change speeds while the machine is in operation, without stopping, without pulley changes
- ◆ Cast iron frame to minimize machine vibration
- ◆ Automatic linear cutting
- ◆ Motion of work table is controlled by stepless speed controller
- ◆ Work table with auto stopper
- ◆ Work table may take speedy reverse movement

MODEL	BMT 360TJD	BMT 400TJD	BMT 450TJD
Cutting Capacity - Throat Depth	360 mm	400 mm	450 mm
Cutting Capacity - Max. Work Height	165 mm	215 mm	
Table Size	565 x 500 mm	600 x 560 mm	565 x 500 mm
Table Inclination	L5° / R5° (2 ways)		
Table Stroke	235 mm	260 mm	235 mm
No. of Table T-slot	None	4	None
Blade Length	3025 mm	3300 mm	3570 mm
Blade Width	3~13 mm	3~15 mm	
Blade Speed	25~117 mpm	20~376 mpm	25~117 mpm
Drive Motor	1 HP	2 HP	1 HP
Machine Size	930 x 950 x 1710 mm	1015 x 1040 x 1880 mm	1030 x 950 x 1870 mm
Packing Size	1030 x 700 x 1900 mm	1010 x 910 x 2000 mm	1130 x 700 x 2050 mm
N.W. / G.W.	350 kgs / 430 kgs	580 kgs / 670 kgs	410 kgs / 490 kgs

*Specifications are subject to change without prior notice.

BMT 500TJD / BMT 600TJD / BMT 700TJD / BMT 1000TJD

- Mechanical Variable Speed / Table Automatic Feed -



FEATURES:

- ◆ Infinitely variable speed
- ◆ The blade tension is cushioned
- ◆ Blade welder & grinder
- ◆ Interchangeable rubber bonded saw wheels
- ◆ Brush for cleaning lower drive wheel
- ◆ Maintenance-free air pump to remove chips
- ◆ Hand wheel controlled speed
- ◆ Adjustable saw blade guides
- ◆ Change speeds while the machine is in operation, without stopping, without pulley changes
- ◆ Cast iron frame to minimize machine vibration
- ◆ Automatic linear cutting
- ◆ Motion of work table is controlled by stepless speed controller
- ◆ Work table with auto stopper
- ◆ Work table may take speedy reverse movement

*Machine shown with optional accessories

MODEL	BMT 500TJD	BMT 600TJD	BMT 700TJD	BMT 1000TJD
Cutting Capacity - Throat Depth	510 mm	600 mm	715 mm	1010 mm
Cutting Capacity - Max. Work Height	330 mm	274 mm	325 mm	
Table Size	740 x 680 mm			740 x 680 mm 679 x 477 mm
Table Inclination	L5° / R5° (2 ways)			
Table Stroke	320 mm			
No. of Table T-slot	4			
Blade Length	4070 mm	4376 mm	4090 mm	4670 mm
Blade Width	3~25 mm			
Blade Speed	25~456 mpm		20~394 mpm	
Drive Motor	2 HP			
Machine Size	1210 x 1180 x 2050 mm	1300 x 1170 x 2060 mm	1420 x 1200 x 2040 mm	1690 x 1210 x 2040 mm
Packing Size	1130 x 960 x 2220 mm	1390 x 880 x 2260 mm	1340 x 880 x 2090 mm	1690 x 1030 x 2100 mm
N.W. / G.W.	630 kgs / 730 kgs	700 kgs / 800 kgs	730 kgs / 830 kgs	810 kgs / 910 kgs

*Specifications are subject to change without prior notice.

**BMT 40KC / BMT 50KC / BMT 60KC
BMT 40KS / BMT 50KS / BMT 60KS**

- Inverter Variable Speed / Stationary Table -

**BMT 100KC
BMT 100KS**



*Machine shown with optional accessories



FEATURES:

- ◆ Saw blade butt welder with integrated annealing unit
- ◆ Blade shear, grinder
- ◆ Brush for cleaning lower drive wheel
- ◆ Low voltage working lamp
- ◆ High speed inverter for KS series
- ◆ Optional rip fence
- ◆ Optional miter protractor for angular cutting
- ◆ Optional groove table

MODEL	BMT 40KC BMT 40KS	BMT 50KC BMT 50KS	BMT 60KC BMT 60KS	BMT 100KC BMT 100KS
Cutting Capacity - Throat Depth	410 mm	520 mm	610 mm	1010 mm
Cutting Capacity - Max. Work Height	300 mm	310 mm	340 mm	
Table Size	600 x 500 mm		600 x 500 mm 220 x 500 mm	600 x 500 mm 450 x 500 mm
Table Inclination	15° (4 ways)			
Blade Length	3350 mm	3880 mm	3970 mm	4540 mm
Blade Width	3~16 mm			
Blade Speed	Vari. speed (inverter), Low 20~85 mpm / High 120~500 mpm for BMT KC Series Vari. speed (inverter), Low 18~82 mpm / High 230~1050 mpm for BMT KS Series			
Butt Welder Capacity	2.4 KVA, 3~16 mm			
Drive Motor	2 HP			
Packing Size	1200 x 760 x 2100 mm	1300 x 760 x 2140 mm	1420 x 760 x 2140 mm	1770 x 760 x 2140 mm
N.W. / G.W.	390 kgs / 460 kgs	435 kgs / 510 kgs	470 kgs / 550 kgs	530 kgs / 620 kgs

*Specifications are subject to change without prior notice.

BMT 310V / BMT 360V

BMT 400V / BMT 400VB

- Inverter Variable Speed / Stationary Table -



*Machine shown with optional accessories

FEATURES:

- ◆ Manual blade tension hand wheel and indicator
- ◆ Adjustable work lamp
- ◆ Built-in chip blower
- ◆ Chip tray
- ◆ Blade speed and pitch selector
- ◆ Two speed gear box with variable speed belt drive
- ◆ Adjustable carbide blade guide
- ◆ Large cast iron tilting table
- ◆ Optional blade welder, grinder, shear

MODEL	BMT 310V	BMT 360V	BMT 400V	BMT 400VB
Cutting Capacity - Throat Depth	310 mm	360 mm	400 mm	
Cutting Capacity - Max. Work Height	175 mm	230 mm	300 mm	
Table Size	400 x 500 mm		500 x 540 mm	550 x 600 mm
Table Height	880 mm	890 mm	950 mm	970 mm
Table Inclination	L15° / R45° (2 ways)			
Blade Length	2370~2490 mm	2600~2700 mm	3390~3467 mm	
Blade Width	3~13 mm		3~16 mm	
Blade Speed	18~305 mpm	18~366 mpm	18~503 mpm	
Electric Welder Capacity	1.2 KVA		2.4 KVA	
Drive Motor	1 HP			2 HP
Grinder Motor	1/8 HP			
Machine Size	1530 x 855 x 550 mm	1630 x 590 x 955 mm	1825 x 710 x 1070 mm	
N.W. / G.W.	150 kgs / 170 kgs	173 kgs / 197 kgs	283 kgs / 317 kgs	400 kgs

*Specifications are subject to change without prior notice.

BMT 500V / BMT 700V / BMT 1000V

- Inverter Variable Speed / Stationary Table -



FEATURES:

- ◆ Manual blade tension hand wheel and indicator
- ◆ Adjustable work lamp
- ◆ Built-in chip blower
- ◆ Chip tray
- ◆ Blade speed and pitch selector
- ◆ Two speed gear box with variable speed belt drive
- ◆ Adjustable carbide blade guide
- ◆ Large cast iron tilting table
- ◆ Optional blade welder, grinder, shear

*Machine shown with optional accessories

MODEL	BMT 500V	BMT 700V	BMT 1000V
Cutting Capacity - Throat Depth	500 mm	700 mm	1000 mm
Cutting Capacity - Max. Work Height	320 mm	340 mm	
Table Size	550 x 600 mm	615 x 615 mm 220 x 615 mm	615 x 615 mm 450 x 615 mm
Table Height	980 mm		
Table Inclination	L15° / R45° (2 ways)		
Blade Length	3922~3992 mm	3530~3730 mm	4130~4330 mm
Blade Width	3~19 mm		
Blade Speed	20~976 mpm		
Electric Welder Capacity	4.2 KVA		
Drive Motor	3 HP		
Grinder Motor	1/8 HP		
Machine Size	1960 x 1200 x 740 mm	1960 x 1560 x 905 mm	1960 x 1820 x 905 mm
N.W. / G.W.	346 kgs / 382 kgs	680 kgs	830 kgs

*Specifications are subject to change without prior notice.

BMT 40AKC / BMT 50AKC / BMT 60AKC / BMT 100AKC
BMT 40AKS / BMT 50AKS / BMT 60AKS / BMT 100AKS

- Inverter Variable Speed / Table Automatic Feed -



FEATURES:

- ◆ Saw blade butt welder with integrated annealing unit
- ◆ Blade shear, grinder
- ◆ Brush for cleaning lower drive wheel
- ◆ Low voltage working lamp
- ◆ High speed inverter for KS series
- ◆ Rip fence
- ◆ Miter protractor for angular cutting
- ◆ Groove table

*Machine shown with optional accessories

MODEL	BMT 40AKC BMT 40AKS	BMT 50AKC BMT 50AKS	BMT 60AKC BMT 60AKS	BMT 100AKC BMT 100AKS
Cutting Capacity - Throat Depth	410 mm	520 mm	610 mm	1010 mm
Cutting Capacity - Max. Work Height	300 mm	310 mm	340 mm	
Table Size	660 x 700 mm			660 x 700 mm 450 x 500 mm
Table Inclination	L5° / R15° (2 ways)			
Table Stroke	350 mm			
Blade Length	3350 mm	3880 mm	3970 mm	4540 mm
Blade Width	3~20 mm			
Blade Speed	Vari. speed (inverter), Low 20~85 mpm / High 120~500 mpm for BMT AKC Series Vari. speed (inverter), Low 18~82 mpm / High 230~1050 mpm for BMT AKS Series			
Butt Welder Capacity	4.2 KVA, 3~20 mm			
Drive Motor	2 HP			
Hydraulic Motor	1/2 HP			
Packing Size	1350 x 1100 x 2100 mm	1450 x 1100 x 2140 mm	1570 x 1100 x 2140 mm	1920 x 1100 x 2140 mm
N.W. / G.W.	475 kgs / 575 kgs	510 kgs / 600 kgs	555 kgs / 665 kgs	650 kgs / 775 kgs

*Specifications are subject to change without prior notice.

BMT 0505VH / BMT 0707VH / BMT 0407VS / BMT 0707VS

- Vertical Block & Plate Bandsaw -



*Machine shown with optional accessories

FEATURES:

- ◆ Laser projector
- ◆ Feed roller
- ◆ Automatic chip conveyor
- ◆ Distribution cabinet
- ◆ HMI control panel for BMT 0505VH & BMT 0707VH
- ◆ Hydraulic roller lifting for BMT 0505VH & BMT 0707VH

MODEL	BMT 0505VH	BMT 0707VH	BMT 0407VS	BMT 0707VS
Cutting Capacity - Throat Depth	500 mm	700 mm		
Cutting Capacity - Max. Work Height	500 mm	700 mm	400 mm	700 mm
Support Table Width - Outer	500 mm	700 mm	1670 mm	
Support Table Width - Inner	500 mm	700 mm	730 mm	
Table Work Height	1100 mm	1500 mm		
Blade Size	41 x 1.3 x 4880 mm	54 x 1.6 x 6800 mm	54 x 1.6 x 6200 mm	54 x 1.6 x 6800 mm
Blade Speed	15~80 mpm			
Cutting Length	1.5 m / 2.5 m		4.5 m / 6 m	
Cutting Feed	Hydraulic		Servo 2-2/3 HP + HMI	
Dirve Motor	7.5 HP	10 HP	7.5 HP	10 HP
Hydraulic Motor	2 HP		2 HP x 2	
Coolant Pump	1/4 HP	1/2 HP		
Machine Size	4150 x 1600 x 2460 mm	6350 x 2100 x 3200 mm	12000 x 3750 x 2970 mm	12000 x 3750 x 3270 mm
N.W.	3900 kgs	8500 kgs	15000 kgs	15500 kgs

*Specifications are subject to change without prior notice.

BMT 0510VS / BMT 0710VS / BMT 1013VS

- Vertical Block & Plate Bandsaw -



*Machine shown with optional accessories

FEATURES:

- ◆ Laser projector
- ◆ Feed roller
- ◆ Automatic chip conveyor
- ◆ Distribution cabinet

MODEL	BMT 0510VS	BMT 0710VS	BMT 1013VS
Cutting Capacity - Throat Depth	1000 mm		1370 mm
Cutting Capacity- Max. Work Height	500 mm	700 mm	1070 mm
Support Table Width - Outer	1600 mm		
Support Table Width - Inner	1030 mm		1330 mm
Table Work Height	1600 mm		
Blade Size	54 x 1.6 x 7200 mm	54 x 1.6 x 7600 mm	67 x 1.6 x 8800 mm
Blade Speed	15~80 mpm		
Cutting Length	4.5 m / 6 m		
Cutting Feed	Servo 2-2/3 HP + HMI		
Drive Motor	7.5 HP	10 HP	15 HP
Hydraulic Motor	2 HP x 2		
Coolant Pump	15~80 mpm		
Machine Size	12000 x 4450 x 3150 mm	12000 x 4450 x 3300 mm	12000 x 5000 x 3710 mm
N.W.	21000 kgs	21500 kgs	28000 kgs

*Specifications are subject to change without prior notice.

MEMO

BMT 235SC

- Steel Cutting Circular Saw -



*Machine shown with optional accessories

FEATURES:

- ◆ Built in aluminum and cast iron
- ◆ Small portable for easy carrying
- ◆ Two protectors (one controlling amps, the other controlling temperature of the motor)
- ◆ Anti-reset safety function
- ◆ Start-button inside the operation handle
- ◆ Coolant system

BMT 225FS

- Steel Cutting Circular Saw -



FEATURES:

- ◆ Head rotation 0~45° right to left
- ◆ Gearbox reduction unit with nickel bronz gear and hardened and ground worm screw
- ◆ Coolant pump
- ◆ Hinged pivot
- ◆ Enclosed electric motor with outside ventilation system
- ◆ Optional stand

BMT 250FS / BMT 315FS

- Steel Cutting Circular Saw -



FEATURES:

- ◆ Head rotation 0~45° right to left
- ◆ Gearbox reduction unit with nickel bronz gear and hardened and ground worm screw
- ◆ Coolant pump
- ◆ Hinged pivot
- ◆ Enclosed electric motor with outside ventilation system
- ◆ Stand

*Machine shown with optional accessories

MODEL	BMT 235SC	BMT 225FS
Cutting Capacity (90°)	● 30 mm, ○ 60 mm, ■ 60 x 60 mm	● 30 mm, ○ 65 mm, ■ 65 x 65 mm, ■ 80 x 55 mm
Cutting Capacity (45°)	● 25 mm, ○ 60 mm, ■ 60 x 60 mm	● 25 mm, ○ 60 mm, ■ 60 x 60 mm, ■ 65 x 50 mm
Blade Size	5.0 x 32 x 235 mm	HSS 2.0 x 32 x 225 mm (220T)
Blade Speed	Vari. Speed, 30~80 rpm	52 rpm
Blade Motor	2 HP	1 HP
Vise Opening	-	80 mm
Oil Bath Reduction Gear Box (Ratio)	-	27:1
Coolant Pump	YES	Mechanical Pump
Machine Size	450 x 340 x 850 mm	900 x 380 x 500 mm
N.W.	20 kgs	55 kgs

* Specifications are subject to change without prior notice.

MODEL	BMT 250FS	BMT 315FS
Cutting Capacity (90°)	● 40 mm, ○ 75 mm, ■ 65 x 65 mm, ■ 90 x 50 mm	● 80 mm, ○ 100 mm, ■ 90 x 90 mm, ■ 115 x 70 mm
Cutting Capacity (45°)	● 35 mm, ○ 65 mm, ■ 58 x 58 mm, ■ 70 x 50 mm	● 70 mm, ○ 90 mm, ■ 80 x 80 mm, ■ 85 x 70 mm
Blade Size	HSS 2.0 x 32 x 250 mm (220T)	HSS 2.0 x 32 x 315 mm (220T)
Blade Speed	42 rpm; 42 / 84 rpm (opt.)	42 / 84 rpm
Blade Motor	1.3 HP	2.2 HP
Vise Opening	100 mm	120 mm
Oil Bath Reduction Gear Box (Ratio)	33:1	34:1
Coolant Pump	Mechanical Pump	
Machine Size	900 x 550 x 1360 mm	1100 x 700 x 1560 mm
N.W.	125 kgs	165 kgs

* Specifications are subject to change without prior notice.

BMT 250CS

- Steel Cutting Circular Saw -



FEATURES:

- ◆ Dual miter cutting
- ◆ Coolant system
- ◆ Casting machine base
- ◆ Adjustable work stopper with scale
- ◆ Heavy duty spindle and worm gear box
- ◆ Quick clamping vise
- ◆ Shockproof control panel
- ◆ Stand for BMT 275CS
- ◆ Optional stand for BMT 250CS
- ◆ Optional saw blade

*Machine shown with optional accessories

BMT 275CS

- Steel Cutting Circular Saw -



BMT 315CS / BMT 350CS

- Steel Cutting Circular Saw -



FEATURES:

- ◆ Dual miter cutting
- ◆ Coolant system
- ◆ Casting machine base
- ◆ Adjustable work stopper with scale
- ◆ Heavy duty spindle and worm gear box
- ◆ Quick clamping vise
- ◆ Shockproof control panel
- ◆ Stand
- ◆ Optional saw blade

*Machine shown with optional accessories

MODEL	BMT 250CS	BMT 275CS
Cutting Capacity (90°)	● 30 mm, ○ 75 mm, ■ 65 x 65 mm, ■ 80 x 50 mm	● 40 mm, ○ 85 mm, ■ 75 x 75 mm, ■ 90 x 50 mm
Cutting Capacity (45°)	● 30 mm, ○ 65 mm, ■ 55 x 55 mm, ■ 60 x 50 mm	● 40 mm, ○ 65 mm, ■ 55 x 55 mm, ■ 60 x 50 mm
Blade Size	HSS 2.0 x 32 x 250 mm (120T)	HSS 2.0 x 32 x 275 mm (120T)
Blade Speed	45 / 90 rpm @ 50 Hz 54 / 108 rpm @ 60 Hz	
Blade Motor	1 HP, 2P / 4P	1-1/2 HP, 2P / 4P
Vise Opening	100 mm	
Coolant Pump	1/8 HP, 2 L	1/8 HP, 5 L
Machine Size	880 x 920 x 880 mm (with stand) 880 x 920 x 1600 mm (w/o stand)	970 x 950 x 1645 mm (with stand)
Stand Size	505 x 500 x 720 mm	
N.W.	110 kgs (w/o stand), 21 kgs (stand)	160 kgs (with stand)

* Specifications are subject to change without prior notice.

MODEL	BMT 315CS	BMT 350CS
Cutting Capacity (90°)	● 60 mm, ○ 90 mm, ■ 82 x 82 mm, ■ 110 x 70 mm	● 85 mm, ○ 120 mm, ■ 105 x 105 mm, ■ 160 x 90 mm
Cutting Capacity (45°)	● 50 mm, ○ 90 mm, ■ 75 x 75 mm, ■ 85 x 70 mm	● 75 mm, ○ 100 mm, ■ 80 x 80 mm, ■ 80 x 70 mm
Blade Size	HSS 2.0 x 32 x 315 mm (120T)	HSS 2.0 x 32 x 350 mm (120T)
Blade Speed	44 / 88 rpm @ 50 Hz 52 / 104 rpm @ 60 Hz	24~120 rpm
Blade Motor	2 HP, 2P / 4P, 4P / 8P (opt.)	3 HP / 4 P
Vise Opening	120 mm	170 mm
Coolant Pump	1/8 HP, 5 L	
Machine Size	1010 x 960 x 1770 mm (with stand)	1260 x 1030 x 1820 mm (with stand)
Stand Size	600 x 580 x 720 mm	
N.W.	175 kgs (with stand)	265 kgs (with stand)

* Specifications are subject to change without prior notice.

BMT 355TSC

- Metal Cutting TCT Chop Saw -



*Machine shown with optional accessories

BMT 355ASC

- Abrasive Cut-Off Saw -



*Machine shown with optional accessories

FEATURES:

- ◆ Multi-cutter saw cuts a variety of materials, including ferrous and non-ferrous metals.
- ◆ Built on cast-iron base and vise, aluminum saw arm, steel plate machine stand
- ◆ Specially designed carbide-tipped blade with 80-tooth delivers fast, precise and virtually burn free cuts
- ◆ Adjustable angle cutting from 0 to 45 degree
- ◆ Equipped with quick short range sliding device, quick-lock release vise
- ◆ Cuts 4 times faster than abrasive cut-off saws in 50mm x 50mm x 5mm angle iron
- ◆ Cut steel, stainless steel, thin steel and aluminum with optional blades

FEATURES:

- ◆ Powerful heavy duty cut off saw
- ◆ Built on cast-iron base and vise, aluminum saw arm, steel plate machine stand
- ◆ Cutting steel tubing, pipe, rebar and shaped steel
- ◆ Adjustable angle cutting from 0 to 45 degree
- ◆ Quick lock release vise with max open of 150mm

MODEL	BMT 355TSC	BMT 355ASC
Cutting Capacity (90°)	● 30 mm, ○ 120 mm, ■ 100 x 100 mm, ■ 130 x 100 mm	
Cutting Capacity (45°)	● 25 mm, ○ 100 mm, ■ 90 x 90 mm, ■ 100 x 90 mm	
Blade Size	355 x 25.4 mm	
Blade Speed	45/90 rpm	44/88 rpm
Motor	AC 2 HP	
Machine Size	950 x 480 x 1390 mm	
Packing Size	1000 x 530 x 780 mm	
N.W. / G.W.	120 kgs / 130 kgs	
Container Loads	68 sets / 20'	

* Specifications are subject to change without prior notice.

BMT 75CS

- Abrasive Cut-Off Saw -



*Machine shown with optional accessories

FEATURES:

- ◆ Compact structure, easy to carry
- ◆ Fully-enclosed belt cover
- ◆ Grinding wheel cover with a movable safety cover
- ◆ Unitary motor base, stout and safe construction
- ◆ Induction motor for continuous long time service

BMT 130CS

- Abrasive Cut-Off Saw -



FEATURES:

- ◆ Powerful motor
- ◆ Cast iron frame
- ◆ Heavy fabricated steel guard
- ◆ Secret-type double wheel device for easy carry
- ◆ The chute is design for saw dust
- ◆ Dual drive belt for power and reliability
- ◆ Quick change swivel vise

MODEL	BMT 75CS	BMT 130CS
Cutting Capacity (90°)	● 75 mm, ■ 75 x 75 mm	● 130 mm, ■ 120 x 120 mm
Cutting Capacity (45°)	● 75 mm	● 115 mm, ■ 120 x 120 mm
Blade Size	φ 305 mm	φ 405 mm
Blade Hole	φ 25.4 mm	
No Load Speed	2500 rpm @ 50 Hz 3000 rpm @ 60 Hz	2450 rpm @ 50 Hz 2930 rpm @ 60 Hz
Max. Blade Speed	3120 mpm @ 50 Hz 3750 mpm @ 60 Hz	
Blade Motor	2 HP	3~5 HP
Packing Size	790 x 760 x 570 mm / 2sets	850 x 480 x 640 mm
N.W. / G.W.	110 kgs / 140 kgs / 2sets	95 kgs / 100 kgs

* Specifications are subject to change without prior notice.

BMT 130CSR

- Abrasive Cut-Off Saw -



*Machine shown with optional accessories

FEATURES:

- ◆ Powerful motor
- ◆ Cast iron frame
- ◆ Heavy fabricated steel guard
- ◆ The chute is design for saw dust
- ◆ Dual drive belt for power and reliability
- ◆ Quick change swivel base

BMT 150CS

- Abrasive Cut-Off Saw -



FEATURES:

- ◆ Compact structure, easy to carry
- ◆ Fully-enclosed belt cover
- ◆ Grinding wheel cover with a movable safety cover
- ◆ Unitary motor base, stout and safe construction
- ◆ Induction motor for continuous long time service

BMT 350ALU

- Aluminum Circular Saw -



*Machine shown with optional accessories

BMT 400ALU



MODEL	BMT 130CSR	BMT 150CS
Cutting Capacity (90°)	● 130 mm, ■ 120 x 120 mm	● 150 mm, ■ 140 x 140 mm
Cutting Capacity (45°)	● 115 mm, ■ 90 x 90 mm	● 135 mm
Blade Size	φ 405 mm	φ 508 mm
Blade Hole	φ 25.4 mm	
No Load Speed	2450 rpm @ 50 Hz 2930 rpm @ 60 Hz	2000 rpm @ 50 Hz 2400 rpm @ 60 Hz
Max. Blade Speed	3120 mpm @ 50 Hz 3750 mpm @ 60 Hz	
Blade Motor	3~5 HP	7.5 HP
Packing Size	810 x 670 x 730 mm	1000 x 1090 x 710 mm / 2sets
N.W. / G.W.	114 kgs / 120 kgs	320 kgs / 350 kgs / 2 sets

* Specifications are subject to change without prior notice.

MODEL	BMT 350ALU	BMT 400ALU
Cutting Capacity (90°)	● 100 mm, ■ 100 x 100 mm, ■ 100 x 195 mm	● 110 mm, ■ 100 x 160 mm, ■ 60 x 200 mm
Cutting Capacity (45°)	● 100 mm, ■ 100 x 100 mm, ■ 100 x 135 mm	● 100 mm, ■ 100 x 100 mm, ■ 60 x 140 mm
Cutting Capacity (60°)	● 100 mm, ■ 100 x 100 mm, ■ 100 x 135 mm	● 100 mm, ■ 100 x 100 mm, ■ 60 x 140 mm
Blade Size	350 x 30 mm	400 x 30 mm
Blade Speed	2800 rpm	
Blade Motor	2 HP	
Coolant System	Yes	
Machine Size	700 x 700 x 1400 mm	640 x 780 x 1250 mm
Packing Size	660 x 900 x 1500 mm	600 x 800 x 1400 mm
N.W. / G.W.	90 kgs / 100 kgs	120 kgs / 145 kgs

* Specifications are subject to change without prior notice.

BMT 16CE / BMT 18CE

- Aluminum Circular Saw -



FEATURES:

- ◆ Single head cutting off machine with semi-automatic raising blade and adjustable lifting speed
- ◆ For all aluminum profile & plastic
- ◆ Possibility to perform trimming operation
- ◆ Two vertical pneumatic clamping sets
- ◆ Two horizontal pneumatic clamping sets
- ◆ Full protection blade guard (without blade)
- ◆ Trimming fence
- ◆ Auto mist lubrication fluid nozzle to reduce blade from overheating
- ◆ Emergency stop switch for safety operation

*Machine shown with optional accessories

MODEL	BMT 16CE	BMT 18CE
Cutting Angle	± 45°	
Blade Diameter	400 mm	450 mm
Blade Speed	2800 rpm	3000 rpm
Blade Motor	2 HP	
Table Size	400 x 400 mm	φ 500 mm
Table Height	410 mm	890 mm
Machine Size	490 x 790 x 1300 mm	720 x 1000 x 1300 mm
Packing Size	860 x 560 x 1130 mm	1000 x 805 x 1360 mm
N.W. / G.W.	107 kgs / 126 kgs	243 kgs / 255 kgs

* Specifications are subject to change without prior notice.

BMT 18CA

- Circular Sawing Machine -



*Machine shown with optional accessories

FEATURES:

- ◆ To operate the machine, simply treadle on the foot switch, the machine will automatically perform clamping and cutting for convenient operation.
- ◆ Concealed saw blade performs upward cutting.
- ◆ Single or multiple workpieces can be cut simultaneously.
- ◆ While cutting, the oil mist splashes automatically for cooling and lubrication.
- ◆ Cutting feed is driven by an air/hydraulic combination cylinder for extremely stable cutting speed.

MODEL	BMT 18CA	BMT 18CC
Cutting Angle	90° or 45°	
Cutting Capacity	115 x 115 mm, 100 x 220 mm, 60 x 270 mm, 20 x 300 mm	
Blade Diameter x Hole	457 x 25.4 mm	
Blade Speed	3200 rpm	
Blade Motor	5 HP, 7.5 / 10 HP (opt.)	
Table Area	640 x 380 mm	
Table Height	860 mm	
Air Pressure	4~6 kgs/cm ²	
Conveyor Length (opt.)	1~7 m	
Machine Size	840 x 800 x 1250 mm	
Packing Size	960 x 920 x 1450 mm	
N.W. / G.W.	300 kgs / 380 kgs	330 kgs / 410 kgs

* Specifications are subject to change without prior notice.

BMT 18CC



CUTTING MATERIALS:

- ◆ Aluminum
- ◆ Brass
- ◆ Heat sink
- ◆ PVC
- ◆ Plastic steel
- ◆ Bakelite
- ◆ Acrylic plastic
- ◆ Teflon
- ◆ Honeycomb board
- ◆ Wood
- ◆ Other non-ferrous metals

OPTIONAL ACCESSORIES:

- ◆ Infeed and outfeed roller table
- ◆ Chip collector
- ◆ Horizontal clamp
- ◆ Hydraulic feeding
- ◆ Automatic positioning
- ◆ Automatic feeding
- ◆ Automatic cutting
- ◆ Sawblade

BMT 18CD

- Circular Sawing Machine -



BMT 18CP

*Machine shown with optional accessories



FEATURES:

- ◆ To operate the machine, simply treadle on the foot switch, the machine will automatically perform clamping and cutting for convenient operation.
- ◆ Concealed saw blade performs upward cutting.
- ◆ Single or multiple workpieces can be cut simultaneously.
- ◆ While cutting, the oil mist splashes automatically for cooling and lubrication.
- ◆ Cutting feed is driven by an air/hydraulic combination cylinder for extremely stable cutting speed.

MODEL	BMT 18CD	BMT 18CP
Cutting Angle	90° or 45°	
Cutting Capacity	125 x 125 mm, 100 x 230 mm, 60 x 270 mm, 60 x 300 mm	110 x 110 mm, 100 x 180 mm, 60 x 230 mm, 20 x 240 mm
Blade Diameter x Hole	457 x 25.4 mm	
Blade Speed	3200 rpm	
Blade Motor	7.5 HP, 10 HP (opt.)	
Table Area	640 x 380 mm	1350 x 380 mm
Table Height	860 mm	875 mm
Air Pressure	4~6 kgs/cm ²	
Conveyor Length (opt.)	1~7 m	
Machine Size	840 x 870 x 1660 mm	1500 x 840 x 1460 mm
Packing Size	960 x 990 x 1860 mm	1620 x 980 x 1660 mm
N.W. / G.W.	360 kgs / 440 kgs	600 kgs / 750 kgs

* Specifications are subject to change without prior notice.

CUTTING MATERIALS:

- ◆ Aluminum
- ◆ Brass
- ◆ Heat sink
- ◆ PVC
- ◆ Plastic steel
- ◆ Bakelite
- ◆ Acrylic plastic
- ◆ Teflon
- ◆ Honeycomb board
- ◆ Wood
- ◆ Other non-ferrous metals

OPTIONAL ACCESSORIES:

- ◆ Infeed and outfeed roller table
- ◆ Chip collector
- ◆ Horizontal clamp
- ◆ Hydraulic feeding
- ◆ Automatic positioning
- ◆ Automatic feeding
- ◆ Automatic cutting
- ◆ Sawblade

BMT 20 / BMT 2024

- Circular Sawing Machine -

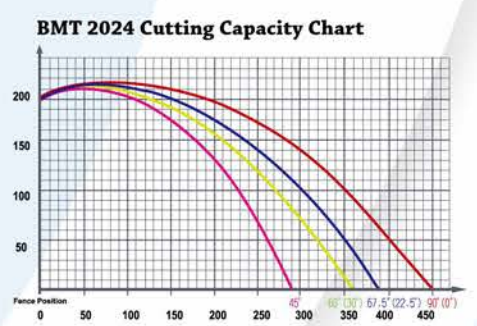
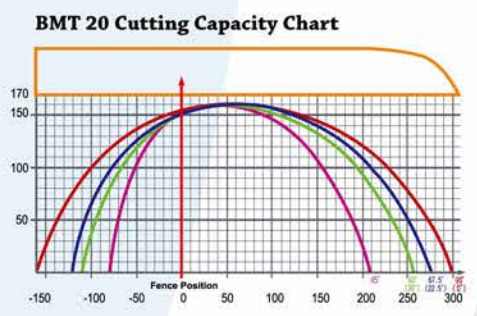
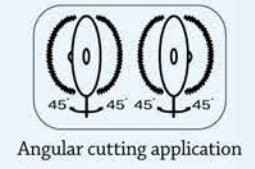

*Machine shown with optional accessories

FEATURES:

- ◆ To operate the machine, simply treadle on the foot switch, the machine will automatically perform clamping and cutting for convenient operation.
- ◆ Concealed saw blade performs upward cutting.
- ◆ Single or multiple workpieces can be cut simultaneously.
- ◆ While cutting, the oil mist splashes automatically for cooling and lubrication.
- ◆ Cutting feed is driven by an air/hydraulic combination cylinder for stable cutting speed.

MODEL	BMT 20	BMT 2024
Cutting Angle	45° ~ 0° ~ -45°	
Cutting Capacity	See Cutting Capacity Chart	
Blade Diameter x Hole	508 x 25.4 mm	610 x 25.4 mm
Blade Speed	2800 rpm	1800 rpm
Blade Motor	7.5 HP	
Table Area	920 x 650 mm	1140 x 750 mm
Table Height	875 mm	920 mm
Air Pressure	4~6 kgs/cm ²	
Machine Size	1200 x 1090 x 1780 mm	1480 x 1350 x 2100 mm
Packing Size	1320 x 1210 x 1980 mm	1600 x 1470 x 2260 mm
N.W. / G.W.	500 kgs / 610 kgs	800 kgs / 920 kgs

* Specifications are subject to change without prior notice.

CUTTING MATERIALS:

- ◆ Aluminum
- ◆ Brass
- ◆ Heat sink
- ◆ PVC
- ◆ Plastic steel
- ◆ Bakelite
- ◆ Acrylic plastic
- ◆ Teflon
- ◆ Honeycomb board
- ◆ Wood
- ◆ Other non-ferrous metals

OPTIONAL ACCESSORIES:

- ◆ Infeed and outfeed roller table
- ◆ Chip collector
- ◆ Horizontal clamp
- ◆ Hydraulic feeding
- ◆ Automatic positioning
- ◆ Automatic feeding
- ◆ Automatic cutting
- ◆ Sawblade

BMT 2030 / BMT 2036

- Circular Sawing Machine -

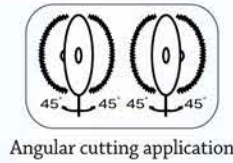

Angular cutting application

*Machine shown with optional accessories

BMT 2030 Cutting Capacity Chart

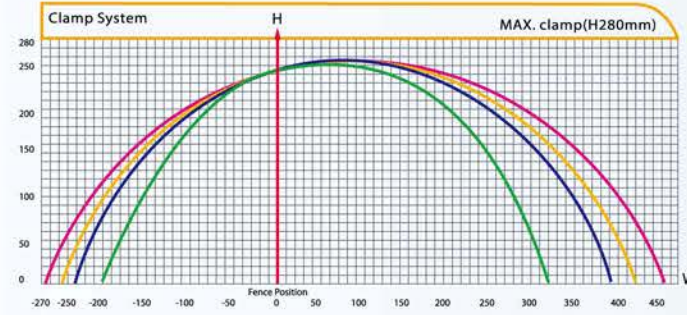

BMT 2036 Cutting Capacity Chart

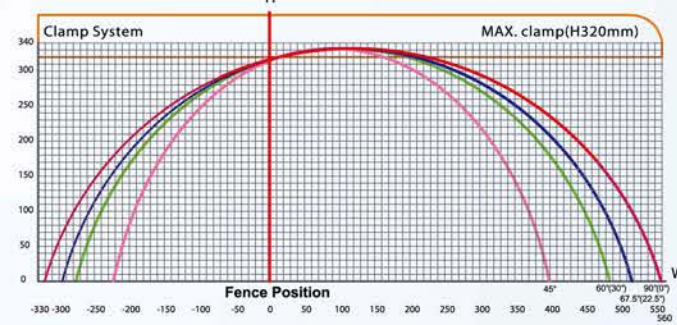

FEATURES:

- ◆ To operate the machine, simply treadle on the foot switch, the machine will automatically perform clamping and cutting for convenient operation.
- ◆ Concealed saw blade performs upward cutting.
- ◆ Single or multiple workpieces can be cut simultaneously.
- ◆ While cutting, the oil mist splashes automatically for cooling and lubrication.
- ◆ Cutting feed is driven by an air/hydraulic combination cylinder for stable cutting speed.

CUTTING MATERIALS:

- ◆ Aluminum
- ◆ Brass
- ◆ Heat sink
- ◆ PVC
- ◆ Plastic steel
- ◆ Bakelite
- ◆ Acrylic plastic
- ◆ Teflon
- ◆ Honeycomb board
- ◆ Wood
- ◆ Other non-ferrous metals

OPTIONAL ACCESSORIES:

- ◆ Infeed and outfeed roller table
- ◆ Chip collector
- ◆ Horizontal clamp
- ◆ Hydraulic feeding
- ◆ Automatic positioning
- ◆ Automatic feeding
- ◆ Automatic cutting
- ◆ Sawblade

MODEL	BMT 2030	BMT 2036
Cutting Angle	45° ~ 0° ~ -45°	
Cutting Capacity	See Cutting Capacity Chart	
Blade Diameter x Hole	762 x 50 mm	914 x 50 mm
Blade Speed	1170 rpm @ 60 Hz 1185 rpm @ 50 Hz	936 rpm @ 60 Hz 862 rpm @ 50 Hz
Blade Motor	10 HP	
Table Area	1327 x 640 mm	1500 x 770 mm
Table Height	1070 mm	1220 mm
Air Pressure	4~6 kgs/cm ²	
Machine Size	1660 x 1400 x 2210 mm	1770 x 1580 x 2520 mm
Packing Size	1780 x 1520 x 2300 mm	1900 x 1700 x 2230 mm
N.W. / G.W.	1300 kgs / 1500 kgs	1800 kgs / 2300 kgs

* Specifications are subject to change without prior notice.

BMT 24D

- Circular Sawing Machine -



*Machine shown with optional accessories

BMT 24C / BMT 20L

- Circular Sawing Machine -



FEATURES:

- ◆ To operate the machine, simply treadle on the foot switch, the machine will automatically perform clamping and cutting for convenient operation.
- ◆ Concealed saw blade performs upward cutting.
- ◆ Single or multiple workpieces can be cut simultaneously.
- ◆ While cutting, the oil mist splashes automatically for cooling and lubrication.
- ◆ Cutting feed is driven by an air/hydraulic combination cylinder for stable cutting speed.

MODEL	BMT 24D	BMT 24C	BMT 20L
Cutting Angle	90° or 45°		90°
Cutting Capacity	190 x 190 mm, 150 x 340 mm, 80 x 400 mm, 20 x 450 mm		140 x 300 mm, 80 x 400 mm
Blade Diameter x Hole	610 x 25.4 mm		356/406/457/508 mm x 25.4 mm
Blade Speed	1800 rpm		2800 rpm
Blade Motor	10 HP		7.5 HP
Table Area	660 x 700 mm		560 x 700 mm
Table Height	830 mm		825 mm
Air Pressure	4~6 kgs/cm ²		
Conveyor Length (opt.)	1~7 m		
Machine Size	860 x 1310 x 1850 mm	860 x 1310 x 1460 mm	1480 x 900 x 1530 mm
Packing Size	980 x 1430 x 2050 mm	980 x 1430 x 1660 mm	1600 x 1020 x 1730 mm
N.W. / G.W.	550 kgs / 650 kgs	480 kgs / 580 kgs	680 kgs / 780 kgs

* Specifications are subject to change without prior notice.

CUTTING MATERIALS:

- ◆ Aluminum
- ◆ Brass
- ◆ Heat sink
- ◆ PVC
- ◆ Plastic steel
- ◆ Bakelite
- ◆ Acrylic plastic
- ◆ Teflon
- ◆ Honeycomb board
- ◆ Wood
- ◆ Other non-ferrous metals

OPTIONAL ACCESSORIES:

- ◆ Hydraulic feeding
- ◆ Worktable retract system

BMT 24L / BMT 30D

- Circular Sawing Machine -



*Machine shown with optional accessories

FEATURES:

- ◆ To operate the machine, simply treadle on the foot switch, the machine will automatically perform clamping and cutting for convenient operation.
- ◆ Concealed saw blade performs upward cutting.
- ◆ Single or multiple workpieces can be cut simultaneously.
- ◆ While cutting, the oil mist splashes automatically for cooling and lubrication.
- ◆ Cutting feed is driven by an air/hydraulic combination cylinder for stable cutting speed.

MODEL	BMT 24L	BMT 30D
Cutting Angle	90°	
Cutting Capacity	50 x 700 mm, 100 x 650 mm, 190 x 480 mm	240 x 240 mm, 200 x 400 mm, 150 x 530 mm, 100 x 570 mm, 50 x 580 mm
Blade Diameter x Hole	610 x 25.4 mm	762 x 50 mm
Blade Speed	1800 rpm	1185 rpm
Blade Motor	15 HP	20 HP
Table Area	660 x 850 mm	810 x 730 mm
Table Height	850 mm	887 mm
Air Pressure	4~6 kgs/cm ²	
Conveyor Length (opt.)	1~7 m	
Machine Size	1230 x 2120 x 1618 mm	1386 x 1520 x 2065 mm
Packing Size	1350 x 2240 x 1880 mm	1500 x 1620 x 2100 mm
N.W. / G.W.	750 kgs / 880 kgs	1160 kgs / 1300 kgs

* Specifications are subject to change without prior notice.

CUTTING MATERIALS:

- ◆ Aluminum
- ◆ Brass
- ◆ Heat sink
- ◆ PVC
- ◆ Plastic steel
- ◆ Bakelite
- ◆ Acrylic plastic
- ◆ Teflon
- ◆ Honeycomb board
- ◆ Wood
- ◆ Other non-ferrous metals

OPTIONAL ACCESSORIES:

- ◆ Hydraulic feeding
- ◆ Worktable retract system

BMT 75AC / BMT 100AC

- Circular Sawing Machine -



*Machine shown with optional accessories

FEATURES:

- ◆ Touch screen NC control
- ◆ Servo motor and ball screw for cutting
- ◆ High efficiency reducer
- ◆ Servo motor feed
- ◆ Powder brake
- ◆ 10 different length sets
- ◆ Hydraulic clamped horizontal & vertical vises
- ◆ Air oil mist spray
- ◆ Automatic chip conveyor
- ◆ Out of stock detector
- ◆ Auto loading table
- ◆ Inverter drive
- ◆ Work light

MODEL	BMT 75AC	BMT 100AC
Cutting Capacity	● 10~75 mm, ■ 10~60 mm	● 20~100 mm, ■ 20~80 mm
Length of Cutting Rest	20+ Cutting Length	25+ Cutting Length
Feeding Length Per Time	700 mm	
Blade Size	32 x 2 x 285 mm	50 x 2.6 x 360 mm
Blade Speed	18~185 rpm	16~160 rpm
Blade Motor	10 HP	15 HP
Hydraulic Motor	2 HP	
Cutting Motor	4 HP	
Feed Motor	1 HP	
Driving Pressure	50 kgs/cm ² (5 Mpa)	
Air Pressure	4~6 kgs/cm ²	
Machine Size	1700 x 2200 x 1700 mm	2200 x 2200 x 1900 mm
Machine + Rack Size	6520 x 2200 x 1700 mm	7000 x 2200 x 1900 mm
N.W.	3350 kgs	3850 kgs

* Specifications are subject to change without prior notice.

BMT 75WSC / BMT 100WSC

- High Speed Circular Sawing Machine -



*Machine shown with optional accessories

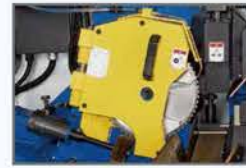

Backlashless Gear Head



Smart HMI Control Panel



Servo feeding with hydraulic floating saddle and vertical press

FEATURES:

- ◆ Special designed backlashless gear head
- ◆ Hydraulic powerful chip brush for longer cutting result
- ◆ Servo feeding with hydraulic floating saddle and vertical press
- ◆ Scraper type automatic chip conveyor and mist cooling system
- ◆ Material separation system that separate from count trim, excess material and normal material
- ◆ Smart HMI control panel
- ◆ Feeding loader for materials stock and automatic material detection
- ◆ Optional bundle loader with material alignment
- ◆ Optional mist filter to remove contaminants of dust and oil mist

MODEL	BMT 75WSC	BMT 100WSC
Cutting Capacity	● 8~75 mm, ■ 8 x 8~60 x 60 mm	● 10~102 mm, ■ 10 x 10~85 x 85 mm
Blade Motor	15 HP	
Hydraulic Pump Motor	2 HP	
Blade Speed	Vari. speed (inverter), 50~200 rpm	
Blade Size	285 mm	360 mm
Blade Feed	Servo motor & Ball screw	
Feeding Length	Single	0~600 mm
	Multiple	600~6000 mm
Machine Size	2620 x 6840 x 2190 mm	2820 x 6920 x 2230 mm
Machine Weight With Table	3250 kgs	3600 kgs

* Specifications are subject to change without prior notice.

BMT 24NCL / BMT 30NCL

- NC Circular Sawing Machine -



*Machine shown with optional accessories

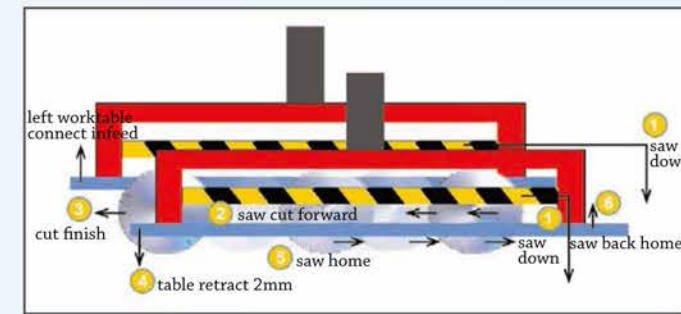

SAWBLADE FEED WAY DIAGRAM

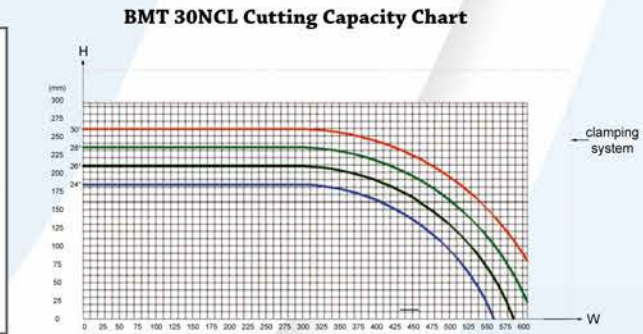
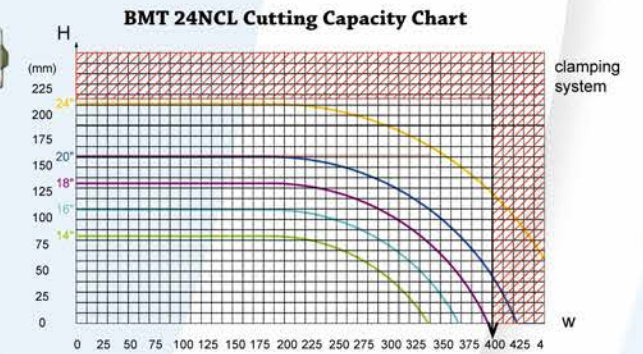

MODEL	BMT 24NCL	BMT 30NCL
Drive System	Ball screw (or High Precision Gear Rack)	
Cutting Capacity	200 x 200 mm, 175 x 210 mm, 130 x 350 mm, 40 x 400 mm (Cutting Capacity Chart)	250 x 250 mm, 210 x 400 mm, 180 x 500 mm (Cutting Capacity Chart)
Max. Feed Distance (One cycle)	1250 mm, 2500 / 6000 mm (opt.) Unlimited Recycle Feed Distance	
Automatic Feed Accuracy	± 0.1 mm	Less than 150 x 300 mm: ±0.1 mm Bigger than 150 x 300 mm: ±0.15 mm
Table Height	900 mm	1010 mm
Blade Diameter x Hole	305~610 x 25.4 mm	610~762 x 25.4 mm
Blade Speed	1500~3500 rpm	1000~3000 rpm
Blade Motor	15 HP	
Inverter Motor	15 HP	20 HP
Hydraulic Motor	2 HP	1 HP (opt.)
Servo Motor	1-1/3 HP, 2 HP (opt.)	2-2/3 HP
Touch-Sensing Screen	7"	
Air Pressure	4~6 kgs / cm ²	
Max. Load	100 kgs	200 kgs
Machine Size	3500 x 2100 x 1860 mm	3900 x 2290 x 1940 mm
Packing Size	3620 x 2220 x 2000 mm	4120 x 2390 x 2140 mm
N.W. / G.W.	2300 kgs / 2700 kgs	2800 kgs / 3100 kgs

* Specifications are subject to change without prior notice.

FEATURES:

- ◆ Automatic feed, positioning, oil spraying and sawing
- ◆ Horizontal cutting
- ◆ Touch screen
- ◆ Self-diagnostic function
- ◆ Hydraulic feed system
- ◆ Two sets of each vertical & horizontal clamps
- ◆ 100 sets of size memory capacity
- ◆ Automatically record required time & quantity
- ◆ Detection for lack of material
- ◆ Feed models: stepping feed, repeat cycle feed, manual feed

OPTIONAL ACCESSORIES:

- ◆ Infeed and outfeed roller table
- ◆ Chip collector
- ◆ Hydraulic clamping
- ◆ Sawblade

BMT 455A

- Automatic Circular Sawing Machine -



*Machine shown with optional accessories

BMT 610A / BMT 910A

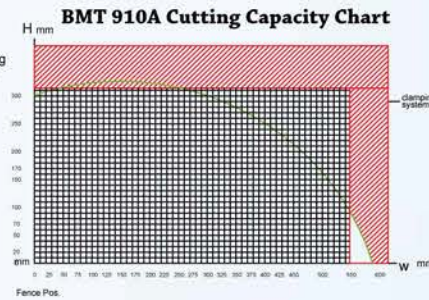
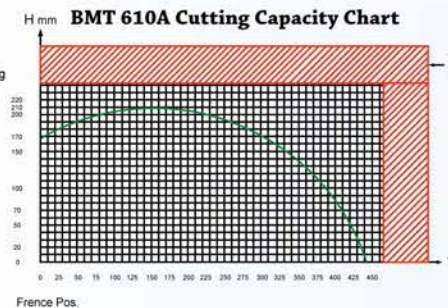
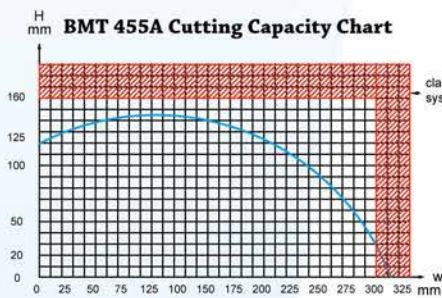

MODEL	BMT 455A	BMT 610A	BMT 910A
Drive System	Ball screw (Servo Motor Drive)		
Cutting Capacity	120 x 120 mm, 100 x 200 mm, 20 x 280 mm (Cutting Capacity Chart)	190 x 190 mm, 50 x 320 mm, 40 x 420 mm (Cutting Capacity Chart)	300 x 300 mm, 200 x 460 mm, 80 x 550 mm (Cutting Capacity Chart)
Max. Feed Distance (One cycle)	500 mm, Unlimited Recycle Feed Distance		
Automatic Feed Accuracy	± 0.1 mm	± 0.15 mm	± 0.2 mm
Table Height	-	921 mm	1339 mm
Blade Diameter x Hole	457 x 25.4 mm	610 x 25.4 mm	914 x 50 mm
Blade Speed	3200 rpm	1800 rpm	900 rpm
Blade Motor	10 HP		20 HP
Hydraulic Feed Motor	1 HP		
Servo Motor	1-1/3 HP		
Max. Load	100 kgs		
Touch-Sensing Screen	5.7"	7"	
Air Pressure	4~6 kgs/cm ²		
Machine Size	2500 x 1000 x 1850 mm	2500 x 1300 x 2020 mm	2910 x 1953 x 2360 mm
Packing Size	2620 x 1120 x 2050 mm	2620 x 1420 x 2220 mm	3010 x 2050 x 2250 mm
N.W. / G.W.	1400 kgs / 1750 kgs	1600 kgs / 2000 kgs	3480 kgs

FEATURES:

- ◆ Automatic feed, positioning, oil spraying and sawing
- ◆ Horizontal cutting
- ◆ Touch screen
- ◆ Self-diagnostic function
- ◆ Hydraulic feed system
- ◆ Two sets of each vertical & horizontal clamps
- ◆ 100 sets of size memory capacity
- ◆ Automatically record required time & quantity
- ◆ Detection for lack of material
- ◆ Feed models: stepping feed, repeat cycle feed, manual feed

OPTIONAL ACCESSORIES:

- ◆ Infeed and outfeed roller table
- ◆ Chip collector
- ◆ Sawblade

* Specifications are subject to change without prior notice.

BMT 18DB / BMT 24DB

- Automatic Circular Sawing Machine -



*Machine shown with optional accessories

MODEL	BMT 18DB	BMT 24DB
Drive System	Ball screw (Servo Motor Drive)	
Cutting Capacity	125 x 125 mm, 100 x 200 mm, 20 x 280 mm (Cutting Capacity Chart)	160 x 300 mm, 40 x 420 mm (Cutting Capacity Chart)
Max. Feed Distance (One cycle)	350 mm Unlimited Recycle Feed Distance	
Automatic Feed Accuracy	± 0.1 mm	± 0.15 mm
Table Height	870 mm	830 mm
Blade Diameter x Hole	457 x 25.4 mm	610 x 25.4 mm
Blade Speed	3200 rpm	1800 rpm
Blade Motor	7.5 HP, 10 HP (opt.)	10 HP
Hydraulic Feed Motor	1 HP (opt.)	1 HP
Servo Motor	1-1/3 HP	
Max. Load	100 kgs	
Touch-Sensing Screen	7"	
Air Pressure	4~6 kgs/cm ²	
Machine Size	1300 x 870 x 1800 mm	1675 x 1337 x 1863 mm
Packing Size	1420 x 900 x 2000 mm	1775 x 1437 x 2063 mm
N.W. / G.W.	550 kgs / 650 kgs	1665 kgs

FEATURES:

- ◆ Automatic feed, positioning, oil spraying and sawing
- ◆ Horizontal cutting
- ◆ Touch screen
- ◆ Self-diagnostic function
- ◆ Hydraulic feed system
- ◆ Two sets of each vertical & horizontal clamps
- ◆ 100 sets of size memory capacity
- ◆ Automatically record required time & quantity
- ◆ Detection for lack of material
- ◆ Feed models: stepping feed, repeat cycle feed, manual feed

OPTIONAL ACCESSORIES:

- ◆ Infeed and outfeed roller table
- ◆ Chip collector
- ◆ Sawblade

* Specifications are subject to change without prior notice.

BMT 14A / BMT 14B

- Double Blade Angular Sawing Machine -

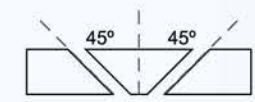

Cutting method: rocking arm drive
Optional cutting: choice of individual right or left cutting (to avoid material kicking)

FEATURES:

- ◆ To operate the machine, simply treadle on the foot switch, the machine will automatically perform clamping and cutting for convenient operation.
- ◆ Concealed saw blade performs upward cutting.
- ◆ Single or multiple workpieces can be cut simultaneously.
- ◆ While cutting, the oil mist splashes automatically for cooling and lubrication.
- ◆ Cutting feed is driven by an air/hydraulic combination cylinder for stable cutting speed.

*Machine shown with optional accessories

MODEL	BMT 14A	BMT 14B
Cutting Angle	45°	
Cutting Capacity	100 x 100 mm, 140 x 90 mm	150 x 130 mm, 180 x 100 mm, 250 x 70 mm
Table Size	870 x 260 mm	870 x 290 mm
Table Height	830 mm	800 mm
Blade Diameter x Hole	356 x 25.4 mm x 2pcs	457 x 25.4 mm x 2pcs
Blade Speed	3400 rpm	3000 rpm
Blade Motor	2 HP x 2	
Clamping Way	3 (Vertical & Horizontal Clamps)	
Infeed / Outfeed Conveyor Length	2400 mm	
Air Pressure	4~6 kgs/cm ²	
Machine Size	1370 x 820 x 1310 mm	1520 x 930 x 1440 mm
Packing Size	1490 x 950 x 1510 mm	1640 x 1050 x 1640 mm
N.W. / G.W.	310 kgs / 410 kgs	500 kgs / 610 kgs

OPTIONAL ACCESSORIES:

- ◆ Infeed and outfeed roller table
- ◆ Automatic positioning
- ◆ Automatic feeding
- ◆ Automatic cutting
- ◆ Sawblade

* Specifications are subject to change without prior notice.

BMT 350L

- Double Blade Angular Sawing Machine -



*Machine shown with optional accessories

MODEL	BMT 350L
Cutting Angle	45°
Cutting Capacity	350 x 70 mm, 400 x 90 mm (opt.)
Table Size	500 x 320 mm
Table Height	840 mm
Blade Diameter x Hole	356 x 25.4 mm x 2pcs
Blade Speed	3200 rpm
Blade Motor	2 HP x 2
Clamping Way	Vertical Clamps x 2pcs
Conveyor Length	2400 mm
Air Pressure	4~6 kgs/cm ²
Machine Size	1930 x 725 x 1300 mm
Packing Size	2050 x 845 x 1500 mm
N.W. / G.W.	650 kgs / 780 kgs

* Specifications are subject to change without prior notice.

BMT 180HS



* Machine shown with optional accessories

BMT 200HS / BMT 203HS



**BMT 200KP / BMT 225KP / BMT 280KP / BMT 320KP
BMT 380KP / BMT 450KP**

- Hydraulic Power Hacksaw -



* Machine shown with optional accessories

FEATURES:

- ◆ Complete hydraulic system
- ◆ Infinitely variable saw feed pressure control
- ◆ Complete electric components with motor protection
- ◆ Recirculating coolant system
- ◆ Adjustable material length stop
- ◆ Clamping device for short ends
- ◆ Equalizing bar for jaws
- ◆ Material support stands
- ◆ Sawblade
- ◆ Grease gun

MODEL	BMT 180HS	BMT 200HS	BMT 203HS
Cutting Capacity (90°)	● 180 mm, ■ 180 x 140 mm	● 203 mm, ■ 203 x 150 mm	
Cutting Capacity (45°)	● 100 mm, ■ 100 x 140 mm	● 90 mm, ■ 100 x 150 mm	● 100 mm, ■ 190 x 150 mm
Blade Size	400 x 25 x 1.25 mm	400 x 32 x 1.6 mm	450 x 32 x 1.6 mm
Blade Motor	1/3 HP		
Stroke/Minute	2 steps, 60 / 80 mm/min		
Stroke	90 x 150 mm	130 x 190 mm	130 x 240 mm
Coolant Tank	2 L		
Machine Size	875 x 330 x 650 mm	950 x 345 x 730 mm	
Packing Size	940 x 440 x 730 mm	1040 x 440 x 800 mm	
N.W. / G.W.	77 kgs / 88 kgs	120 kgs / 130 kgs	

*Specifications are subject to change without prior notice.

MODEL	BMT 200KP	BMT 225KP	BMT 280KP	BMT 320KP	BMT 380KP	BMT 450KP
Cutting Capacity	● 200 mm, ■ 190 x 190 mm	● 225 mm, ■ 225 x 220 mm	● 280 mm, ■ 280 x 250 mm	● 320 mm, ■ 300 x 300 mm	● 380 mm, ■ 330 x 350 mm	● 450 mm, ■ 380 x 430 mm
Max. Cutting Angle	45° / 90°	45° / 120°	45° / 140°	45° / 185°		45° / 250°
Blade Size	350 x 32 x 1.6 x 8.3 mm	400 x 32 x 1.6 x 8.3 mm	450 x 32 x 1.6 x 8.3 mm	500 x 82 x 2 x 10.3 mm	550 x 45 x 2.25 x 10.3 mm	650 x 50 x 2.5 x 12.3 mm
Blade Motor	1 HP			2 HP		3 HP
Stroke / Minute	2 steps, 105/125 mm/min	3 steps, 80 / 100 / 120 mm/min				
Stroke	118 mm			138 mm		155 mm
Packing Size	1240 x 730 x 1010 mm	1420 x 850 x 1100 mm		1550 x 850 x 1200 mm		1970 x 940 x 1400 mm
N.W. / G.W.	270 kgs / 330 kgs	415 kgs / 475 kgs	430 kgs / 490 kgs	450 kgs / 520 kgs	475 kgs / 545 kgs	715 kgs / 810 kgs

*Specifications are subject to change without prior notice.

