

CEN03 Type Pressure-Relief PLC Electric Lubricator

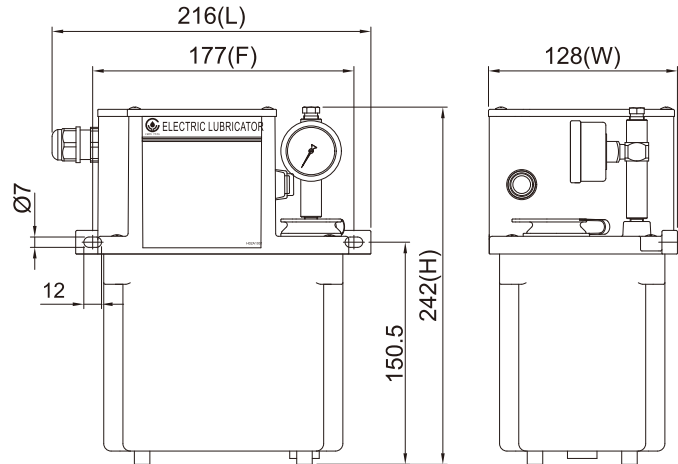

CEN03-01 Standard



CEN03-01 Standard Externals

◆ Features

1. CEN03 type is without timer (also could be controlled by Programmable Logic Controller) and has to work with volume distributors. With CAB or CBB type volume distributor, oil will feed during operation time. With CDB or T type volume distributor, oil will feed during interval time.
2. The discharge volume is fixed. The lubrication points of volume distributor supply a fixed flow of oil.
3. It has a spark-eliminator inside to prevent the sparks producing when the electric current is running. The spark-eliminator can avoid PLC (Programmable Logic Controller) being interfered.
4. CEN03 type has a pressure switch device and been set up as 8kg/cm², which assures the oil volume of lubrication point and check if the piping works normally. The standard specification is NC (Normal Close) contact, which means if the pressure is abnormal, it will have signal. NO (Normal Open) contact is available on request.
5. It has a float switch that can detect the oil volume. When oil is lower than the minimum level, the float switch will automatically send a continuous signal.
6. It has a pressure gauge where an operator can check the pressure easily.
7. Please don't press the force feed-oil (F) button more than three minutes in order to avoid overloading. When the temperature reaches 100°C, the sensor will be on to stop the motor continue running about 5 minutes.
8. Its function is similar to CEN04 type. The difference is that CEN03 type is without timer and CEN04 type is controlled by a timer. CEN01 and CEN02 types are resistance type lubricators.

◆ Application of Machines Equipment

1. It can be used for the machines requiring strictly rationing oil flow.
2. It is usually used for such as processing machines or projecting machines.

CEN03 Type Single Phase Wiring Diagram

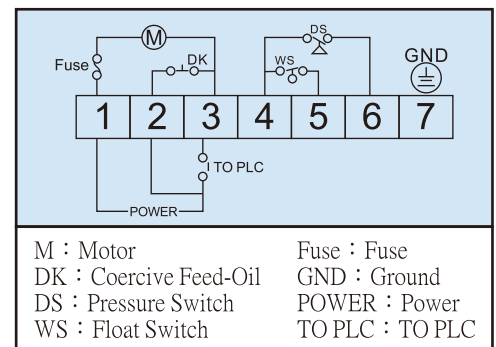

Model	Tank Code	Tank Material	Capacity Liters	Fixed Hole Distance(mm)	Length (mm)	Width (mm)	Height (mm)	Weight (kg)
CEN03	01	Resin	2 L	177	216	128	242	3.80
	02	Aluminum	2 L	95 x 200	225	151	233	4.55
	03	Resin	3 L	205	230	167	247	4.35
	04	Resin	4 L	250	277	162	265	4.75
	05	Aluminum	4 L	95 x 280	297	170	252	5.90
	08	Iron	8 L	95 x 338	355	200	273	8.65

Model	Act Time	Interval Time	Motor Output Watt	Max Volume	Max Pressure	1Ø Voltage	Ampere	Hertz	Discharge Bore	Oil Viscosity
CEN03	Control By PLC		30±3W	130 cc/min	15kgf/cm ²	110V 220V	2A 1A	60Hz or 50Hz	Ø4 or Ø6	32-68cSt@40°C

◆ Order code :

CEN 03	01	C	3	※
Model 03 : Pressure-Relief Type, Controlled by PLC	Tank Capacity (Material) 01 : 2L (Resin) 02 : 2L (Aluminum) 03 : 3L (Resin) 04 : 4L (Resin) 05 : 4L (Aluminum) 08 : 8L (Iron)	Voltage A : 110V,60Hz B : 220V,50Hz C : 220V,60Hz	Discharge Bore 0 : Ø4 1 : Ø6 2 : Ø4 (With Pressure Gauge) 3 : Ø6 (With Pressure Gauge)	Special Request ※B : Add a Buzzer ※Z : Increase the discharge volume to 260cc/min