



M8050

MPC 系列 前置式工作盤交換台
MPC SERIES FRONT MOUNTED PALLET CHANGE

產品特性 Features

多元應用 Versatile Applications

- 可搭各樣式立式加工中心機、平面研磨機等。
Applicable for various vertical machining centers and surface grinding machines, etc.
- 新舊工具機皆可安裝運用。
Suitable for use on a new or used machine tool.

模組設計 Modular Design

- 可設計適合各式的機床。
Customized design is available to suit various types of machine tools.
- 工作臺材質選可以依需求選定。
Choice of table materials to meet customer's requirement.

節能自動 Energy Saving & Automation

- 減少人工換工件的時間。
Reduce manual workpiece loading time.
- 增加及時加工效率。
Increase timely machining efficiency.
- 具氣密偵測功能。
With air sealing detection function.
- 防鬆機構設計。
Anti-loosen mechanism design.

備註：
特殊規格設計請與本公司聯絡。
工作盤上的工件治具以手動裝置為主。
規格與設計變更時恕不另行通知。

Remark:
When special design of specifications is required, please contact us.
The standard design of workpiece jigs on the table is manually operated.
Specifications and design are subjected to change without prior notice.

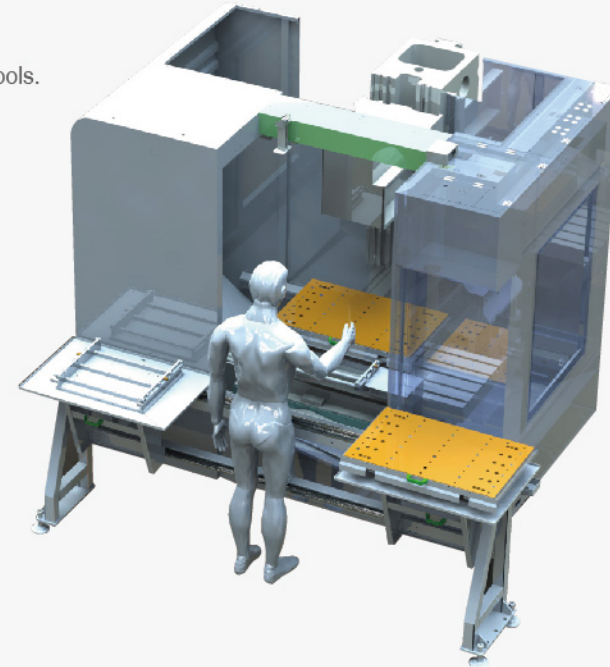

參考影片
Reference Video

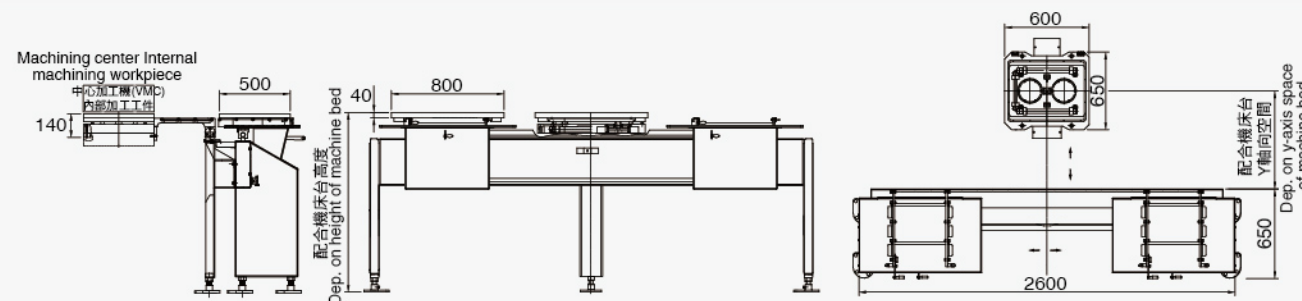

www.shengyumc.com.tw

側進式自動交換工作台
Lateral Feeding (Automatic) Pallet Changer

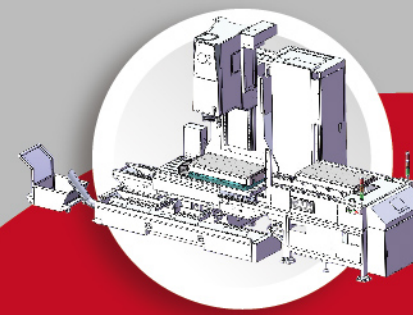

多盤式自動交換工作站
Multi Pallet Workstation



前置式工作盤交換台
Front Mounted Pallet Changer

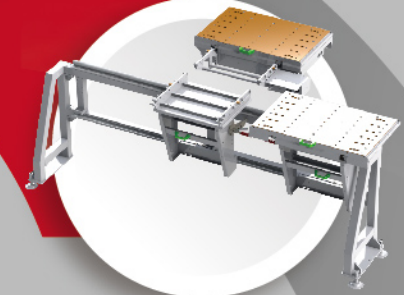

盛鈺精機 SHENG YU

自動化整合系統
Automatic System



油壓斜契雙夾虎鉗
Hydraulic Twin - Clamp
Vise With Taper Gib

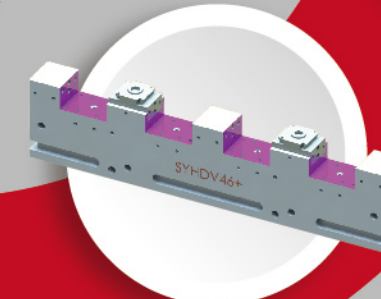

4+1 軸油壓轉台 / 夾治具
4+1-axis Hydraulic Rotary Unit /
Jig And Fixture

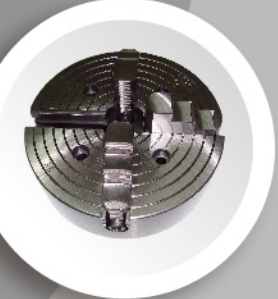
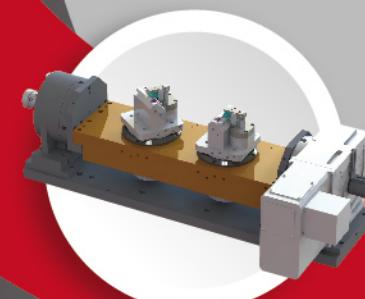

大型四爪單動夾頭
Large 4 - Jaw
Independent Chuck

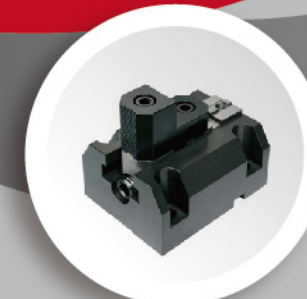

立車置爪
Clamping Jaw for Vertical Lathe



油壓煞車器
Hydraulic Brake



盛鈺精機有限公司

SHENG YU PRECISION MACHINE CO., LTD.

41282 台中市大里區仁美路 97 號

No.97, Renmei Rd., Dali Dist., Taichung City 41282, Taiwan.

Tel: +886-4-2492-3577

Fax: +886-4-2492-3977

E-mail: b3736@ms16.hinet.net

www.shengyumc.com.tw



ACW 2020.03.1000CE

夾治具 / 專用機 / 交換工作台 / 自動化系統整合

Jig And Fixture / Special Purpose Machine / Pallet Changer / Automatic System



APC1000-APC1600

APC 系列 側進式自動交換工作台
APC SERIES LATERAL FEEDING AUTOMATIC PALLET CHANGER



參考影片
Reference Video

產品特性 Features

多元應用 Versatile Applications

- 可搭各樣式立式加工中心機、平面研磨機等。
Applicable for various vertical machining centers and surface grinding machines, etc.
- 新舊工具機皆可安裝運用。
Suitable for use on a new or used machine tool.

模組設計 Modular Design

- 可配合各式的機型場地設計運用。
Customized design is available to suit various machine models and locations.
- APC材質選可以依需求選定。
Choice of APC materials to meet customer's requirement.
- (鑄件或鋁合金)。(Cast iron or aluminum alloy)

智能管理 Intelligent Management

- 人機操作管理面板。
Touch panel for user - friendly operation.
- 第四軸/夾具控制。
4th axis / fixture control

節能自動 Energy Saving & Automation

- 減少人工換工件的時間。
Reduce manual workpiece loading time.
- 增加及時加工效率。
Increase timely machining efficiency.
- 具氣密偵測功能。
With air sealing detection function.
- 防鬆機構設計。
Anti - loosen mechanism design.

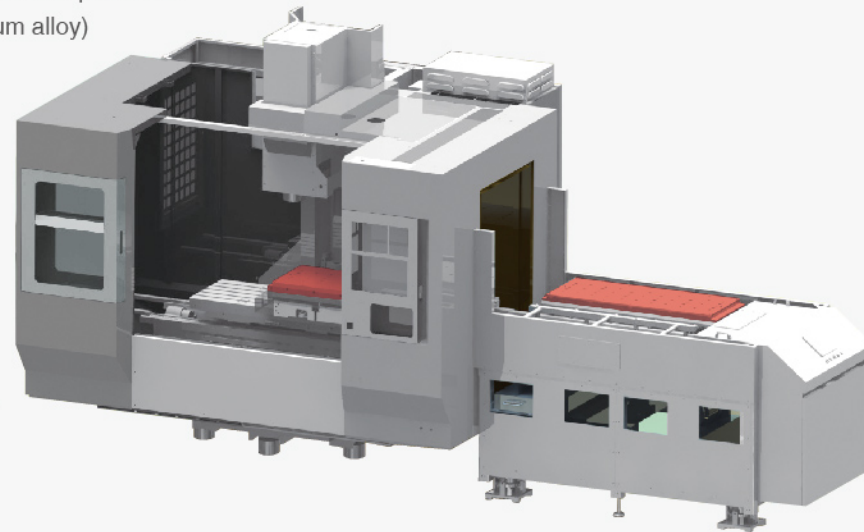

AMPC1012(10'') / AMPC1512(15'')

AMPC 系列 多盤式自動交換工作站
AMPC SERIES MULTI PALLET WORKSTATION



參考影片
Reference Video

產品特性 Features

多元應用 Versatile Applications

- 可搭各樣式立式加工中心機、5 軸加工機、平面研磨機等。
Applicable for various vertical machining centers and surface grinding machines, etc.
- 新舊工具機皆可安裝運用。
Suitable for use on a new or used machine tool.

模組設計 Modular Design

- 可配合各式的場地彈性運用。
Can be used at various locations.
- 可設計適合各式的機床。
Customized design is available to suit various types of machine tools.

智能管理 Intelligent Management

- 人機操作管理面板。
Touch panel for user - friendly operation.
- 工作台倉位指示功能。
Pallet position indication function.

節能自動 Energy Saving & Automation

- 減少人工換工件的時間。
Reduce manual workpiece loading time.
- 增加及時加工效率。
Increase timely machining efficiency.
- 工廠場地有效運用。
Effective utilization of factory space.
- 具氣密偵測功能。
With air sealing detection function.
- 防鬆機構設計。
Anti - loosen mechanism design.



前置式交換工作站
Front feeding workstation

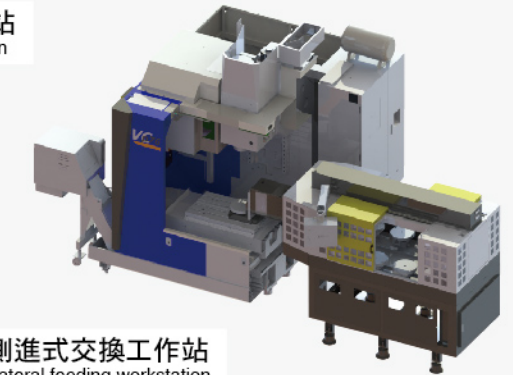

側進式交換工作站
Lateral feeding workstation

