

www.com.tw

tanko

SINCE 1975

· *Efficiency Master* ·

Catalogue No.144E



Workstation / Tool Cabinet / Workbench / Storage Shelves
Trolley / Parts Cabinet / Hanger Rack

Index

1

Modular Workstation

Professional	4
Classic	6

2

Workbench

Performance	9
Professional	10
Heavy Duty	12
Stainless Steel	17
Accessories	18

3

Tool Cabinet

Standard	21
Heavy Duty	24
CNC Tool	26
Trolley / Tilt Out Bins Cart	30

4

Mould Rack

Mould Rack	35
------------	----

5

Hanger Rack

Display Stand	37
Hanger Rack	38

6

Perforated Board

Perforated Board	41
Accessories	41

7

Documents & Parts Cabinet / Bin

Documents Cabinet	45
Parts Cabinet	46
Tilt Out Bin / Team Case	49
Team Bin	50



Modular Workstation

Cabinet H970



RPW-09S + RA-9091

W900xD510xH970

With 2 Shelves
Loading : 100kg / Shelve



RPW-06S + RA-6091

W620xD510xH970

With 2 Shelves
Loading : 100kg / Shelve

Tool Cabinet



RPW-06S + RB-6098

W620xD510xH970

Drawer loading : 45kg



RPW-06S + RC-6094

W620xD510xH970

Drawer loading : 45kg



EGL-177M

W755xD510xH850

Drawer loading : 45kg

Cabinet H2020



Storage Cabinet

RA-9201

W900xD510xH2020

With 4 Shelves
Loading : 100kg / Shelve



Storage Cabinet

RA-6201

W620xD510xH2020

With 4 Shelves
Loading : 100kg / Shelve



Clothes Locker

RE-6201

W620xD510xH2020

With 2 Shelves
Loading : 100kg / Shelve

Sink Cabinet



RD-6091

W620xD510xH1220

Wastebin Cabinet



RPW-06S + RG-6091

W620xD510xH970

Desktop



Wood Top

EDAB-062505

W620xD500xH50

EDAB-090505

W900xD500xH50



Stainless Steel Top

RPW-06S

W620xD500xH50

RPW-09S

W900xD500xH50

RPW-12S

W1240xD500xH50

Stiffening Plate



RPW-06D

W620xD500xH40

RPW-09D

W900xD500xH40

A stiffening plate is needed while choosing the wood top without cabinet underneath.

Pole



RPA-1

W40xD30xH1950

Set of two

Panel

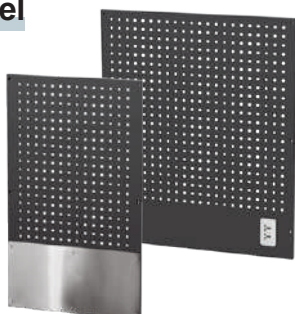

With Socket

RPQ-6063A

W610xD45xH645

RPQ-9063A

W890xD45xH645

RPQ-6103A

W610xD45xH1045

RPQ-9103A

W890xD45xH1045

Universal Socket 110V~220V x 2

Power plugs not included.

With Water Baffle

RPQ-6062

W610xD24xH645

RPQ-6102

W610xD24xH1045

Wall Cabinet



RPH-61

W620xD330xH400



RPH-91

W900xD330xH400

Combination



Combination 1

RY-01SA W1240xD540XH2020

1 RPH-61 Wall Cabinet x1	2 RPH-61 Wall Cabinet x1
RPQ-6063A Panel with Socket x1	RPQ-6063A Panel with Socket x1
RB-6098 Tool Cabinet x1	RA-6091 Storage Cabinet x1
RPW-12S Stainless Steel Top x1 (1,2 Shared)	

Includes RPA-1 Pole x 2 (4pcs)

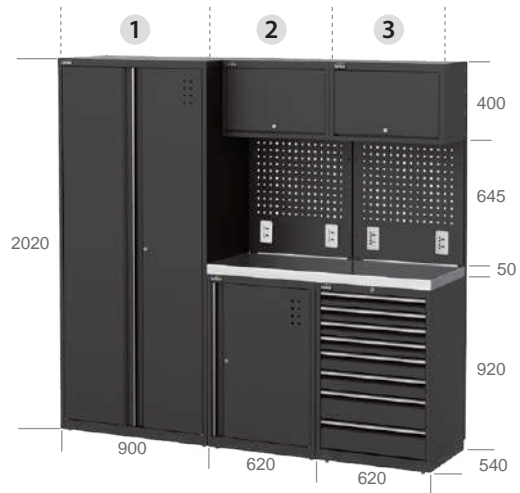

Combination 2

RY-02SA W2140xD540XH2020

1 RA-9201 Storage Cabinet x1	3 RPH-61 Wall Cabinet x1
2 RPH-61 Wall Cabinet x1	RPQ-6063A Panel with Socket x1
RPQ-6063A Panel with Socket x1	RB-6098 Tool Cabinet x1
RA-6091 Storage Cabinet x1	RPW-12S Stainless Steel Top x1 (2,3 Shared)

Includes RPA-1 Pole x 2 (4pcs)

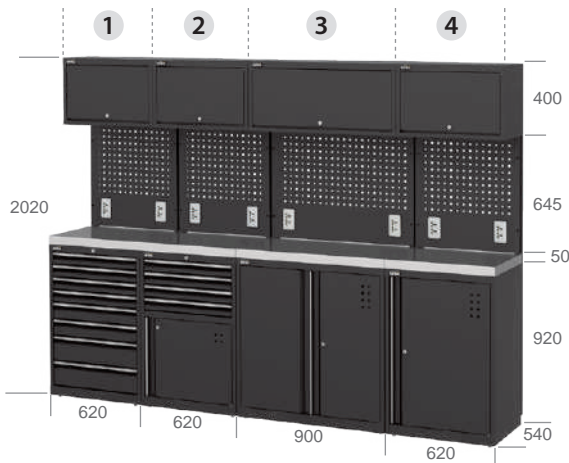

Combination 3

RY-03SA W2760xD540XH2020

1 RPH-61 Wall Cabinet x1	2 RPH-61 Wall Cabinet x1
RPQ-6063A Panel with Socket x1	RPQ-6063A Panel with Socket x1
RB-6098 Tool Cabinet x1	RC-6094 Tool Cabinet x1
RPW-12S Stainless Steel Top x1 (1,2 Shared)	
3 RPH-91 Wall Cabinet x1	4 RPH-61 Wall Cabinet x1
RPQ-9063A Panel with Socket x1	RPQ-6063A Panel with Socket x1
RPW-09S Stainless Steel Top x1	RPW-06S Stainless Steel Top x1
RA-9091 Storage Cabinet x1	RA-6091 Storage Cabinet x1

Includes RPA-1 Pole x 4 (8pcs)

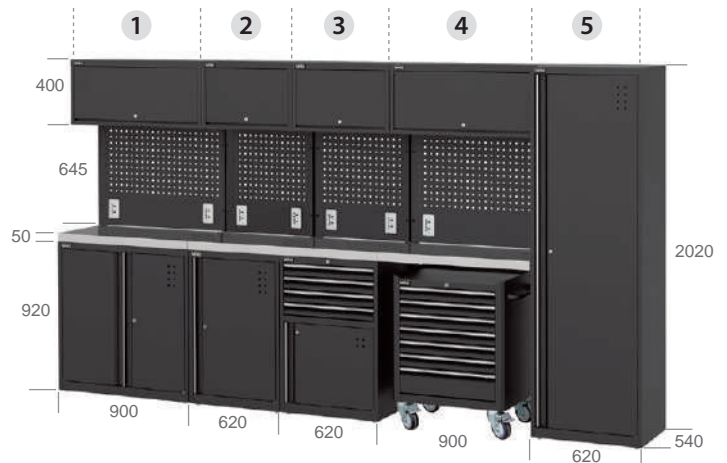

Combination 4

RY-04SA W3660xD540XH2020

1 RPH-91 Wall Cabinet x1	2 RPH-61 Wall Cabinet x1
RPQ-9063A Panel with Socket x1	RPQ-6063A Panel with Socket x1
RPW-09S Stainless Steel Top x1	RA-6091 Storage Cabinet x1
RA-9091 Storage Cabinet x1	4 RPH-91 Wall Cabinet x1
3 RPH-61 Wall Cabinet x1	RPQ-9063A Panel with Socket x1
RPQ-6063A Panel with Socket x1	RPW-09S Stainless Steel Top x1
RC-6094 Tool Cabinet x1	EGL-177M Tool Cabinet x1
RPW-12S Stainless Steel Top x1 (2,3 Shared)	

5 RE-6201 Clothes Locker x 1

Includes RPA-1 Pole x 4.5 (9pcs)

Cabinet H1780



SAQ-361

W900xD515xH1780



SAA-361

W900xD515xH1780

With 4 Shelves
Loading : 200kg / Shelf



SAQ-362

W900xD515xH1780

Drawer loading : 45kg



SAA-362

W900xD515xH1780

Drawer loading : 45kg
With 3 Shelves
Loading : 200kg / Shelf

Cabinet H900



SAA-331

W900xD515xH900

With 2 Shelves
Loading : 200kg / Shelf



SAA-231

W600xD515xH900

With 2 Shelves
Loading : 200kg / Shelf

Tool Cabinet



SAB-331

W900xD515xH900

Drawer loading : 45kg
With 2 Shelves
Loading : 100kg / Shelf



SG-23071

W600xD510xH900

Drawer loading : 45kg

Wastebin Cabinet



SAG-231

W600xD515xH900

Drawer Rack

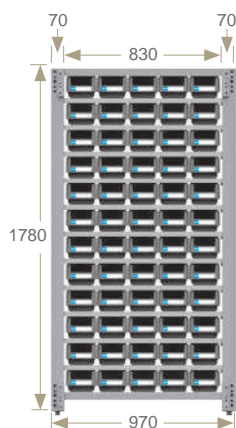

Independent

SCA-361

SCB-361

W970xD500xH1780

Drawer : 60 pcs

Drawer : 30 pcs

With 1 Shelf
Loading : 100kg



Linkable

SCA-362

SCB-362

W900xD500xH1780

Drawer : 60 pcs

Drawer : 30 pcs

With 1 Shelf
Loading : 100kg

Modular Rack

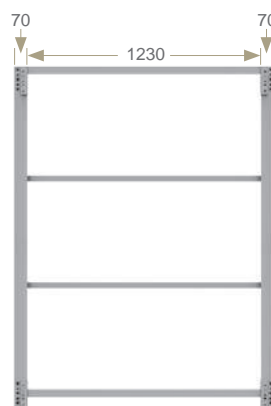

Independent

SCC-461

W1370xD500xH1780

With 2 Shelves
Loading : 200kg

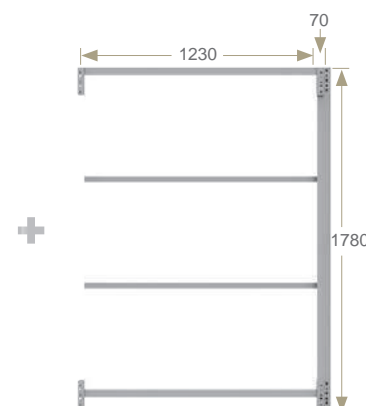

Linkable

SCC-462

W1300xD500xH1780

With 2 Shelves
Loading : 200kg

Desktop



Steel Top

SPW-3	SPW-4
W900xD500xH50	W1200xD500xH50



Stainless Steel Top

SPW-3S	SPW-4S
W900xD500xH50	W1200xD500xH50

Panel

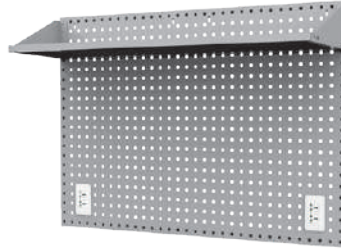

SPQ-32A	SPQ-33A	SPQ-42A	SPQ-43A
W900xD325xH825		W1200xD325xH825	
Panel : W900xH825mm Shelf : W895xD300xH28mm		Panel : W1200xH825mm Shelf : W1195xD300xH28mm	
Universal Socket 110V~220V x 2			
—		Light:10W LED	

Power plugs not included.

Pole



SPA-1
W74xD40xH1757

Combination

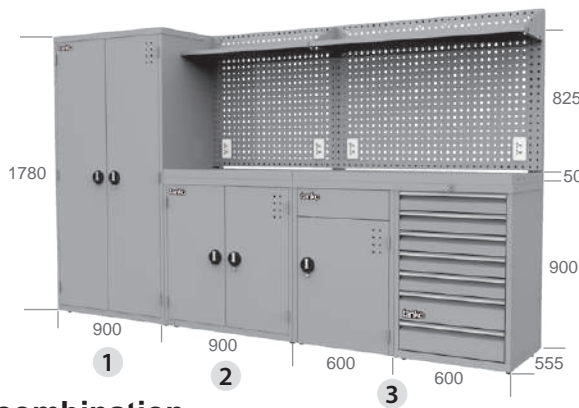

A combination

SY-01A W3000xD555XH1780

1 SAA-361 Storage Cabinet x1	3 SPQ-43A Panel set with light x1
2 SPQ-33A Panel set with light x1	SPW-4 Steel Top x1
SPW-3 Steel Top x1	SAG-231 Wastebin Cabinet x1
SAA-331 Storage Cabinet x1	SG-23071 Tool Cabinet x1

Includes SPA-1 Pole x 3

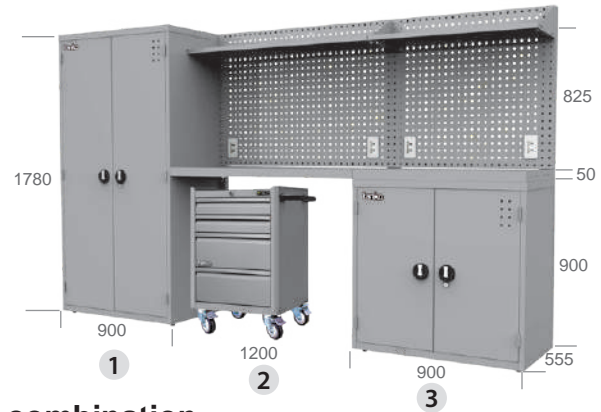

B combination

SY-02A W3000xD555XH1780

1 SAA-361 Storage Cabinet x1	3 SPQ-33A Panel set with light x1
2 SPQ-43A Panel set with light x1	SPW-3 Steel Top x1
SPW-4 Steel Top x1	SAA-331 Storage Cabinet x1
EGA-7041M Tool Cabinet is optional, refer to P21	

Includes SPA-1 Pole x 3

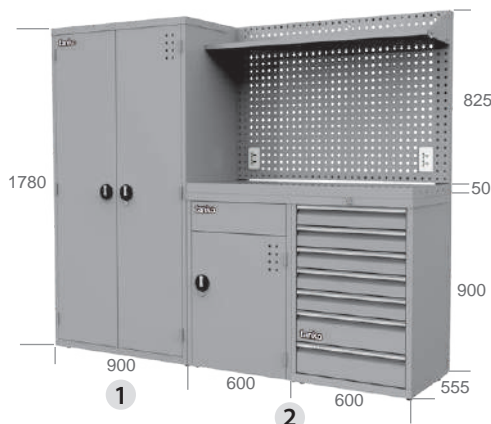

C combination

SY-03A W2100xD555XH1780

1 SAA-361 Storage Cabinet x1	2 SPQ-43A Panel set with light x1
	SPW-4 Steel Top x1
	SAG-231 Wastebin Cabinet x1
	SG-23071 Tool Cabinet x1

Includes SPA-1 Pole x 2

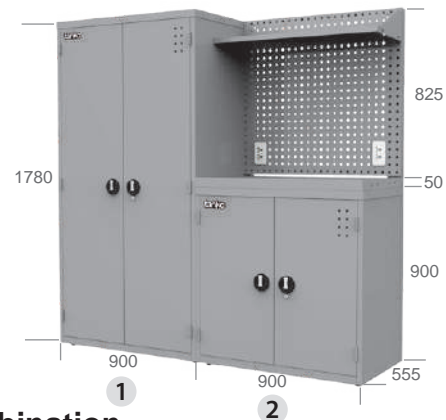

D combination

SY-04A W1800xD555XH1780

1 SAA-361 Storage Cabinet x1	2 SPQ-33A Panel set with light x1
	SPW-3 Steel Top x1
	SAA-331 Storage Cabinet x1

Includes SPA-1 Pole x 2

Unit of Measurement : mm



Workbench

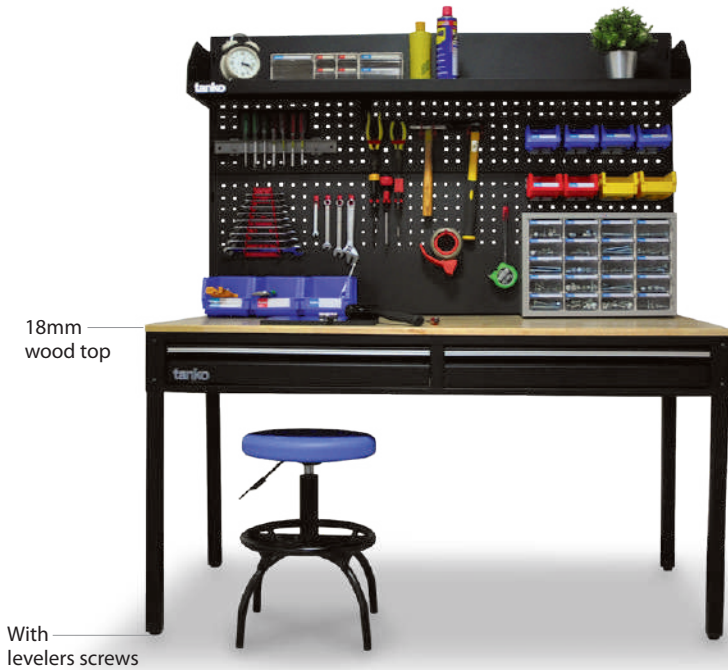

18mm wood top

With levelers screws



Extra shelf for extra storage space



Perforated board can be used with all Tanko hangers
Refer to P41~P43



Cable grommet



○ ●	WE-47W	W1200xD600xH750
○ ●	WE-58W	W1500xD750xH800



○ ●	WE-47W3	W1200xD620xH1355
○ ●	WE-58W3	W1500xD770xH1710



○ ●	WE-47W4	W1200xD620xH1355
○ ●	WE-58W4	W1500xD770xH1710
○ ●	WE-47W5	W1200xD620xH1355 Light WP-9003
○ ●	WE-58W5	W1500xD770xH1710 Light WP-9003 + WP-9004



○ ●	WET-4102W	W1200xD610xH750
○ ●	WET-5102W	W1500xD760xH800



○ ●	WET-4102W3	W1200xD625xH1355
○ ●	WET-5102W3	W1500xD775xH1710



○ ●	WET-4102W4	W1200xD625xH1355
○ ●	WET-5102W4	W1500xD775xH1710
○ ●	WET-4102W5	W1200xD625xH1355 Light WP-9003
○ ●	WET-5102W5	W1500xD775xH1710 Light WP-9003 + WP-9004

Workbench-Top Type

Dimension

Features

N

Rubber top

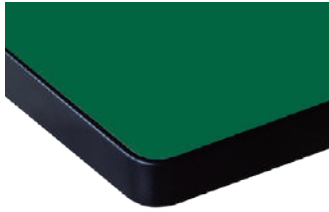

W1500
x D750 x H30
W1800

High density fiberboard(HDF) covered with green rubber mat on top and PVC protection on four edges.

F

Laminate top

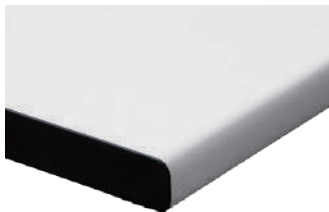

W1500
x D750 x H30
W1800

Plywood top covered with gray laminate and PVC protective edges, great performance in high temperature environment.

W

Wood top



W1500
x D750 x H30
W1800

Finger-jointed rubber wood to ensure high durability.



KG 600kg load capacity



Various Types of
Drawer / Base Designs

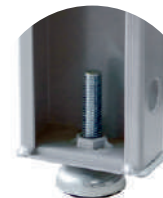

With
levelers screws



Perforated panels
are optional
Refer to P18



Standard

DIM.	Rubber top N	Laminate top F	Wood top W
W1500xD750xH800	WB-57N	WB-57F	WB-57W
W1800xD750xH800	WB-67N	WB-67F	WB-67W



Drawers

DIM.	Rubber top N	Laminate top F	Wood top W
W1500xD750xH800	WBT-5203N	WBT-5203F	WBT-5203W
W1800xD750xH800	WBT-6203N	WBT-6203F	WBT-6203W

KG 50kg load capacity per drawer

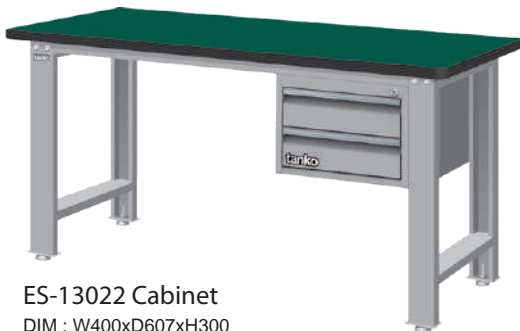

Hanging Cabinet

DIM.	Rubber top N	Laminate top F	Wood top W
W1500xD750xH800	WBS-53022N	WBS-53022F	WBS-53022W
W1800xD750xH800	WBS-63022N	WBS-63022F	WBS-63022W

ES-13022 Cabinet
DIM : W400xD607xH300

KG 45kg load capacity per drawer



Tool Cabinet

DIM.	Rubber top N	Laminate top F	Wood top W
W1500xD750xH1400	WB-57N6A	WB-57F6A	WB-57W6A
W1800xD750xH1400	WB-67N6A	WB-67F6A	WB-67W6A



W566xD510xH700	EGA-7041
----------------	-----------------

Power plugs not included.

EGA-7041 Tool Cabinet

KG 45kg load capacity per drawer

Refer to P21

Workbench-Top Type

Dimension

Features

N

Rubber top

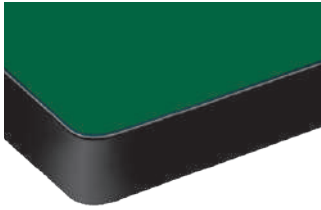

W1500
W1800 x D750 x H50
W2100

High density fiberboard(HDF) covered with green rubber mat on top and PVC protection on four edges.

F

Laminate top



W1500
W1800 x D750 x H50
W2100

Plywood top covered with gray laminate and PVC protective edges, great performance in high temperature environment.

W

Wood top



W1500
W1800 x D750 x H50
W2100

Finger-jointed rubber wood to ensure high durability.

S

Stainless steel top

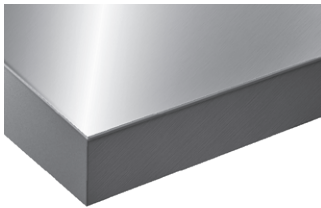

W1500
W1800 x D750 x H50
W2100

High density material covered with 1.2mm stainless steel sheet.

T

Tanko top



W1500 x D750 x 36(TG)
W1800 x D750 x 43(TH)

Multi-layer laminate and PVC protection on four edges.

A

Benchwork top

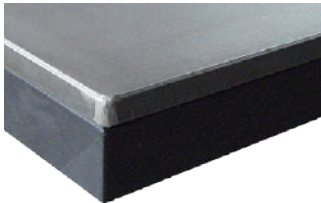

W1500 x D750 x H50
W1800

36mm base material covered with 9mm steel plate.

P.Q

Steel top



W1500 x D750 x H50
W1800

Made from 2mm steel, covered with 10mm black rubber mat(P) or 12mm PVC mat(Q).



Various Types of
Drawer / Base Designs



With
levelers screws



Perforated panels
are optional
Refer to P18

KG 2000kg load capacity
KG 1000kg load capacity (Mobile type)

Workbench-top types Refer to P12

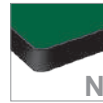

Rubber top

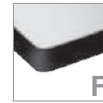

Laminate top



Wood top



Stainless steel
top



Tanko top

(TG)H36mm
(TH)H43mm



Standard

Workbench-top	N	F	S	W	TG	TH
DIM.	WxDxH				WxDxH	
WA-57	1500x750x800				1500x750x786	1500x750x793
WA-67	1800x750x800				1800x750x786	1800x750x793
WA-77	2100x750x800				—	—

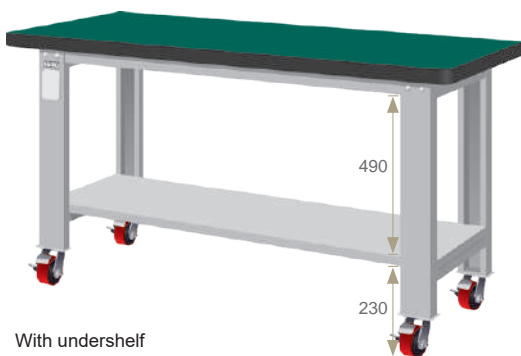

With undershelf

Mobile

Workbench-top	N	F	S	W	TG	TH
DIM.	WxDxH				WxDxH	
WA-57	1500x750x850				1500x750x836	1500x750x843
WA-67	1800x750x850				1800x750x836	1800x750x843

Model Code: WA-57 N / Workbench-Top Types

Unit of Measurement : mm

Workbench-top types [Refer to P12](#)

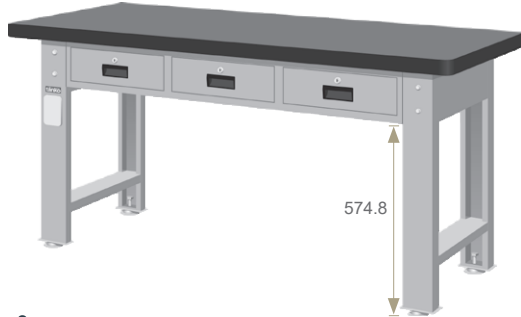
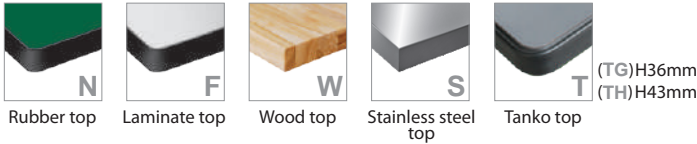

KG 50kg load capacity per drawer

Drawers

Workbench-top	N	F	S	W	TG	TH
DIM.	WxDxH				WxDxH	
WAT-5203 <input type="checkbox"/>	1500x750x800				1500x750x786	1500x750x793
WAT-6203 <input type="checkbox"/>	1800x750x800				1800x750x786	1800x750x793



Cabinet DIM : W566xD607xH380

KG 100kg load capacity per drawer

[Refer to P24](#)

Hanging Cabinet

Workbench-top	N	F	S	W	TG	TH
DIM.	WxDxH				WxDxH	
WAS-54031 <input type="checkbox"/>	1500x750x800				1500x750x786	1500x750x793
WAS-64031 <input type="checkbox"/>	1800x750x800				1800x750x786	1800x750x793
WAS-74031 <input type="checkbox"/>	2100x750x800				—	—

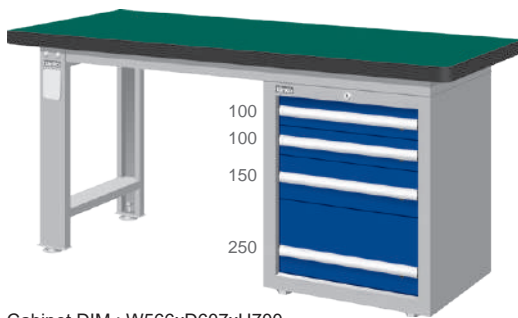

Cabinet DIM : W566xD607xH700

KG 100kg load capacity per drawer

[Refer to P25](#)

Tool Cabinet

Workbench-top	N	F	S	W	TG	TH
DIM.	WxDxH				WxDxH	
WAS-57042 <input type="checkbox"/>	1500x750x800				1500x750x786	1500x750x793
WAS-67042 <input type="checkbox"/>	1800x750x800				1800x750x786	1800x750x793
WAS-77042 <input type="checkbox"/>	2100x750x800				—	—

Heavy Duty Workbench

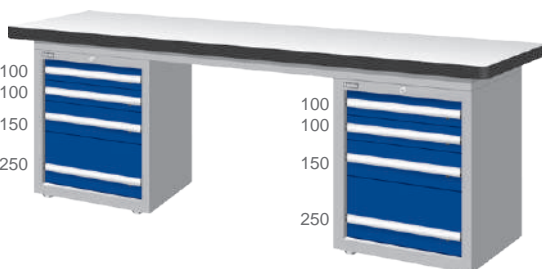

Cabinet DIM : W566xD607xH700

KG 100kg load capacity per drawer

[Refer to P25](#)

Double Tool Cabinet

Workbench-top	N	F	S	W
DIM.	WxDxH			
WAD-77042 <input type="checkbox"/>	2100x750x800			

Model Code: WAT-5203 N / Workbench-Top Types

Unit of Measurement : mm

Benchwork top

Refer to P12

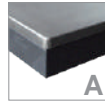

2000kg load capacity
With undershelf

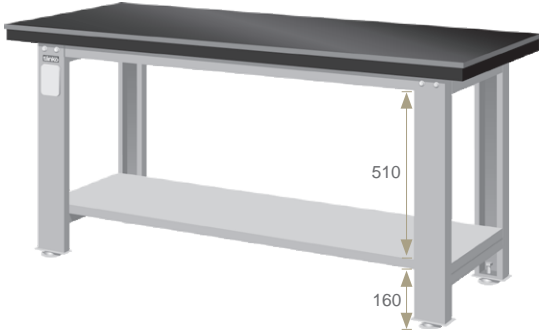

Standard

DIM.	A Benchwork top
W1500xD750xH800	WA-57A
W1800xD750xH800	WA-67A

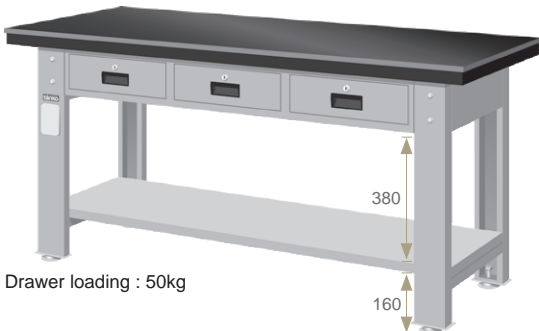

Drawer loading : 50kg

Drawers

DIM.	A Benchwork top
W1500xD750xH800	WAT-5203A
W1800xD750xH800	WAT-6203A



Cabinet DIM : W566xD607xH380
Drawer loading : 100kg Refer to P24

Hanging Cabinet

DIM.	A Benchwork top
W1500xD750xH800	WAS-54031A
W1800xD750xH800	WAS-64031A

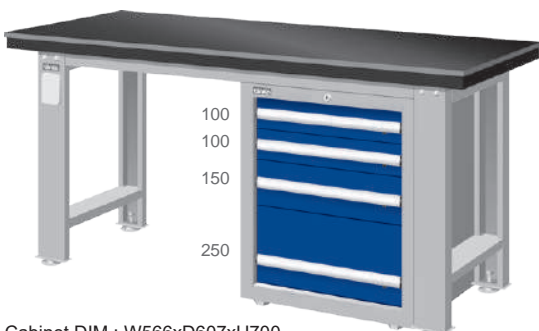

Cabinet DIM : W566xD607xH700
Drawer loading : 100kg Refer to P25

Tool Cabinet

DIM.	A Benchwork top
W1500xD750xH800	WAS-57042A
W1800xD750xH800	WAS-67042A

Steel top

Refer to P12



P : 10mm Rubber mat
Q : 12mm PVC mat

KG 2000kg load capacity



EA-7042 Refer to P25



EGA-7041 Refer to P21



Standard

P Rubber mat	WD-58P	W1524xD775xH810
	WD-68P	W1824xD775xH810
Q PVC mat	WD-58Q	W1524xD775xH812
	WD-68Q	W1824xD775xH812



ES-13022 Cabinet
DIM : W400xD607xH300
Drawer loading : 45kg

Hanging Cabinet

P Rubber mat	WD-5801P	W1524xD775xH810
	WD-6801P	W1824xD775xH810
Q PVC mat	WD-5801Q	W1524xD775xH812
	WD-6801Q	W1824xD775xH812



Standard with Panel Set

P Rubber mat	WD-58P6A	W1524xD775xH1410
	WD-68P6A	W1824xD775xH1410
Q PVC mat	WD-58Q6A	W1524xD775xH1410
	WD-68Q6A	W1824xD775xH1410

Power plugs not included.



Hanging Cabinet with Panel Set

P Rubber mat	WD-5801P9A	W1524xD775xH1710
	WD-6801P9A	W1824xD775xH1710
Q PVC mat	WD-5801Q9A	W1524xD775xH1710
	WD-6801Q9A	W1824xD775xH1710

Power plugs not included.

Stainless Steel Workbench



KG 600kg load capacity



Various Types of
Drawer / Base Designs



With
levelers screws



Perforated panels
are optional
Refer to P18



WD-48S

W1217xD768xH800

WD-58S

W1517xD768xH800

WD-68S

W1817xD768xH800



Drawer loading : 35kg

Two Drawers

WDT-4202S

W1217xD768xH800

Three Drawers

WDT-5203S

W1517xD768xH800

WDT-6203S

W1817xD768xH800

Workbench Accessories

Panel Set

For both professional and heavy duty workbench

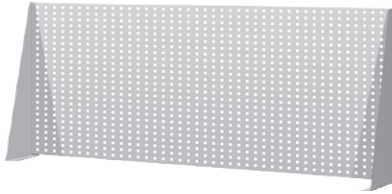

WQ-52	W1502xD202xH603
WQ-62	W1802xD202xH603

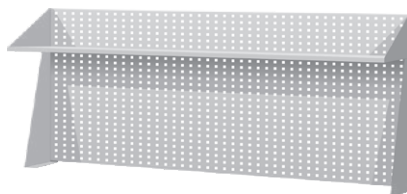

WQ-53	W1502xD325xH603
WQ-63	W1802xD325xH603

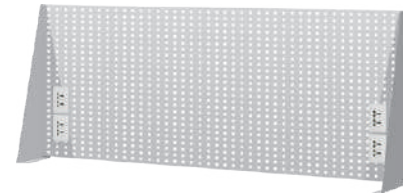

WQ-54A	W1502xD202xH603
WQ-64A	W1802xD202xH603

Universal Socket 110V~220V x 4
Power plugs not included

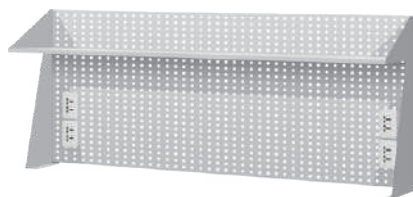

WQ-55A	W1502xD325xH603
WQ-65A	W1802xD325xH603

Universal Socket 110V~220V x 4
Power plugs not included

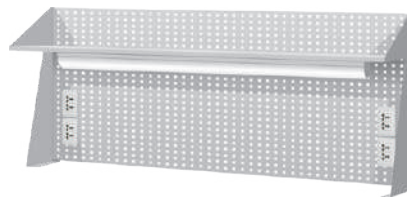

WQ-56A	W1502xD325xH603
WQ-66A	W1802xD325xH603

Universal Socket 110V~220V x 4
20W LED Light
Power plugs not included



WQ-67A	W1780xD450xH564
---------------	-----------------

Parts Cabinet DIM : W218xD420xH540
Universal Socket 110V~220V x 4
20W LED Light
Power plugs not included

For steel-top workbench

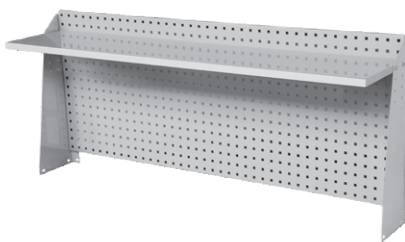

WQD-53	W1517xD320xH658
WQD-63	W1817xD320xH658

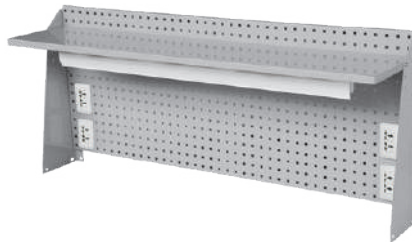

WQD-56A	W1517xD320xH658
WQD-66A	W1817xD320xH658

Universal Socket 110V~220V x 4
20W LED Light
Power plugs not included

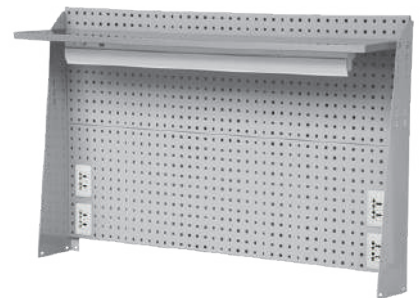

WQD-59A	W1517xD320xH958
WQD-69A	W1817xD320xH958

Universal Socket 110V~220V x 4
20W LED Light
Power plugs not included

For stainless steel workbench

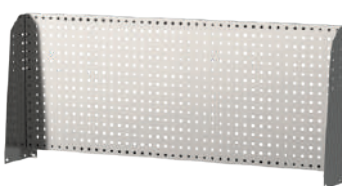

WQD-42S	W1209xD202xH645
WQD-52S	W1509xD202xH645
WQD-62S	W1809xD202xH645



WQD-43S	W1209xD320xH645
WQD-53S	W1509xD320xH645
WQD-63S	W1809xD320xH645

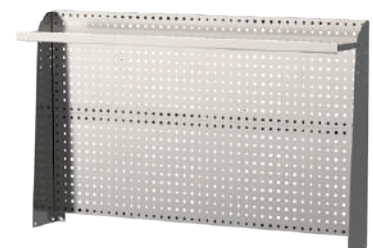

WQD-47S	W1209xD320xH945
WQD-57S	W1509xD320xH945
WQD-67S	W1809xD320xH945

Unit of Measurement : mm

Undershelf



For heavy duty workbench

WP-41	W1400xD509xH30
WP-42	W1700xD509xH30
WP-43	W2000xD509xH30



For stainless steel workbench

WDP-14S	W1200xD655xH30
WDP-15S	W1500xD655xH30
WDP-16S	W1800xD655xH30

Shelf

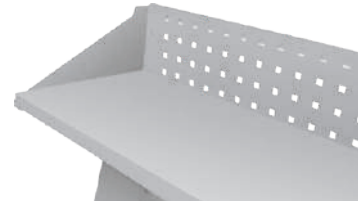

KP-19	W1500xD300
KP-20	W1800xD300
KP-21	W2100xD300

Light



LED Light

WP-9002
W1150xD22xH39
20W

Air Coupling



WP-9021	2 hole
----------------	--------

Socket



WP-9013A	110V~220V
-----------------	-----------

Workbench Seating



WP-625011
W 350
D 350
H 480



WP-625023
W 350
D 350
H 500~640



WP-61301
W 330 (Cushion)
D 600
H 400~510



WP-61102
W 430
D 490~530
H 810~925



Tool Cabinet



The specially designed lock gives higher durability.



Drawer latch

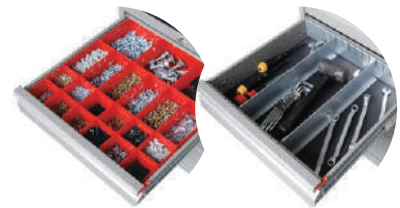

Division boxes and dividers are optional
Refer to P22

45kg per drawer

EGA Tool Cabinet



EGA-7041
W566xD510xH700

EGA-10061
W566xD510xH1000

EGA-10091
W566xD510xH1000

EGA-5041M
W568xD510xH690

EGA-7041M
W650xD510xH845

EGM Tool Cabinet



EGM-1703M
W1165xD510xH847
With 1 Shelves, Loading : 60kg

EGM-1703MA
W1165xD510xH1300
With 1 Shelves, Loading : 60kg
KPQ-B x 1 set

EGM-1705M
W1165xD510xH847
With 1 Shelves, Loading : 60kg

EGM-1705MA
W1165xD510xH1300
With 1 Shelves, Loading : 60kg
KPQ-B x 1 set

Standard Tool Cabinet

EGL Tool Cabinet



EGL-185M

W755xD510xH986



EGL-187M

W755xD510xH986



EGL-185MA

W755xD510xH1441

KPQ-B x 1set



EGL-187MA

W755xD510xH1441

KPQ-B x 1set

Accessories For EGA / EGL / EGM tool cabinet

Division Boxes



▲ Application

Division Boxes Configuration

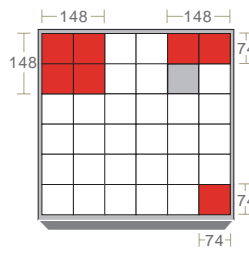

EGA types

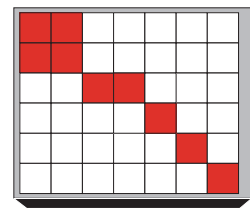

EGL / EGM types

Drawer Height 75mm		Drawer Height 100mm	
TK-8721	W74xD74xH45	TK-8731	W74xD74xH70
TK-8722	W148xD74xH45	TK-8732	W148xD74xH70
TK-8723	W148xD148xH45	TK-8733	W148xD148xH70

Adjustable Partitions



▲ Application

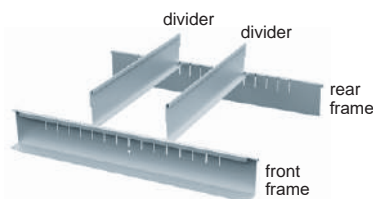

For EGA Tool Cabinet

Type	EGPA-3	EGPA-4	EGPA-5
Drawer Height	100mm	150mm	200mm

divider x2 / rear frame x1 / front frame x1

For EGL / EGM Tool Cabinet

Type	EGPL-2	EGPL-3	EGPL-4
Drawer Height	75mm	100mm	150mm

divider x2 / rear frame x1 / front frame x1

Top Chest



For EGL Tool Cabinet



EGP-03L

W663xD518xH120

with PVC mat

For EGM Tool Cabinet



EGP-03M

W1073xD518xH120

with PVC mat



4"PU casters
(ELS)

5"PU casters
(ELA)



The specially designed lock gives higher durability.



Drawer latch

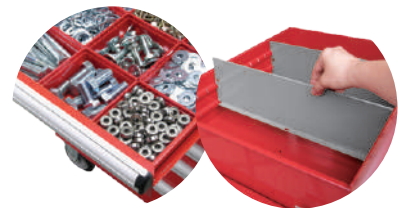

1st drawer includes division boxes. The others include partitions.

KG 50kg per drawer

ELA Tool Cabinet



ELA-185M

W690xD510xH1010



ELA-185MA

W690xD510xH1475

KPQ-B x 1set



ELA-187M

W690xD510xH1010



ELA-187MA

W690xD510xH1475

KPQ-B x 1set

ELS Tool Cabinet



ELS-274M

W1060xD515xH865

With 1 Shelves, Loading : 60kg



ELS-274MA

W1060xD515xH1340

With 1 Shelves, Loading : 60kg

KPQ-B x 1set



ELS-276M

W1060xD515xH865

With 1 Shelves, Loading : 60kg



ELS-276MA

W1060xD515xH1340

With 1 Shelves, Loading : 60kg

KPQ-B x 1set

Standard Tool Cabinet



The specially designed lock gives higher durability.



Drawer latch



Full-length aluminum handles and labels.

Drawer Features ▼

1.Special bearing slide system

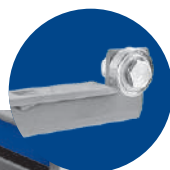

Standard Drawer
90% extension
100kg load capacity

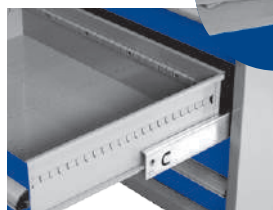

T Drawer
100% extension
200kg load capacity

2.Drawer layout



1st Drawer
Includes division boxes

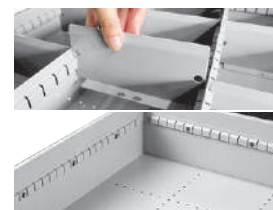

Others Drawers
Include adjustable metal dividers

Accessories

Top Chest



For EA Tool Cabinet

EP-0533

W566xD631xH120

with PVC mat

For EB Tool Cabinet

EP-0543

W718xD631xH120

with PVC mat

For ED Tool Cabinet

EP-0544

W718xD783xH120

with PVC mat

Tool Cabinet

Standard drawer loading 100kg ; T drawer loading 200kg

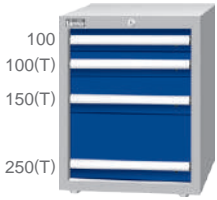

EA-7042(T)
W566xD607xH700

EB-7042(T)
W718xD607xH700

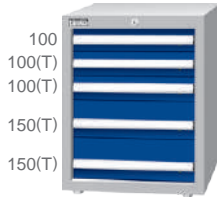

EA-7051(T)
W566xD607xH700

EB-7051(T)
W718xD607xH700

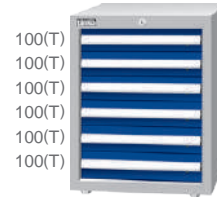

EA-7061(T)
W566xD607xH700

EB-7061(T)
W718xD607xH700

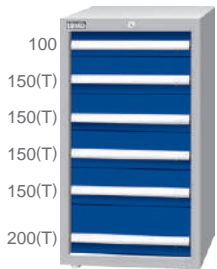

EA-10062(T)
W566xD607xH1000

EB-10062(T)
W718xD607xH1000

ED-10062(T)
W718xD759xH1000

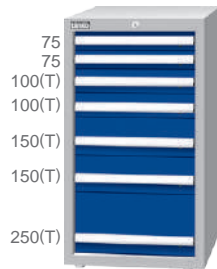

EA-10073(T)
W566xD607xH1000

EB-10073(T)
W718xD607xH1000

ED-10073(T)
W718xD759xH1000

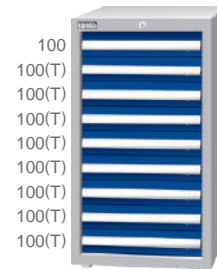

EA-10091(T)
W566xD607xH1000

EB-10091(T)
W718xD607xH1000

ED-10091(T)
W718xD759xH1000

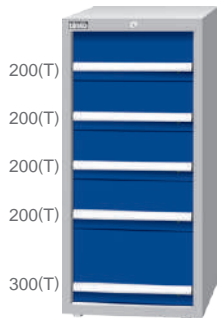

EA-12052(T)
W566xD607xH1200

EB-12052(T)
W718xD607xH1200

ED-12052(T)
W718xD759xH1200

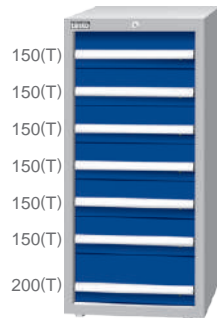

EA-12071(T)
W566xD607xH1200

EB-12071(T)
W718xD607xH1200

ED-12071(T)
W718xD759xH1200

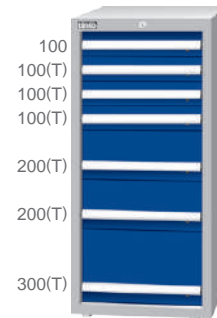

EA-12074(T)
W566xD607xH1200

EB-12074(T)
W718xD607xH1200

ED-12074(T)
W718xD759xH1200

Mobile Tool Cabinet

Drawer loading 100kg



EA-7042M
W566xD640xH850

EB-7042M
W718xD640xH850



EA-7051M
W566xD640xH850

EB-7051M
W718xD640xH850

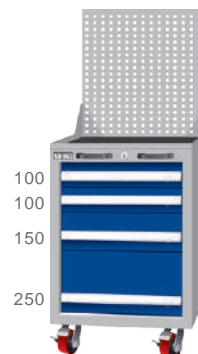

EA-7042MA
W566xD640xH1380

EB-7042MA
W718xD640xH1380

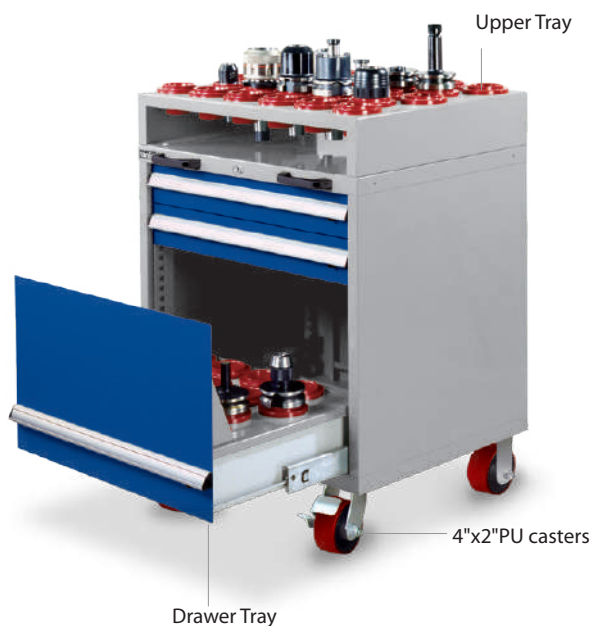

The specially designed lock gives higher durability.



Drawer latch



Adjustable metal dividers.

Drawer Tray (Qty)				
Type	EA	EB	ED	
BT-30	25 pcs	33 pcs	46 pcs	
BT-40	23 pcs	28 pcs	39 pcs	
BT-50	10 pcs	18 pcs	23 pcs	
HSK-40	25 pcs	33 pcs	46 pcs	
HSK-63	10 pcs	18 pcs	23 pcs	

Upper Tray (Qty)				
Type	EA	EB	ED	
BT-30	36 pcs	53 pcs	72 pcs	
BT-40	30 pcs	39 pcs	52 pcs	
BT-50	23 pcs	28 pcs	33 pcs	
HSK-40	36 pcs	53 pcs	72 pcs	
HSK-63	20 pcs	28 pcs	33 pcs	

CNC Tool Cabinet

Standard drawer loading 100kg ; T drawer loading 200kg

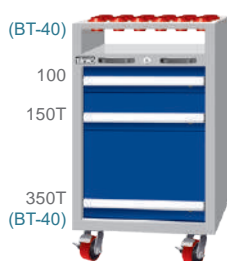

EA-7031-22MN W566xD640xH994
EB-7031-22MN W718xD640xH994
ED-7031-22MN W718xD792xH994

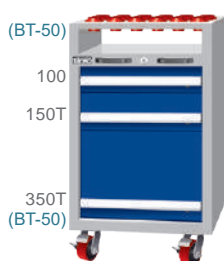

EA-7031-33MN W566xD640xH994
EB-7031-33MN W718xD640xH994
ED-7031-33MN W718xD792xH994

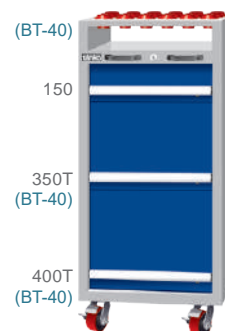

EA-10031-222MN W566xD640xH1291
EB-10031-222MN W718xD640xH1291
ED-10031-222MN W718xD792xH1291

Mobile CNC Tool Cabinet

Standard drawer loading 100kg ; T drawer loading 200kg

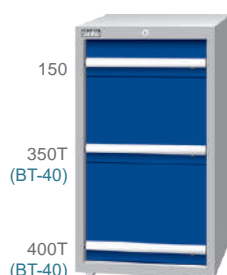

EA-10031-22N W566xD607xH1000
EB-10031-22N W718xD607xH1000
ED-10031-22N W718xD759xH1000

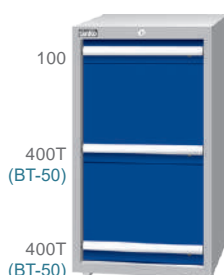

EA-10032-33N W566xD607xH1000
EB-10032-33N W718xD607xH1000
ED-10032-33N W718xD759xH1000



EA-12031-222N W566xD607xH1200
EB-12031-222N W718xD607xH1200
ED-12031-222N W718xD759xH1200

CNC Tool Cabinet







Adjustable frame



Handle with lock





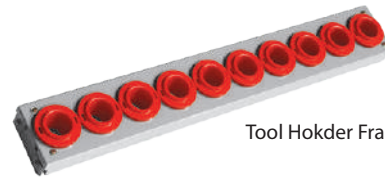

Tool Holder Frame		
Type	Holders Spec	Holders Qty
ENP-61	BT-30 	10 pcs
ENP-62	BT-40 	10 pcs
ENP-63	BT-50 	7 pcs
ENP-66	HSK-40 	10 pcs
ENP-68	HSK-63 	7 pcs

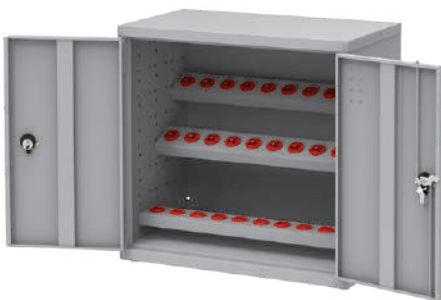





Tool Holder Frame



CNC Tool Cabinet H900		
Type	Holders Spec	Holders Qty
SAN-331	BT-30 	30 pcs
SAN-332	BT-40 	30 pcs
SAN-333	BT-50 	21 pcs
SAN-336	HSK-40 	30 pcs
SAN-338	HSK-63 	21 pcs

W900 x D515 x H900

5 types of optional tool holders
With 3 tool holder frames

CNC Tool Cabinet H1780		
Type	Holders Spec	Holders Qty
SAN-361	BT-30 	60 pcs
SAN-362	BT-40 	60 pcs
SAN-363	BT-50 	42 pcs
SAN-366	HSK-40 	60 pcs
SAN-368	HSK-63 	42 pcs

W900 x D515 x H1780

5 types of optional tool holders
With 6 tool holder frames

ENS-1 CNC Trolley

PATENTED

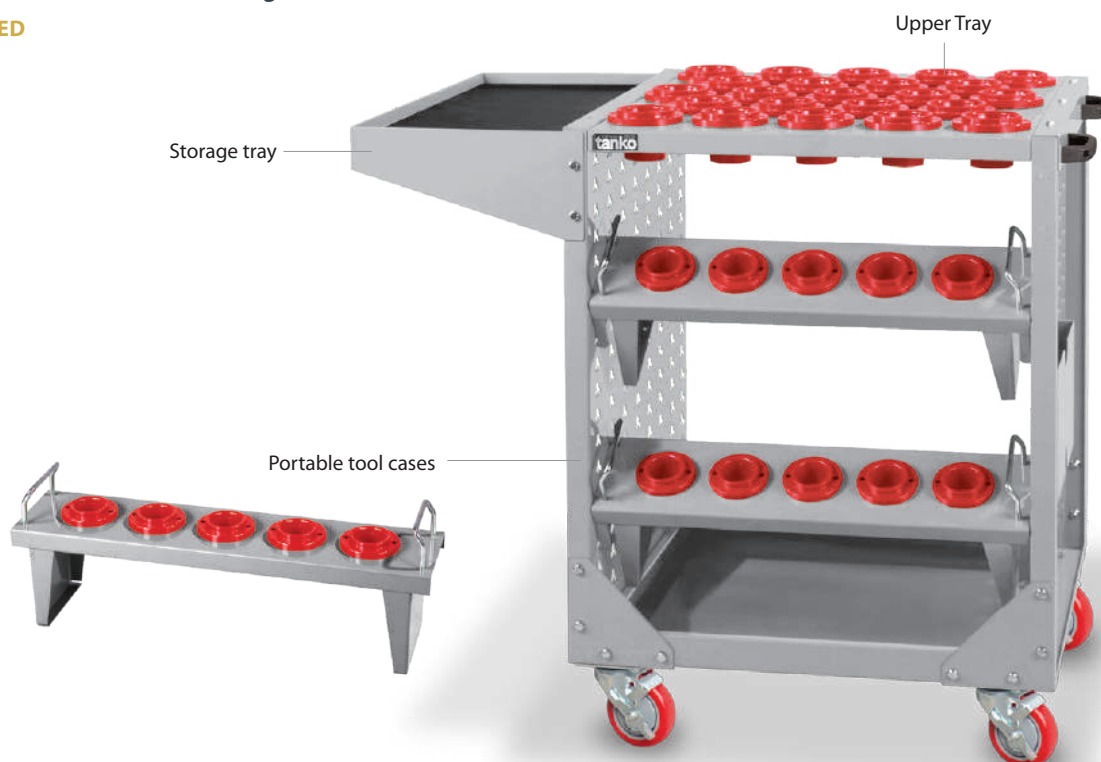

400kg load capacity



A4 document holder



Portable tool cases work with perforated side boards facilitates the adjustment of position and angle.



4"PU casters

CNC Trolley		
Type	Holders Spec	Holders Qty
ENS-112M	BT-30	45 pcs
ENS-122M	BT-40	43 pcs
ENS-132M	BT-50	31 pcs
ENS-162M	HSK-40	45 pcs
ENS-182M	HSK-63	31 pcs

W1030 x D656 x H911

Portable Tool Cases		
Type	Holders Spec	Holders Qty
ENP-11	BT-30	6 pcs
ENP-12	BT-40	5 pcs
ENP-13	BT-50	4 pcs
ENP-16	HSK-40	6 pcs
ENP-18	HSK-63	4 pcs

W602 x D142 x H165

5 types of optional tool holders
Total holders = upper tray + 2 sets of portable tool cases

ENS-3 CNC Trolley

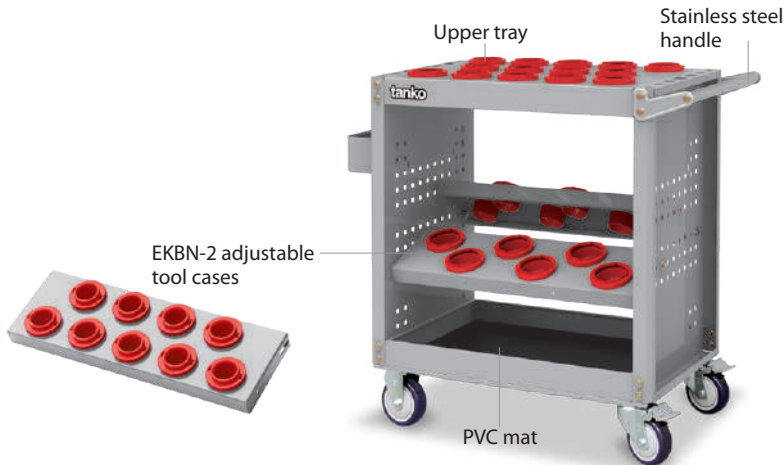

400kg load capacity



Side tray

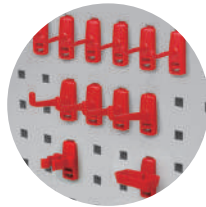

Hooks can be applied to perforated boards.
Refer to P41~P43



4" PU casters

CNC Trolley			
Type	Holder Spec		Holder Qty
ENS-312M	BT-30		51 pcs
ENS-322M	BT-40		36 pcs
ENS-332M	BT-50		26 pcs
ENS-362M	HSK-40		51 pcs
ENS-382M	HSK-63		26 pcs

W947 x D485 x H876

5 types of optional tool holders
Total holders = upper tray + 2 sets of tool cases

Adjustable Tool Cases			
Type	Holder Spec		Holder Qty
EKBN-21	BT-30		9 pcs
EKBN-22	BT-40		9 pcs
EKBN-23	BT-50		6 pcs
EKBN-26	HSK-40		9 pcs
EKBN-28	HSK-63		6 pcs

W659 x D195 x H52

ENR CNC Trolley

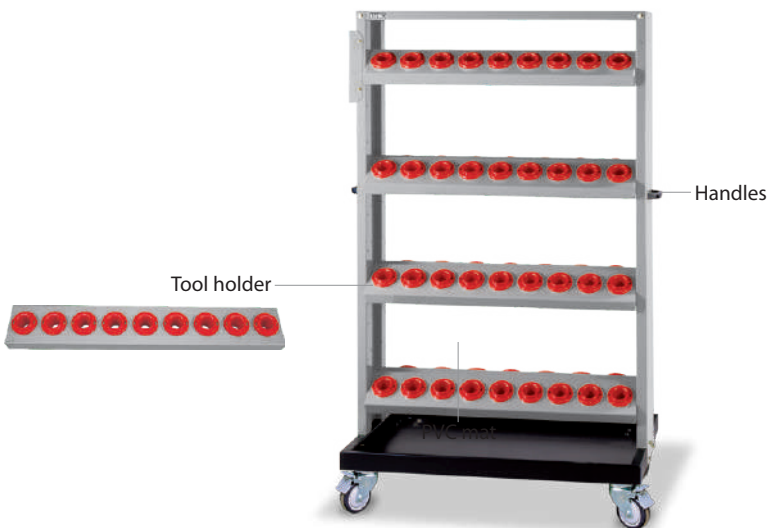

400kg load capacity



A4 document holder



Bottom tray



4" PU casters

CNC Trolley			
Type	Holder Spec		Holder Qty
ENR-1218M	BT-30		80 pcs
ENR-1228M	BT-40		72 pcs
ENR-1238M	BT-50		56 pcs
ENR-1268M	HSK-40		80 pcs
ENR-1288M	HSK-63		64 pcs

W1047 x D613 x H1585

5 types of optional tool holders
Total holders = 8 tool holder frames

Tool Holder			
Type	Holder Spec		Holder Qty
ENP-21	BT-30		10 pcs
ENP-22	BT-40		9 pcs
ENP-23	BT-50		7 pcs
ENP-26	HSK-40		10 pcs
ENP-28	HSK-63		8 pcs

W893 x D142 x H45



Top shelf is reversible for a flat surface



Side tray



Shelf can be adjusted



4"PU casters, 400kg load capacity



 **DIY Product**

EKA-3MS

W900xD485xH847

KPQ-B x 1 set



 **DIY Product**

EKA-301MS

W900xD485xH847

Drawer x 1 set
KPQ-B x 1 set



 **DIY Product**

EKA-302MS

W900xD485xH847

Drawer x 2 set
KPQ-B x 1 set



EKA-305MS

W900xD485xH847

Drawer x 5 set
KPQ-B x 1 set

EKA Trolley



400kg load capacity



Side tray



Hooks can be applied to perforated boards.
Refer to P41~P43

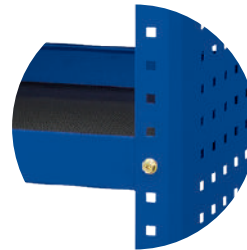

Shelf can be adjusted



Stainless steel handle



EKA-3M

W900xD485xH847

KPQ-B x 1 set



EKA-P03

W709xD452xH68

Top Cover for EKA-3M trolley

EKB Trolley



Top Cover for EKB trolley



EKB-P03

W643xD437xH60



EKB Drawer Accessory



EKB-P02

W658xD445xH45

TB-1016 drawer x 8
Shelf x 1

 400kg load capacity



Drawers can be placed upon the trolley



Stainless steel handle



Specially designed to prevent accidental slip off

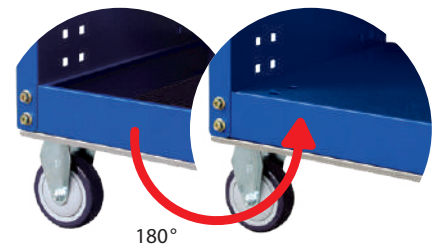

180°

Flip over to install drawers



EKB-3M

W850xD485xH853

KPQ-B x 1set



EKB-308M

W850xD485xH853

TB-1016 drawer x 8
Shelf x 1

KPQ-B x 1set



EKB-316M

W850xD485xH853

TB-1016 drawer x 16
Shelf x 2

KPQ-B x 1set

Tilt Out Bins Cart



4"x2"PU casters



PC material with transparent drawers.
Refer to P49



Shelves are optional



Bottom tray

KG 400kg load capacity

Pro



Tilt out bins (Qty)				
Type	S	M	L	
EKC-333M	144	—	—	
EKC-332M	96	32	—	
EKC-331M	96	—	16	
EKC-322M	48	64	—	
EKC-321M	48	32	16	
EKC-311M	48	—	32	
EKC-222M	—	96	—	
EKC-221M	—	64	16	
EKC-211M	—	32	32	
EKC-111M	—	—	48	

W786xD570xH1640

Standard



Tilt out bins (Qty)				
Type	S	M	L	
EKC-330M	96	—	—	
EKC-320M	48	32	—	
EKC-310M	48	—	16	
EKC-220M	—	64	—	
EKC-210M	—	32	16	
EKC-110M	—	—	32	

W786xD570xH1640
Bottom tray : W580xD530

Standard

With shelves



Standard

With a row of hanger cases



Standard

With 3 rows of hanger cases



Shelf EKC-P02

W630xD230xH40
Loading : 50kg

Hanger case (Single-sided)

	Type	Qty	Case Hanger Qty
1 row	TKI-861	6 pcs	1 pc
	TKI-8304	4 pcs	1 pc
	TKI-8305	4 pcs	1 pc
	TA-115	4 pcs	1 pc
3 row	TKI-8301	6 pcs/row	3 pcs
	TKI-8302	6 pcs/row	3 pcs
	TKI-8303	6 pcs/row	3 pcs
	TA-112	5 pcs/row	3 pcs

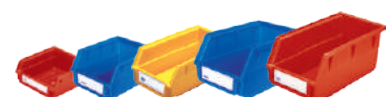

Hanger Case Refer to P51

Unit of Measurement : mm



Features ▼



Adjustable shelves



Safety pin



Ball rollers shelf provides smooth movement.

Specification ▼

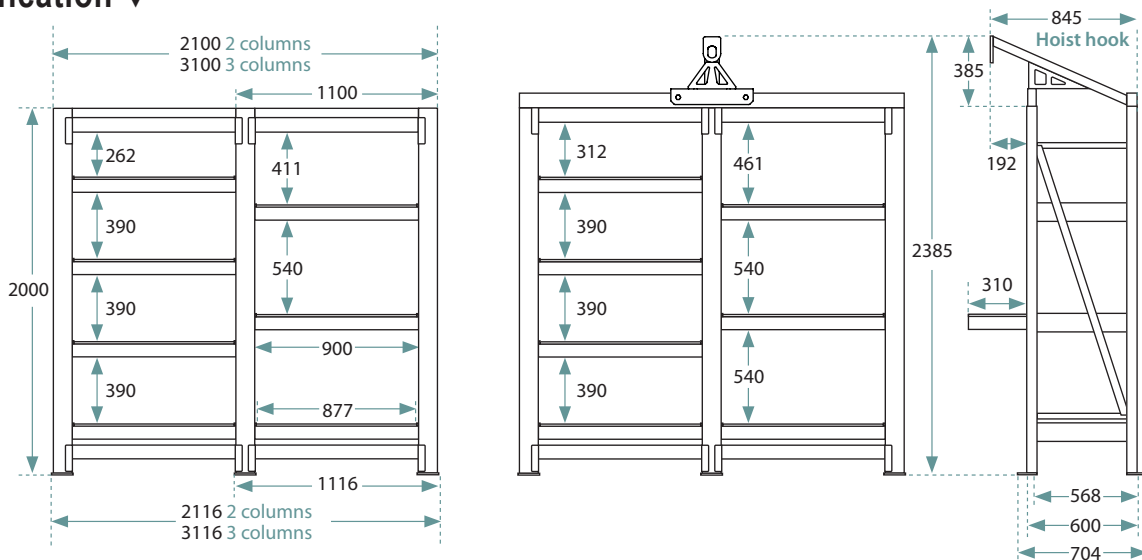

MB-206

W2116xD704xH2000

Columns : 2
Pull-out shelf quantity : 6



MB-208

W2116xD704xH2000

Columns : 2
Pull-out shelf quantity : 8



MB-309

W3116xD704xH2000

Columns : 3
Pull-out shelf quantity : 9



MB-312

W3116xD704xH2000

Columns : 3
Pull-out shelf quantity : 12



MB-2061

W2116xD845xH2385

Columns : 2
Pull-out shelf quantity : 6

Hoist rail included



MB-2081

W2116xD845xH2385

Columns : 2
Pull-out shelf quantity : 8

Hoist rail included



MB-3091

W3116xD845xH2385

Columns : 3
Pull-out shelf quantity : 9

Hoist rail included



MB-3121

W3116xD845xH2385

Columns : 3
Pull-out shelf quantity : 12

Hoist rail included

KG 1000kg per shelf

KG Hoist hook loading capacity : 500kg

Unit of Measurement : mm



Hanger Rack



Perforated board can be used with all Tanko hangers.
Refer to P41~P43

With levelers screws



Shelves are optional



Adjustable divider 100% extension



Bottom tray

KG 45kg per drawer



DA-31

W1013xD496xH1663

Drawer Divider : 2pcs each



DA-32

W1013xD496xH1663

Drawer Divider : 2pcs each



DB-31

W1013xD496xH1663

Drawer Divider : 2pcs each



DB-32

W1013xD496xH1663

Drawer Divider : 2pcs each



DE-31

W1013xD501xH1663

Bins : 20 pcs
Drawer Divider : 2pcs each



DE-32

W1013xD501xH1663

Bins : 20 pcs
Drawer Divider : 2pcs each



DP-01A DB Shelf

W996xD316xH41

Shelf Loading : 50kg

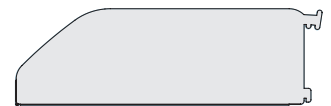

DP-01B DE Shelf

W996xD416xH41

Shelf Loading : 50kg



Bins

TE-421

Outer size
W182xD424xH136

Inner size
W140xD375xH135



PU casters with total
400kg load capacity

With
 levelers screws



KP-17 shelf is
 optional.
 Refer to P43

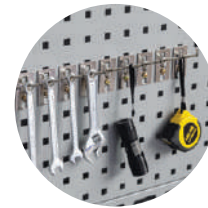

Hooks can be
 applied
 to perforated boards.
 Refer to P41~P43



Hanger case can
 be applied
 to louvred boards.
 Refer to P51



Specification ▼

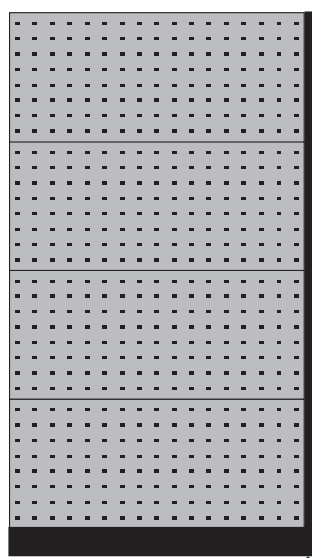
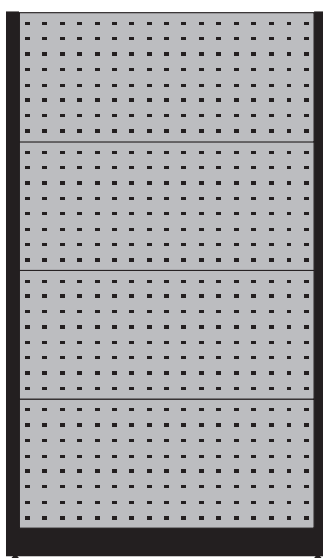

R : Independent Type **2** : 2 boards / side
L : Linkable Type **3** : 3 boards / side
M : Movable Type **4** : 4 boards / side

K R - 1 4 4 0

1 : Single-sided
2 : Double-sided

of Louvred
 Board

of Perforated
 Board

Independent Type / Linkable Type

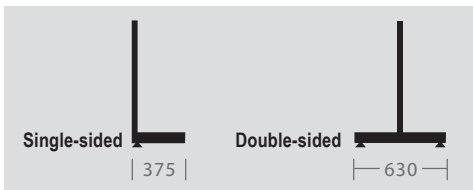
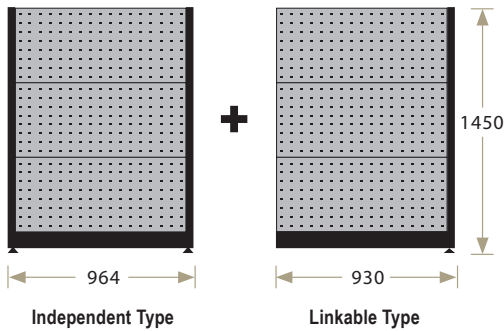

Single-sided

Independent type	KR-1303	KR-1312	KR-1321	KR-1330
Linkable Type	KL-1303	KL-1312	KL-1321	KL-1330
Perforated Board (Qty)	—	1	2	3
Louvred Board (Qty)	3	2	1	—
Color	●	●	●	○ ● ● ● ●

Double-sided

Independent type	KR-2306	KR-2324	KR-2342	KR-2360
Linkable Type	KL-2306	KL-2324	KL-2342	KL-2360
Perforated Board (Qty)	—	2	4	6
Louvred Board (Qty)	6	4	2	—
Color	●	●	●	○ ● ● ● ●

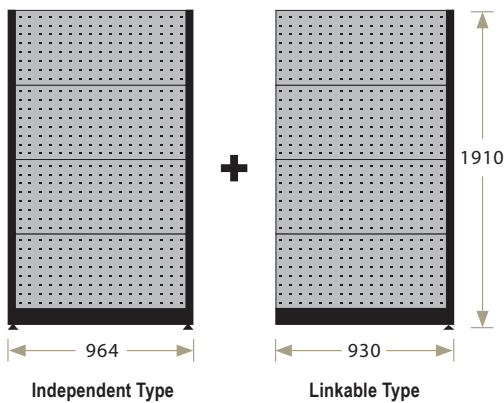

Single-sided

Independent type	KR-1404	KR-1413	KR-1422	KR-1431	KR-1440
Linkable Type	KL-1404	KL-1413	KL-1422	KL-1431	KL-1440
Perforated Board (Qty)	—	1	2	3	4
Louvred Board (Qty)	4	3	2	1	—
Color	●	●	●	●	○ ● ● ● ●

Double-sided

Independent type	KR-2408	KR-2426	KR-2444	KR-2462	KR-2480
Linkable Type	KL-2408	KL-2426	KL-2444	KL-2462	KL-2480
Perforated Board (Qty)	—	2	4	6	8
Louvred Board (Qty)	8	6	4	2	—
Color	●	●	●	●	○ ● ● ● ●

Movable Type

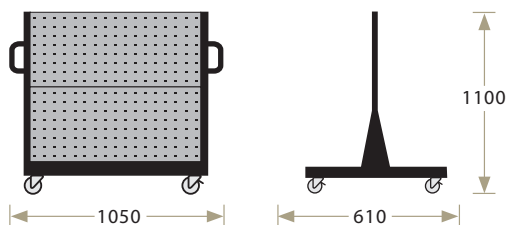

Double-sided

Type	KM-2204	KM-2222	KM-2240
Perforated Board (Qty)	—	2	4
Louvred Board (Qty)	4	2	—
Color	●	●	○ ● ● ● ●

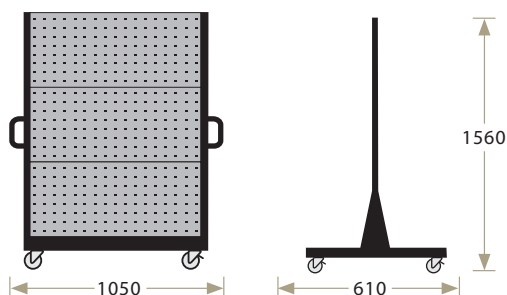

Double-sided

Type	KM-2306	KM-2324	KM-2342	KM-2360
Perforated Board (Qty)	—	2	4	6
Louvred Board (Qty)	6	4	2	—
Color	●	●	●	○ ● ● ● ●

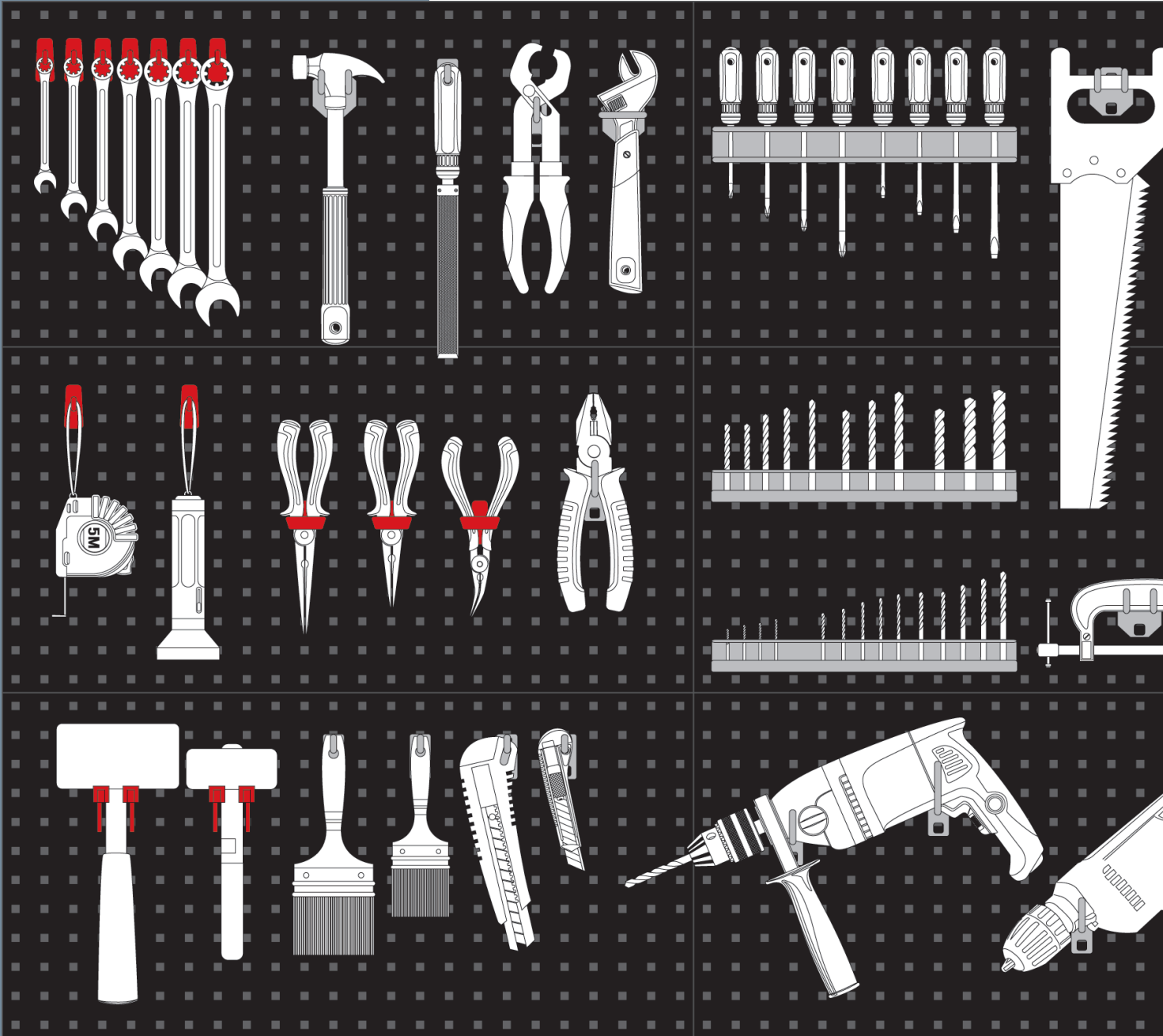

Perforated Board

Perforated Board

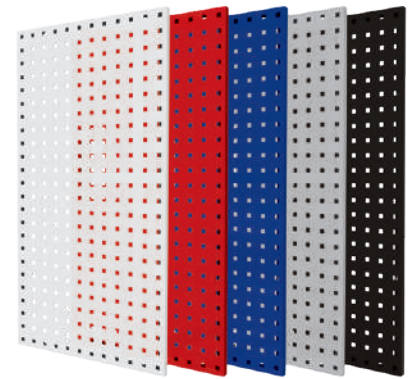
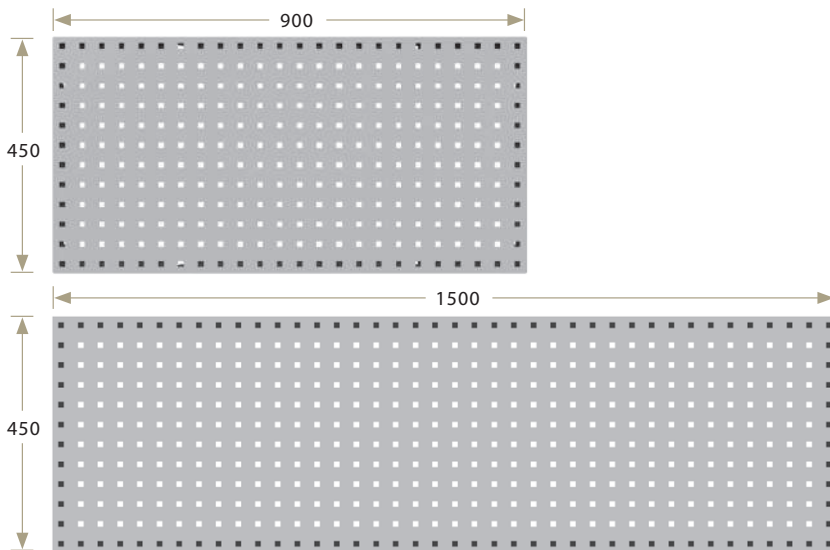

KQ-306A	KQ-310
W900xH450	W1500xH450
○ ● ● ● ● ● ● ●	●

Can be installed onto wall, and be used with all Tanko hangers. P41~P43

Louvred Board

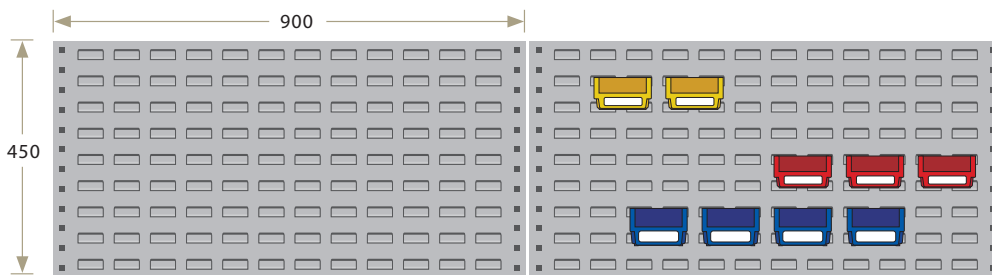

KH-306
W900xH450
●

Can be installed onto wall, and be used with hanger bins. P51

Stainless Steel Hooks

PATENTED 5kg load capacity



Stainless steel

V Hook

KP-7203
L30
○ ● ● ● ● ● ● ●
10 pcs



L Hook

KP-7108
L80
○ ● ● ● ● ● ● ●
10 pcs



Closed End Loop Hook

KP-7604
W40xD30
○ ● ● ● ● ● ● ●
10 pcs



S-Loop Hook

KP-7502
Ø20
○ ● ● ● ● ● ● ●
10 pcs



Closed End Loop Hook

KP-7308
W80xD40xH40
○ ● ● ● ● ● ● ●
10 pcs



M-Loop Hook

KP-7506
Ø60
○ ● ● ● ● ● ● ●
10 pcs



L-Loop Hook

KP-7510
Ø100
○ ● ● ● ● ● ● ●
10 pcs

Perforated Board Accessories

Plastic Hooks



S-single Hook

KP-6101

W17xD55xH52

20 pcs
2kg load capacity



M-single Hook

KP-6102

W17xD75xH52

10 pcs
2kg load capacity



U-shape Hook

KP-6103

W46xD48xH52

6 pcs
2kg load capacity



Spring Clips

KP-6104

W25xD55xH52

10 pcs
2kg load capacity



Hooks Set

KPQ-B

KP-6101 x 6 pcs
KP-6102 x 4 pcs
KP-6103 x 1 pc
KP-6104 x 1 pc



Wrench Holder

KP-6109

W120xH220

1 pc

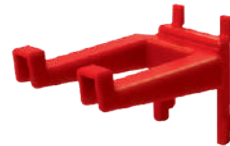

Double Hook

KP-6208

W65xD105xH60

10 pcs
4kg load capacity



Suspension Hook

KP-6308

W50xD100xH60

10 pcs
4kg load capacity

Metal Hooks



Suspension Hook

KP-3305

L50

10 pcs
6kg load capacity



Double Hook

KP-3405

L50

10 pcs
6kg load capacity



Suspension Hook

KP-3108 L80

KP-3112 L120

KP-3116 L160

6kg load capacity 10 pcs

KP-3130 L300

3kg load capacity

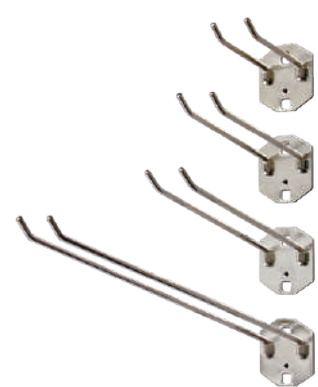

Double Hook

KP-3208 L80

KP-3212 L120

KP-3216 L160

6kg load capacity 10 pcs

KP-3230 L300

3kg load capacity



Loop Hook

KP-3502

Ø20

KP-3503

Ø30



KP-3506

Ø60

KP-3510

Ø100

10 pcs
6kg load capacity



U-shape Hook

KP-3805

L50

KP-3810

L100

10 pcs
6kg load capacity



Semicircle Hook

KP-3705

L50

KP-3709

L90

10 pcs
6kg load capacity

Hangers



Drill Holder

KP-4120
L390
20 holes : Ø5x8 . Ø8x7 . Ø13x5
1 pc



Drill Holder

KP-4114
L390
14 holes : Ø14x6 . Ø19x4 . Ø22x4
1 pc

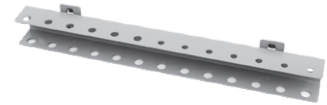

Screwdriver Holder

KP-4213
L390
13 holes : Ø8x7 . Ø10x6
1 pc



Clip Holder

KP-4418
L430
18 clips
1 pc



T Handle Holder

KP-4504
W88xD110xH62
4 T handles
1 pc

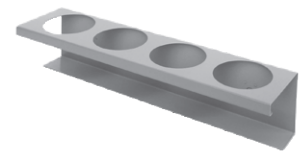

Bottle Holder

KP-4604
W390xD90xH85
4 bottles
1 pc



Hanger Case

KPQ-4301	KPQ-4302	KPQ-4304
	L420	
TKI-8301 x 4 W105xD110xH50	TKI-8302x4 W105xD140xH75	TKI-8304x3 W140xD220xH124
	1 set	



Hanger Case

KPQ-4306	KPQ-4307
L456	L608
TK-8722x2 . TK-8723x2	TK-8722x2 . TK-8723x3
TK-8722:W148xD74xH45 . TK-8723:W148xD148xH45	
	1 set

Hanger Case Refer to P51



Bin Hanger

KP-4300
12 pcs

Suitable for all Tanko hanger case

Hanger Case Refer to P50~51



TA-112 TA-115 TKI-861 TKI-8301 TKI-8302 TKI-8303 TKI-8304 TKI-8305



Shelf

KP-17
W900xD300
1 Set





Documents & Parts Cabinet / Bin

Documents Cabinet



Colored Label

A4L	A4M
	
Outer size:W257xD346xH78 Inner size:W251xD327xH72	Outer size:W257xD346xH52 Inner size:W251xD327xH46
PS	



A4L-104
W284xD348xH360
Drawer : A4L x 4



A4LM-10203
W284xD348xH360
Drawer : A4L x 2
A4M x 3



A4L-204P
W586xD348xH380
Drawer : A4L x 4



A4M-212
W586xD348xH380
Drawer : A4M x 12



A4L-220
W596xD348xH880
Drawer : A4L x 20



A4L-330
W880xD348xH880
Drawer : A4L x 30



A4M-345
W880xD348xH880
Drawer : A4M x 45



A4LM-32418
W880xD348xH1060
Drawer : A4L x 24
A4M x 18







A4L-330D
W940xD405xH945
Drawer : A4L x 30
Handle with lock



A4M-345D
W940xD405xH945
Drawer : A4M x 45
Handle with lock





Parts Cabinet

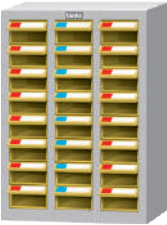

TKI Parts Cabinet

TKI-1	TKI-1-1	TKI-1-2	TKI-2	TKI-2-1
				
PS+ABS	ABS	PS	PS	ABS
Outer size:W120xD240xH70 Inner size:W114xD212xH65			Outer size:W100xD220xH52 Inner size:W95xD195xH47	
10kg load capacity	10kg load capacity	6kg load capacity	5kg load capacity	10kg load capacity

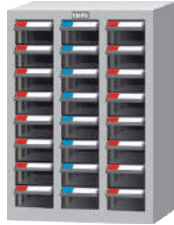

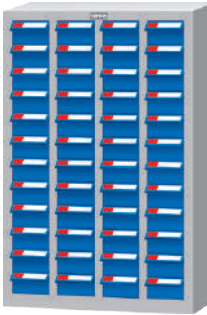
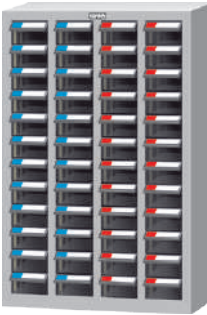
Each drawer includes one divider.
PS drawers are not suitable for oily items

					
TKI-1308	TKI-1308-1	TKI-1308-2	TKI-1412	TKI-1412-1	TKI-1412-2
Drawer:TKI-1 x 24	Drawer:TKI-1-1 x 24	Drawer:TKI-1-2 x 24	Drawer:TKI-1 x 48	Drawer:TKI-1-1 x 48	Drawer:TKI-1-2 x 48
W450xD242xH650			W600xD242xH940		

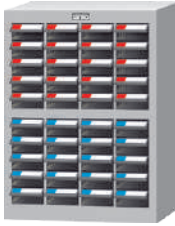
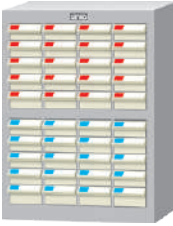
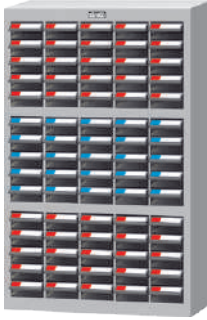
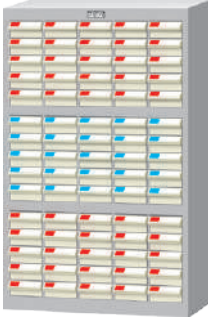
					
TKI-2405	TKI-2405-1	TKI-2410	TKI-2410-1	TKI-2515	TKI-2515-1
Drawer:TKI-2 x 20	Drawer:TKI-2-1 x 20	Drawer:TKI-2 x 40	Drawer:TKI-2-1 x 40	Drawer:TKI-2 x 75	Drawer:TKI-2-1 x 75
W460xD230xH310		W475xD230xH650		W580xD230xH940	

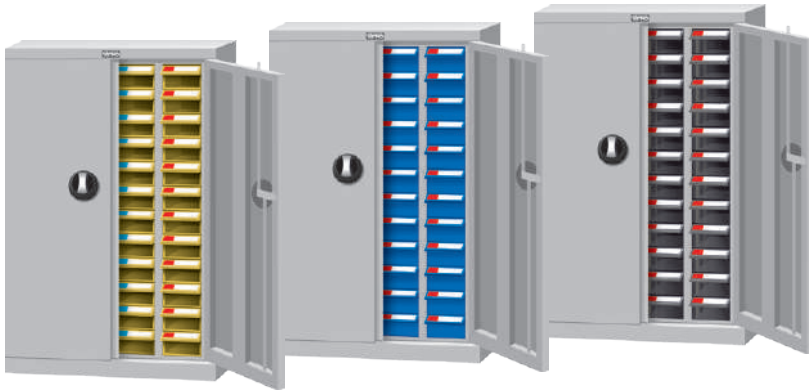

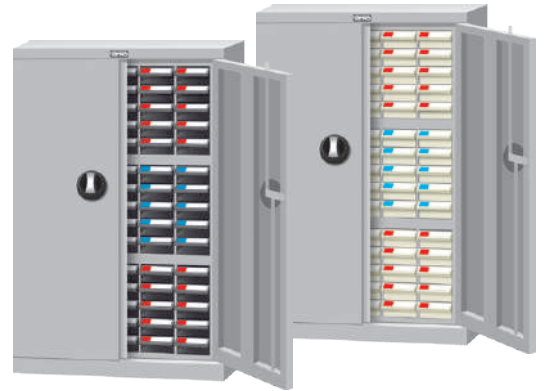

TKI-1412D	TKI-1412D-1	TKI-1412D-2
Drawer:TKI-1 x 48 Handle with lock	Drawer:TKI-1-1 x 48 Handle with lock	Drawer:TKI-1-2 x 48 Handle with lock
W645xD295xH1000		



TKI-2515D	TKI-2515D-1
Drawer:TKI-2 x 75 Handle with lock	Drawer:TKI-2-1 x 75 Handle with lock
W645xD295xH1000	

CEA/CEH Parts Cabinet

CEA	CEH
	
PS+ABS	
Outer size:W164xD282xH76 Inner size:W158xD252xH71	Outer size:W120xD238xH70 Inner size:W114xD212xH65
10kg load capacity	



Each drawer includes one divider.



CEA-324	CEA-330	CEA-330D
Drawer : CEA x 24	Drawer : CEA x 30	Drawer : CEA x 30 Handle with lock
W600xD283xH720	W600xD283xH880	W640xD340xH925



CEH-324	CEH-448	CEH-448D
Drawer : CEH x 24	Drawer : CEH x 48	Drawer : CEH x 48 Handle with lock
W450xD240xH650	W600xD240xH940	W645xD295xH1000

Parts Cabinet

RB Parts Cabinet

 PATENTED



TB-1016

PP+PS

Outer size:W160xD450xH117
Inner size:W127xD392xH98

10kg load capacity

Each drawer includes one divider.



RB-530

Drawer : TB-1016 x 30

W900xD500xH900



RB-565

Drawer : TB-1016 x 65

W900xD500xH1800

RM Parts Cabinet



TR-4116

ABS+PS

Outer size:W168xD415xH105
Inner size:W142xD373xH97

10kg load capacity

Each drawer includes one divider.

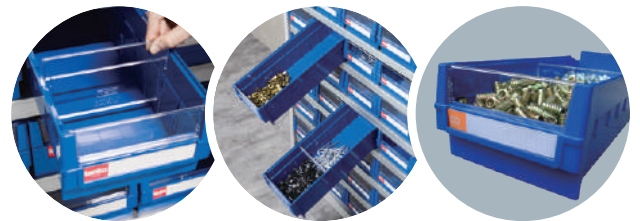

RM-309

Drawer : TR-4116 x 9

W560xD420xH468



RM-515

Drawer : TR-4116 x 15

W900xD420xH468



RM-318

Drawer : TR-4116 x 18

W560xD420xH880

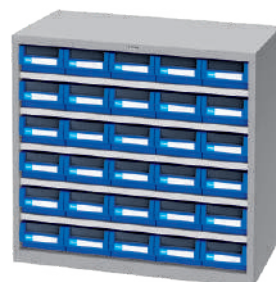

RM-530

Drawer : TR-4116 x 30

W900xD420xH880

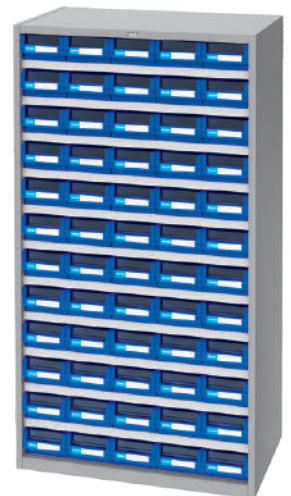

RM-560

Drawer : TR-4116 x 60

W900xD420xH1760

Tilt Out Bin



PC bins are suitable for oily items. 50° tilt out angle.



Can be applied to perforated boards with optional clips.



Bins are removable for easy access, refilling, and cleaning.



L

TC-111

W300xD98xH112.5

Drawer : W280xD65xH70 (1.2L)

5kg load capacity

3 pcs / CTN
with colored label



M

TC-112

W300xD98xH112.5

Drawer : W130xD65xH70 (0.6L)

3kg load capacity

3 pcs / CTN
with colored label



S

TC-113

W300xD98xH112.5

Drawer : W85xD65xH70 (0.4L)

2kg load capacity

3 pcs / CTN
with colored label

Team Case

PS drawers are not suitable for oily items

Assembly step 1.

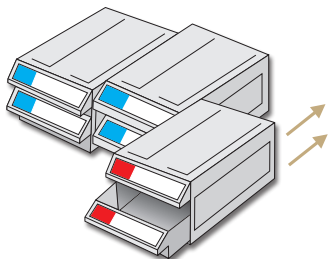

Assembly step 2.

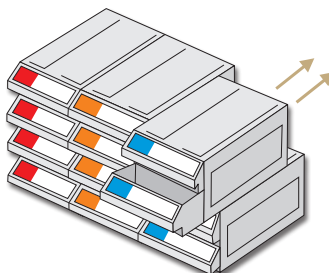

TKI-301

Outer Size : W128xD195xH86

Drawer : W116xD167xH73

12 pcs / CTN
with colored label



TKI-302

Outer Size : W128xD195xH86

Drawer : W116xD167xH35

12 pcs / CTN
with colored label



TKI-304

Outer Size : W128xD195xH86

Drawer : W53xD167xH35

12 pcs / CTN
with colored label

TA Team Bin



Streamline shape

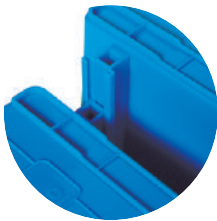

Side Link Slots



Supporting Poles



Colored Label



Hanger Function



TA-112

Outer size : W123xD180xH77
Inner size : W98xD145xH71

50 pcs / CTN

Supporting poles and colored label included

Has hanger function



TA-115

Outer size : W153xD250xH127
Inner size : W118xD191xH118

36 pcs / CTN

Supporting poles and colored label included

Has hanger function



TA-120

Outer size : W203xD350xH157
Inner size : W153xD276xH149

18 pcs / CTN

Supporting poles and colored label included



TA-154

Outer size : W203xD450xH180
Inner size : W148xD367xH172

12 pcs / CTN

Supporting poles and colored label included

Can be assembled with TA-155



TA-155

Outer size : W303xD450xH180
Inner size : W248xD367xH172

8 pcs / CTN

Supporting poles and colored label included

Can be assembled with TA-154

TKI Team Bin

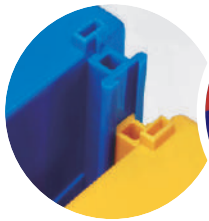

Side Link Slots

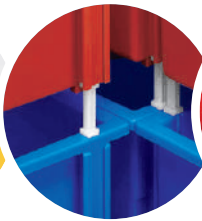

Supporting Poles



Colored Label



Hanger Function



Team Bin



Type	TKI-861	TKI-810	TKI-815	TKI-820	TKI-854	TKI-855
Outer size	W100xD170xH74	W102xD162xH74	W152xD243xH125	W202xD342xH153	W200xD450xH177	W300xD450xH177
Inner size	W72xD113xH68	W70xD117xH67	W126xD190xH118	W170xD266xH146	W158xD355xH170	W258xD355xH170
Qty	100 pcs / CTN	100 pcs / CTN	36 pcs / CTN	18 pcs / CTN	12 pcs / CTN	8 pcs / CTN
Color	● ● ●					
Acc	Supporting poles and colored label included					

Has hanger function

Hanger Case

Has hanger function



Type	TKI-8301	TKI-8302	TKI-8303	TKI-8304	TKI-8305
Outer size	W105xD110xH50	W105xD140xH75	W105xD190xH75	W140xD220xH124	W140xD270xH125
Inner size	W86xD78xH45	W86xD100xH70	W86xD150xH70	W115xD151xH118	W115xD201xH118
Load	3 kg	4 kg	4 kg	10 kg	10 kg
Qty	24 pcs / CTN	24 pcs / CTN	24 pcs / CTN	12 pcs / CTN	12 pcs / CTN
Color	● ● ● ● ●				
Acc	Supporting poles and colored label included				



Tanko Enterprise Co., Ltd.

Tel +886-905-256-188
E-mail intl@tanko.com.tw
Web www.tanko.com.tw

Taipei

No.1, Guanghua Rd., Sanchong Dist.,
New Taipei City
24158, Taiwan (R.O.C.)

Taichung

No.10, Gongyequ 2nd Rd., Xitun Dist.,
Taichung City
40767, Taiwan (R.O.C.)