

Sigma 8+

VERTICAL MC

		Sigma 8+	
Table & Travel	Table Size	mm	1000x550
	T Slot (No. x W x Pitch)	mm	5 x 18 x 100
	Max. Loading	kgs	600
	X Axis Travel	mm	850
	Y Axis Travel	mm	550
	Z Axis Travel	mm	600
	Spindle Nose to Table	mm	150-750
	Spindle center to column	mm	600
Feedrate	Rapid Feed	M/min	36 / 36 / 36
	Max. Cutting Feed	mm/min	12000
Spindle	Speed (Std.)	rpm	10,000
	Speed (Opt.)		12,000 / 15,000
	Spindle Taper		BBT40
	Power	Kw	10000rpm : 7.5 / 11 12000rpm : 7.5 / 11 15000rpm : 15 / 18
A.T.C.	Tool Shank		BT40
	Tool Capacity		24
	Max. Tool Length	mm	300
	Max. Tool Diameter	mm	80
	Max. Tool Weight	kgs	7
X/Y/Z Servo Motor	X / Y / Z	Kw	3 / 3 / 3
Positioning Accuracy		mm	0.005
Repeat Accuracy		mm	0.004
General	Width	mm	2250
	Depth	mm	2485+600 (Chip Conveyor)
	Height	mm	2750+150 (CTS)
	Machine Weight	kgs	6500

1. Please contact us for more detailed specification.
2. NUMEN owns the rights to modify the drawing and specification.

Standard

- Fanuc Oi-MF Plus Controller
- Alarm & Working Light
- 24T ARM Type ATC
- Spindle Oil Cooler
- Full Enclosed Guarding
- Heat Exchanger
- Auto Grease Lube System
- Screw Type Chip Conveyor

Option

- Tool Length Measurement System
- Coolant Through Spindle
- Laser Tool Length Measurement System
- Digital Read Out
- Probe System
- Oil Mist Collector
- Oil / Air Cutting Facility
- Chain Type Chip Conveyor

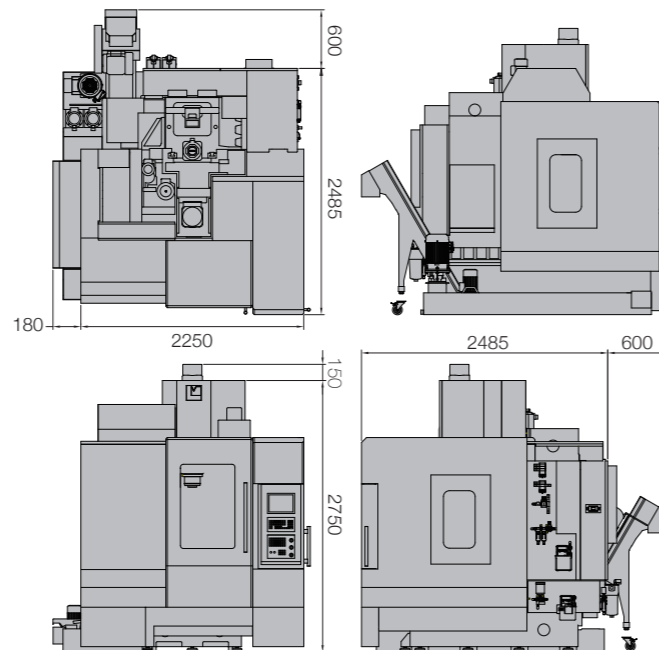

Sigma 8+

VERTICAL MC

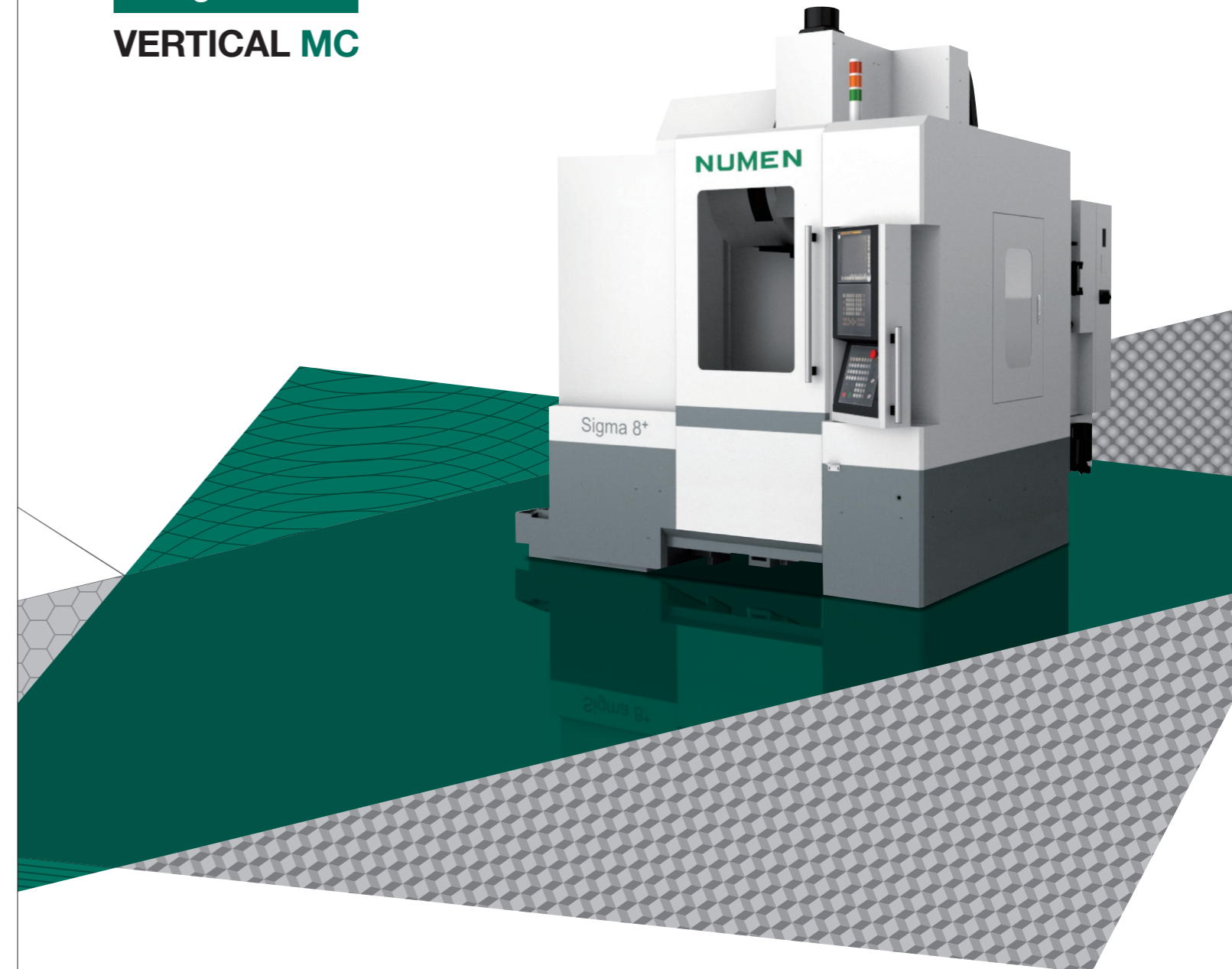

Pursuing
Customer Satisfaction
Is My Responsibility.



NUMEN
MACHINERY

NUMEN MACHINERY CO., LTD.

30, Alley 28, Lane 230, Sec. 5, Da Feng Road,
Feng Yuan Dist., Taichung City 420, Taiwan

✉ sales@numenmachinery.com.tw

🌐 numenmachinery.com.tw

☎ +886-4-2533-0966

☎ +886-4-2533-0125



VERTICAL MC

Roller Linear Slideway Blocks

X:35mm*6
Y:45mm*4
Z:45mm*6

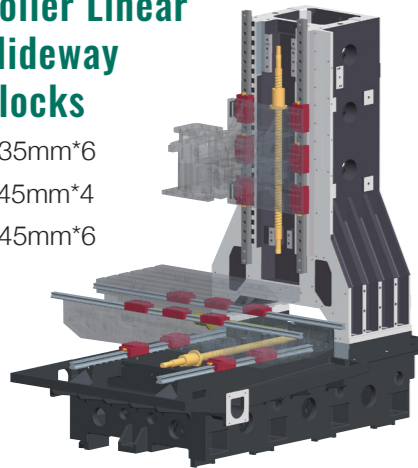

C3 Ball Screw

Dia. 40/40/40mm

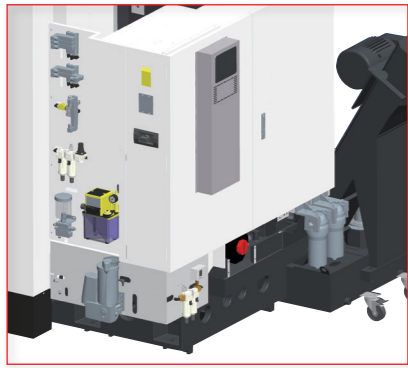

Simplified pneumatic, hydraulic, lubrication and CTS filter system easy for maintenance.

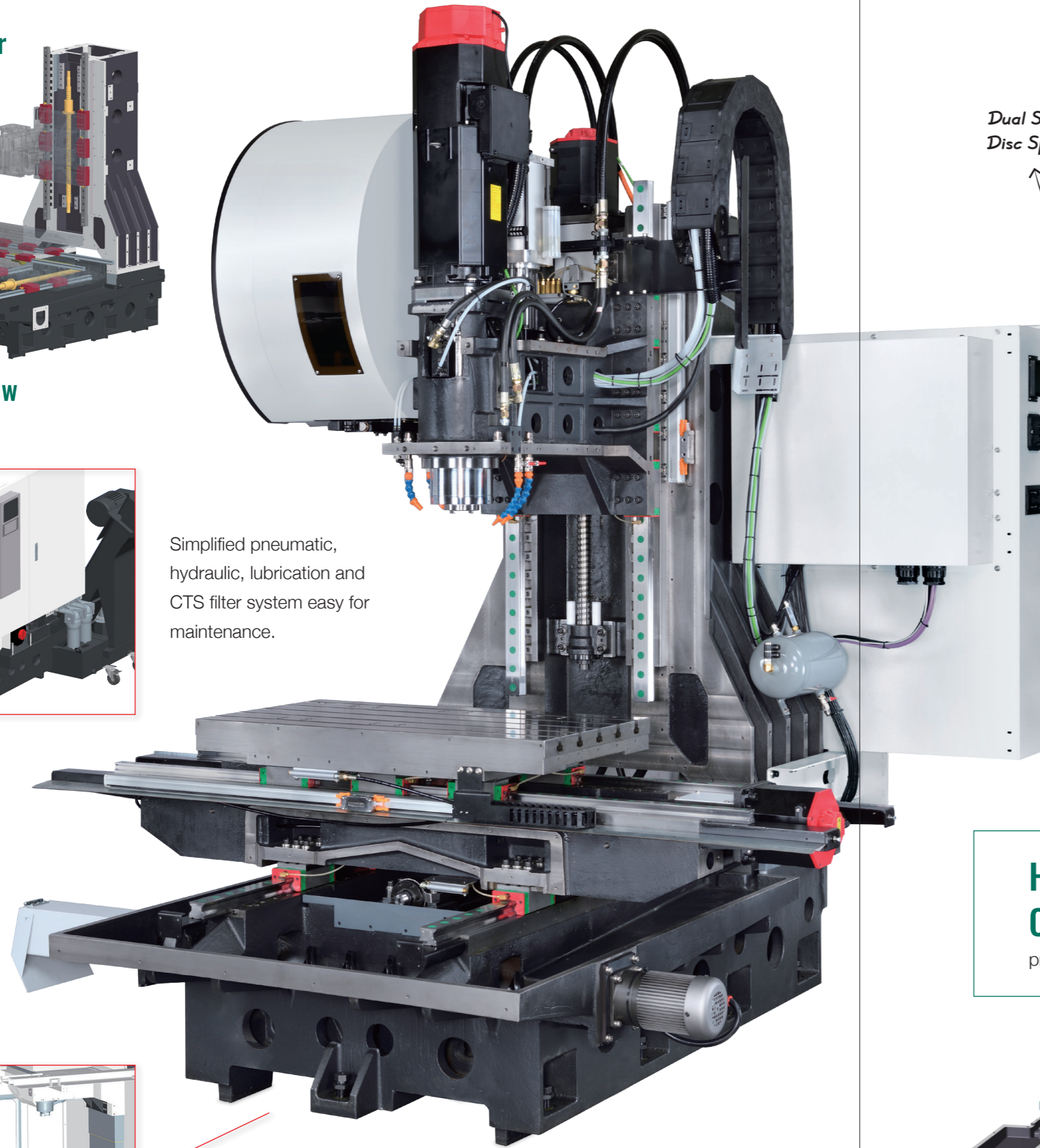

Load/Unload Workpiece

Machine base with space for hydraulic trolley to load/unload workpiece.

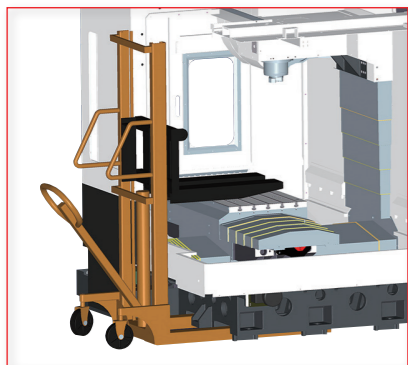

VERTICAL MC

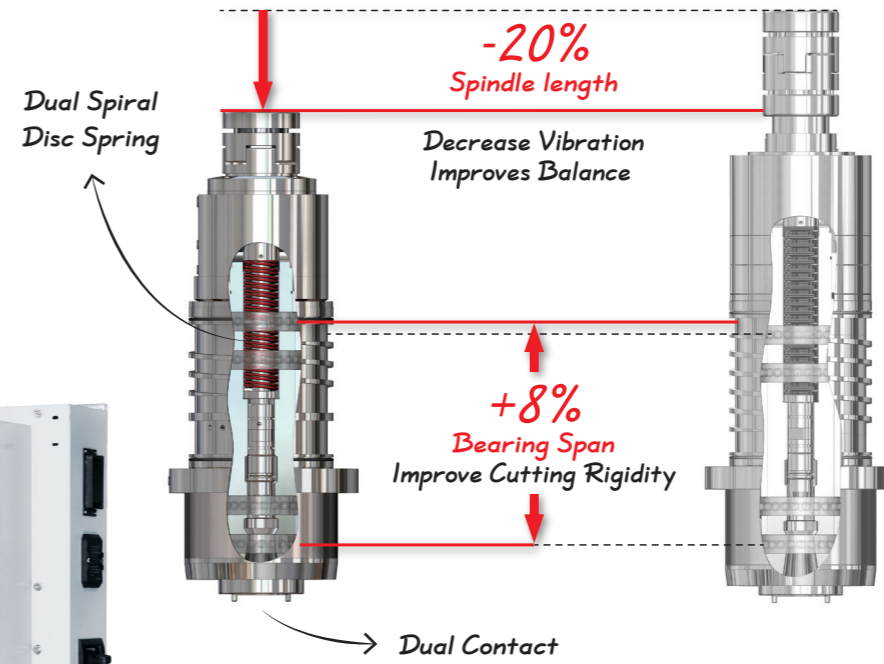

Spindle Advantage

- Spindle shorten by 20% and the bearing span lengthen by 8% compared with conventional spindles, decreases vibration and increases rigidity.
- Dual spiral disc spring shorten by 35%, which improves the dynamic balance and prolongs the life time by 80%.

- Dual contact improves heavy-duty cutting and increases the machining accuracy.
- Optimal oil/air lubrication system prolongs spindle life and reduces thermal expansion. Automatic adjustment oil/air supply to achieve energy saving.

High-pressure Chip Flushing System

provides effective chip removal

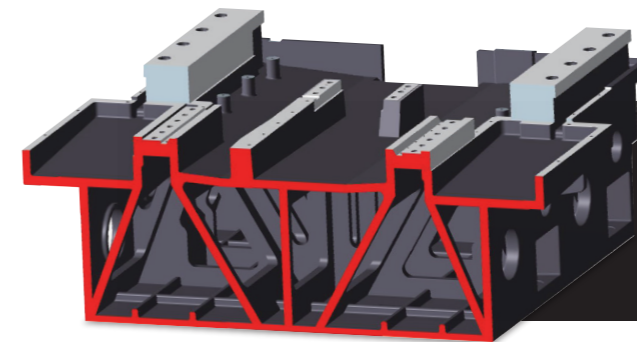
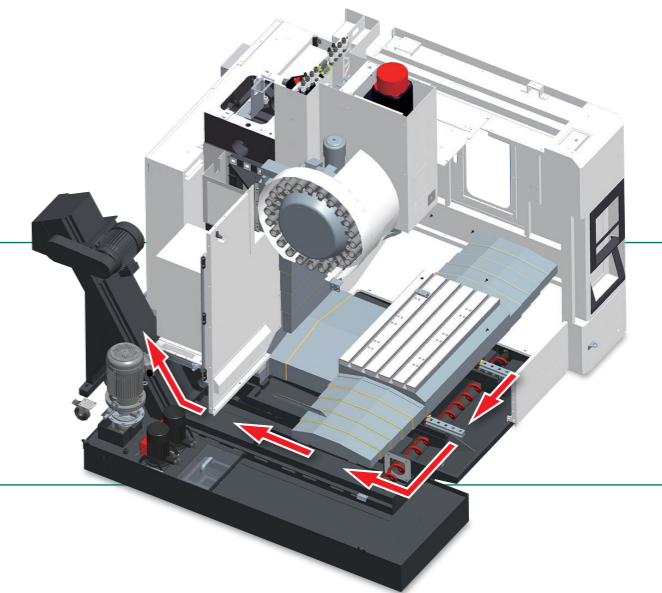

Double W base design

Z axis without counter weight, providing the best dynamic accuracy