



ANGLE HEAD

MST corporation

ANGLE HEAD **HALF**

**NEW
CONCEPT**

➔ P. 2

Optimal design for drilling and tapping.

Add one more axis at
a minimum cost.



ANGLE HEAD STANDARD type

➔ P. 9



SUPER RIGID MODEL
Ideal for end-mill application.

Custom-made products

➔ P. 14

Extensive
manufacturing
experience.

Production
starting from
just 1 unit.



MST corporation

1711

ANGLE HEAD HALF

PAT.

- Affordable 2,300USD~
- Speedy Shorter delivery
- Light-weight 1.8 kg~
- Compact $\phi 36$ ~
- Repair it yourself

Drilling and tapping account for 80% of angle head operation.

The Angle Head HALF was redesigned to achieve the necessary rigidity and accuracy, it allows;

- AFFORDABLE (Price : 1/2)
- QUICK DELIVERY (Lead Time : 1/2)
- LIGHTWEIGHT (Weight : 1/2)



90° type

HFD/HFA
 $\phi 1 \sim 20\text{mm}$

HFT
M2~16



BT30/40/50
HSK-A63
DIN40/50
CAT.40/50

mini type

Extra-compact head

HFCS
 $\phi 3, 4, 6\text{mm}$
M4, 5, 6

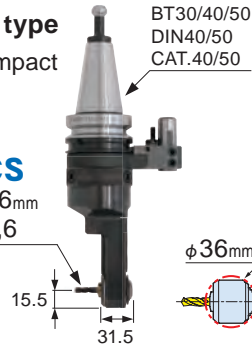

BT30/40/50
DIN40/50
CAT.40/50

UNIVERSAL type

Angle can be set arbitrarily

HUD/HUA
 $\phi 1 \sim 20\text{mm}$

HUT
M2~12

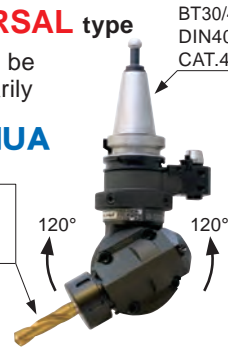

BT30/40/50
DIN40/50
CAT.40/50

Compact design

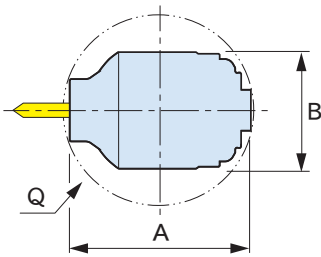

Type	CODE	Q	A	B
90° type	HFD 7	72	68	38
	HFD12	98	93	58
	HFT 4	75	73	38
	HFT 6	97	92	58
	HFA10	90	87	38
	HFA20	119	111	64
	HFT12	97	96	64
		116	115	
mini type	HFCS6	36	31.5	31

Auto Tool Changer (A.T.C) is available on BT30 machine.



BT30
1.8kg

Easy installation

The positioning pin allows an in-use positioning block to be used is now a standard feature. Can be used with a variety of machining centers.

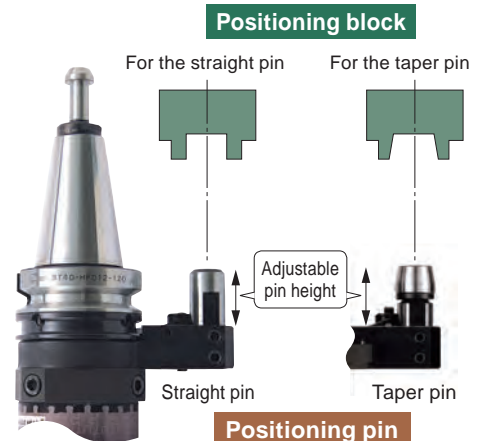

Easy disassembly and assembly

- The number of parts (22 pcs.) is half that of conventional angle heads.
- No need for fine matching and adjustment.
- Makes use of commercial items such as bearings. Affordable and readily available.
- An informative video and an instruction manual for disassembly and reassembly are provided.



Running cost is reduced by 90% as a result of reduced repair costs and machine down time.

Positioning block and positioning pin

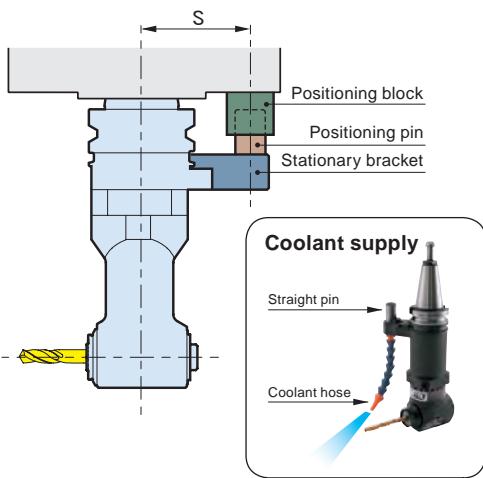

Positioning block

Positioning pin

Stationary bracket

- S dimension can be changed by reassembling the stationary bracket.
- The positioning pin can be easily adjusted in length and replaced.

Easy to reassemble

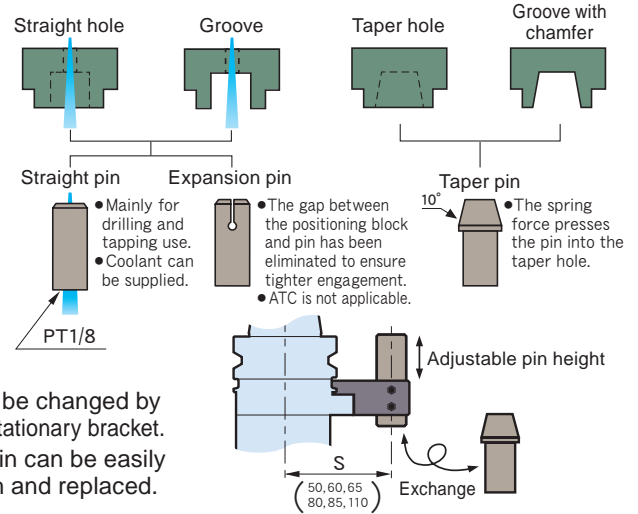
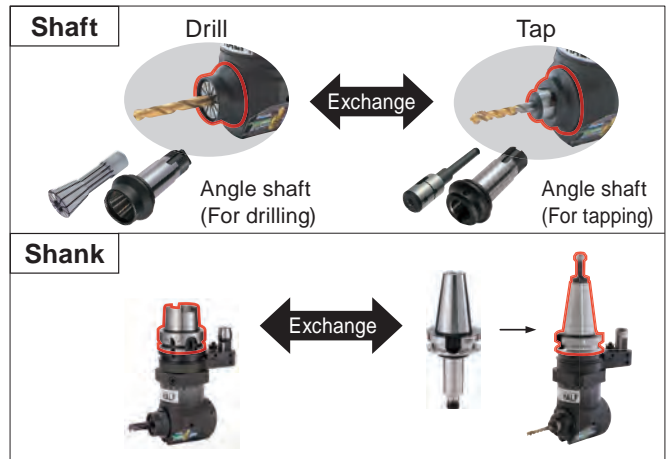

Semi-finished positioning block

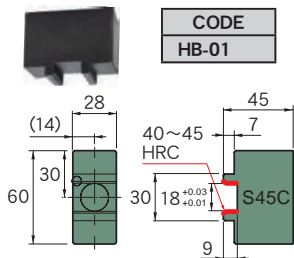

- Note**
- Please confirm with the machine tool manufacturer about the dimensions of the positioning block.
 - We have a semi-finished positioning block with a taper hole available. →P.14

Positioning block for machines

•FANUC

ROBODRILL
α-DIA series



CODE
ABF005

•MAZAK

SUPER VELOCITY CENTER
2000L/120-II 2000L/200-II



- Available from Yamazaki Mazak Corp.

•BROTHER

SPEEDIO
Tapping center



CODE	NOTE
ABF213	S300X1/S500X1/S700X1
ABF259	S1000X1
ABF176	TC-S2, S2A*, S2B, S2C, S2D, R2B*

■Caution

- TC-S2A* (Tapping center), the user needs to confirm whether the positioning block can be mounted on the machine (spindle surface) or not.
- TC-R2B* (Tapping center) machining area is limited to some extent due to interference between the positioning block and the internal part cover of the machine. For more information, please contact us.

■A product code example when ordering the Angle Head HALF.

- FANUC BT30-HFD7-122-S65
- BROTHER BT30-HFD7L-120-S50C

Kit Package

- Learning Kit to understand gear and bearing mechanism.
- There are only 22 parts and anyone can assemble them in about 10 min.
- Spare/consumable parts and assembly tools are included.



Contents of kit	CODE	
	BT40-HFD12-LK	BT50-HFD12-LK
Complete unit	BT40-HFD12-180-S65 (1 pc.)	BT50-HFD12-195-S80 (1 pc.)
Angle shaft (For tapping)	FR-T6 (1 pc.)	
Tap sleeve	TA6-3, 4, 5, 6, 8 (each 1 pc.)	
DETa-1 Collet	D12-4, 6, 8, 10, 12, 13 (each 1 pc.)	
Positioning pin	HP-50T (1 pc.)	HP-62T (1 pc.)
Spare bearing	7005ADB (1 set), 6805 (2 pcs.), 51106 (1 pc.)	

HALF 90° type

Drill · Endmill

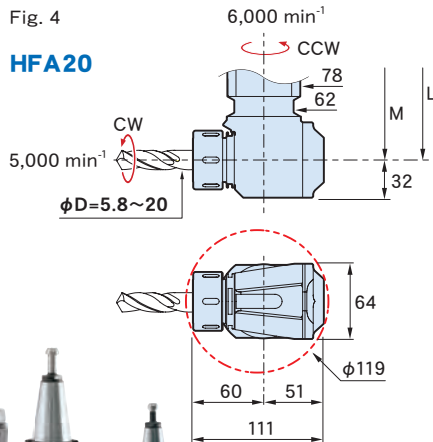
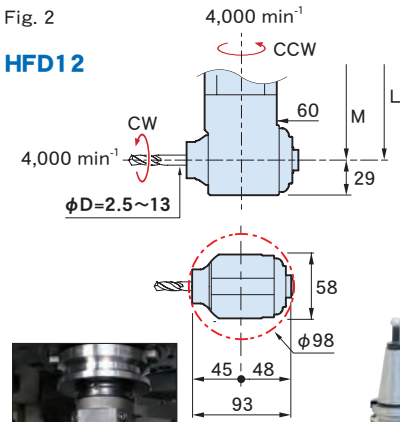
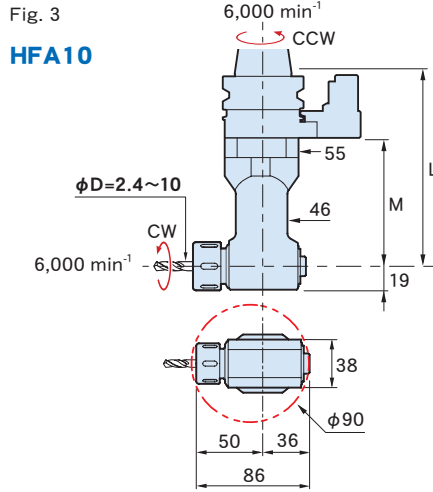
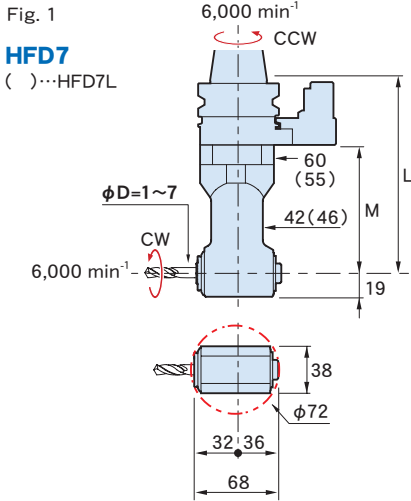

Tap

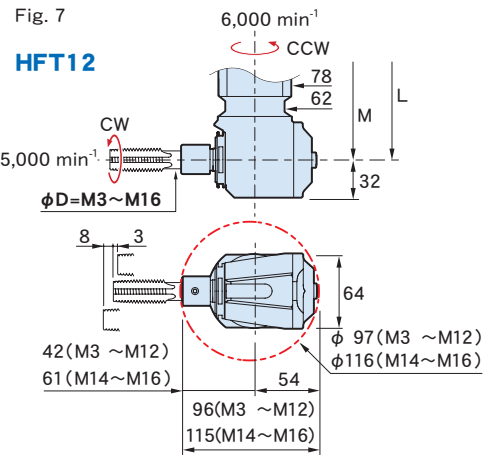
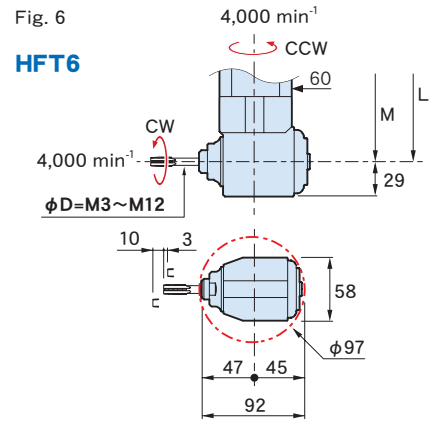
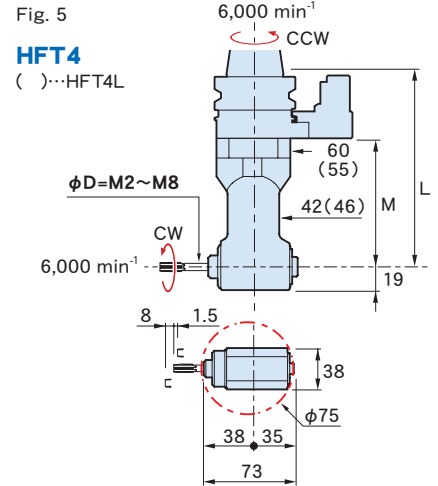

DETa-1 Collet (HFD,HUD)

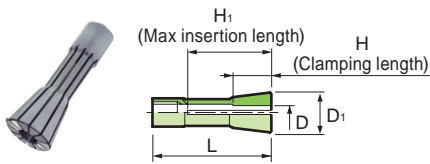

CODE	φD	φD₁	L	H	H₁	Holder type
D 7- 1.5	1 ~ 1.5	17	50	7	36	HFD 7 HUD 7
- 2	1.5 ~ 2			10		
- 2.5	2 ~ 2.5			12		
- 3	2.5 ~ 3			14		
- 4	3 ~ 4			16		
- 5	4 ~ 5					
- 6	5 ~ 6					
- 7	6 ~ 7					
D12- 4	2.5 ~ 4	26	70	16	50	HFD12
- 6	4 ~ 6			20		
- 8	6 ~ 8			22		
-10	8 ~ 10					
-12	10 ~ 12					
-13	11 ~ 13					

Tap sleeve (HFT,HUT)

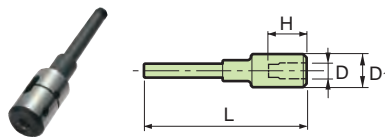

CODE	φD	L	φD₁	H	Holder type
TA 4-M 2	M 2	67.5	16	19	HFT 4
-M 3	M 3			20	HUT 4
-M 4	M 4			21	
-M 5	M 5				
-M 6	M 6				
-M 8	M 8				
TA 6-M 3	M 3	92	19	21	HFT 6
-M 4	M 4			22	HUT 6
-M 5	M 5				HFT12
-M 6	M 6				
-M 8	M 8				
-M10	M10				
-M12	M12			24	
TA12-M14	M14	111.5	25	33	HFT12
-M16	M16			35	

■Note

• Above products meet JIS standards. We can produce other standard tap sleeves, such as ANSI, ISO, DIN and others. For more information, please contact us.

Spring collet (HFA,HUA)

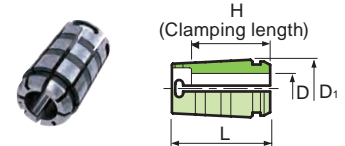

CODE	φD	φD₁	L	H	Holder type
C10-D	2.6 2.8 3 ...	17.2	26	16 (φD=2.6~5)	HFA10
	0.2 steps			※Except for 3, 4	HUA10
C20-D	6 6.2 6.4 ...	29.5	50	18 (φD=3, 4, 5.2~5.8)	HFA20
	0.2 steps			20 (φD=6~10)	HUA20
	... 19.8 20			32 (φD=6~9.8)	
				35 (φD=10~15.8)	
				40 (φD=16~20)	

Ex. φD
C10-6

CODE	Fig.	φD	L	M	Kg
BT30-HFD 7 -122	1	1 ~ 7	122	70	2.3
			182	130	3.0
-HFD 7L-120			120	57	1.8
-HFD12 -122	2	2.5 ~ 13	122	70	2.9
-HFA10 -120	3	2.4 ~ 10	120	65	1.8
-HFT 4 -122	5	M2 ~ M 8	122	70	2.3
			182	130	3.0
-HFT 4L-120			120	57	1.8
-HFT 6 -122	6	M3 ~ M12	122	70	2.9
BT40-HFD 7 -120	1	1 ~ 7	120	70	3.0
			180	130	3.3
-HFD12 -120	2	2.5 ~ 13	120	70	3.6
-180			180	130	4.9
-HFA20 -135	4	5.8 ~ 20	135	77	4.4
			195	137	5.6
-HFT 4 -120	5	M2 ~ M 8	120	70	3.0
			180	130	3.3
-HFT 6 -120	6	M3 ~ M12	120	70	3.6
			180	130	4.9
-HFT12 -135	7	M3 ~ M16	135	77	4.4
			195	137	5.6
BT50-HFD 7 -195	1	1 ~ 7	195	130	6.4
			255	190	6.8
-HFD12 -135	2	2.5 ~ 13	135	70	6.3
			195	130	7.6
			255	190	8.9
-HFA20 -150	4	5.8 ~ 20	150	77	7.1
			210	137	8.3
			270	197	9.4
-HFT 4 -195	5	M2 ~ M 8	195	130	6.4
			255	190	6.8
-HFT 6 -135	6	M3 ~ M12	135	70	6.3
			195	130	7.6
			255	190	8.9
-HFT12 -150	7	M3 ~ M16	150	77	7.1
			210	137	8.3
			270	197	9.4
A63 -HFD 7 -183	1	1 ~ 7	183	130	3.5
			243	190	3.9
-HFD12 -123	2	2.5 ~ 13	123	70	3.3
			183	130	4.7
			243	190	6.0
-HFA20 -198	4	5.8 ~ 20	198	137	5.4
			258	197	6.5
-HFT 4 -183	5	M2 ~ M 8	183	130	3.5
			243	190	3.9
-HFT 6 -123	6	M3 ~ M12	123	70	3.3
			183	130	4.7
			243	190	6.0
-HFT12 -198	7	M3 ~ M16	198	137	5.4
			258	197	6.5

■ Option

- DETa-1 Collet (HFD)→P.4 • Spring collet (HFA) →P.4 • Tap sleeve (HFT) →P.4
- Retention knob • Tools for assembly

■ Std. Access.

- Coolant duct (HSK-A) • Fixing spanner(Except for HFA10/HFT4L) • Hexagonal wrench set
- Spanner(HFA) • Single-ended wrench (HFD7L/HFA10) • Spanner(HFA)

■ Note

- Other shanks are also available upon request.

CODE	Fig.	φD	L	M	Kg
DN40A-HFD 7-135	1	1 ~ 7	135	70	3.1
			195	130	3.4
-HFD12-135	2	2.5~ 13	135	70	3.7
			195	130	5.0
-HFD20-150	4	5.8~ 20	150	77	4.7
			210	137	5.8
-HFT 4-135	5	M2~M 8	135	70	3.1
			195	130	3.4
-HFT 6-135	6	M3~M12	135	70	3.7
			195	130	5.0
-HFT12-150	7	M3~M16	150	77	4.7
			210	137	5.8
DN50A-HFD 7-195	1	1 ~ 7	195	130	5.9
			255	190	6.3
-HFD12-135	2	2.5~ 13	135	70	5.8
			195	130	7.1
			255	190	8.4
-HFA20-150	4	5.8~ 20	150	77	6.6
			210	137	7.8
			270	197	8.9
-HFT 4-195	5	M2~M 8	195	130	5.9
			255	190	6.3
-HFT 6-135	6	M3~M12	135	70	5.8
			195	130	7.1
			255	190	8.4
-HFT12-150	7	M3~M16	150	77	6.6
			210	137	7.8
			270	197	8.9
CT40 -HFD 7-135	1	.04~.28	5.31	2.75	6.8
			7.68	5.11	7.5
-HFD12-135	2	.10~ .51	5.31	2.75	8.2
			7.68	5.11	11.0
-HFA20-150	4	.23~ .79	5.91	3.03	10.4
			8.27	5.39	12.9
-HFT 4-135	5	M2~M 8	5.31	2.75	6.8
			7.68	5.11	7.5
-HFT 6-135	6	M3~M12	5.31	2.75	8.2
			7.68	5.11	11.0
-HFT12-150	7	M3~M16	5.91	3.03	10.4
			8.27	5.39	12.9
CT50 -HFD 7-195	1	.04~ .28	7.68	5.11	13.0
			10.04	7.47	13.8
-HFD12-135	2	.10~ .51	5.31	2.75	12.8
			7.68	5.11	15.6
			10.04	7.47	18.5
-HFA20-150	4	.23~ .79	5.91	3.03	14.7
			8.27	5.39	17.3
			10.63	7.76	19.8
-HFT 4-195	5	M2~M 8	7.68	5.11	13.0
			10.04	7.47	13.8
-HFT 6-135	6	M3~M12	5.31	2.75	12.8
			7.68	5.39	15.6
			10.04	7.47	18.5
-HFT12-150	7	M3~M16	5.91	3.03	14.7
			8.27	5.39	17.3
			10.63	7.76	19.8

■ A product code example when ordering.

BT40 - HFD7-120 - S 65

Model no.

Positioning pin type

- S: Straight pin
- W: Expansion pin
- T: Taper pin

Dimension S

- 50, 60, 65, 80, 85, 110mm ...

HALF mini type



BT40-HFCS6-205

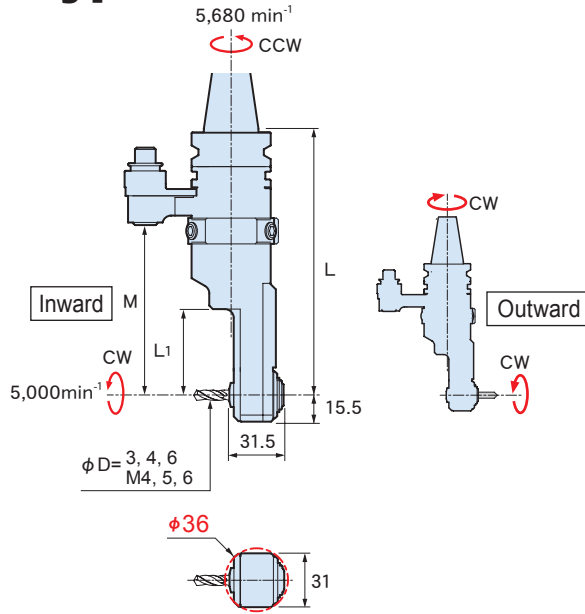
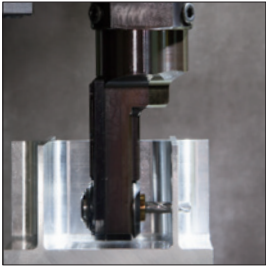

Cutter mounts in two directions

A cutting tool can be mounted both ways, inward or outward, by reassembling the angle shaft.

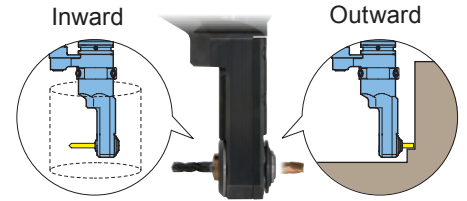

Allows maximum tool holder diameter limitation even when using a long cutting tool.

Minimal interference with face of workpiece.

Collet exchange system

Shaft exchange system for Shrink-fit collet for carbide cutter (end-mill, drill) or Tap collet for Tap.

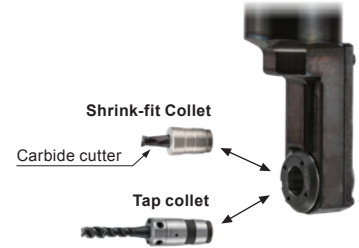

CODE	φD	L	L ₁	M	Kg lbs
BT30 -HFCS6-155	Drill Endmill φ 3, 4, 6	155	50	100	1.8
BT40 -HFCS6-160		160	50	110	2.8
-205		205	95	155	3.0
BT50 -HFCS6-175	Tap M4, 5, 6	175	50	110	5.6
-220		220	95	155	5.8
DN40A-HFCS6 -175	Drill Endmill φ 3, 4, 6	175	50	110	3.0
-220		220	95	155	3.2
DN50A-HFCS6-175	Tap M4, 5, 6	175	50	110	5.1
-220		220	95	155	5.3
CT40 -HFCS6-175	Drill Endmill φ 3, 4, 6	6.89	1.97	4.33	6.61
-220		8.66	3.74	6.10	7.28
CT50 -HFCS6-175	Tap M4, 5, 6	6.89	1.97	4.33	11.24
-220		8.66	3.74	6.10	11.68

DIN

CAT.

- Option
 - Shrink-fit collet
 - Tap collet
 - Retention knob
 - Tools for assembly

- Std. Access.
 - Fixing spanner
 - Hexagonal wrench set

- Note
 - When shipping, the head direction is inward.
 - The tool for assembly (pliers for retaining ring) is required to reassemble the collet to allow for outward positioning of the cutting tool.
 - Other shanks such as HSK are also available upon request.

- Caution
 - The angle axis rotating direction is different due to its mounting direction, inward and outward.

Shrink-Fit Collet

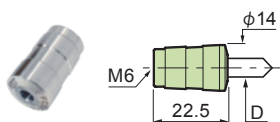

CODE	φD	Holding length
FCS6- 3	3	11~13
- 4	4	
- 6	6	12~13

- Caution
 - The dedicated shrink-fit collet for the Angle Head Half, Mini.
 - A shrink-fit heating device is required to insert and remove cutting tools.

Tap collet

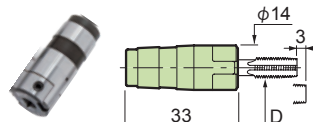

CODE	φD	Holding length
FCS6-M4	M4	16
-M5	M5	
-M6	M6	

- Note
 - Tap collets meet JIS standards.
 - We can produce ANSI standard tap collet.
 - For more information, please contact us.

A product code example when ordering.

BT30 - HFCS6 - 155 - S 65

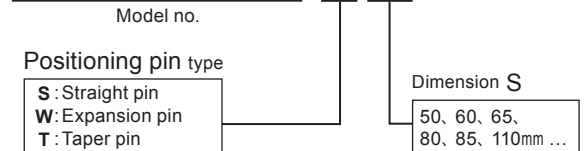

Procedure of cutter insertion to shrink-fit collet

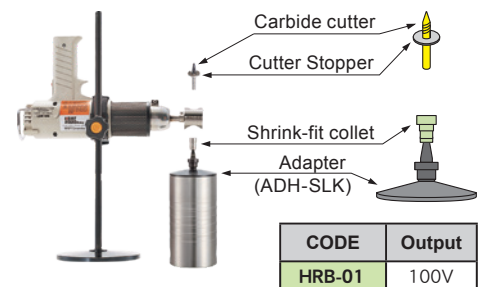

CODE	Output
HRB-01	100V

Shrink-fit Heater (HRB-01)

- Attach the shrink-fit collet to the adapter (ADH-SLK).
- Heat the shrink-fit collet with the shrink-fit heater.
- Attach a stopper to the carbide cutter. After finishing heating, insert the cutter to the shrink-fit collet.
- Cool the shrink-fit collet with the shrink-fit heater.

HALF UNIVERSAL type

Drill · Endmill

Tap

Fig. 1

HUD7
()...BT30

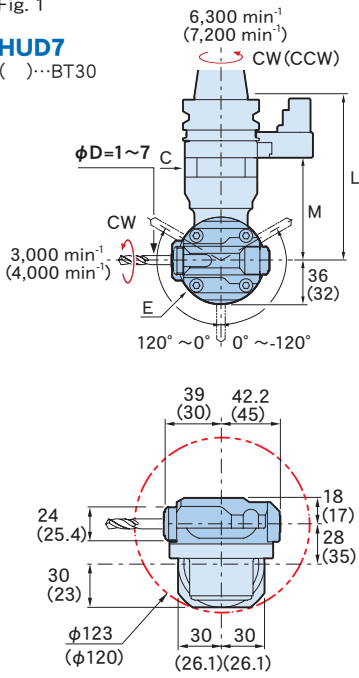

Fig. 2

HUA10

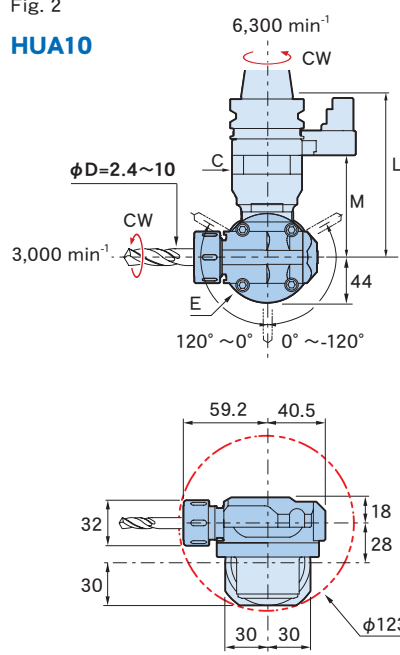

Fig. 4

HUT4
()...BT30

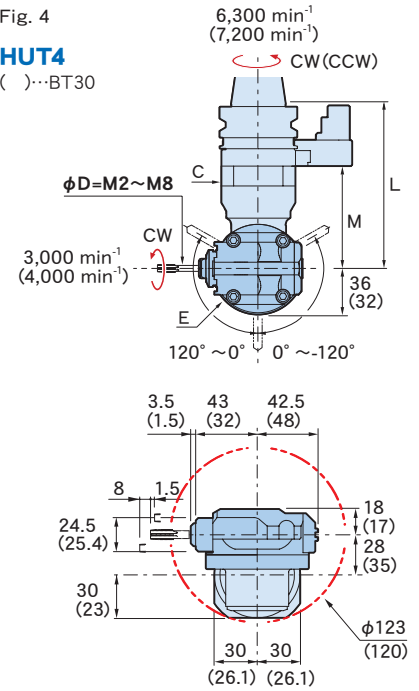

Fig. 3

HUA20

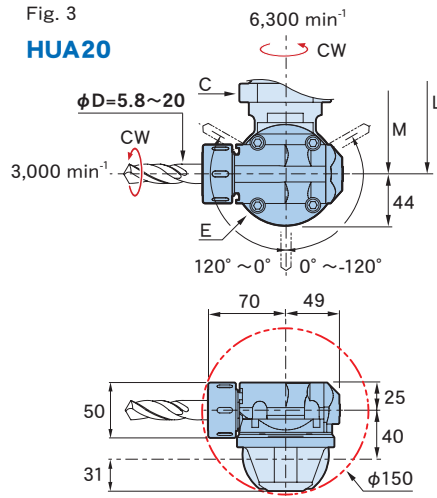
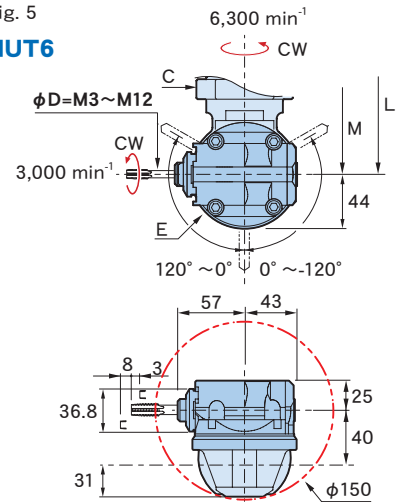

Fig. 5

HUT6



BT40-HUA20-135



CODE	Fig.	φD	L	M	φC	φE	Kg lbs	※Moment kgf·mm
BT30 -HUD 7-102	1	1 ~ 7	102	39	46	64	1.8	116
-HUT 4-102	4	M2 ~ M 8						
BT40 -HUD 7-135	1	1 ~ 7	135	85	60	72	3.8	251
-HUA10-135	2	2.4 ~ 10						
-HUA20-135	3	5.8 ~ 20						
-HUT 4-135	4	M2 ~ M 8						
-HUT 6-135	5	M3 ~ M12						
			85	60	72	3.8	251	
			77	78	88	4.8	392	
BT50 -HUD 7-150	1	1 ~ 7	150	85	60	72	6.6	277
-HUA10-150	2	2.4 ~ 10						
-HUA20-150	3	5.8 ~ 20						
-HUT 4-150	4	M2 ~ M 8						
-HUT 6-150	5	M3 ~ M12						
			85	60	72	6.6	277	
			77	78	88	7.5	440	
DN40A -HUD 7-150	1	1 ~ 7	150	85	60	72	3.8	251
-HUA10-150	2	2.4 ~ 10						
-HUA20-150	3	5.8 ~ 20						
-HUT 4-150	4	M2 ~ M 8						
-HUT 6-150	5	M3 ~ M12						
			85	60	72			
			77	78	88			
DN50A -HUD 7-150	1	1 ~ 7	150	85	60	72	6.6	277
-HUA10-150	2	2.4 ~ 10						
-HUA20-150	3	5.8 ~ 20						
-HUT 4-150	4	M2 ~ M 8						
-HUT 6-150	5	M3 ~ M12						
			85	60	72	6.6	277	
			77	78	88	7.0	440	
CT40 -HUD 7-150	1	.04 ~ .28	5.91	3.3	2.4	2.8	8.4	251
-HUA10-150	2	.09 ~ .39						
-HUA20-150	3	.23 ~ .79						
-HUT 4-150	4	M2 ~ M 8						
-HUT 6-150	5	M3 ~ M12						
			3.3	2.4	2.8	8.6	268	
			3.0	3.1	3.5	11.0	392	
			3.3	2.4	2.8	8.4	251	
			3.0	3.1	3.5	11.0	392	
CT50 -HUD 7-150	1	.04 ~ .28	5.91	3.3	2.4	2.8	14.6	277
-HUA10-150	2	.09 ~ .39						
-HUA20-150	3	.23 ~ .79						
-HUT 4-150	4	M2 ~ M 8						
-HUT 6-150	5	M3 ~ M12						
			3.3	2.4	2.8	14.8	295	
			3.0	3.1	3.5	15.4	440	
			3.3	2.4	2.8	14.6	277	
			3.0	3.1	3.5	15.4	440	

※Distance from a gage line to center of gravity x weight (kg · mm)

■Option

- DETa-1 Collet (HUD)→P.4 • Spring collet (HUA)→P.4
- Tap sleeve (HUT)→P.4 • Retention knob • Tools for assembly

■Std. Access.

- Fixing spanner • Hexagonal wrench set • Spanner (HUA)

■Note

- Other shanks such as HSK are also available upon request.

■A product code example when ordering.

BT50-HUA20-150 - S 65

Model no.

Positioning pin type

- S : Straight pin
- W : Expansion pin
- T : Taper pin

Dimension S

- 50, 60, 65, 80, 85, 110mm ...

■Angle Head HALF cutting data

90° type

S55C φ12 Drill

N 670 min⁻¹
F 80 mm/min
V 25.5 m/min
f 0.12 mm/rev

BT40-HFD12-120

S55C M12 Tap

N 184 min⁻¹
F 322 mm/min
V 7 m/min

BT40-HFT6-120

S50C M16 Tap

N 60 min⁻¹
F 120 mm/min
V 3 m/min

BT40-HFT12-135

S55C φ10 Endmill 2-flutes

N 350 min⁻¹
F 50 mm/min
V 11 m/min
fz 0.07 mm/t

BT40-HFD12-120

S50C φ20 Endmill 2-flutes

N 158 min⁻¹
F 32 mm/min
V 10 m/min
fz 0.10 mm/t

BT40-HFA20-135

mini type

S50C Carbide drill φ6

N 5000 min⁻¹
F 250 mm/min
V 94 m/min
f 0.05 mm/rev

BT30-HFCS6-155

S50C Carbide endmill 2-flutes φ6

N 3500 min⁻¹
F 210 mm/min
V 66 m/min
fz 0.03 mm/t

BT40-HFCS6-205

A7075 Carbide endmill 2-flutes φ6

N 5000 min⁻¹
F 300 mm/min
V 94 m/min
fz 0.03 mm/t

BT30-HFCS6-155

UNIVERSAL type

S50C φ10 Endmill 2-flutes

N 900 min⁻¹
F 100 mm/min
V 28 m/min
fz 0.06 mm/t

BT50-HUA10-150

S50C M8 Tap

N 250 min⁻¹
F 312 mm/min
V 6.3 m/min

BT40-HUT4-135

S50C M12 Tap

N 184 min⁻¹
F 322 mm/min
V 7 m/min

BT40-HUT6-135

SUS304 φ10 Drill

N 314 min⁻¹
F 16 mm/min
V 9.9 m/min
f 0.05 mm/rev

BT50-HUA10-150

S50C φ16 Endmill 2-flutes

N 140 min⁻¹
F 40 mm/min
V 7 m/min
fz 0.14 mm/t

BT40-HUA20-135

ANGLE HEAD STANDARD type

High-rigidity standard type for end-milling applications

MODULAR type

Shank and head can be combined freely to match the application.

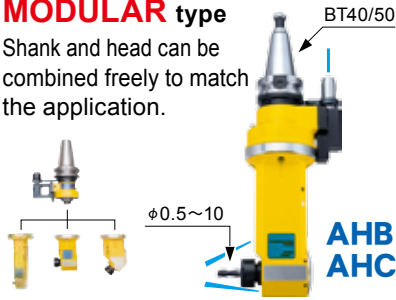

SOLID type

The popular type that can chuck small- to large-diameter cutters.

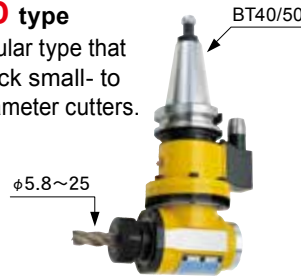

FLANGE type

Heavy-duty type that mounts directly on the machine spindle surface.



UNIVERSAL type

Cutting angle can be adjusted arbitrarily.

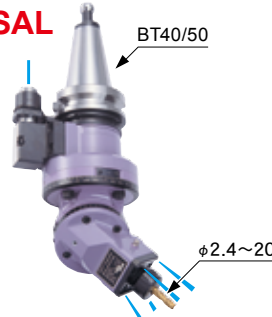

High rigidity

To chuck a cutting tool, the collet chuck system is used, which has a long history of good performance. This product is applicable to all the types of machining, including drilling and milling.



Compact design

Ideal for internal machining.

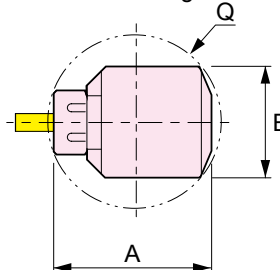

Type	CODE	Q	A	B
MODULAR type	AHB 5	57	46	62
	AHB 7	72	56	76
	AHB10	88	62	96
SOLID type FLANGE type	AHA20	160	88	171
	AHA25	180	90	193
UNIVERSAL type	AHU10	154	27.5	156
	AHU20	188.5	35	192

Body-through coolant

Coolant can be feed from a closer position to the cutting edge. Prevents heat generation inside the body to achieve high-speed rotation.

(MODULAR type, UNIVERSAL type)

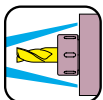

MST's Quick Change system (AHD type)

By adopting the BT30 Quick Change mechanism at the angle axis, a large variety of machining applications are made possible.



Highest Guaranteed Accuracies

All standard type angle heads have passed an accuracy test and rotation test.

Squareness

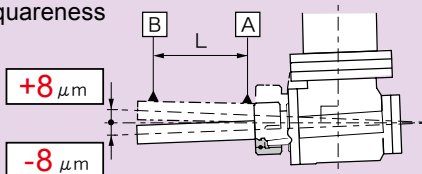

Runout accuracy

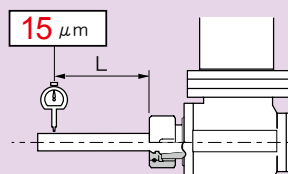

Type	CODE	L
MODULAR type	AHB 5	40
	AHB 7	
	AHB10	
	AHC10	
UNIVERSAL type	AHU10	50
SOLID type FLANGE type	AHA20	
	AHA25	
UNIVERSAL type	AHD30	
UNIVERSAL type	AHU20	

MODULAR type

Shank and head can be combined freely to match the application.

▷ Various types of shanks and heads are freely combined to meet your machining needs.

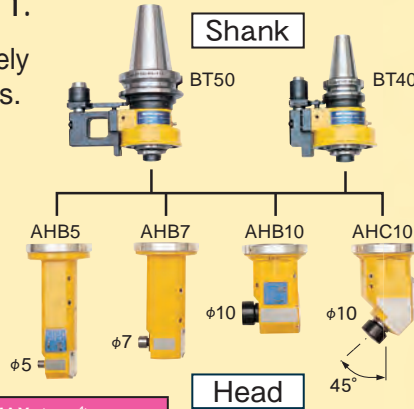

BT50-AHB10-210

Type	Chucking range	Gear ratio Main spindle:Angle shaft	MAX. (min ⁻¹)
			Main spindle(CCW) : Angle shaft (CW)
AHB 5	φ0.5~ 5	1:1	5,000:5,000
AHB 7	φ0.5~ 7		6,000:6,000
AHB10	φ2.4~10		(When using body thru-coolant)
AHC10			

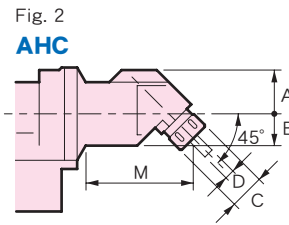
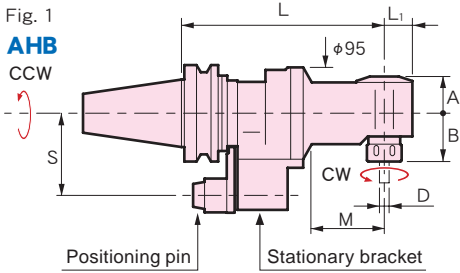

CODE	Fig.	φD	L	φC	L ₁	M	A	B	G	φQ	Kg		
BT40-AHB 5-210	1	0.5~ 5	210	12	20	85	25	32	46	62	5.5	ER8	
-270			270			145					6.4		
-AHB 7-180		0.5~ 7	180	19	22	60	29	43	56	76	5.3	ESX12	
-240			240			120					6.6		
-AHB10-195		2	2.4~10	195	36	29	80	38	50	62	96	6.2	C10
-255				255			140					7.9	
-AHC10-230	230		-	110	45	32.5	65	-	6.2				
BT50-AHB 5-225	1		0.5~ 5	225	12	20	85	25	32	46	62	8.8	ER8
-285		285		145			9.7						
-AHB 7-195		0.5~ 7	195	19	22	60	29	43	56	76	8.6	ESX12	
-255			255			120					9.9		
-AHB10-210		2	2.4~10	210	36	29	80	38	50	62	96	9.5	C10
-270				270			140					11.2	
-AHC10-245	245		-	110	45	32.5	65	-	9.5				

■ Option

- Spring collet→P.14
- Retention knob
- Semi-finished positioning block→P.14

■ Std. Access.

- A complete set of spanners and wrenches.

■ Note

- The phase of the drive key and the positioning pin may be set freely.
- Standard specifications: S = 60 mm, 65 mm (BT40), 80 mm, 85 mm, and 110 mm (BT50).
- Other shanks such as HSK, DIN and CAT. are also available upon request.

■ Caution

- For the shape and mounting position of the positioning block, contact the machine manufacturer or MST.
- The height of the positioning pin depends on the shape of the positioning block.
- The machine spindle and angle shaft should rotate in reverse directions, so make sure the spindle rotates in the reverse direction.

Shank / Head reference list

CODE	Shank	Head	
BT40-AHB 5-210	BT40-MS-98	MB 5-112	
-270		-172	
-AHB 7-180		MB 7- 82	
-240		-142	
-AHB10-195		MB10- 97	
-255		-157	
-AHC10-230		MC10-132	
BT50-AHB 5-225	BT50-MS-113	MB 5-112	
-285		-172	
-AHB 7-195		MB 7- 82	
-255		-142	
-AHB10-210		MB10- 97	
-270		-157	
-AHC10-245			MC10-132

SOLID type

The popular type that can chuck small- to large-diameter cutters.



Type	Chucking range	Gear ratio		MAX. (min ⁻¹)
		Main spindle : Angle shaft	Main spindle(CCW) : Angle shaft(CW)	
AHA 20	$\phi 5.8 \sim 20$	1 : 0.81	3000 : 2430	
AHA 25	$\phi 5.8 \sim 25$	1 : 0.96	2500 : 2400	
AHD 30	BT30 tools			

Fig. 1
AHA

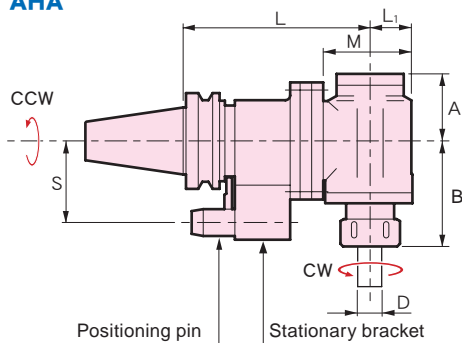
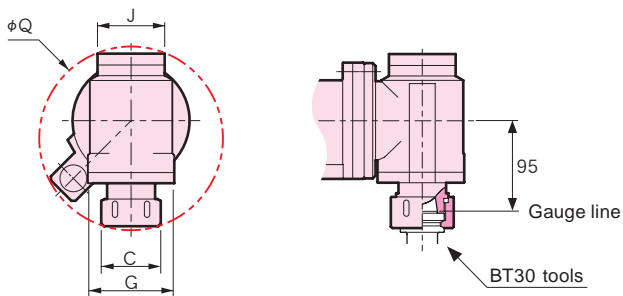

Fig. 2
AHD



CODE	Fig.	ϕD	L	L ₁	M	A	B	G	ϕC	J	ϕQ	Kg	
BT40-AHA20-160	1	5.8~20	160	40	86	65	95	88	50	65	171	7.3	C20
BT50-AHA20-195	1	5.8~20	195	40	92	65	95	88	50	65	171	13.1	C20
-250			249									14.8	
-AHA25-195		5.8~25	195	44	97	70	110	90	62	70	193	13.6	C25
-250			249									15.3	
-AHD30-195	2	—	195				112.6		66			14.7	—

Option

- Spring collet→P.14
- Retention knob
- Semi-finished positioning block→P.14

Std. Access.

- A complete set of spanners and wrenches

Note

- The phase of the drive key and the positioning pin may be set freely.
- Standard specifications: S = 60 mm, 65 mm (BT40), 80 mm, 85 mm, and 110 mm (BT50).
- Other shanks such as HSK, DIN and CAT. are also available upon request.

Caution

- For the shape and mounting position of the positioning block, contact the machine manufacturer or MST.
- The height of the positioning pin depends on the shape of the positioning block.
- The machine spindle and angle shaft should rotate in reverse directions, so make sure the spindle rotates in the reverse direction.

FLANGE type

Heavy cutting is possible by mounting the angle head flange type directly on the machine spindle surface.

▷ This angle head is applicable to heavy cutting by mounting to the machine spindle.



Type	Chucking range	Gear ratio	
		Main spindle : Angle shaft	MAX. min ⁻¹ Main spindle(CCW):Angle shaft(CW)
AHA20	φ5.8~20	1:0.81	3000:2430
AHA25	φ5.8~25	1:0.96	2500:2400
AHD30	BT30 tools	1:0.96	

Fig. 1

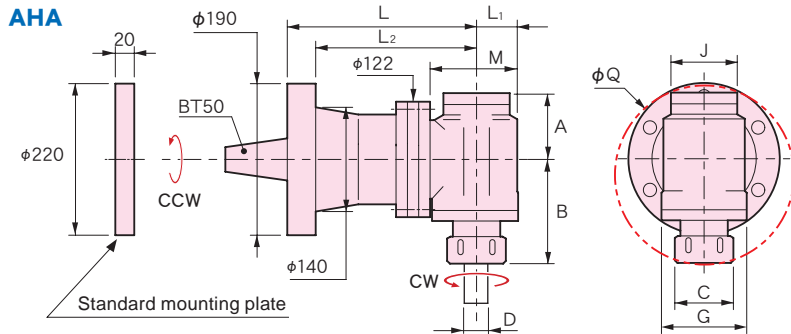
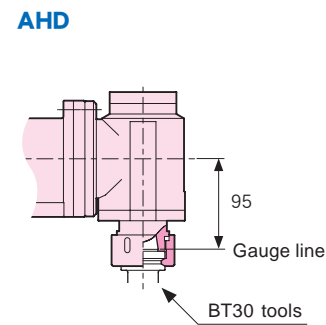

Fig. 2



CODE	Fig.	φD	L	L ₁	L ₂	M	A	B	G	φC	J	φQ	kg	Icon
F190-AHA20-200	1	5.8~20	200	40	160	92	65	95	88	50	65	171	18	C20
-350			350		310								28	
-AHA25-200		5.8~25	200	44	160	97	70	110	90	62	70	193	18.5	C25
-350			350		310								28.5	
-AHD30-200	2	—	200		160					66			19.6	—
-350			350		310								29.8	

■ Option

- Spring collet→P.14
- Retention knob

■ Std. Access.

- A complete set of spanners and wrenches
- Standard mounting plate(No mounting holes are provided.)
- Mounting bolts for ANGLE HEAD

■ Note

- NT50U shank is also available.

■ Caution

- For mounting plate shapes and mounting bolt location, contact the machine manufacturer or MST.
- The machine spindle and angle shaft should rotate in reverse directions, so make sure the spindle rotates in the reverse direction.

UNIVERSAL type

Machining at every angle is possible with just this one unit.

Splash coolant-through body

Whatever machining angle is set, coolant is properly supplied to the cutting edge.

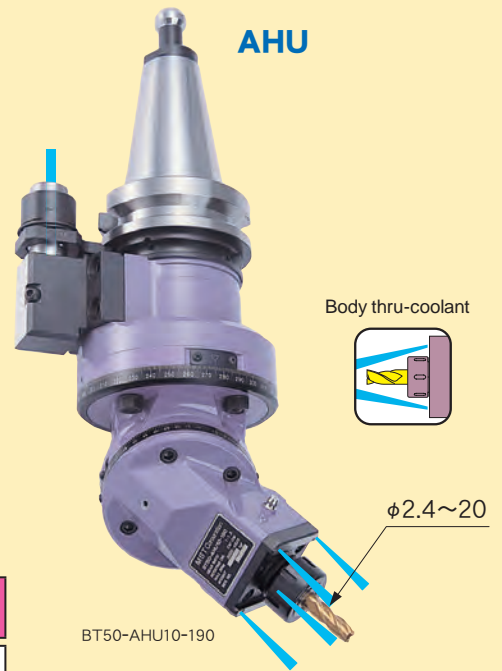
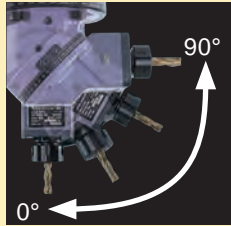
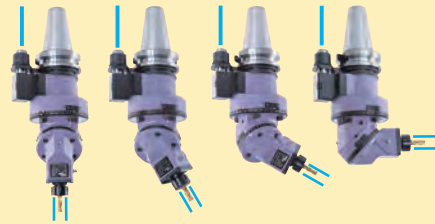

BT50-AHU10-190

Type	Chucking range	Gear ratio Main spindle : Angle shaft	MAX. (min ⁻¹) Main spindle(CCW):Angle shaft(CW)
AHU10	φ2.4~10	1 : 1.5	3000 : 4500
AHU20	φ5.8~20	1 : 1	3000 : 3000

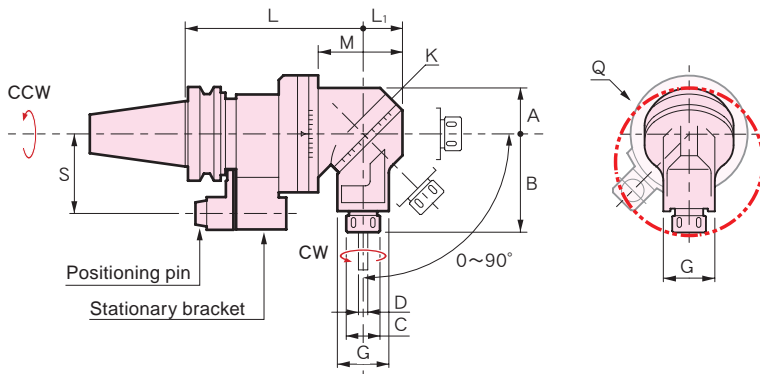

CODE	φD	L	L ₁	M	A	B	K	G	φC	φQ	Kg	
BT40-AHU10-175	2.4~10	175	42	96	49	105	95	55	32	156	9.6	C10
BT50-AHU10-190	2.4~10	190	42	90	49	105	95	55	32	192	13.9	C10
-AHU20-200	5.8~20	200	54	112	58.5	130	120	70	50		15.8	C20

Option

- Spring collet →P.14
- Retention knob
- Semi-finished positioning block →P.14
- Test bar

Std. Access.

- A complete set of spanners and wrenches

Note

- The phase of the drive key and the positioning pin may be set freely.
- Standard specifications: S = 60 mm, 65 mm (BT40), 80 mm, 85 mm, and 110 mm (BT50).
- Other shanks such as HSK, DIN and CAT. are also available upon request.

Caution

- For the shape and mounting position of the positioning block, contact the machine manufacturer or MST.
- The machine spindle and angle shaft should rotate in reverse directions, so make sure the spindle rotates in the reverse direction.
- The machine spindle and angle shaft should rotate in forward directions, so make sure the spindle rotates in the forward direction.

Test bar

Use for super accurate angle adjustment.

CODE	Holder type
TBU10	AHU10
TBU20	AHU20



SPRING COLLET

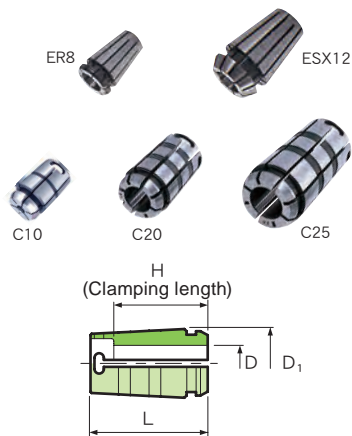

CODE	ϕD	ϕD_1	L	H	Holder type
ER8-D	1 ~ 5 (0.5 steps)	8.5	13.5	-	AHB 5
ESX12-D	1 ~ 3 (0.5 steps)	12	19.5	-	AHB 7
	4 ~ 7 (1.0 steps)				
C10-D	2.6 ~ 5.8 (0.2 steps)	17.2	26	18	AHB10 AHC10 AHU10
	6 ~ 10 (0.2 steps)			20	
C20-D	6 ~ 9.8 (0.2 steps)	29.5	50	29	AHA20 AHU20
	10 ~ 15.8 (0.2 steps)			33	
	16 ~ 20 (0.2 steps)			40	
C25-D	6, 8	36.5	68	35	AHA25
	10 ~ 15 (0.5 steps)			46	
	15.5 ~ 20 (0.5 steps)			54	
	20.5 ~ 25 (0.5 steps)			57	

■Option ●Collet remover (C10, C20)

Semi-finished positioning block

The semi-finished positioning block must be modified to the appropriate shape by the customer after delivery.

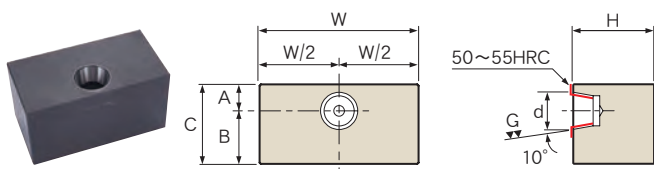

CODE	A	B	C	W	H	d	Main spindle	Material
AB-15	15	43	58	92	58	20	BT40	S50C
-12	20		63	120	63	28	BT50	

Determine the shape and dimensions as follows, and then modify the positioning block as necessary.

- Obtain the machine manufacturer's drawing for the positioning block and modify the positioning block in accordance with that drawing.
- Determine the dimensions as shown in the instruction and then modify.
 - This block may not be applicable for dimensional reasons. Carefully check to see whether the positioning block is applicable.
 - The positioning block exclusively for your machine may also be available on request.
 - For further information, please contact MST.

Custom-made products

We are proud of our over 30 years of experience custom making products for our customers. We can produce the best product for you depending on your applications such as O.D and I.D machining thanks to our accumulated know-how.

Custom-made Portfolio

1
unit

Production starting from just 1 unit

2~6
months

Delivery

16,200
units

Manufacturing history



For more information, please contact MST Corporation.

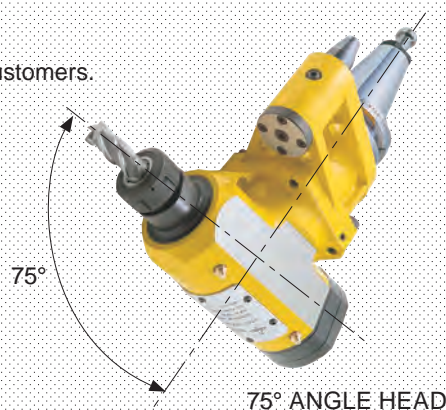

Dual side machining ANGLE HEAD

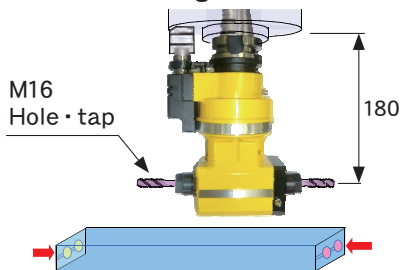

Side face machining ANGLE HEAD

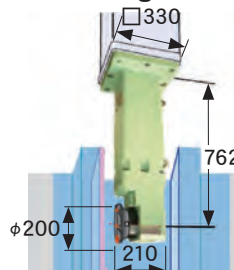

Internal bore surface machining ANGLE HEAD

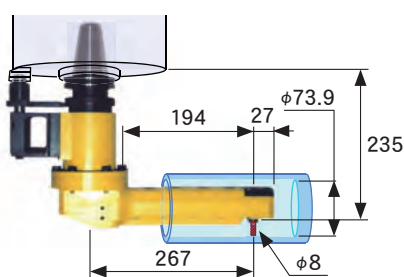

Internal bore surface machining ANGLE HEAD

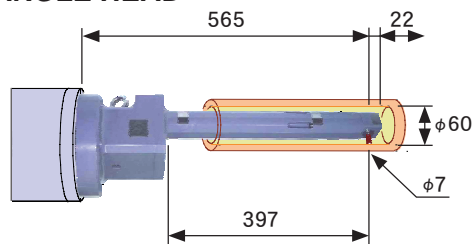

■ ANGLE HEAD (STANDARD type) cutting data



MODULAR type

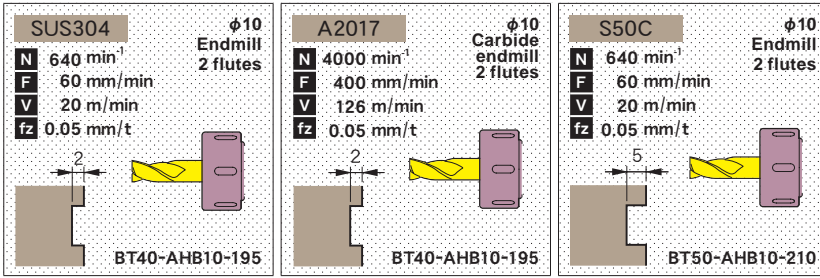

SOLID type

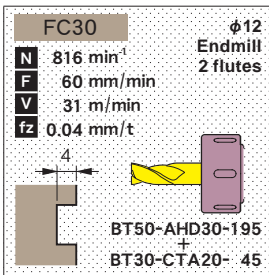
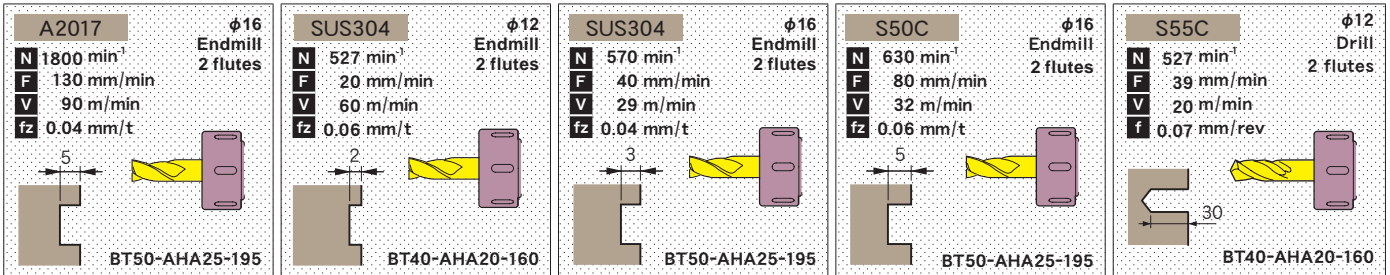



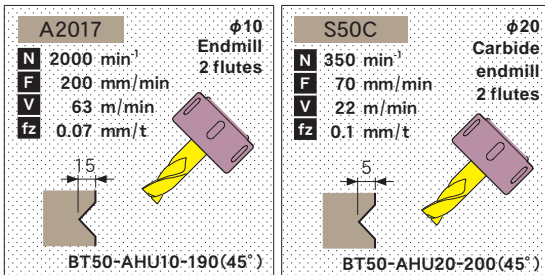

UNIVERSAL type







ANGLE HEAD voluminous variety

■ New concept Angle Head **HALF** for drilling and tapping applications **Lightweight • Shorter delivery • Affordable!**

Type	Angle	CODE	Intended purpose	Chucking range (φD)	Collet type	MAX. min ⁻¹ [Main spindle(CCW):Angle shaft (CW)]	ATC	 (Typical holder)	
90° type  ↻ P.4  minitype ↻ P.6	90°	HFCS6	Drill Endmill	φ3, 4, 6	FCS6	5680:5000 [1 : 0.88]	○	1.8	
		HFD 7 HFD 7L		φ1 ~ 7	D 7	6000:6000 [1(CCW):1(CW)]			
		HFD12		φ2.5 ~ 13	D12	4000:4000 [1(CCW):1(CW)]			
		HFA10		Tap	φ2.4 ~ 10	C10		6000:6000 [1(CCW):1(CW)]	1.8
		HFA20			φ5.8 ~ 20	C20		6000:5000 [1(CCW):0.83(CW)]	4.4
		HFCS6			M4, 5, 6	FCS6		5680:5000 [1 : 0.88]	1.8
		HFT 4 HFT 4L	M2 ~ 8	TA4	6000:6000 [1(CCW):1(CW)]	2.3			
		HFT 6	M3 ~ 12	TA6	4000:4000 [1(CCW):1(CW)]	2.9			
		HFT12	M3 ~ 16	TA6/12	6000:5000 [1(CCW):0.83(CW)]	4.4			
UNIVERSAL type (Free setting of cutting directions) ↻ P.7 	0° ∩ 120°	HUD 7	Drill Endmill	φ1 ~ 7	D 7	6300(7200):3000(4000) [1(CCW):0.48(CW)]	○	1.8	
		HUA10		φ2.4 ~ 10	C10	6300:3000 [1(CW):0.48(CW)]		3.9	
		HUA20		φ5.8 ~ 20	C20	6300:3000 [1(CW):0.48(CW)]		4.8	
		HUT 4	Tap	M2 ~ 8	TA4	6300(7200):3000(4000) [1(CCW):0.48(CW)]		3.8	
		HUT 6		M3 ~ 12	TA6	6300:3000 [1(CW):0.48(CW)]		4.8	

■ High-rigidity **STANDARD** type for end-milling applications

MODULAR type (Recombination type) ↻ P.10 	90°	AHB 5	Drill Endmill	φ0.5~ 5	ER8	6000:6000 [1(CCW):1(CW)]	○	5.5
		AHB 7		φ0.5~ 7	ESX12			5.3
		AHB10		φ2.4~10	C10			6.2
SOLID type ↻ P.11 	90°	AHA20	Drill Endmill	φ5.8~20	C20	3000:2430 [1(CCW):0.81(CW)]	○	7.3
		AHA25		φ5.8~25	C25	2500:2400 [1(CCW):0.96(CW)]		13.6
		AHD30		BT30*	BT30	14.7		
FLANGE type (Mounting directly on machine spindle) ↻ P.12 	90°	AHA20	Drill Endmill	φ5.8~20	C20	3000:2430 [1(CCW):0.81(CW)]	×	18.0
		AHA25		φ5.8~25	C25	2500:2400 [1(CCW):0.96(CW)]		18.5
		AHD30		BT30*	BT30	19.6		
UNIVERSAL type (Free setting of cutting directions) ↻ P.13 	0° ∩ 90°	AHU10	Drill Endmill	φ2.4~10	C10	3000:4500 [1(CW):1.5(CW)]	○	9.6
		AHU20		φ5.8~20	C20	3000:3000 [1(CW):1(CW)]		15.8

(※Use the BT30 tooling system with the Quick Change system.)

■ Custom-made products

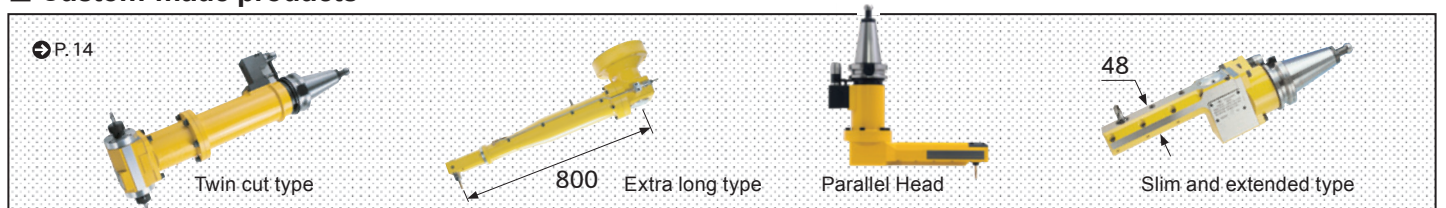

MST corporation

1738 Kitatahara Ikoma Nara 630-0142 Japan
TEL:81-743-78-1931 FAX:81-743-78-3854

<http://www.mst-corp.co.jp>