

# Tag Stamping

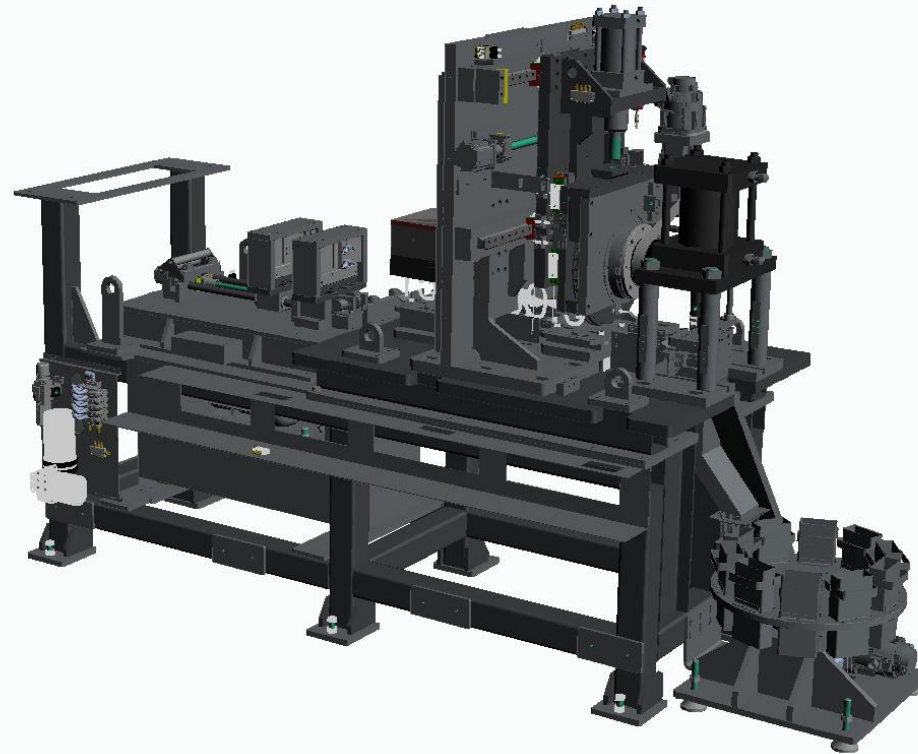

Dec 2023 V1 KW



**GDM  
ID Tag**

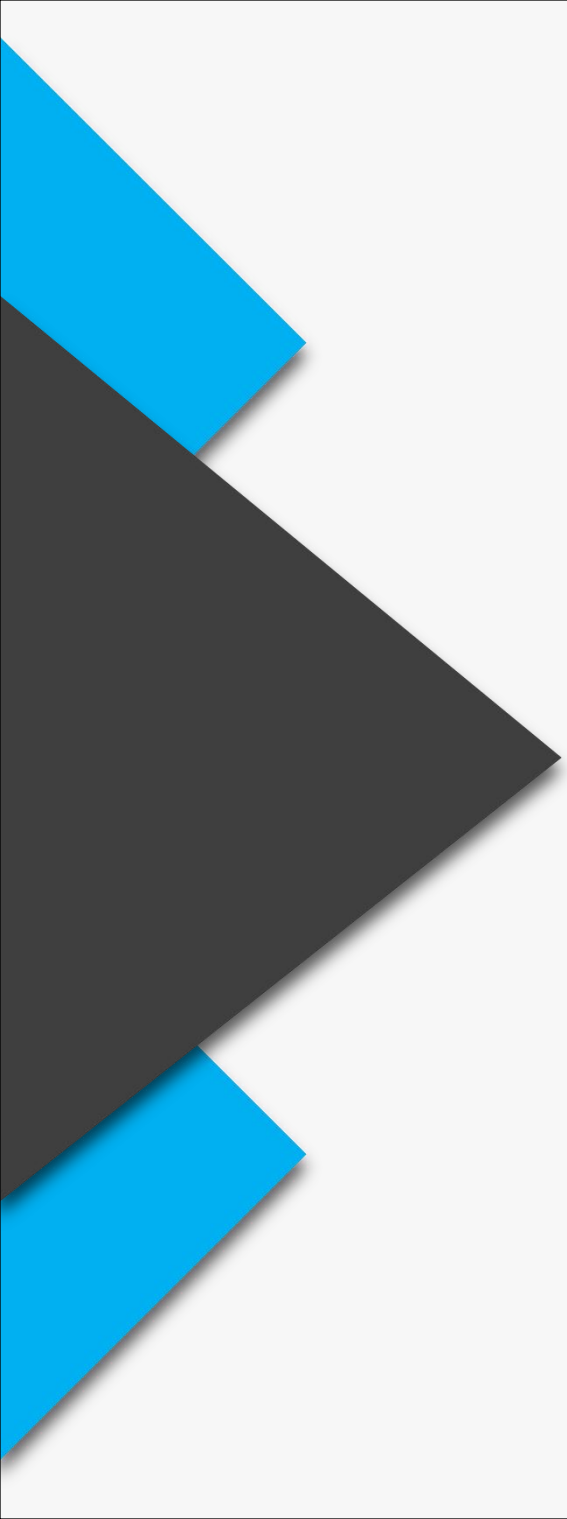

# Importance of Beam Marking



- to locate the steel beam
- to identify the steel beam
- to clarify the specification
- to find out further detail

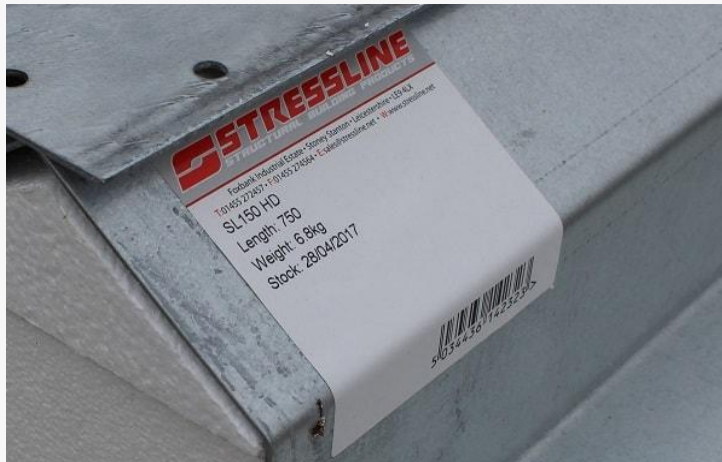
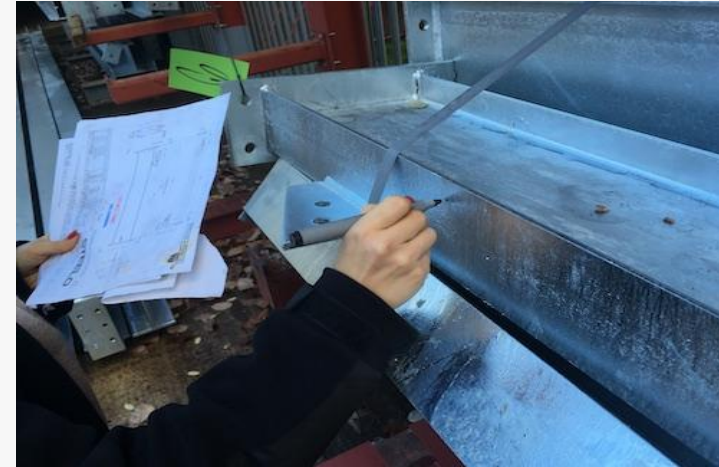

# Common Methods of Beam Marking



## Hand Writing

- X Recognizable?
- X Dirty?
- X Scratched off?



## Tool Scripting

- X Recognizable?
- X Dirty?
- X Scratched off?



## Branding

- X Recognizable?
- X Dirty?
- X Labouring?



## Label Sticker

- X Dirty?
- X Scratched off?
- X Worn off?

# Advanced GDM ID Tag



- Dim: 90 \* 35 mm
- Material: steel.01

Available in :

- ✓ **Blank**
- ✓ **Letter/Number**
- ✓ **QR Code**



# GDM ID Tag



- Made by advanced GDM stamping machine.
- Packed per customer's demand.

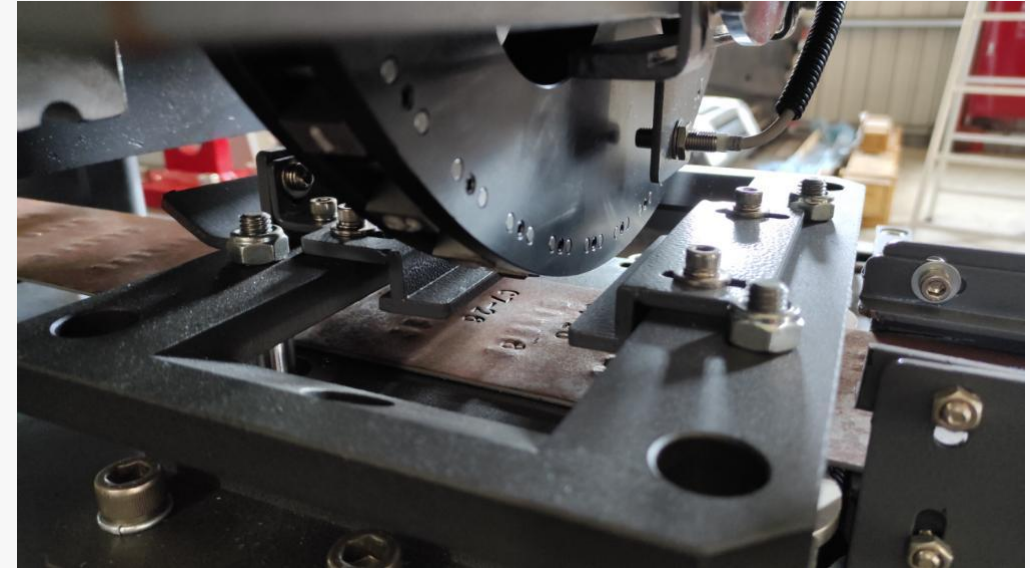

# GDM QR Coded ID Tag



- Made by advanced GDM stamping machine.
- Clear & hard stamping on a steel plate.
- Readable even dirty .

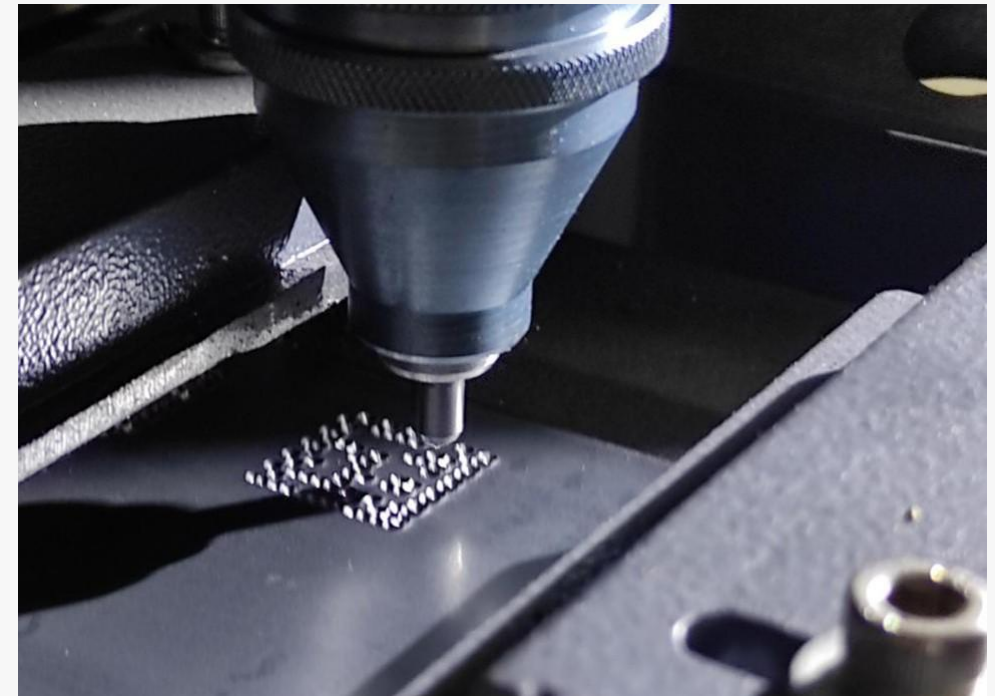



**B**

**GD - PDM**



# Advantages of GD-PDM



- APP available with IOS or Android.
- Copping with GDM QR Code ID tags.
- Easy to trace material on the work floor.
- Linked to mass data base for necessary info.



# Advantages of GD-PDM

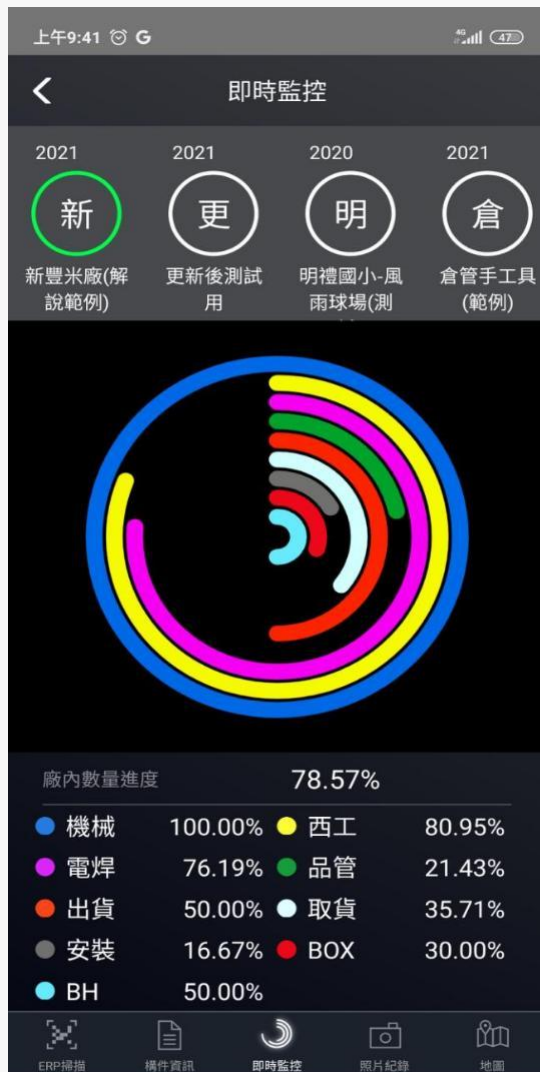

Real-time work flow



Material Data Tracking

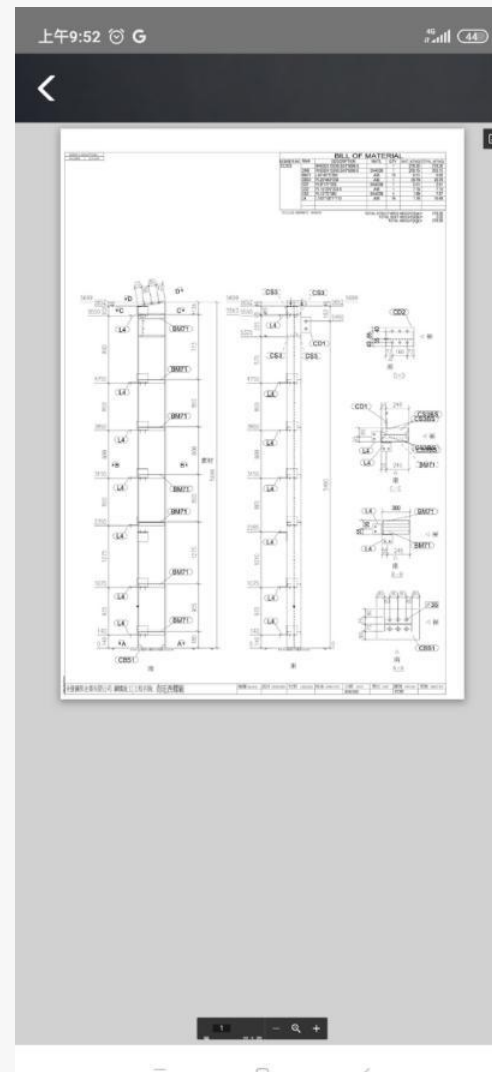

Drawing Reference

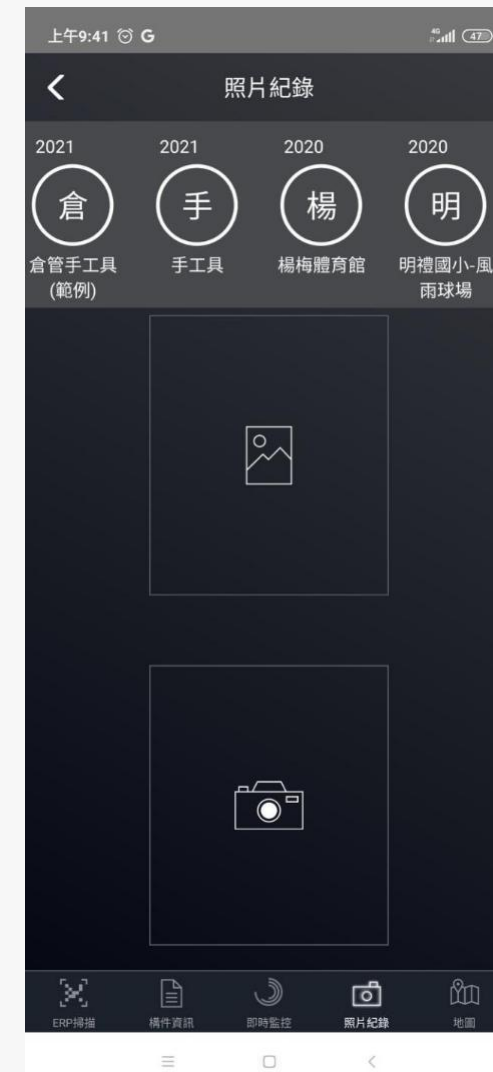

Multi Projects Management



**GDM**  
**Tag Stamping Machine**

# All-In-One Solution



# All-In-One Solution



Steel Band Feeder

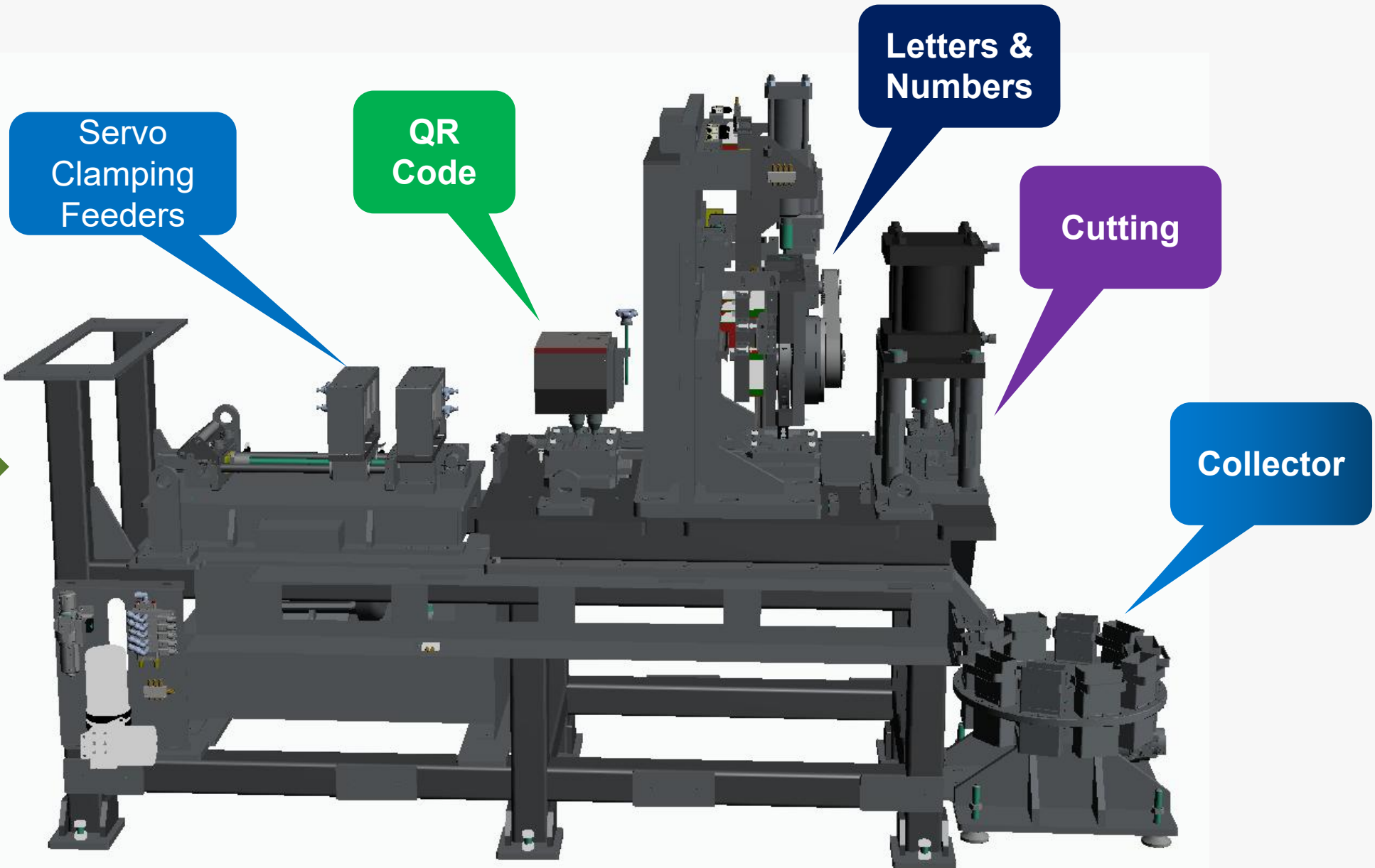

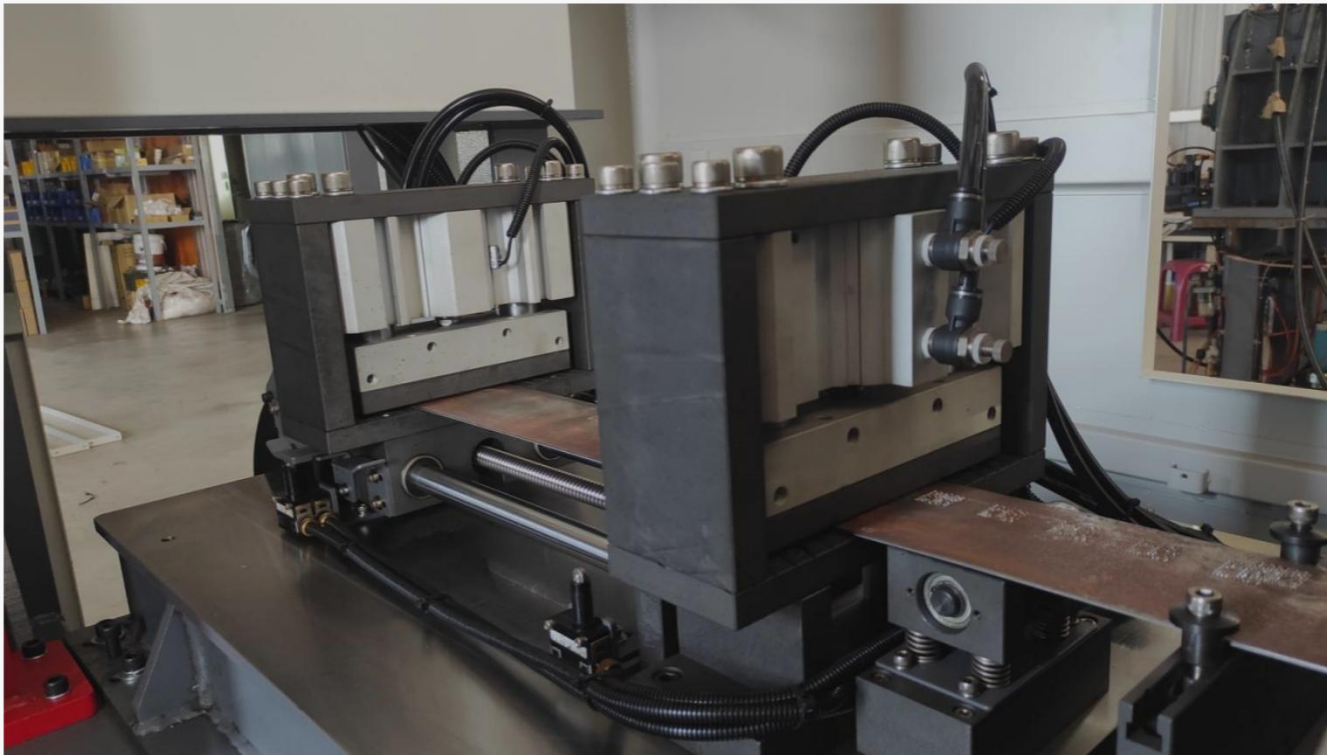

## Dual Servo Clamping Feeders

Controlled by servo motor

- to ensure a good stamping quality
- to control the feeding rate

# QR Code



GDM designed QR Code Stamping set

**Fast / Clear / Reliable / No Waste**



# Letters & Numbers



Servo-Driven Magazine

Bi-Direction & Shortest Path

**Fast / Clear / Reliable / No Waste**

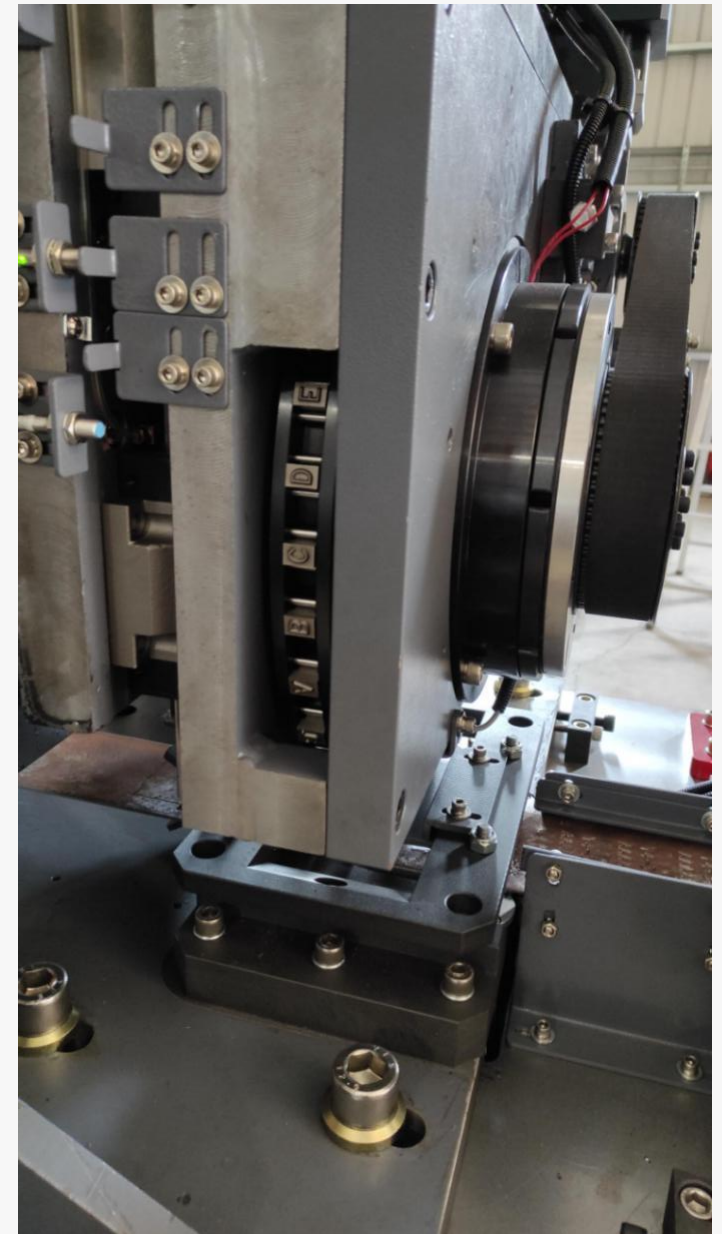
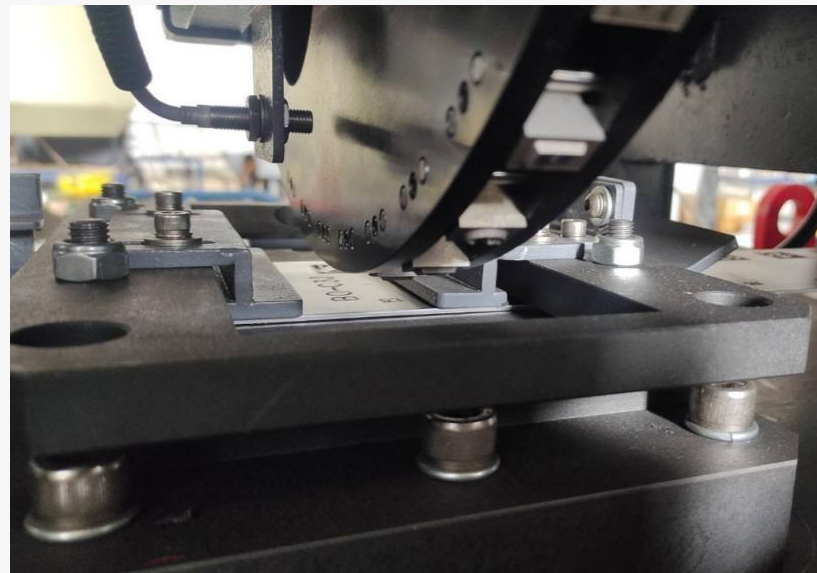





Hydraulic Controlled Stamping

**Fast / Heavy Duty / Reliable**



# Cutting



Hydraulic Punch Cutter

**Fast / Reliable / Clean Cut**

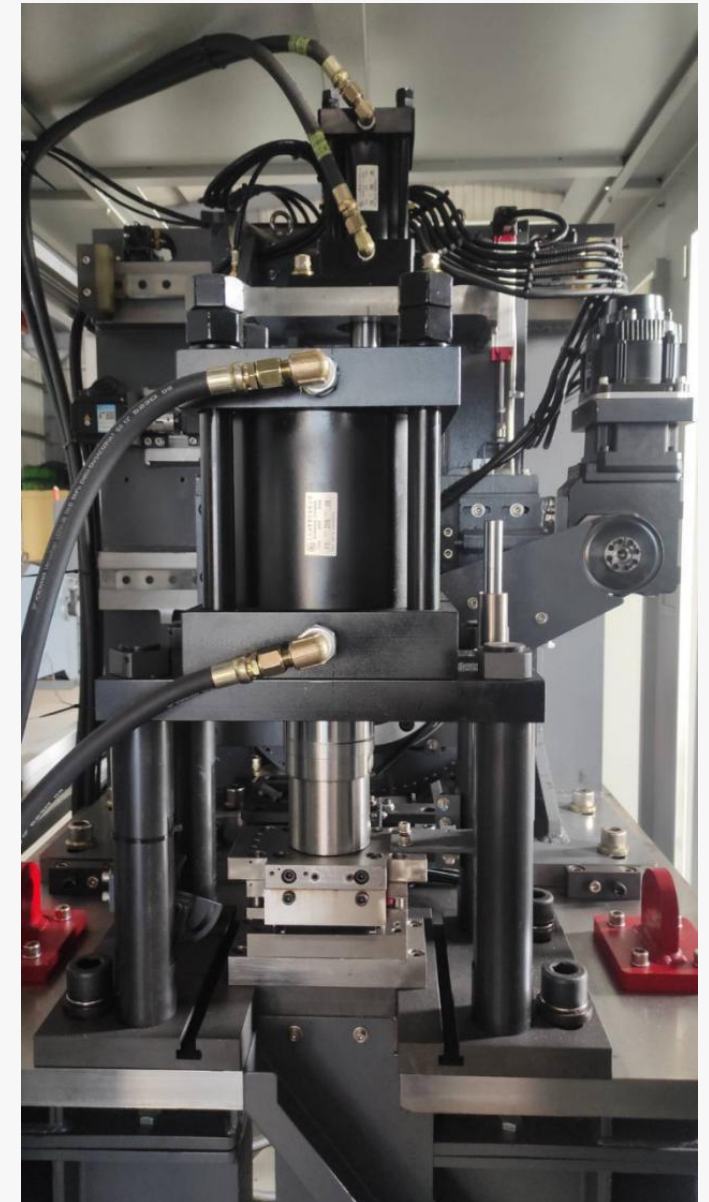
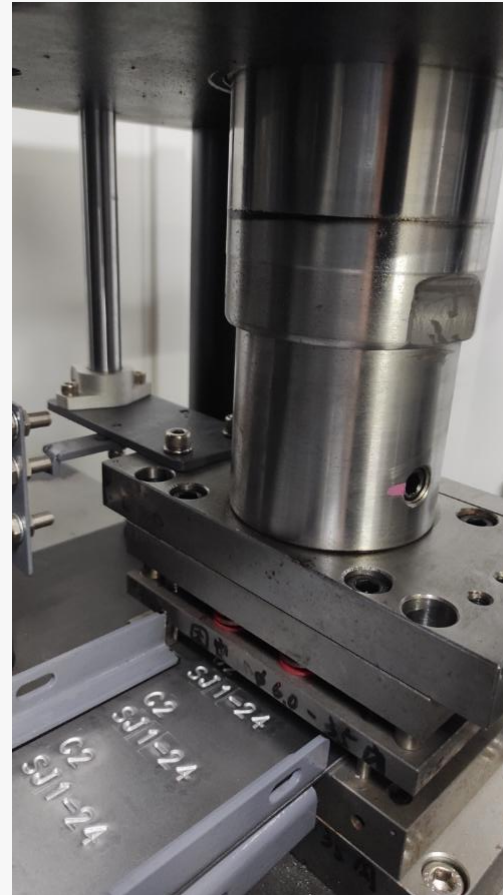

Automatically Sorting Tag/Waste

**Convenient / Clean**



Easy for setting and cleaning.

Extendable thru-conveyor for a more convenient collecting.

**Convenient / Accessible**



# Control Panel



Swivel Control Panel

=> Convenient for job settings.

Flip Keyboard Storage

Tool Drawer

**Convenient**

**Clean Working Floor**



# Real Time Work Flow



Clear display of work flow on 19" monitor.

Instant work-flow control.



# Band Feeder -- Optional



Copping with Tag Stamping Machine

**Fully Automation for long-hour continuous operation.**



# Thank You!



**GUANDA**  
Machinery

Wuri, Taichung City, Taiwan

TEL: +886-4- 2335 7282