

砲塔型立式銑床



千誠機械股份有限公司
CHIEN CHENS MACHINERY CO., LTD.



台灣桃園市中壢區福星六街60之2號

No. 60-2, Fu Hsing 6th St., Chung Li Dist., Tao Yuan City, Taiwan

Tel: 886-3-462-6421

Fax: 886-3-462-7645

E-mail: chienchens@hotmail.com.tw <http://www.chienchens.com.tw>

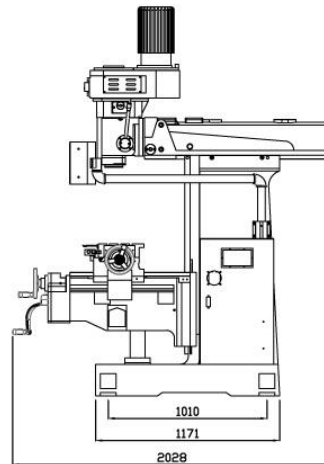
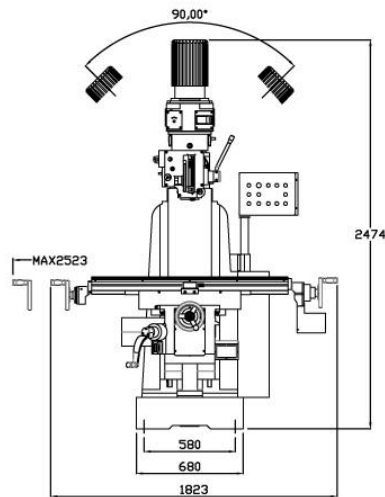

機械規格/Specification		OX-700VS	
主軸 Main Spindle	迴轉速度 (立銑無段變頻)	Spindle speed (non step inverter)	60~4000rpm
	左右傾斜角度	Swive angle of head	45° (R&L)
	伸出臂行程	Overarm travel	550mm
	主軸砲管行程	Quill travel	140mm
	主軸砲管直徑	Quill diameter	115mm
	主軸端至工作台面距離	Distance of spinde to table	120~520mm
	主軸中心至機身距離	Distance of spindle to colum surface	140~750mm
	主軸自動押送速度(每轉一圈)	Quill feed per revolution of spindle	0.035/0.07/0.14mm
工作台 Table	工作台尺寸 (長x寬)	Working table area (LxW)	1250 x 290mm
	左右行程	Longitudinal travel manual/auto	700mm
	前後行程	Cross travel	400mm
	昇降行程	Vertical travel of knee	400mm
	T形槽 (寬x槽數x間距)	T-slots	16 x 3 x 72mm
	X.Y進給速度	Cutting feedrate (X.Y)	0~3000mm/min
	昇降進給速度	Feeding speed	1150mm/min
電動機 Motor	立主軸AC變頻馬達	Main spindle-AC inverter	3.7kw (5HP)
	X.Y伺服馬達&昇降座	X.Y servo motor & Table elevating	X, Y=0.6kw, Z=0.75kw
	潤滑泵浦	Lubricating pump	150W
	電磁泵浦	Electromagnetic pump	40W
機械重量及包裝 Machine Weight & Packing	外觀尺寸	Machine measurement (LxWxH)	2100 x 1820 x 2460mm
	裝箱尺寸	Packing measurement (LxWxH)	1425 x 2300 x 2200mm
	淨重	Net weight	1920kgs
	毛重	Gross weight	2070kgs

標準配件：

- 工具箱
- LED工作燈
- 手動拉桿
- 主軸簡易攻牙裝置
- Y軸前伸縮護罩
- X.Y滾珠導桿
- 百分表座

Standard Accessories:

- Tool box and tools
- LED Working light
- Draw bar. (manual)
- Tapping equipment of spindle
- Trackable chip cover on Y axis
- X.Y axis ball screw
- Indicator

特殊配件：

- 光學尺
- 氣動鎖刀
- 冷卻系統含水盤
- 壓克力護罩

Optional Equipment:

- DRO
- Power drawbar
- Coolant system
- Acrylic cover



千誠機械股份有限公司
CHIEN CHENS MACHINERY CO., LTD.
www.chienchens.com.tw