



ST-3500

**3.5KW Induction Machine and
Water Cooling Station**

3.5KW 電磁感應加熱水冷機組



3.5KW Induction Machine and Water Cooling Station

3.5KW 電磁感應加熱水冷機組



ST-3500



ST-3500 eco

Features 產品特點

1. Generate an alternating electromagnetic field by using 3.5KW high-frequency thermal coil. Refer to the heating time sheet, it's easy to load and unload tools just need to set the diameter and heating seconds.
2. Prolong holder life by using low-powered heating and water cooling.
3. By water-cooling with coolant, it can clean most of carbon deposits and prevent the chuck become rusty.
4. Use with Speed Tiger Shrink Fit Chucks and Power Tips Series, will show the maximum performance and economic benefits of shrink system.
5. Combine 2 functions in 1 machine: Operate heating and cooling process at one machine, i.e. no need to remove the base. Operating time within 1 minute and use friendly.

1. 採用3.5KW功率進行中週波調變，產生交流磁場，進行感應加熱。可使用內建參數表或自訂秒數進行加熱。
2. 低功率加熱，可延長刀桿壽命。更可直接淋浴式水冷。
3. 利用水冷卻方式，搭配專用冷卻劑，進而清除大部分積碳，更有效抑制刀桿生鏽。
4. 本設備搭配使用震虎燒結刀桿與斬露頭角系列產品，更可展現出燒結系統最大效益。
5. 本機採用一體式設計，燒結冷卻同一機上作業，操作方便可在一分鐘內完成作業。

Specifications 機台規格	ST-3500	ST-3500 eco
Power 功率	3.5KW	
Voltage 電壓	1ø220V 15A	
Tools 適用刀具	Solid Carbide 鎢鋼	
Tool diameter 適用刀具直徑	3~32mm	
Maximum length of shrink fit chuck 最大熱縮刀柄長度	300mm	
Dimensions 機器尺寸	(W)600x(L)480x(H)777 mm	(W)410x(L)480x(H)777 mm
Weight 機器重量	80Kg	40Kg

3.5KW Induction Machine and Water Cooling Station 3.5KW 電磁感應加熱水冷機組

Standard Equipment 標準配件

Induction Unit Toolholder Base / 刀桿基座

CODE 型號	W 重量 (KG)	(Q'TY) 內含數量	ST3500	ST3500 eco
EZ BASE NO40(FIT BT40, SK40 & CAT40) (適合 BT40, SK40 & CAT40 刀桿)	1.00	1PC/ 1 個	V	V

Standard Equipment include ONE piece "Toolholder base". We provide various spec. for choosing. If no specified, it will be included tool holder base fit BT40.
標準配備內含一個刀桿基座，多種規格任您挑選。
若無特別註明，則搭配 BT40 刀桿基座。



Heat Resist Gloves / 耐熱手套

CODE 型號	W 重量 (KG)	(Q'TY) 內含數量	ST3500	ST3500 eco
HEAT RESIST GLOVES 耐熱手套	0.08	1PC/ 1 個	V	



Round Tray / 熱膨脹燒結刀桿用刀具圓形放置盤

CODE 型號	W 重量 (KG)	(Q'TY) 內含數量	ST3500	ST3500 eco
EZ ROUND TRAY 熱膨脹燒結刀桿用刀具圓形放置盤	0.50	1PC/ 1 個	V	

Suitable for EZ BASE Sxx 適用任何規格之刀桿基座



Shower House / 冷卻雨淋上蓋

CODE 型號	W 重量 (KG)	(Q'TY) 內含數量	ST3500	ST3500 eco
EZ3W SHOWER HOUSE (A) EZ3W 冷卻雨淋上蓋 (A)	1.40	1PC/ 1 個	V	
EZ3W SHOWER HOUSE EXTENSION (B) EZ3W 冷卻雨淋上蓋 (B)	0.40	1PC/ 1 個	V	



(A) (B)

Has been installed on ST3500 已裝在機上

Coolant Liquid / 冷卻劑

CODE 型號	W 重量 (KG)	(Q'TY) 內含數量	ST3500	ST3500 eco
EZ3W COOLANT LIQUID 600ML 冷卻劑 600 毫升	0.60	1PC/1 個	V	

EZ3W COOLANT LIQUID 600ML is for the whole tank of shower station. Use coolant liquid same as grinding machine. Recommend coolant liquid Castrol Syntilo 9930, and replace coolant liquid for all tank at every 6~12 months.
冷卻液 600 毫升剛好供冷卻水槽使用，EZ3W 冷卻液使用水溶性切削研磨液。
建議使用 Castrol Syntilo 9930 水溶性切削研磨液，並每 6~12 月更換水槽冷卻液。



Tool Set / 工具組 0.4KG / SET

CODE 型號	(Q'TY) 內含數量	ST3500	ST3500 eco
A. Power Plug Adapter 轉換插頭	1PC/1 個	V	V
B. Heating Sleeve 導熱套筒	1PC/1 個	V	
C. Filter 濾網	1PC/1 個	V	
D. Stainless Steel Ruler 150mm 不鏽鋼尺	1PC/1 個	V	
E. Long Nose Plier 尖嘴鉗	1PC/1 個	V	
F. Slip Joint Plier 鯉魚鉗	1PC/1 個	V	
G. Hex Wrench SET 六角扳手組	1SET/ 1 組	V	



B Heating Sleeve 導熱套筒

3.5KW Induction Machine and Water Cooling Station 3.5KW 電磁感應加熱水冷機組

Optional Equipment 選擇配件

Toolholder Base / 刀桿基座

STOCK 庫存	CODE 型號		W 重量 (KG)
◎	EZ BASE NO20	(FIT ISO20 & ISO20G)	1.00
◎	EZ BASE NO25	(FIT ISO25 & ISO25G)	1.00
◎	EZ BASE NO30	(FIT BT30 & BT30G)	1.00
◎	EZ BASE NO40	(FIT BT40, SK40 & CAT40)	1.00
◎	EZ BASE NO50	(FIT BT50, SK50 & CAT50)	1.00
◎	EZ BASE H025	(FIT HSK025)	1.00
◎	EZ BASE H032	(FIT HSK032, PSC032 & TS032)	1.00
◎	EZ BASE H040	(FIT HSK040, PSC040 & TS040)	1.00
◎	EZ BASE H050	(FIT HSK050, PSC050 & TS050)	1.00
◎	EZ BASE H063	(FIT HSK050, PSC050 & TS050)	1.00
◎	EZ BASE H080	(FIT HSK080, PSC080 & TS080)	1.00
◎	EZ BASE H100	(FIT HSK100, PSC100 & TS100)	1.00



Toolholder Extension Base / 刀桿延長桿基座

STOCK 庫存	CODE 型號		W 重量 (KG)
◎	EZ BASE S10		0.30
◎	EZ BASE S12		0.30
◎	EZ BASE S16		0.35
◎	EZ BASE S20		0.35
◎	EZ BASE S25		0.30
◎	EZ BASE S32		0.30
◎	EZ BASE SU03 3/8"		0.30
◎	EZ BASE SU04 1/2"		0.30
◎	EZ BASE SU05 5/8"		0.35
◎	EZ BASE SU06 3/4"		0.35
◎	EZ BASE SU10 1"		0.30
◎	EZ BASE SU12 1 1/4"		0.35



Toolholder Extension Base
刀桿延長桿基座



BT40 Toolholder Base
BT40 刀桿基座

Needs EZ BASE NO40 or EZ ROUND TRAY to operate
需要搭配 EZ BASE NO40 或 熱膨脹燒結刀桿用刀具圓形盤放置一起使用

Extension for BT50 toolholder base / BT50 刀桿基座擴充配件

STOCK 庫存	CODE 型號		W 重量 (KG)
	BT30 Round Tray	BT30 刀桿隔環	0.60
	BT40 Round Tray	BT40 刀桿隔環	0.60
	HSK30 Round Tray	HSK30 刀桿隔環	0.60
	HSK40 Round Tray	HSK40 刀桿隔環	0.60
	HSK50 Round Tray	HSK50 刀桿隔環	0.60

BT50 toolholder base uses with these Round Tray, and then it can apply to BT30/BT40/HSK30/HSK40/HSK50 toolholder.

若您是選購 BT50 刀桿基座，搭配上隔環，即可適用 BT30/BT40/HSK30/HSK40/HSK50 刀桿。

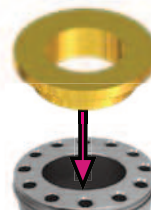

Round Tray
刀桿隔環



BT50 Toolholder Base
BT50 刀桿基座

STOCK ◎ = 標準在庫品 // STOCK ○ = regular stock



For further information of ST-3500 operation, please refer to below QR code.

若欲進一步了解 ST-3500 電磁感應加熱水冷機組操作方式，請參閱以下 QR code.

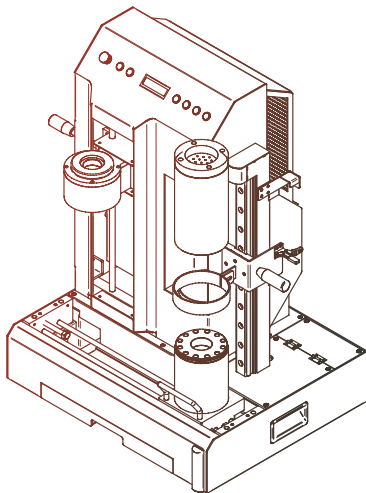
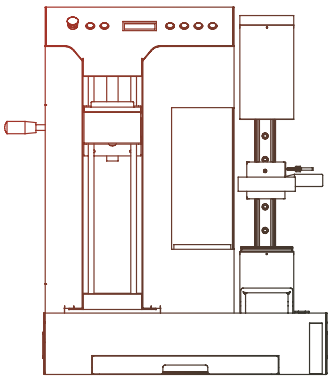

- Introduction
產品介紹
- Standard Mode Operation
標準模式操作說明
 - Insert the tool
燒結刀具
 - Take out the tool
取出刀具操作
- Custom Mode Operation
自選模式操作說明
- Heating Sleeve Instruction
導熱套筒使用說明
- Shrink Fit Program for Dual End Set
雙頭龍燒結操作說明
 - Insert the tool
燒結刀具
 - Take out the tool
取出刀具
- Heating Second Reference
燒結時間參考表

Operation Manual Download
操作手冊下載



ST3500
Operation Video-English



ST3500
操作影片(中文)

