



**VERTICAL MACHINING CENTER**  
Compact, Durable, Powerful,  
Strong and Accurate



[sales@microdynamicsfa.com](mailto:sales@microdynamicsfa.com)  
[www.microdynamicsfa.com](http://www.microdynamicsfa.com)



MD202307E



**MEGA  
TERA** SERIES

# VERTICAL MACHINING CENTER

# MEGA TERA SERIES



<b>SPINDLE SPEED</b>	15,000 rpm	18,000 rpm (opt.)	20,000 rpm (opt.)
<b>SPINDLE POWER<sup>(*)</sup></b>	31 kW	31 kW	35 kW
<b>RAPID TRAVERSE</b>	52 m/min		
<b>TOOL TO TOOL</b>	1.2 sec		
<b>LOOK AHEAD</b>	2,700 block		

<sup>(\*)</sup> Peak based on 25% Duty Cycle.

Micro Dynamics Vertical Machining Center Line opens a new era in multi-purpose and versatile machining centers. Compact, durable, powerful, strong and accurate, the **MEGA/TERA Series** starts a revolution in the market: the smallest C-frame machines provide powerful and precise results for manufacturers of dies and molds, aerospace, automotive, semi-conductor, job shops and general machine sectors.

The **MEGA/TERA Series** has been designed with the latest in technology being utilized throughout the machine with productivity in mind. From its EtherNet/IP architecture for easy automation and integration into systems and cells, to its Motion Control for fast and smooth operations used in all industries, the **MEGA/TERA Series** has quickly become one of the industries leading machine tool lines of Vertical Machining Centers.

### POWERFUL

integrated Micro Dynamics® Built-in Spindle.

### THERMAL COMPENSATION

DYPEC® - Dynamic Predictive Error Compensation.

### COMPACT

design with small footprint.

### COLLISION DETECTION

machine stops if a collision is detected in all axis.

### FAST

Mitsubishi CNC M830VW.

### MICRO MILL®

G-code Generator

### STRONG

FC300 Meehanite® casting.

### RIGID TAP

up to 6,000 rpm.

### RELIABLE

highest quality mechanical and electrical components.

### PC BASED HMI

allows user friendly functions.

### INTEGRATED AUTOMATION

EtherNet/IP networked I/O.

### 15" TOUCHSCREEN

ergonomically friendly.

# BUILT-IN SPINDLE

All Micro Dynamics spindles are built with all shelf standard bearings which can be replaced without removing the rotor. This makes all machines simple and fast to maintain. Rebuild costs are very low due to the availability of the parts and the short service time.

- Powerful integrated 40 taper dual contact spindle.
- Maintenance free 15,000 rpm ~18,000 rpm spindle requires no added oil or grease.
- ATE® motor integrated with hybrid ceramic angular contact bearings.
- Micro Dynamics drawbar has been rigorously tested to sustain more than 2 million cycles.
- For all applications, from heavy duty to high speed machining.
- Highest productivity under any conditions and complexities.
- CTS (Coolant Through Spindle) designed to sustain up to 100 bar (1,500 psi).(\*)

**15,000 rpm**

(40 Taper Dual Contact)



**18,000 rpm (opt.)**

(40 Taper Dual Contact)



**20,000 rpm (opt.)**

(40 Taper Dual Contact)



Micro Dynamics optional 20,000 rpm spindle, available on all models, delivers 35 kW of power and 119 Nm of torque. This allows for fine finishes while still achieving high material removal rates in a wide range of material types.

The **MEGA/TERA Series** has been refined through years of research and development of new technologies that greatly enhance the machines for the rigors of the Mold and Die industry.

- Advanced Motion Control technology that benefits the production of Mold and Die components.
- Highest Quality components to ensure fast and smooth cutting strategies.
- 4G SSS (G05P20000) Motion Control processing speed of up to 270,000 blocks per minute.
- DYPEC® - Thermal Compensation. Real time thermal growth compensation, monitoring every few milliseconds, with 0.1 microns compensations to ensure accuracies during long cycle times.

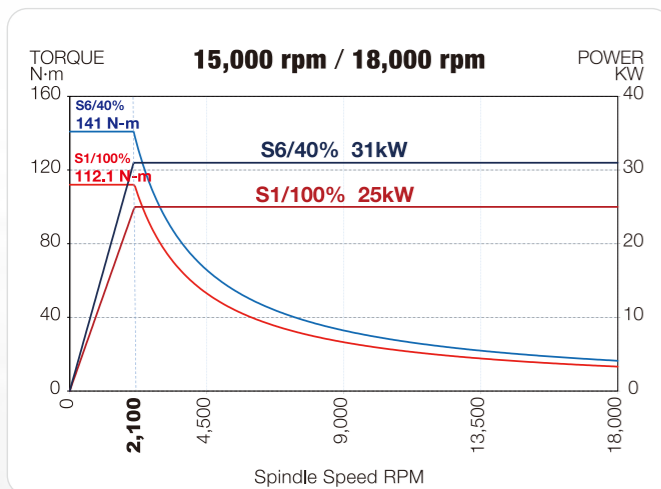

**31 kW** Power

**1.5 sec** Acc. 0 – 12K

**141 Nm** Torque

**1.8 sec** Dec. 12K – 0

(\*) CTS preparation is standard equipment. CTS system is optional.

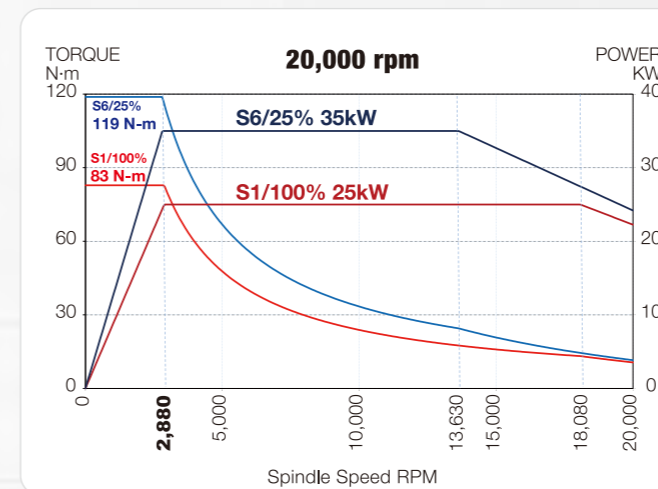

**35 kW** Power

**1.5 sec** Acc. 0 – 12K

**119 Nm** Torque

**1.8 sec** Dec. 12K – 0



# AUTOMATIC TOOL CHANGER

The **MEGA/TERA Series** is equipped with a high-speed double arm tool changer with a 40-tool magazine<sup>(\*)</sup>. The magazine is integrated on the machine with an isolated structure, eliminating vibrations to the column, thus improving accuracy and finishes. The multi speed double arm allows the operator to adjust the speed of the tool changes for oversized, heavy tools and probes, to ensure accuracy and reliability. The ATC recovery function in HMI is a standard feature that assists the operator in recovering the position of the arm and the tool.

<sup>(\*)</sup> MEGA 30V standard is 30-tool magazine.

## ATC SPEED:

**1.2 sec** Tool to Tool

**2.5 sec** Chip to Chip

Factory Conditions

**ISOLATED STRUCTURE**

## FULL COVER MAGAZINE

The tool magazine is protected from the machining environment reducing chips and coolant from entering the magazine area.

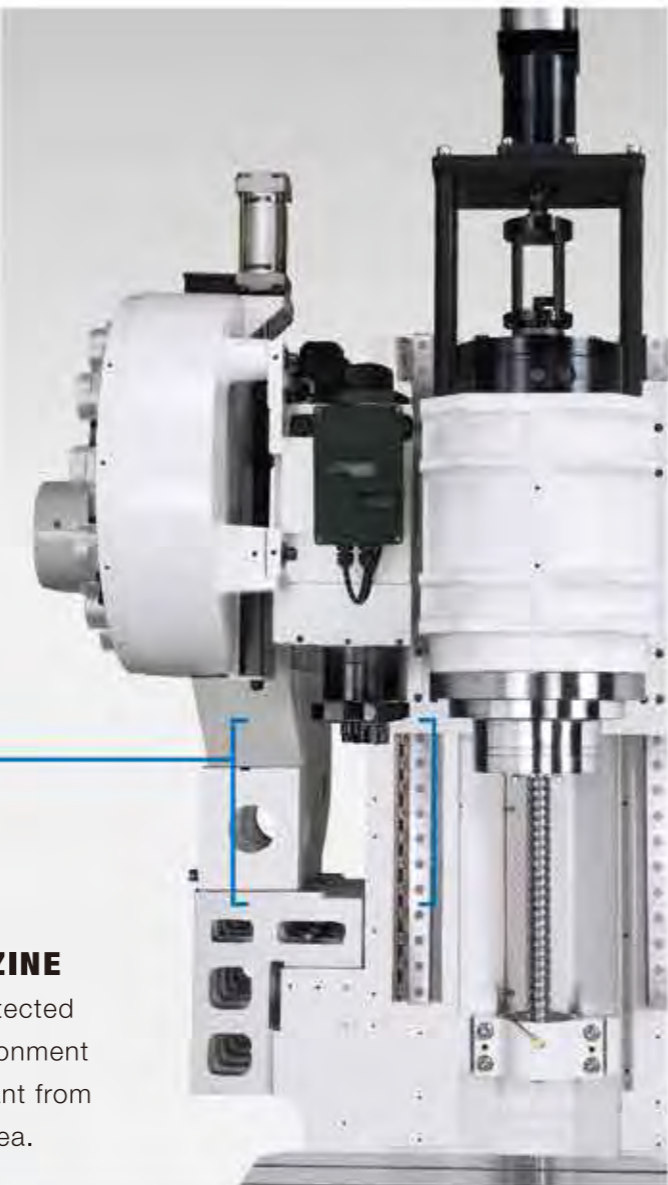

ATC REAR OPERATION PANEL<sup>(\*)</sup> and door allow access for loading, unloading and inspection of tools while the machine is in operation. Tools can be called up either by tool number or by pocket number. During manual operation the machine will continue the cycle without interruption until ATC door is closed and the key is switched to automatic.

<sup>(\*)</sup> Except MEGA 30V.

# CHIP MANAGEMENT SYSTEM



The chip management system includes base wash, dual augers and chip conveyor, virtually eliminating chip build-up. Coolant falls along the inside perimeter flushing chips down to the dual augers which evacuate chips to the front conveyor. All mounting hardware is bolted from the outside leaving a clean surface for chip evacuation.



Triple protection on linear guides and ball screws: bottom cover, top cover and telescopic cover.



## MODULAR COOLANT/CHIP SYSTEM

- |                       |                    |
|-----------------------|--------------------|
| 1. Filter Chip Basket | 4. CTS Pump Option |
| 2. Filter Chip Pan    | 5. Base Wash Pump  |
| 3. Chip Conveyor      | 6. Coolant Pump    |



## REVERSIBLE CONVEYOR

standard in all MEGA/TERA Series. Rear chip conveyor available under request.

# ERGONOMICS

**MEGA/TERA Series** is ergonomically designed for operator and maintenance convenience. The large wide front door can be opened with one hand. There are three LED lights, two in the sides and one over the work area.

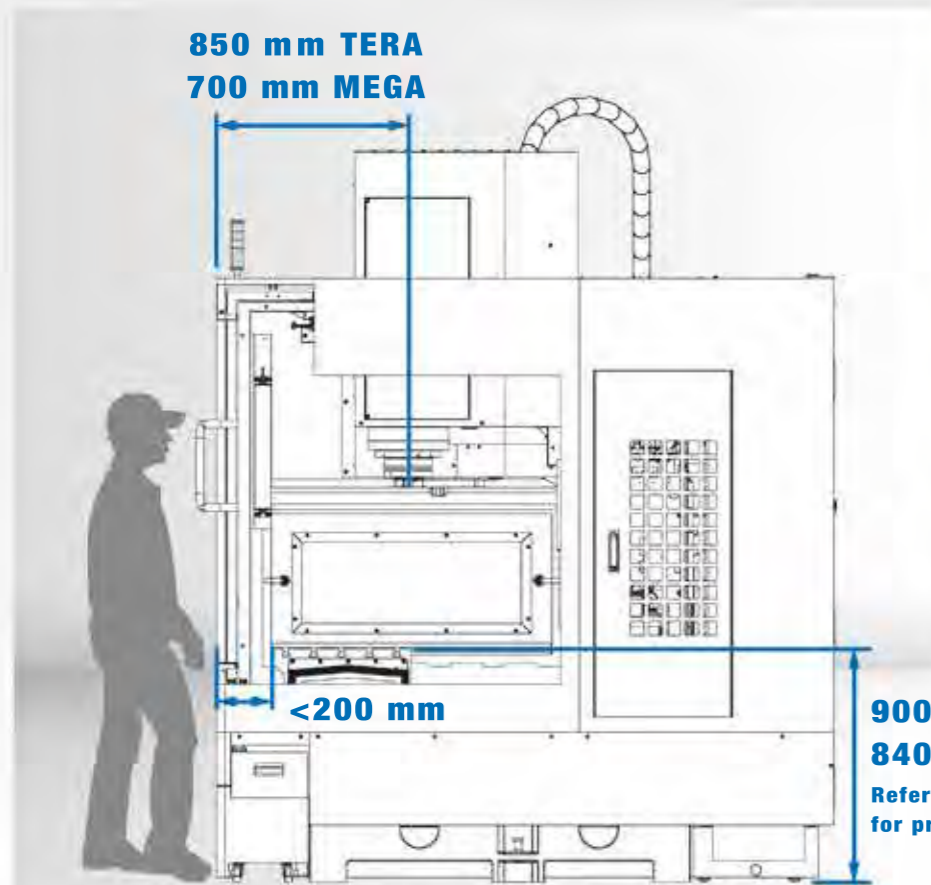

Headstock service door to facilitate access is standard on all models.

The distance from the door to the table is less than 200 mm for easy setup and part loading. The reach for operator access to the spindle is greatly reduced.

Two axes motion operator panel offers flat, tilting and swivel control.



# DYPEC<sup>®</sup> THERMAL COMPENSATION

**DYPEC<sup>®</sup>, Dynamic Predictive Error Compensation,** corrects position error caused by thermal changes which improves accuracy and part finishes (resolution 0.1 μm).



DYPEC<sup>®</sup> software chart in HMI



DYPEC<sup>®</sup> mirror milling with ball end mill



 **THERMAL SENSOR**

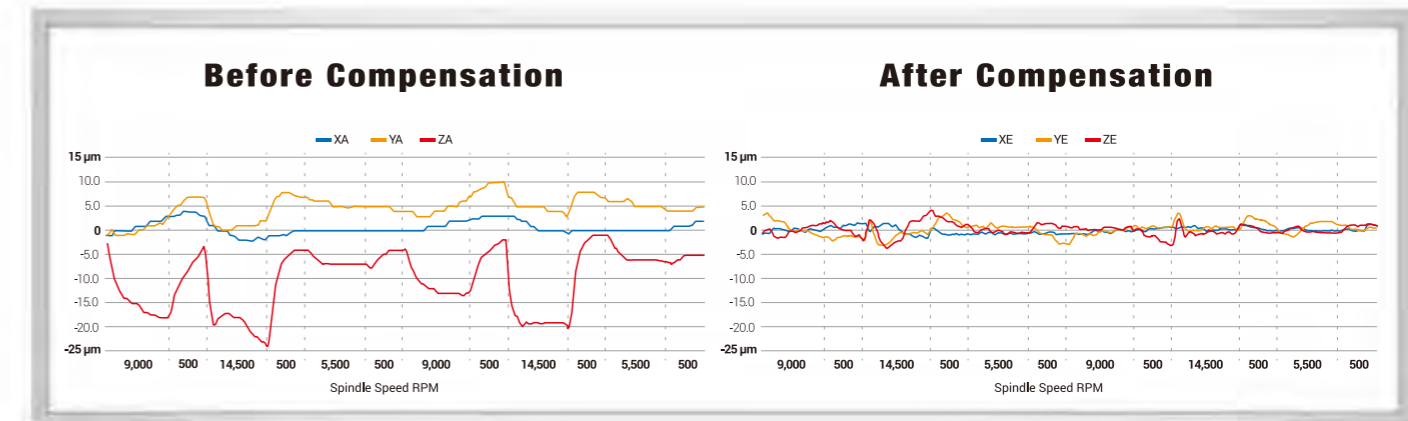

X/Y/Z axis static error in micron before and after DYPEC<sup>®</sup> compensation (48 hours test).

# MICRO DYNAMICS® HMI

The Windows® embedded HMI CNC gives the user the ability to create or add apps to make it flexible to operate and automate the machine. Operator can load, run or edit any program from any device: internal HMI memory, PC hard drive or external USB device.

The **MEGA/TERA Series** features Mitsubishi CNC M830VW Control which is well suited to high-speed, high-accuracy machining and multi-axis, multi-part system control. Mitsubishi's tool path graphics verification makes it easier for end users to check G-Code program before machining.



## COLLISION DETECTION

Machine stops if a collision is detected in all axis.



## AUTO PART SETUP

X, Y, Z work offset can be achieved with a hard probe.



## MICRO MILL®

is an interface that allows any operator to easily perform milling and drilling operations while creating G-Code and post to MDI or main memory.



## PART SETUP



## TOOL SETUP



## PARAMETER SETUP



## MAGAZINE MONITOR



## ATC RECOVERY

function allows the operator to recover the tool changer.



## APC RECOVERY

function allows the operator to recover the pallet changer.

### Micro Dynamics® features:

- Mitsubishi CNC M830VW series.
- 15" Touchscreen display.
- 2,700 Block Look Ahead.
- 20 GB Data Server.
- 1,000 Programs in editing memory.
- 999 Sets in tool compensation.
- DXF import.
- 54 Sets work offsets.
- 400 Sets tool life management.
- 8,000 Sets macro variable.
- 64 Bit microprocessor.
- 2,048 KB Program memory.
- Main and subprograms can be edited and run as one file.
- Programs can be run from the front side USB or the hard drive.
- 3D circular interpolation.
- G-Code guidance.
- Helical interpolation.
- NURBS interpolation.\*
- Programmable in-position check.
- Scaling.
- Simple programming (NAVI mill conversational programming).
- 4G SSS Control (Super Smooth Surface).
- Tolerance control.
- Spiral/conical interpolation.
- Tool Center Point Control.
- 3D tool radius compensation.
- Workpiece position offset for rotary axis.
- Inverse time feed.
- Polar coordinate command.
- Upgradable to 5 axes simultaneous control.\*

(\* Optional for U.S. market only.)

# MEGA 20VAPC



**SERVO DRIVEN  
PALLET CHANGER**

Dual pallet changer MEGA 20VAPC is designed for high production. The servo driven pallet changer switches tables in 8.5 sec. With the APC recovery function in the HMI the operator can easily perform maintenance of the pallet changer.



Pressurized cones



# MEGA 30VT / TERA 50VT



The MEGA 30VT and TERA 50VT are Micro Dynamics's five-axis trunnion (4+1) table machines with hydraulic brakes. The design allows the user to load three vises or can be used as a 500 x 300 mm work table with a 220 mm diameter face plate<sup>(\*)</sup> in MEGA 30VT and 720 x 400 mm work table with a 320 mm diameter face plate<sup>(\*\*)</sup> in TERA 50VT.

For automation the through hole of the rotary table allows for the plumbing of hydraulics, pneumatics or other devices. A true five-axis simultaneous version is available as an option.



**MACHINE 6 SIDES IN ONE LOAD**

- Left vise: cut dove tail.
- Central vise: 5-side machining.
- Right vise: finish dove tail.



40° ~ -120°

360°

Titling axis and Rotary axis motion ranges.



630 mm

- (\*) **MEGA 30VT: 300 mm and 350 mm** diameter face table. (opt.)
- (\*\*) **TERA 50VT: 500 mm and 630 mm** diameter face table. (opt.)



# MACHINING CAPACITY

## FACE MILL



**MATERIAL REMOVAL:**  
**766 cc/min**

**SPINDLE LOAD:**  
**87%**

- Tool: **63 mm Face Mill**
- Material: 1050 Steel
- Cut: 50 mm x 6mm
- Feedrate: 2,533 mm/min
- Spindle Speed: 2,173 rpm

## END MILL



**MATERIAL REMOVAL:**  
**368 cc/min**

**SPINDLE LOAD:**  
**47%**

- Tool: **32 mm End Mill**
- Material: 1050 Steel
- Cut: 32 x 5 mm
- Feedrate: 2,300 mm/min
- Spindle Speed: 3,800 rpm

## DRILL



**MATERIAL REMOVAL:**  
**834 cc/min**

**SPINDLE LOAD:**  
**90%**

- Tool: **45 mm Drill**
- Material: 1050 Steel
- Diameter Cut: 45 mm
- Cutting Depth: 35 mm
- Feedrate: 530 mm/min
- Spindle Speed: 2,100 rpm

## TAP



**SPINDLE LOAD:**  
**46%**

- Tool: **33 x 3 mm Tap**
- Material: 1050 Steel
- Feedrate: 348 mm/min
- Spindle Speed: 128 rpm

Factory Conditions

## FACTORY TEST

Micro Dynamics standard factory tests for all models includes the circle, diamond, square cutting test, as well as milling, drilling, tapping and the heavy milling test based on below parameters:

- Tool: 50 mm End Mill
- Material: 1050 Steel
- Cutting Width: 22 mm
- Cutting Depth: 7 mm
- Feedrate: 700 mm/min
- Spindle Speed: 1,100 rpm
- Load: 40%



# ACCURACY



Micro Dynamics circle, diamond, square cutting test is done on all machines prior to shipment at 1,500 mm/min with a maximum tolerance under 5 microns linear.

- XY, XZ and YZ Double Ball Bar Test Results at 1,500 mm/min under 5 microns.
- X, Y and Z Axis Laser Compensation under 5 microns.
- 4th and 5th Axis Laser Compensation under  $\pm 10$  arcsecs.



E.g. XY Double Ball Bar Test Results under 5 microns.

16% Squareness	6.3 $\mu\text{m}/\text{m}$
16% Backlash X	$\leftarrow -0.3 \mu\text{m}$ $\rightarrow 0.9 \mu\text{m}$
13% Reversal spikes X	$\leftarrow -0.8 \mu\text{m}$ $\rightarrow -0.4 \mu\text{m}$
12% Cyclic error Y	$\uparrow 0.8 \mu\text{m}$ $\downarrow 0.7 \mu\text{m}$
10% Lateral play X	$\leftarrow 0.8 \mu\text{m}$ $\rightarrow 0.4 \mu\text{m}$

Circularity **2.7  $\mu\text{m}$**  **Factory Conditions**

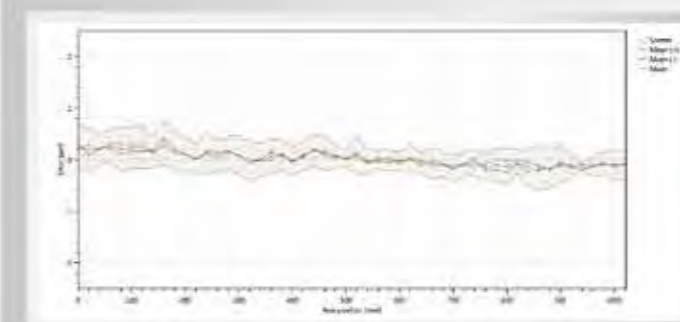

E.g. X Axis Laser Compensation under 5 microns.

Linear X - Analysis features VDI 3441	
Name	Value ( $\mu\text{m}$ )
Maximum reversal (U max)	0.2
Maximum scatter (Ps max)	0.8
Positional uncertainty (P)	<b>1.4</b>
Positional deviation (Pa)	0.5
Mean reversal	0.1
Mean scatter (Ps mean)	0.5

(Without scales)

**Factory Conditions**

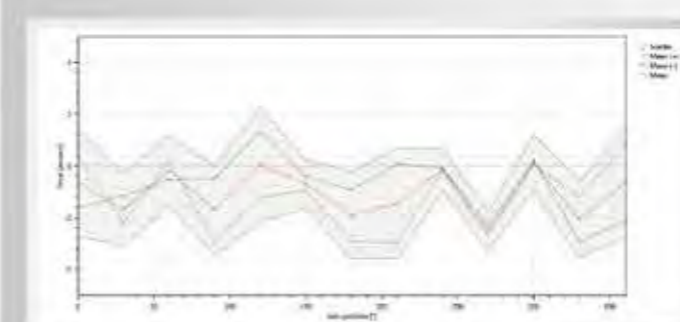

E.g. 5th Axis Laser Compensation under 10 arcsecs.

Angular C - Analysis features VDI 3441	
Name	Value (arcsecs)
Maximum reversal (U max)	3.1
Maximum scatter (Ps max)	2.1
Positional uncertainty (P)	<b>5.9</b>
Positional deviation (Pa)	2.7
Mean reversal	1.5
Mean scatter (Ps mean)	1.5

(Without scales)

**Factory Conditions**



# MEGA 30V



# MEGA 40V



## MACHINE DIMENSIONS

Unit: mm

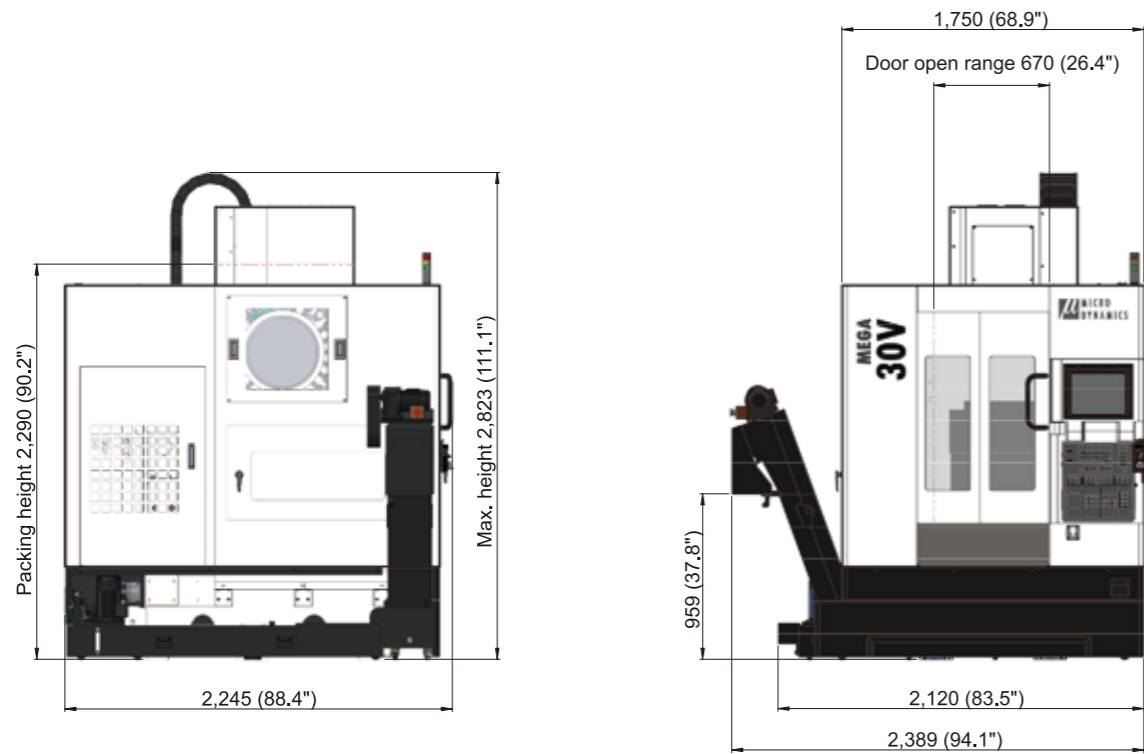

## MACHINE DIMENSIONS

Unit: mm

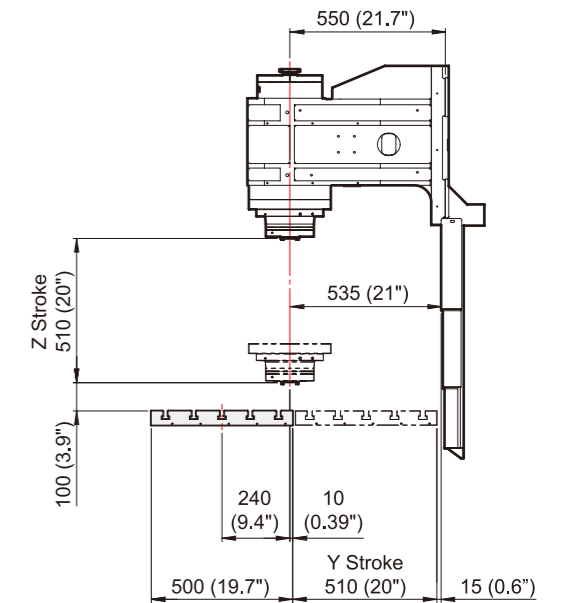
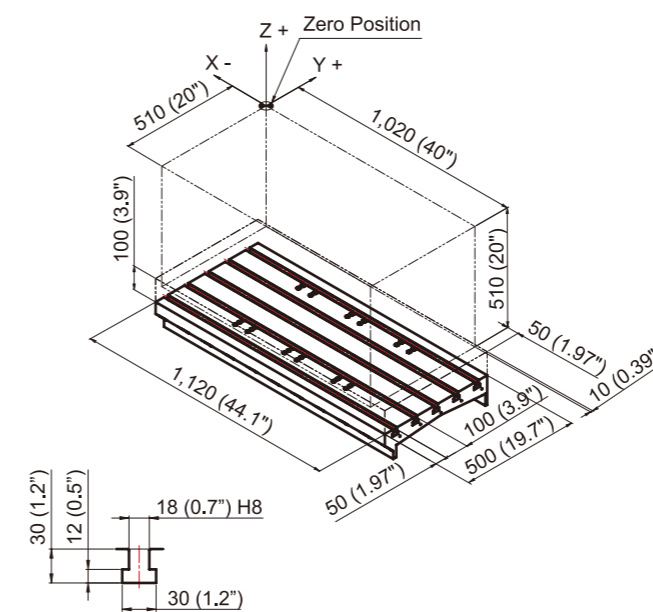
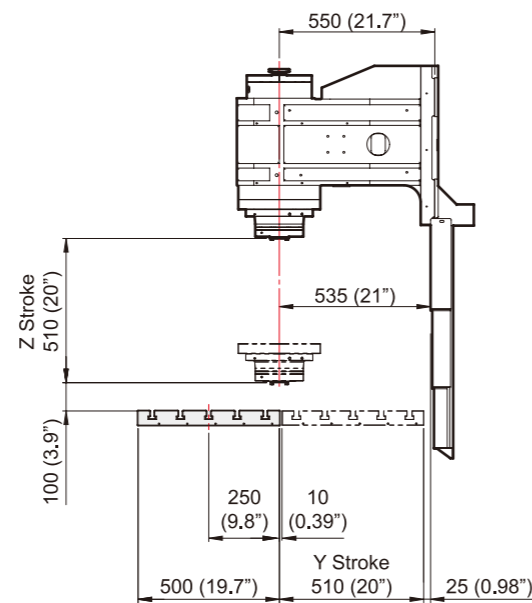
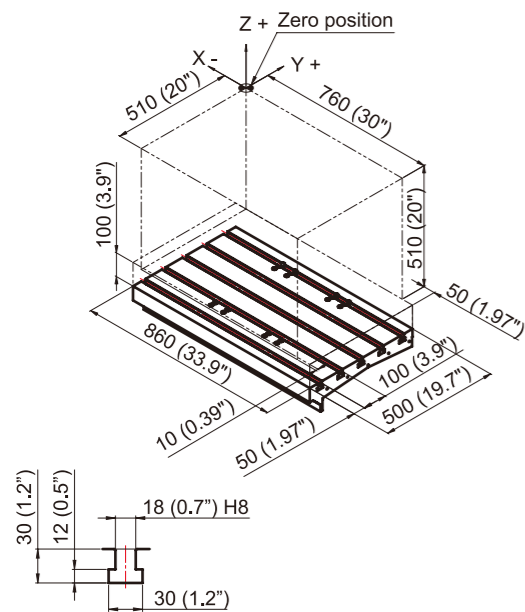
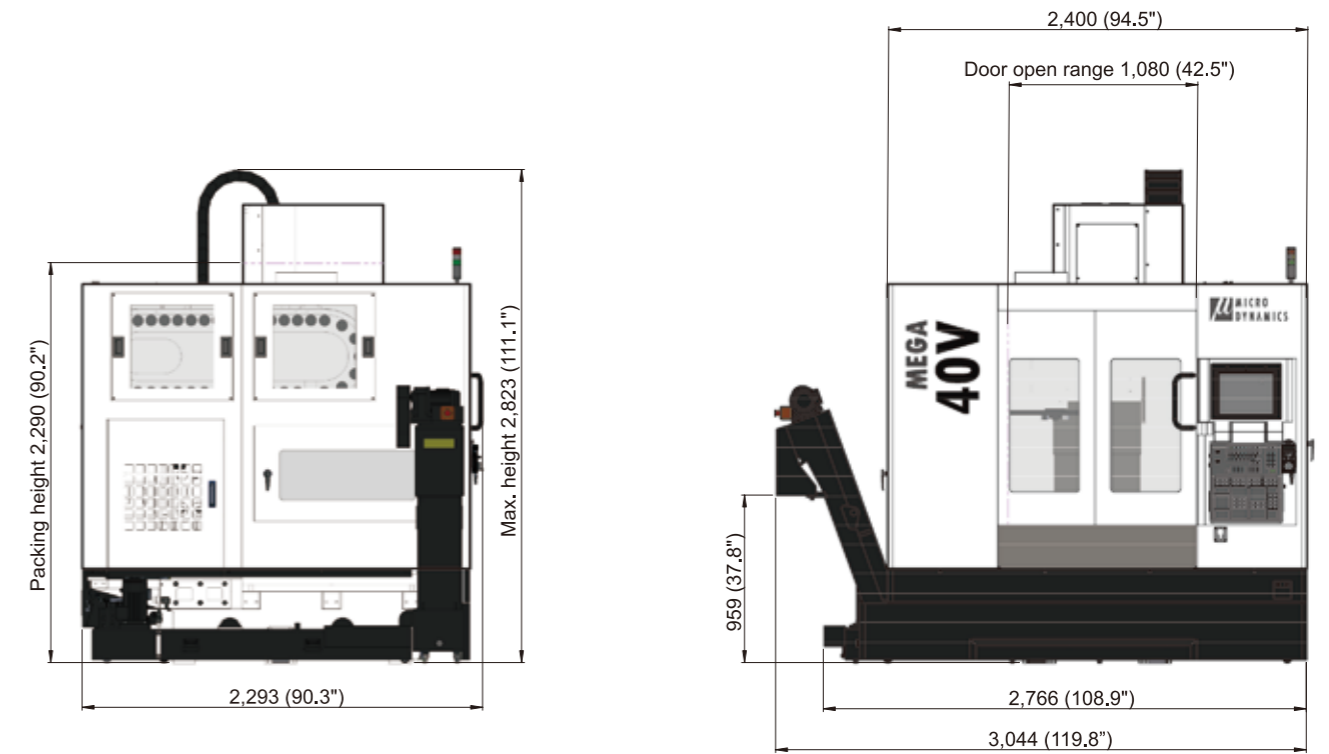

# MEGA 20VAPC



# MEGA 30VT



## MACHINE DIMENSIONS

Unit: mm

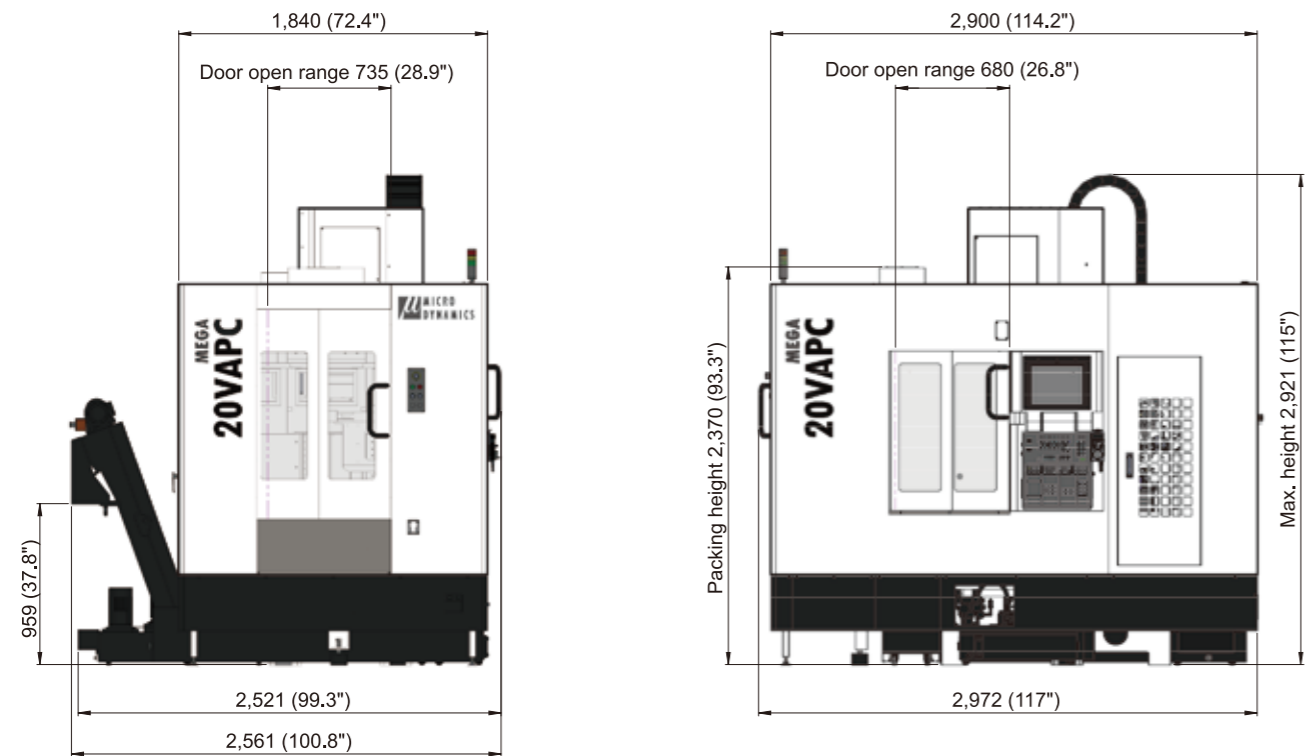

## MACHINE DIMENSIONS

Unit: mm

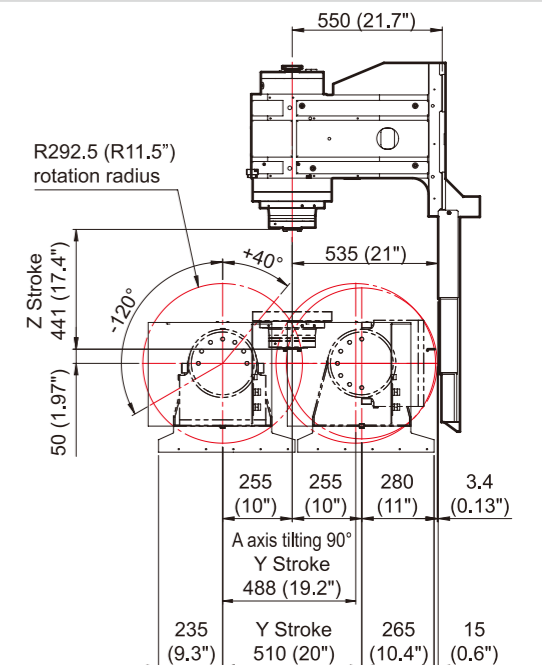
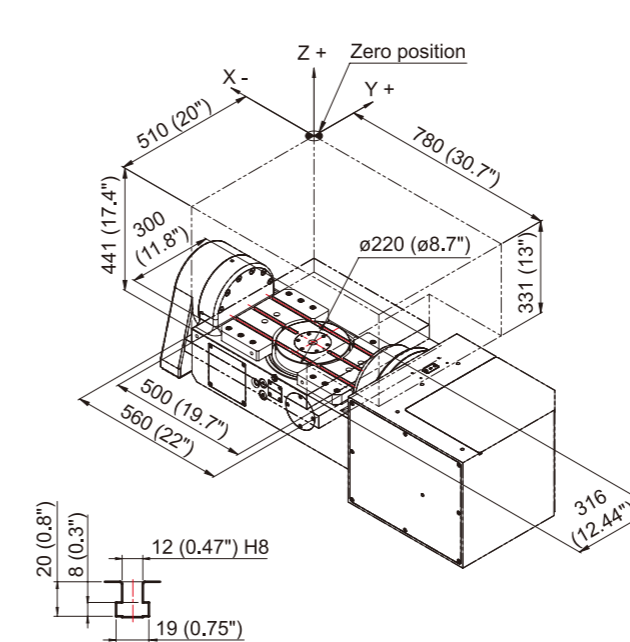
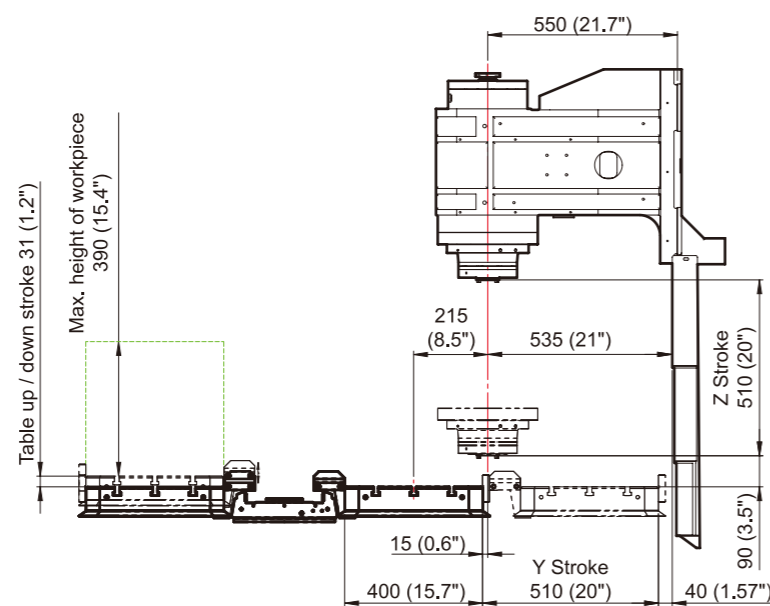
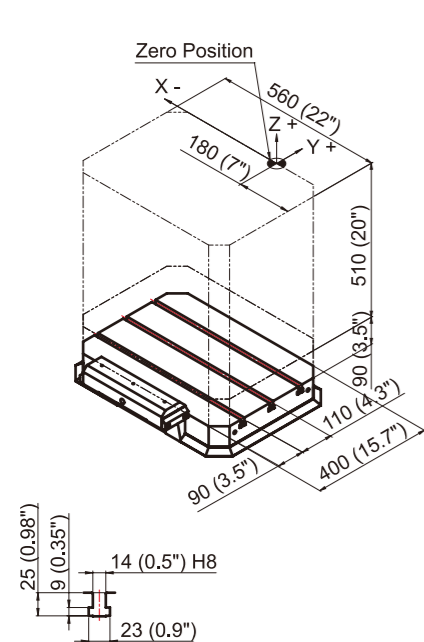
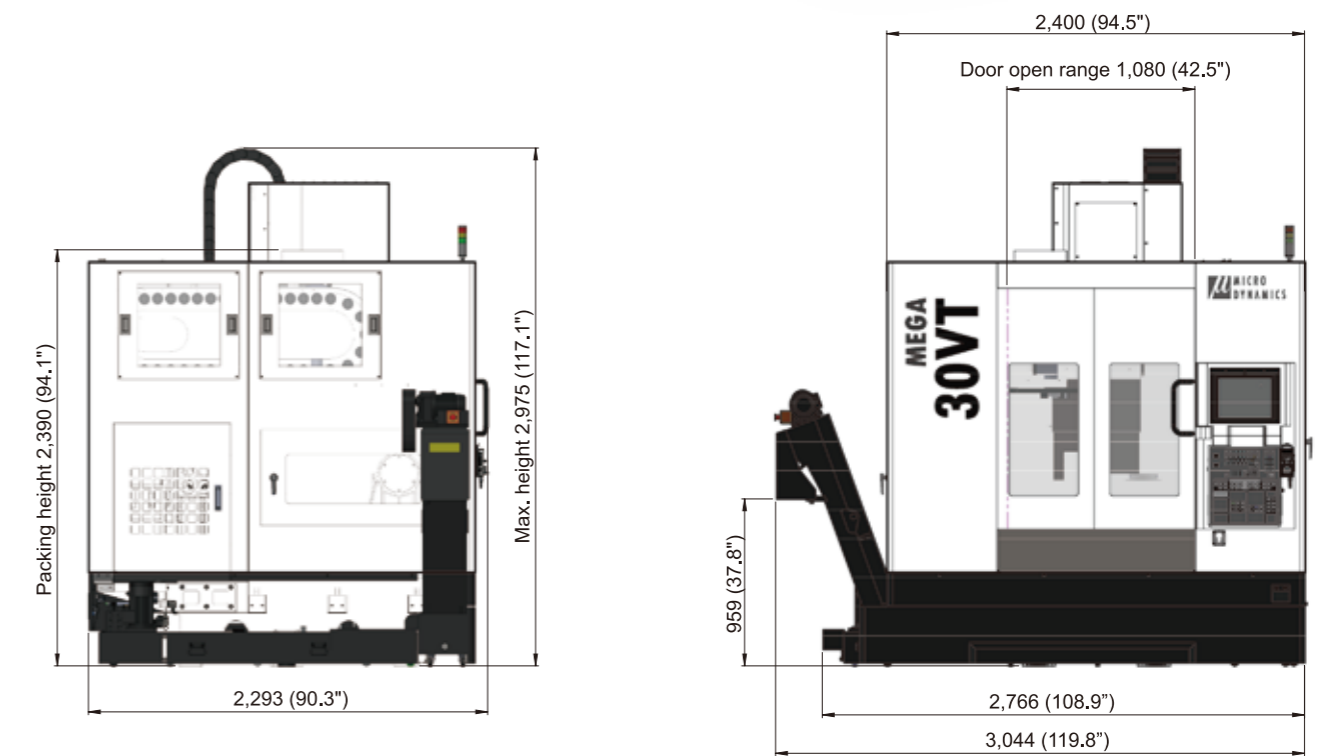

# TERA 40V



# TERA 50V



## MACHINE DIMENSIONS

Unit: mm

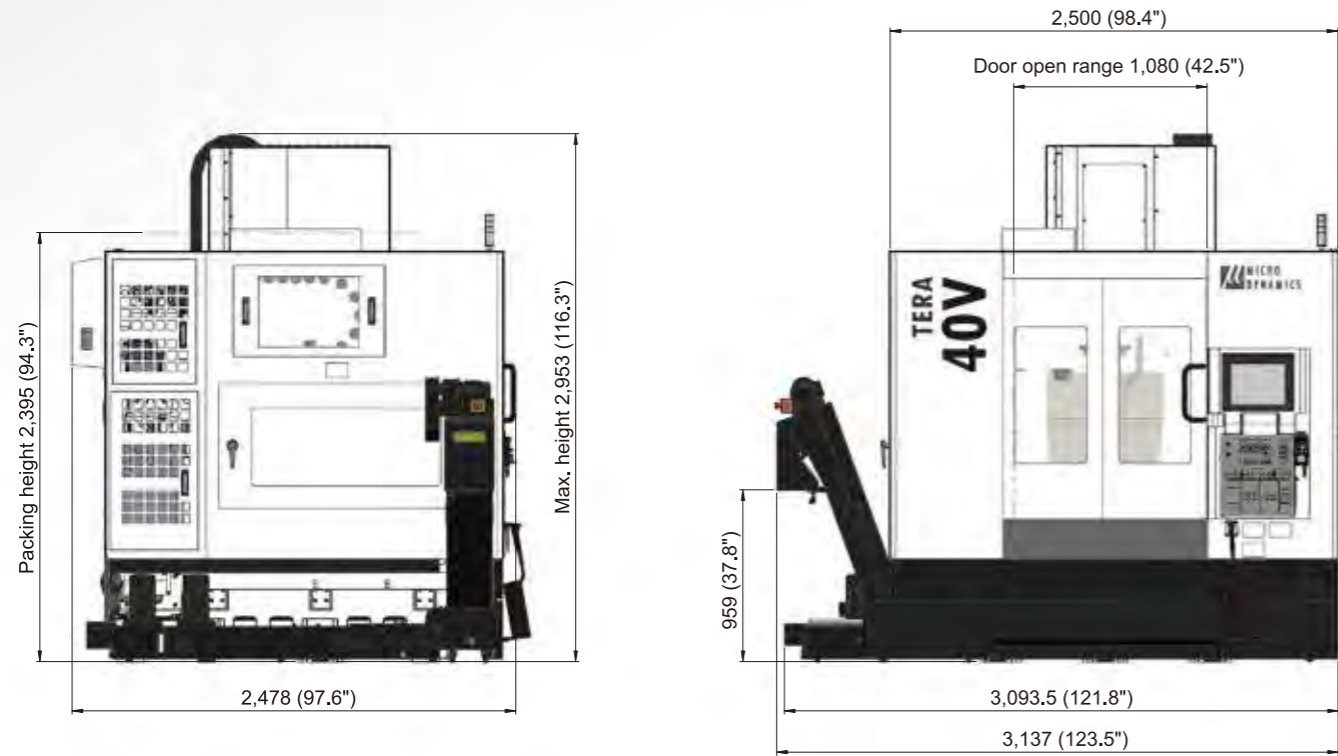

## MACHINE DIMENSIONS

Unit: mm

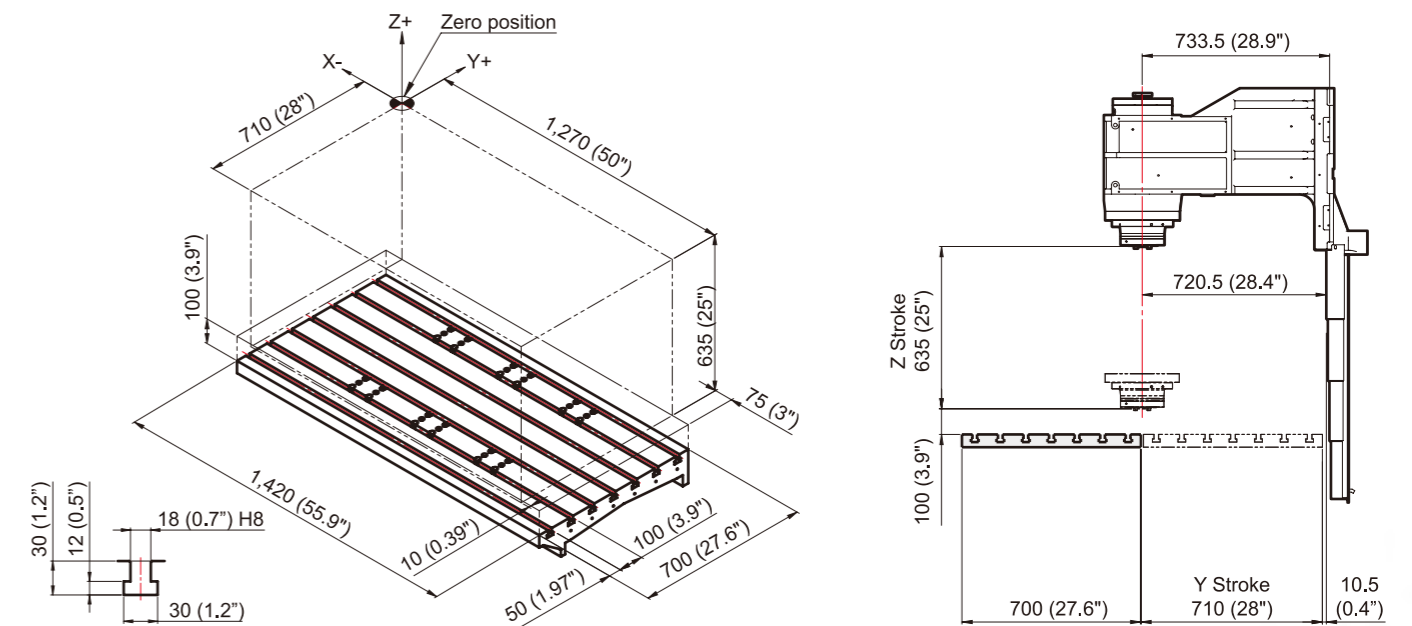
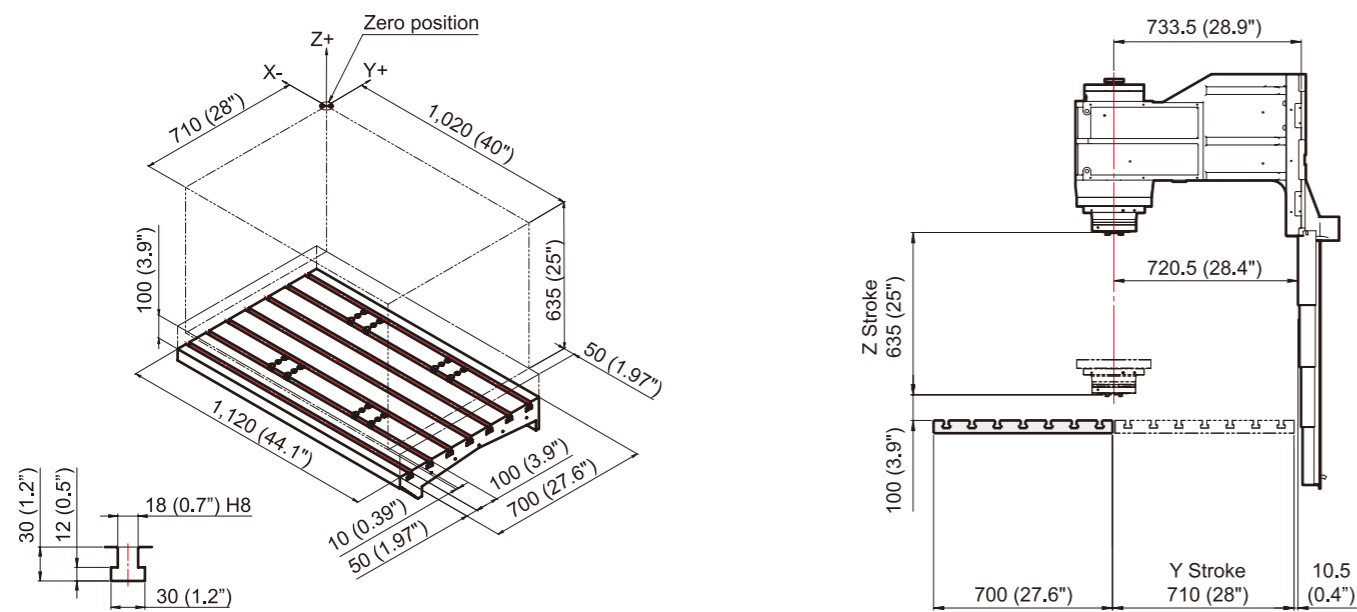
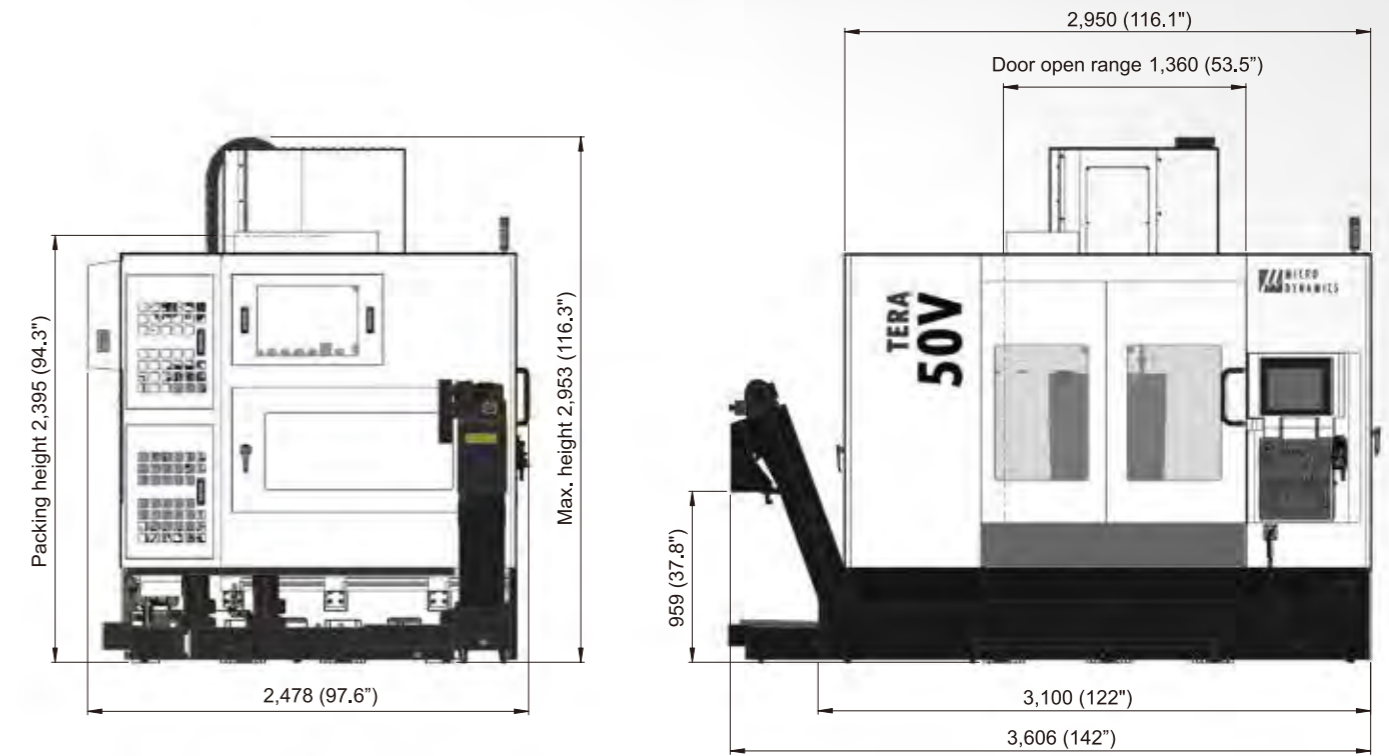



# EQUIPMENT

● Standard ○ Optional

SERIES / MODELS	MEGA				TERA				
	30V	40V	20VAPC	30VT	40V	50V	60V	50VT	
<b>Spindle</b>	15,000 rpm Built-in Spindle	●	●	●	●	●	●	●	
	18,000 rpm Built-in Spindle	○	○	○	○	○	○	○	
	20,000 rpm Built-in Spindle	○	○	○	○	○	○	○	
<b>Accuracy &amp; Scales</b>	DYPEC® Thermal Compensation	●	●	●	●	●	●	●	
	X/Y/Z Axis Linear Scale	○	○	○	○	○	○	○	
	A/C Axis Rotary Scale	-	-	-	○	-	-	○	
<b>Control &amp; HMI</b>	15" Touchscreen Display	●	●	●	●	●	●	●	
	Micro Dynamics® HMI	●	●	●	●	●	●	●	
	Tool Measurement / Workpiece Measurement	○	○	○	○	○	○	○	
	8 M-Codes (M20 ~ M27)	●	●	●	●	●	●	●	
	Additional 8 M-Codes (M130 ~ M137)	○	○	○	○	○	○	○	
<b>Tool Magazine</b>	Automatic Power Off	●	●	●	●	●	●	●	
	Tool Magazine Capacity - 30 (*)	●	-	-	-	-	-	-	
	Tool Magazine Capacity - 40 (*)	-	●	●	●	●	●	●	
	Servo Tool Magazine (**)	○	○	○	○	○	○	○	
	ATC Auto Door (**)	○	○	○	○	○	○	○	
	ATC Magazine Panel	-	●	●	●	●	●	●	
<b>4th / 5th Axis</b>	Tool Magazine LED	●	●	●	●	●	●	●	
	4th Axis Pre-wiring	○	○	○	○	○	○	○	
	Metal Coolant Ring	○	○	○	○	○	○	○	
	Spinning Window	○	○	○	○	○	○	○	
	20-Bar (290 psi) / 40-Bar (580 psi) / 70-Bar (1,000 psi) CTS	○	○	○	○	○	○	○	
	CTS Preparation (without Rotary Union)	●	●	●	●	●	●	●	
	Coolant Gun & Air Gun	●	●	●	●	●	●	●	
	Scrapers Type Chip Conveyor	●	●	●	●	●	●	●	
	Chain Type Chip Conveyor	○	○	○	○	○	○	○	
	Drum Type Chip Conveyor	○	○	○	○	○	○	○	
<b>Coolant &amp; Chip Management</b>	Rear Type Chip Conveyor (*)	○	○	○	○	○	○	○	
	Twin Chip Augers	●	●	●	●	●	●	●	
	Disc Type Oil Skimmer	○	○	○	○	○	○	○	
	Oil Mist Collector	○	○	○	○	○	○	○	
	MEGA series 100 / 150 / 250 mm (**)	○	○	○	○	-	-	-	
	TERA series 120 mm (***)	-	-	-	-	○	○	○	
<b>Face Plate</b>	300 / 350 mm Diameter Face Table	-	-	-	○	-	-	-	
	500 / 630 mm Diameter Face Table	-	-	-	-	-	-	○	
<b>Safety &amp; Power</b>	CE-Conformity Package	○	○	○	○	○	○	○	
	Transformer	○	○	○	○	○	○	○	
<b>Automation</b>	Automatic Door (Pneumatic / Servo)	○	○	○	○	○	○	○	
	Full Chip Enclosure	●	●	●	●	●	●	●	
<b>Others</b>	Safety Door	●	●	●	●	●	●	●	
	Manuals / Tool Kit / Foundation Kit	●	●	●	●	●	●	●	

(\*) Factory order (\*\*) MEGA 20VAPC standard is 100 mm, MEGA 30VT standard is 150 mm. (\*\*\*) TERA 50VT standard is 120 mm.

## TOOL SYSTEM

### BT 40

#### Tool Shank JIS6339

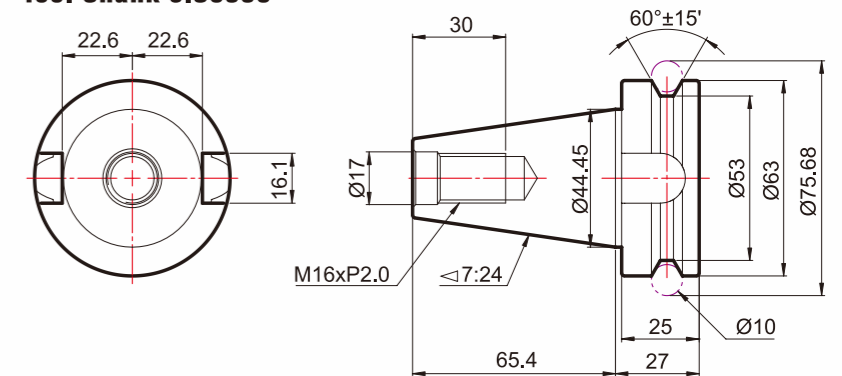

#### Pull Stud JIS6339

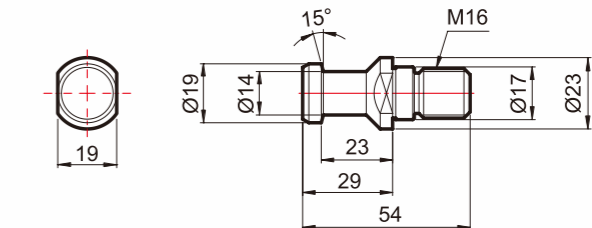

Unit: mm

### DIN 40

#### Tool Shank DIN69871

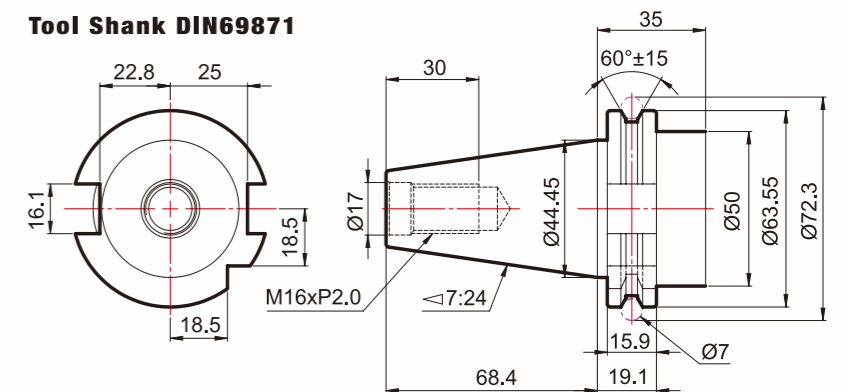

#### Pull Stud DIN69872

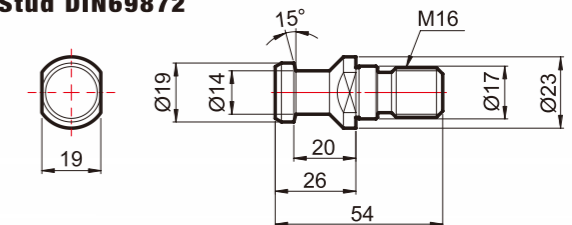

Unit: mm

# SPECIFICATIONS

ITEM	UNIT	MEGA 30V	MEGA 40V	MEGA 20VAPC	MEGA 30VT	TERA 40V	TERA 50V	TERA 60V	TERA 50VT		
<b>TRAVEL</b>	X Axis	mm	760	1,020	600	780	1,020	1,270	1,524	970	
	Y Axis	mm	510	510	510	510	710	710	710	710 / 650 (90°)	
	Z Axis	mm	510	510	510	441	635	635	635	500	
	A Axis (Tilting Axis)	deg	N/A			40° ~ -120°		N/A		40° ~ -120°	
	C Axis (Rotary Axis)	deg	N/A			360°		N/A		360°	
	Spindle Nose to Table Surface	mm	100 ~ 610	100 ~ 610	90 ~ 600	50 ~ 491	100 ~ 735	100 ~ 735	100 ~ 735	50 ~ 550	
	Spindle Center to Column Front	mm	550	550	550	550	733.5	733.5	733.5	733.5	
<b>TABLE</b>	Table Size	mm	860 × 500	1,120 × 500	560 × 400	ø220 (500 × 300)	1,120 × 700	1,420 × 700	1,724 × 700	ø320 (720 × 400)	
	Min. Table Index Unit	deg	N/A			0.001°		N/A		0.001°	
	Max. Table Load	kg	800	1,000	200 × 2	150 (0°~45°) / 85 (45°~90°)	1,500	1,500	2,000	250 (0°~45°) / 150 (45°~90°)	
	Table Height (from the Ground)	mm	840	840	950	1,108	900	900	900	1,205	
<b>SPINDLE</b>	Spindle Taper		40 Taper Dual Contact								
	I.D. of Spindle Bearing	mm	ø70								
	Spindle Speed	rpm	50 ~ 15,000 (optional 18,000 & 20,000)								
	Max. Power	kW	31								
	Max. Cutting Torque	Nm	141								
	Max. Speed for Rigid Tapping	rpm	6,000								
<b>FEEDRATE</b>	Rapid Feedrate - X Axis	m/min	52	52	52	48	52	52	52	48	
	Rapid Feedrate - Y Axis	m/min	52	52	52	48	52	52	52	48	
	Rapid Feedrate - Z Axis	m/min	48	48	48	48	48	48	48	48	
	Rapid Feedrate - A (Tilting) Axis	rpm	N/A			25		N/A		33	
	Rapid Feedrate - C (Rotary) Axis	rpm	N/A			33		N/A		66	
	Cutting Feedrate	m/min	0 ~ 20								
<b>ATC</b>	Magazine Capacity		30							40	
	Tool Selection		Bi-Direction / Random								
	Tool Shank Type		JIS6339 (BT40) / DIN69871 (DIN40)								
	Pull Stud Type		JIS6339 / DIN69872								
	Max. Tool Diameter x Length	mm	ø75 × 230	ø75 × 300	ø75 × 240	ø75 × 300	ø75 × 260	ø75 × 300			
	Without Adjacent Tool	mm	ø150								
	Max. Tool Weight	kg	7								
<b>PERIPHERAL</b>	Power Consumption (220V/3PH)	KVA	30				40				
	Pneumatic Supply	L/min (ANR)	300 (0.6MPa)								
	Cutting Coolant Pump Motor	kW	1.1								
	Base Wash Pump Motor	kW	1.1								
	CTS Pump Motor (Opt.)	kW	3								
	Coolant Tank Capacity	L	250	300	300	300	300	400	400	400	
	Foot Print Size (W x D)	mm	2,389 × 2,245	3,044 × 2,293	2,561 × 2,972	3,044 × 2,293	3,137 × 2,478	3,606 × 2,478	4,322 × 2,478	3,656 × 2,478	
	Machine Height (H)	mm	2,823	2,823	2,921	2,975	2,953	2,953	2,953	3,005	
	Packing Size (W x D x H)	mm	2,750 × 2,300 × 2,550	3,300 × 2,310 × 2,550	3,200 × 2,200 × 2,550	3,300 × 2,310 × 2,550	3,400 × 2,310 × 2,550	4,100 × 2,310 × 2,550	4,900 × 2,310 × 2,550	3,400 × 2,300 × 2,550	
	Machine Net Weight	kg	4,890	5,610	6,400	6,350	8,040	8,600	9,170	9,560	
	Machine Gross Weight	kg	5,070	5,850	6,710	6,590	8,280	8,890	9,560	9,910	
	Positioning Accuracy / Full Stroke	mm	0.005 (VDI 3441)								
	Repeatability Accuracy	mm	0.0025								

Note: Specifications subject to change without notice.