

CNC Cylindrical Grinder

EGP, EGA & EPA-A series

EGP, EGA & EPA-A CNC · Printed in Taiwan · E3 · 12/2019 · en

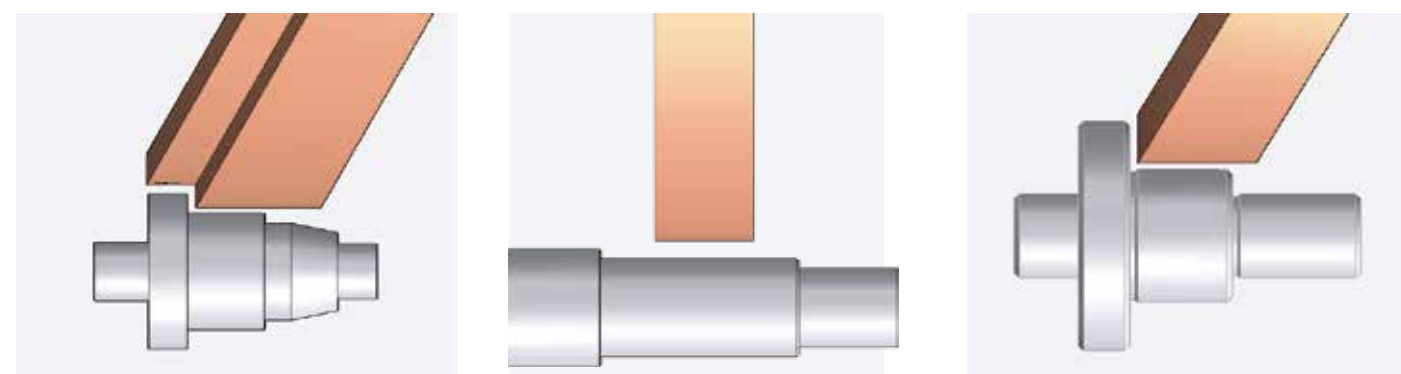

Grinder Professionals

e-tech USA

6435 Alondra Blvd, Paramount,
CA.90723

E-mail : info@supertecusa.com

TEL : (562) 220-1675

e-tech Asian Operation Center

No.36, Ln.686, Sec.4, Changping Rd.,

Daya Dist., Taichung City 428

Taiwan (R.O.C)

E-mail : info@etechtw.com

TEL : 886-425686418

www.etechtw.com



E-tech Machinery Grinder Professional



FACEBOOK



YOUTUBE



WEBSITE

Features	1
Features	3
High Precision Grinding Technology	5
Grinding Application	7
In-Process Inspections	9
Specification: EGP Series	11
Specification: EGA Series	13
Specification: EGP-A Series	15

1 EGP, EGA & EGP-A Series High Precision CNC cylindrical Grinder

EGP, EGA & EGP-A Series grinders are designed for high precision, high efficiency, and ease of operation. They are suitable for various applications including but not limited automotive, aerospace, medical instrument, tooling, job shop, and mold industries.

Features

- e-tech Machinery Inc. introduces EGP, EGA & EGP-A series CNC cylindrical grinders with superb grinding capabilities and choice of control options. The customers' requirements can be met with a choice of many machine options such as a touch probe, automatic sizing device, or swing down ID grinding attachment. The complete product line offers a wide range of between center distances and center heights in both plunge and angular wheelhead designs. Automation and turnkey solutions can be offered optional equipment.

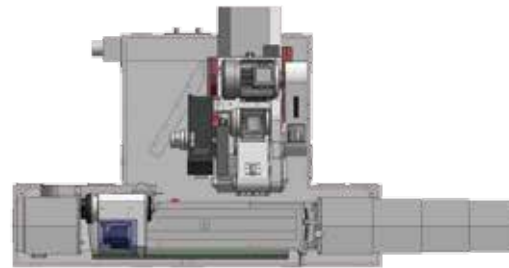

EGP - Plunge Wheelhead
Max. Grinding OD: 230-480 mm
Distance between Centers: 500-3000 mm

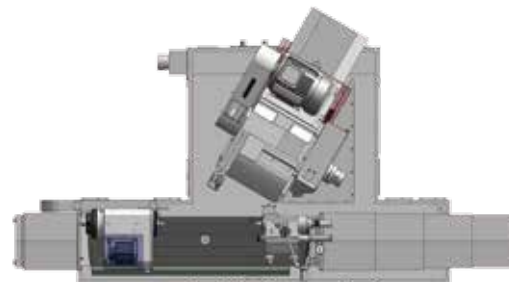

EGA - Angular Wheelhead
Max. Grinding OD: 230-480 mm
Distance between Centers: 500-2000 mm

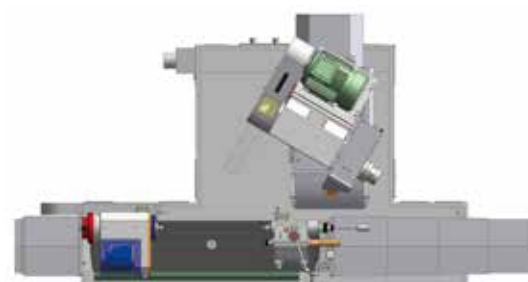

EGP-A - Angular Wheelhead Plunge type
Max. Grinding OD: 330-480 mm
Distance between Centers: 600-2000 mm

CNC Controller

- A selection of CNC control systems including Fanuc, Mitsubishi, Siemens, PC-BASE are available.
- For small and medium size workpiece grinding operations, e-tech incorporates the iGrind graphic conversational programming software.



FANUC Controller



Mitsubishi Controller

iGrind

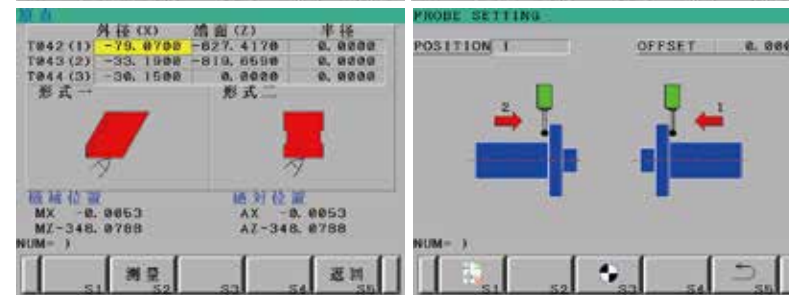

- OD Grinding / End Face Grinding / Form Grinding
- Form Dressing w/ Auto Compensation
- Multiple Section Grinding Sequences
- Setup Parameter Storage
- Graphic Parameter Instruction

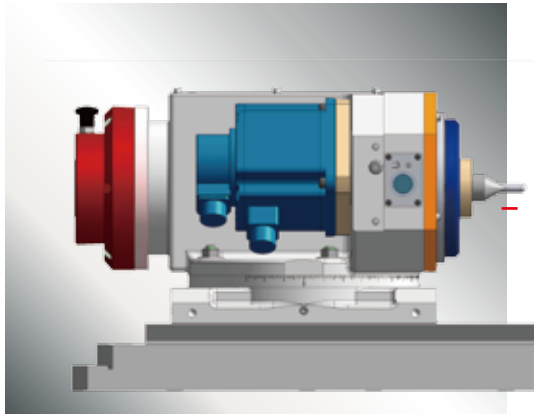

Work Head

NN bearing designed work spindle offers heavy duty load capacity, optimal rotation accuracy, and high rigidity. The servo motor drive offers steady speed and torque during the grinding operation. A positive air purge system keeps grinding swarf and coolant out of the work head, thus it prolongs its life.

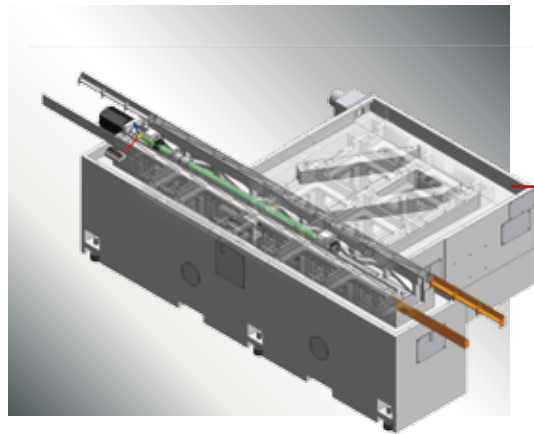

Rigid Machine Base

The machine based is designed to ensure the table is fully supported on both ends. The heavily ribbed box-type base is made of Meehanite casting, providing excellent rigidity and stability of the machine.

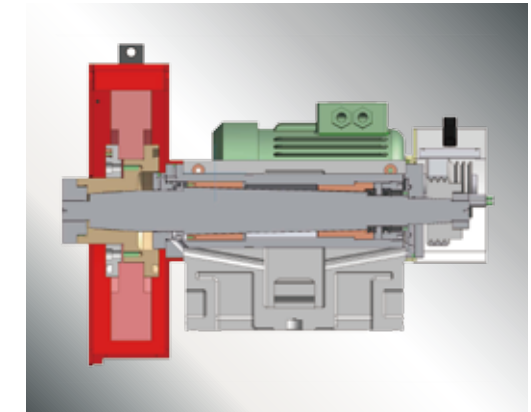
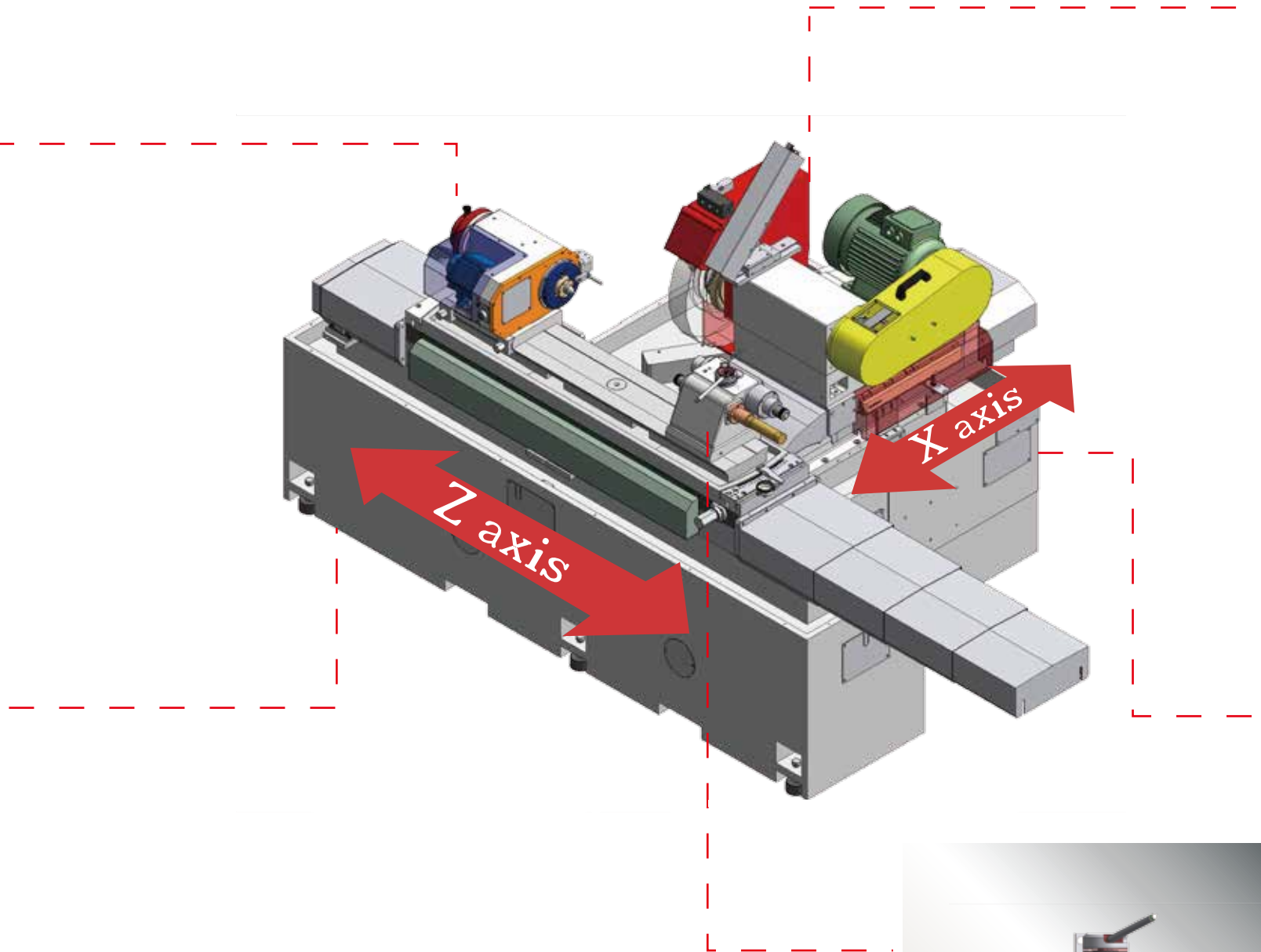

Wheel head Spindle Bearing Options:

- Standard — Contact Bearing Type Spindle is easy to maintain, environmentally friendly and minimizes thermal growth issues.
- Optional — Hydrodynamic Babbit Bearing Type Spindle applies SNM220 super alloy steel with multiple heat treatments makes the surface hardness of spindle up to HRC 62. These features ensure maximum cutting capability and best part finish performance in the grinding operation.

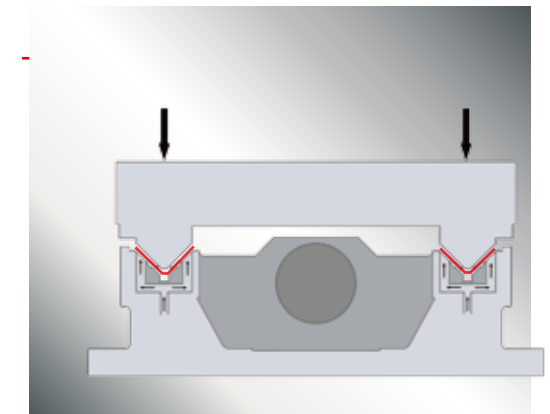

X-axis Guideway

The hand scraped Double V guideways provide maximum support to the wheel head for greater stability and grinding capacity. This design insures superior accuracy over the life of the machine.

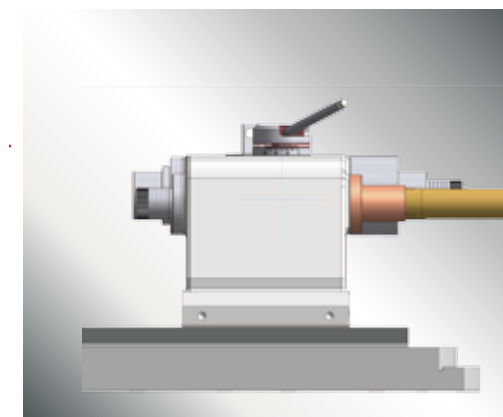

Tail Stock

A coolant nozzle is installed on the top of the tailstock for cooling the center tip. An air floating devise allows for smoother movement and protection of the table.

- An optional tailstock quill travel of 75mm helps to load/unload the workpiece with ease. The quill is oil-bathed to ensure smooth movement.
- An optional tailstock taper adjustment feature allows the operator to easily adjust for taper error.



- E-tech
- Other

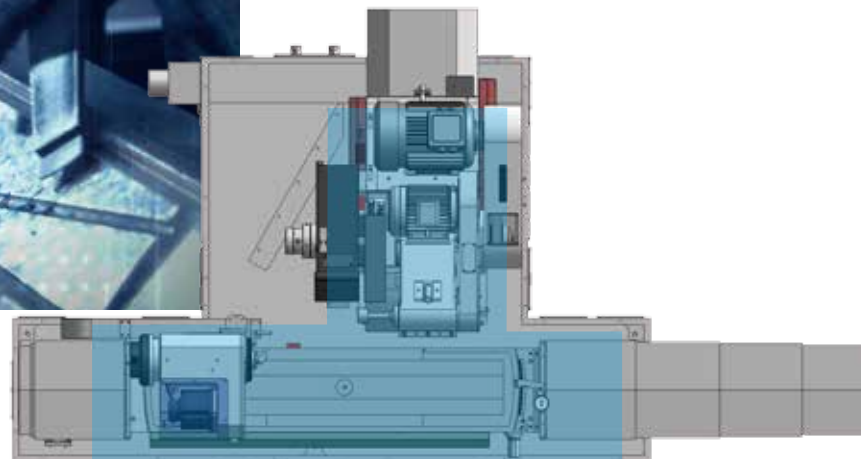

Plunge Grinding Example :

Model EGP-3260CNC

Grinding Conditions :

Wheel : WA60K(Φ405mm)

Workpiece

Name: Standard Grinding Test Workpiece

Material: SCM435

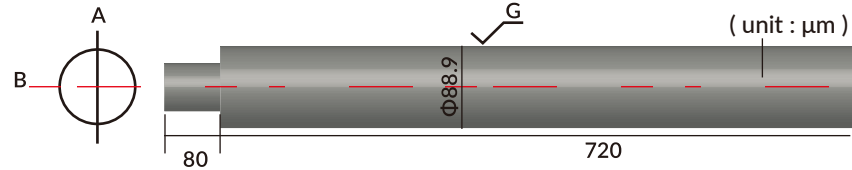

(unit : μm)	1	2	3	4	5	6	7	8	9
A	0.0	0.0	0.0	+1.0	+1.0	+1.0	0.0	0.0	0.0
B	0.0	0.0	0.0	+1.0	+1.0	+1.0	0.0	0.0	0.0

Cylindricity

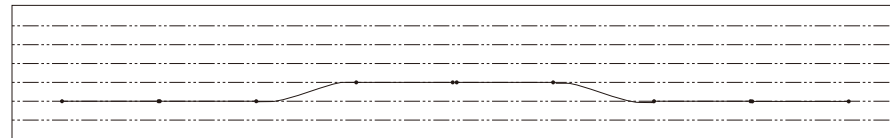

Traverse Grinding Example :

Model EGP-3260CNC

Grinding Conditions :

Wheel : WA60K(Φ405mm)

Workpiece

Name: Standard Grinding Test Workpiece

Material: SCM435

Roundness :
Part A 0.50 μm

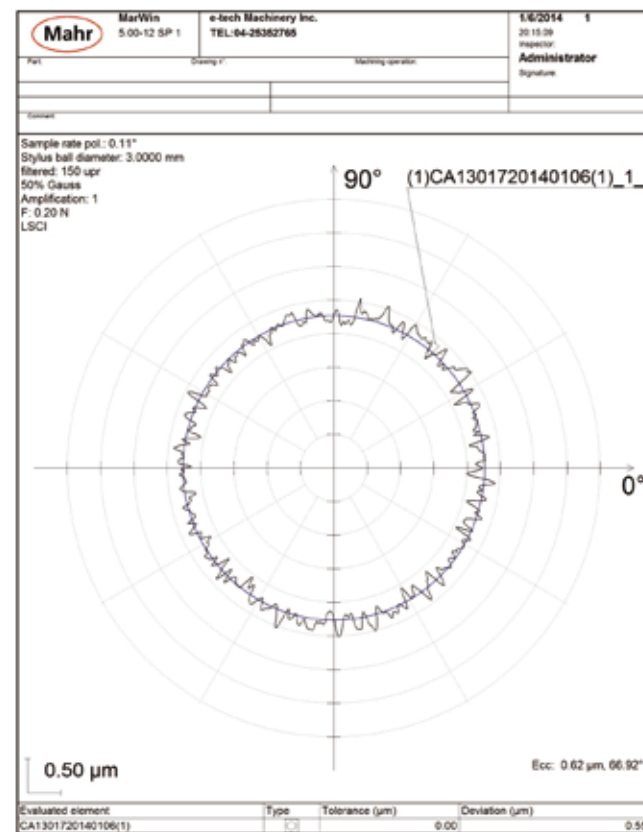
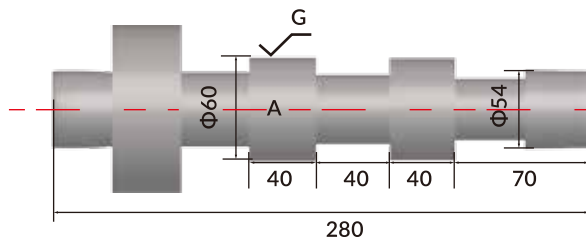

The grinding tests are grinding examples and do not represent actual grinding accuracies.

Wheel Dressing Cycle

Plunge Type

Straight - Parallel

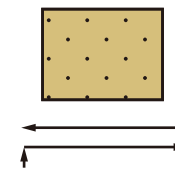

LHS Radius and Concave below

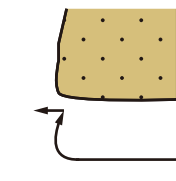

Steps Wheel (option)
(Under 15 points)

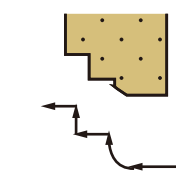

Angular Type

Wheel with radius

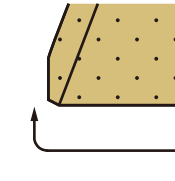

Steps Wheel (option)
(Under 15 points)

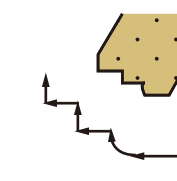

Remarks :

1. Max. 5 types of wheel profile can be saved.
2. Dressing condition can setup rough, intermediate and fine dressing
3. Machine with ID attachment, the dressing operation of ID wheel is manual operated.

Grinding Cycle

Plunge Type

1. Plunge grinding

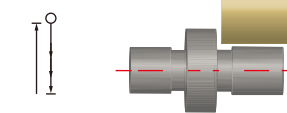

2. Traverse grinding

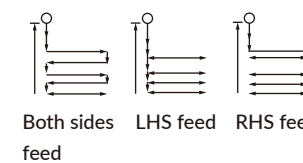

3. Plunge And Traverse grinding

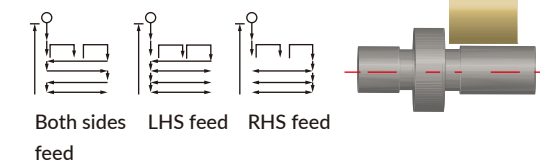

Angular Type

1. Plunge grinding

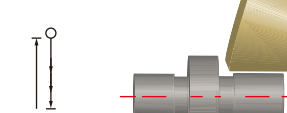

2. Traverse grinding

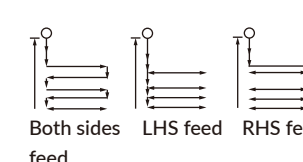

3. Plunge And Traverse grinding

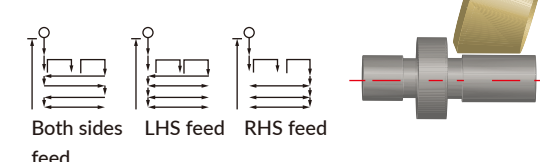

4. OD +End Face Grinding

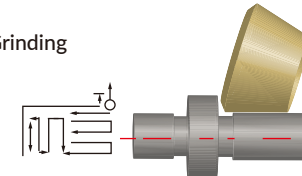

ID Grinding Cycle (using OD Grinding Cycle)

1. Plunge

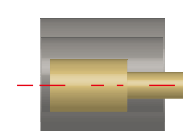

2. Traverse

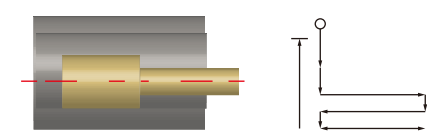

Remarks :

1. All cycles can be separated into rough grinding and fine grinding cycles.
2. Plunge type end face grinding can be implemented by manual operation and offsets.
3. ID grinding coordinate display is not the same to the dimension of the workpiece
4. Multiple steps ID grinding can be implemented by manual operation.

Spindle Shaft
Model: EGP-38200CNC

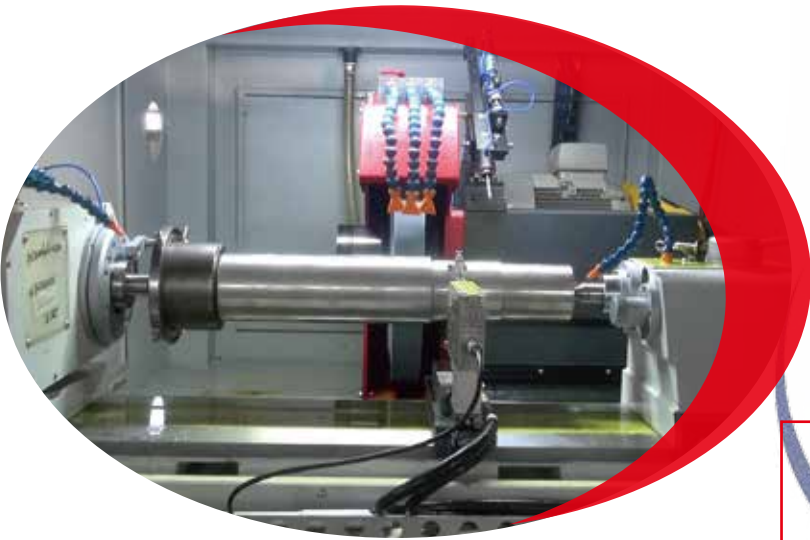

Rotor
Model: EGP-3260CNC



Printer Roller
Model: EGP-38200CNC



Crank Shaft
Model: EGA-3260CNC

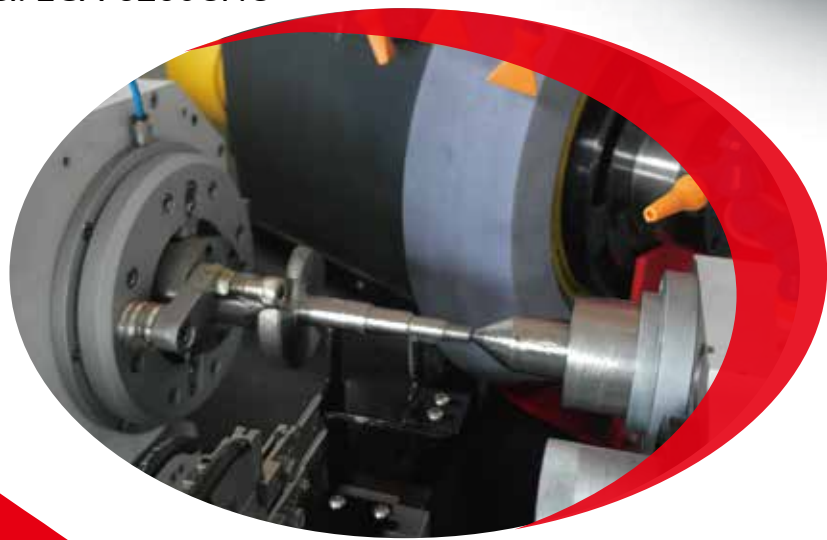

Gear Box Helical Gear
Model: EGP-3260CNC

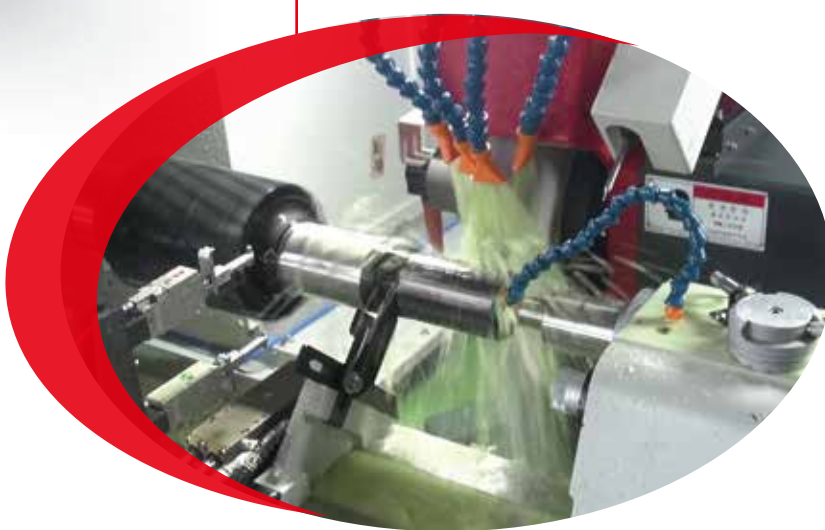

9 Accumulated inspection time of over 100 hours for each machine produced.

We know how it runs and we know how it is inspected

In-Process Inspections



(Wenzel CMM LH65)

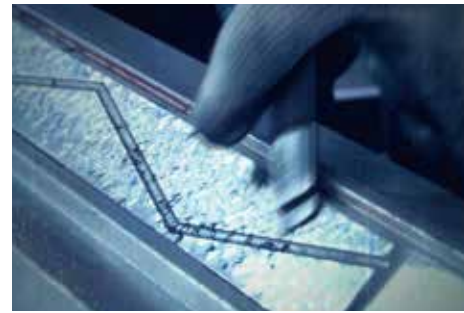
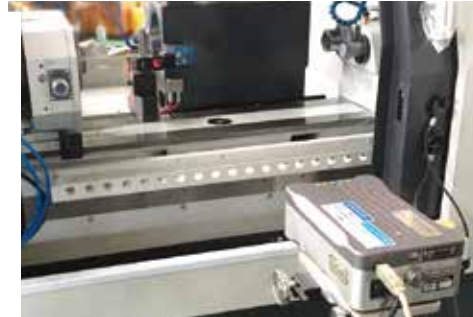

Workpiece Inspections



Mahr cylinder formtester: MMQ400
Mahr Surface Roughness Tester: PERTHOETER M2

Automation Solutions

Due to our extensive engineering knowledge and vast supplier network, we can provide the best grinding solutions.

1. In Process Gauging/Automation
2. Standard Automation Systems
3. Flexible Automation



> General purpose production

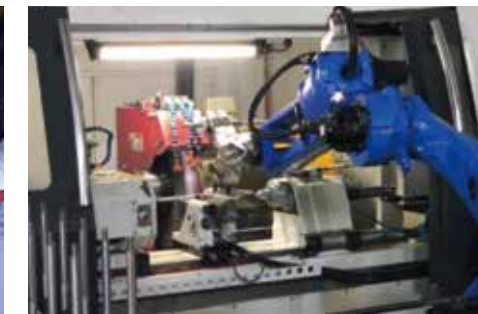

> Load / Unloading solutions
> Gantry Type and 6-axis Robot solution



> High Production Units
> Offers total solution for customized production process, grinders with the automation system, and turnkey operations.

MAHR MMQ400 Roundness Measurement

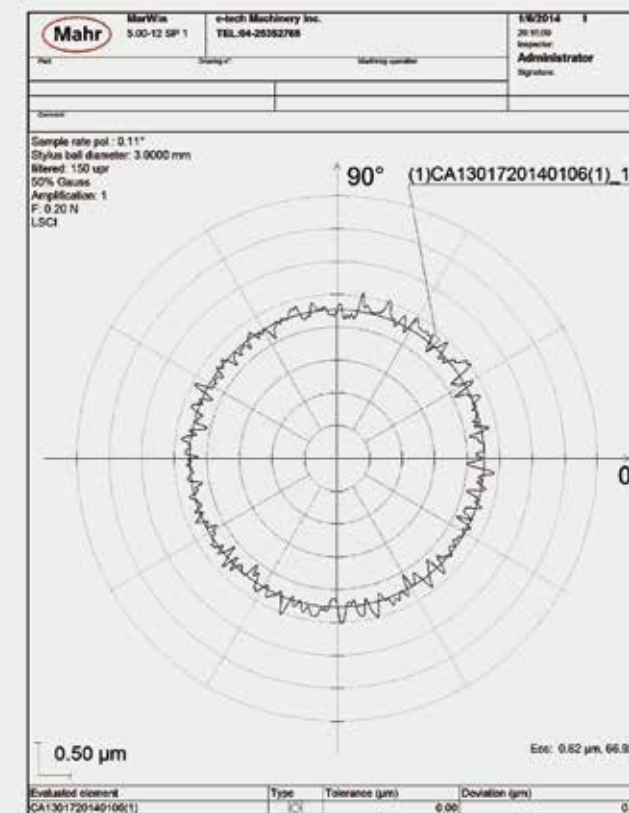

Model			EGP-2550	EGP-3260	EGP-32100	EGP-32150	EGP-32200	EGP-32250	EGP-32300	EGP-3860	EGP-38100
Grinding	Swing over table	mm	Ø250	Ø320	Ø320	Ø320	Ø320	Ø320	Ø320	Ø380	Ø380
Capacity	Distance between centers	mm	500	600	1000	1500	2000	2500	3000	600	1000
	Max. grinding diameter	mm	Ø230	Ø300	Ø300	Ø300	Ø300	Ø300	Ø300	Ø360	Ø360
	Max. load held between center	kg	80	150	150	150	250	250	250	150	150
	Center distance between spindle & slide table	mm	130	162	162	162	162	162	162	192	192
Grinding Wheel	Diameter x Width x Bore	mm	Ø455x50xØ127 (5") Opt.Ø455x50xØ152.4 (6")		Ø510x50-100xØ152.4(6") Opt.Ø610x50 - 100xØ203.2(8")			Ø510x50-100xØ152.4(6") Opt.Ø610x50 - 100xØ203.2(8")			
Motor	Motor rated power / max. torque	Kw/Nm	3.75kw / 13Nm		7.5kw/49Nm(Opt.11Kw/ 71Nm)			7.5kw/49Nm(Opt.11Kw/ 71Nm)			
	Wheel speed	rpm	1400		1250 (Opt.1650)			1250 (Opt.1650)			
Workhead	Swiveling angle	deg	90		90			90			
	Spindle speed (infinite variable)	rpm	10 ~ 600		10 ~ 600			10 ~ 600			
	Motor rated power / max. torque	kw	0.75		1.5			1.5			
	Center taper	-	MT3(Opt.MT4)		MT4 (Opt. MT5)			MT4 (Opt. MT5)			
	Spindle type	-	Fixed or Rotary		Fixed or Rotary			Fixed or Rotary			
	Diameter of bore	mm	Ø20		Ø26			Ø26			
Tailstock	Quill travel	mm	25		25 (Opt.50/75)			25 (Opt.50/75)			
	Center taper	-	MT3(Opt.MT4)		MT4 (Opt. MT5)			MT4 (Opt. MT5)			
X Axis	Travel	mm	200		280			280			
	Max. rapid feedrate	m/min	6		6			6			
	Heidenhain linear scale resolution	um	0.05		0.05			0.05			
	Min. increment	mm	0.0001		0.0001			0.0001			
	Servo motor rated power	kw	1.2(F)/1.5(M)		1.8(F)/2.2(M)			1.8(F)/2.2(M)			
Z Axis	Travel	mm	750	900	1300	1950	2450	2950	3450	900	1300
	Swiveling angle	deg	±7	±9	±7	±5	±5	±3	±2	±9	±7
	Max. rapid feedrate	m/min	8		10			10			
	Min. increment	mm	0.0001		0.0001			0.0001			
	Servo motor rated power	kw	1.2(F)/1.5(M)	1.8(F)/2.2(M)		2.5(F)/3.5(M)			1.8(F)/2.2(M)		
Motor	Hydraulic pump	kw	0.38		0.38			0.38			
	Hydrodynamic GW spindle lubrication pump	kw	0.2		0.2			0.2			
	Guide way lubrication pump	kw	0.2		0.2			0.2			
	Coolant pump	kw	0.2		0.2			0.2			
Machine	Net Weight (semi-enclosed splash guard)	kg	3100	5600	5900	6300	6700	7100	7500	5700	6000
	Gross Weight	kg	3800	6400	6700	7100	7500	7900	8300	6500	6800

Model			EGP-38150	EGP-38200	EGP-38250	EGP-38300	EGP-5060	EGP-50100	EGP-50150	EGP-50200	EGP-50250	EGP-50300
Grinding	Swing over table	mm	Ø380	Ø380	Ø380	Ø380	Ø500	Ø500	Ø500	Ø500	Ø500	Ø500
Capacity	Distance between centers	mm	1500	2000	2500	3000	600	1000	1500	2000	2500	3000
	Max. grinding diameter	mm	Ø360	Ø360	Ø360	Ø360	Ø480	Ø480	Ø480	Ø480	Ø480	Ø480
	Max. load held between center	kg	150	250	250	250	150	150	150	250	250	250
	Center distance between spindle & slide table	mm	192	192	192	192	255	255	255	255	255	255
Grinding Wheel	Diameter x Width x Bore	mm	Ø510x50-100xØ152.4(6") Opt.Ø610x50 - 100xØ203.2(8")				Ø510x50-100xØ152.4(6") Opt.Ø610x50 - 100xØ203.2(8")					
Motor	Motor rated power / max. torque	Kw/Nm	7.5kw/49Nm(Opt.11Kw/ 71Nm)				7.5kw/49Nm(Opt.11Kw/ 71Nm)					
	Wheel speed	rpm	1250 (Opt.1650)				1250 (Opt.1650)					
Workhead	Swiveling angle	deg	90				90					
	Spindle speed (infinite variable)	rpm	10 ~ 600				10 ~ 600					
	Motor rated power / max. torque	kw	1.5				1.5					
	Center taper	-	MT4 (Opt. MT5)				MT4 (Opt. MT5)					
	Spindle type	-	Fixed or Rotary				Fixed or Rotary					
	Diameter of bore	mm	Ø26				Ø26					
Tailstock	Quill travel	mm	25 (Opt.50/75)				25 (Opt.50/75)					
	Center taper	-	MT4 (Opt. MT5)				MT4 (Opt. MT5)					
X Axis	Travel	mm	280				280					
	Max. rapid feedrate	m/min	6				6					
	Heidenhain linear scale resolution	um	0.05				0.05					
	Min. increment	mm	0.0001				0.0001					
	Servo motor rated power	kw	1.8(F)/2.2(M)				1.8(F)/2.2(M)					
Z Axis	Travel	mm	1950	2450	2950	3450	900	1300	1950	2450	2950	3450
	Swiveling angle	deg	±5	±5	±3	±2	±9	±7	±5	±5	±3	±2
	Max. rapid feedrate	m/min	10				10					
	Min. increment	mm	0.0001				0.0001					
	Servo motor rated power	kw	2.5(F)/3.5(M)				1.8(F)/2.2(M)		2.5(F)/3.5(M)			
Motor	Hydraulic pump	kw	0.38				0.38					
	Hydrodynamic GW spindle lubrication pump	kw	0.2				0.2					
	Guide way lubrication pump	kw	0.2				0.2					
	Coolant pump	kw	0.2				0.2					
Machine	Net Weight (semi-enclosed splash guard)	kg	6400	6800	7200	7600	5800	6100	6500	6900	7300	7700
	Gross Weight	kg	7200	7600	8000	8400	6600	6900	7300	7700	8100	8500

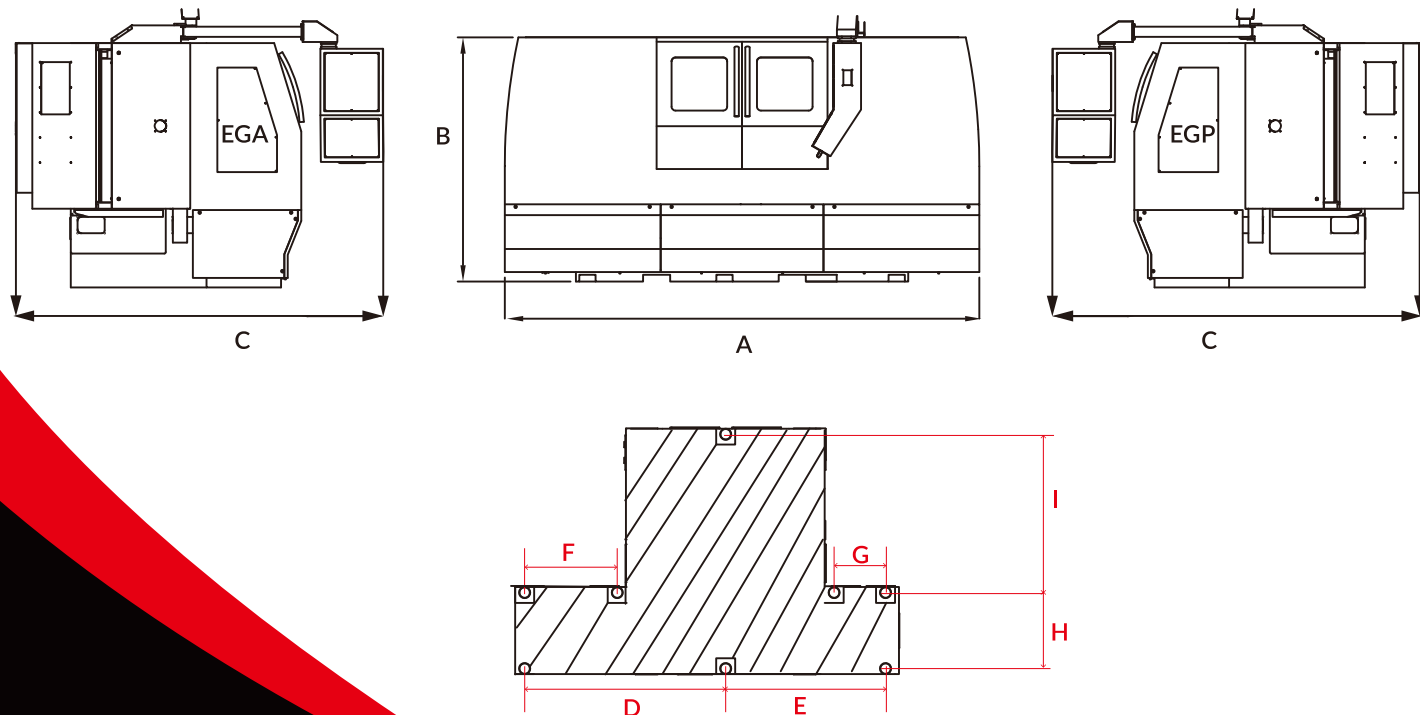

EGA	A	B	C	D	E	F	G	H	I	EGP	A	B	C	D	E	F	G	H	I
2550	3125	1810	2300	850	566	309	260	320	860	2550	3125	1810	2300	850	566	309	260	320	860
3260	3500	1800	2760	1270	1010	585	325	480	1000	3260	3500	1800	2760	1270	1010	585	325	480	1000
32100	4300	1800	2760	1670	1410	985	725	480	1000	32100	4300	1800	2760	1670	1410	985	725	480	1000
32150	5600	1800	2760	2270	2010	1585	1325	480	1000	32150	5600	1800	2760	2270	2010	1585	1325	480	1000
32200	7055	1800	2850	2890	2630	2205	1945	560	1000	32200	7055	1800	2850	2890	2630	2205	1945	560	1000
3860	3500	1800	2760	1270	1010	585	385	480	1000	32250	8560	1800	2850	3390	3150	2700	2445	560	1000
38100	4300	1800	2760	1670	1410	985	725	480	1000	32300	10060	1800	2850	3890	3630	3205	2945	560	1000
38150	5600	1800	2760	2270	2010	1325	1585	480	1000	3860	3500	1800	2760	1270	1010	585	385	480	1000
38200	7055	1800	2850	2890	2630	1945	2205	560	1000	38100	4300	1800	2760	1670	1410	985	725	480	1000
5060	3500	1800	2760	1270	1010	585	385	480	1000	38150	5600	1800	2760	2270	2010	1325	1585	480	1000
50100	4300	1800	2760	1670	1410	985	725	480	1000	38200	7055	1800	2850	2890	2630	1945	2205	560	1000
50150	5600	1800	2760	2270	2010	1325	1585	480	1000	38250	8560	1800	2850	3390	3150	2700	2445	560	1000
50200	7055	1800	2850	2890	2630	1945	2205	560	1000	38300	10060	1800	2850	3890	3630	3205	2945	560	1000
50250	8560	1800	2850	3390	3150	2700	2445	560	1000	5060	3500	1800	2760	1270	1010	585	385	480	1000
50300	10060	1800	2850	3890	3630	3205	2945	560	1000	50100	4300	1800	2760	1670	1410	985	725	480	1000
										50150	5600	1800	2760	2270	2010	1325	1585	480	1000
										50200	7055	1800	2850	2890	2630	1945	2205	560	1000
										50250	8560	1800	2850	3390	3150	2700	2445	560	1000
										50300	10060	1800	2850	3890	3630	3205	2945	560	1000

Model		EGA-2550	EGA-3260	EGA-32100	EGA-32150	EGA-32200	EGA-3860	EGA-38100	Model	EGA-38150	EGA-38200	EGA-5060	EGA-50100	EGA-50150	EGA-50200				
Grinding	Swing over table	mm	Ø250	Ø320	Ø320	Ø320	Ø320	Ø320	Grinding	Swing over table	mm	Ø380	Ø380	Ø500	Ø500	Ø500			
Capacity	Distance between centers	mm	500	600	1000	1500	2000	2000	Capacity	Distance between centers	mm	1500	2000	600	1000	1500	2000		
	Max. grinding diameter	mm	Ø230	Ø300	Ø300	Ø300	Ø300	Ø300		Max. grinding length - dresser on workhead side - dresser on tailstock side (Opt.)	mm	Ø360	Ø360	Ø480	Ø480	Ø480	Ø480		
	Max. grinding length - dresser on workhead side	mm	350	450	850	1350	1850	1850			Max. load held between center	mm	1350	1850	450	850	1350	1850	
	Max. load held between center	kg	500	600	1000	1500	2000	2000				Center distance between spindle and slide table	mm	1500	2000	600	1000	1500	2000
	Center distance between spindle and slide table	mm	80	150	150	150	250	250					mm	150	250	150	150	150	250
Grinding	Infeed angle	deg	60°	60	60	60	60	60	Grinding	Infeed angle	deg	60	60	60	60	60			
Wheel	Diameter x Width x Bore	mm	Ø510x50xØ127 (5")	Ø510x50-100xØ152.4 (6")			Ø510x50-100xØ152.4 (6")			Wheel	Diameter x Width x Bore	mm	Ø510x50-100xØ152.4 (6")			Ø510x50-100xØ152.4 (6")			
	Motor rated power / max. torque	Kw/Nm	3.75kw / 13Nm	7.5kw/49Nm(Opt.11Kw/ 71Nm)			7.5kw/49Nm(Opt.11Kw/ 71Nm)				Motor rated power / max. torque	Kw/Nm	7.5kw/49Nm(Opt.11Kw/ 71Nm)			7.5kw/49Nm(Opt.11Kw/ 71Nm)			
	Wheel speed	rpm	1400	1250 (Opt.1650)			1250 (Opt.1650)				Wheel speed	rpm	1250 (Opt.1650)			1250 (Opt.1650)			
	Workhead Swiveling angle	deg	90	90			90				Workhead Swiveling angle	deg	90			90			
Workhead	Spindle speed (infinite variable)	rpm	10~600	10~600			10~600			Workhead	Spindle speed (infinite variable)	rpm	10~600			10~600			
	Motor rated power / max. torque	kw	0.75	1.5			1.5				Motor rated power / max. torque	kw	1.5			1.5			
	Center taper	-	MT3	MT4 (Opt. MT5)			MT4 (Opt. MT5)				Center taper	-	MT4 (Opt. MT5)			MT4 (Opt. MT5)			
	Spindle type	-	Fixed or Rotary	Fixed or Rotary			Fixed or Rotary				Spindle type	-	Fixed or Rotary			Fixed or Rotary			
	Diameter of bore	mm	Ø20	Ø26			Ø26				Diameter of bore	mm	Ø26			Ø26			
	Tailstock Quill travel	mm	25	25 (Opt.50/75)			25 (Opt.50/75)				Tailstock Quill travel	mm	25 (Opt.50/75)			25 (Opt.50/75)			
X Axis	Travel	mm	200	280			280			X Axis	Travel	mm	280			280			
	Max. rapid feedrate	m/min	6	6			6				Max. rapid feedrate	m/min	6			6			
	Heidenhain linear scale resolution	um	0.05	0.05			0.05				Heidenhain linear scale resolution	um	0.05			0.05			
	Min. increment	mm	0.0001	0.0001			0.0001				Min. increment	mm	0.0001			0.0001			
	Servo motor rated power	kw	1.2(F)/1.5(M)	1.8(F)/2.2(M)			1.8(F)/2.2(M)				Servo motor rated power	kw	1.8(F)/2.2(M)			1.8(F)/2.2(M)			
Z Axis	Travel	mm	750	900	1300	1950	2450	2450	Z Axis	Travel	mm	1950	2450	900	1300	1950	2450		
	Swiveling angle	deg	±7	±9	±7	±5	±5	±5		Swiveling angle	deg	±5	±5	±9	±7	±5	±5		
	Max. rapid feedrate	m/min	8	10			10			Max. rapid feedrate	m/min	10			10				
	Min. increment	mm	0.0001	0.0001			0.0001			Min. increment	mm	0.0001			0.0001				
	Servo motor rated power	kw	1.2(F)/1.5(M)	1.8(F)/2.2(M) 2.5(F)/3.5(M)			1.8(F)/2.2(M)			Servo motor rated power	kw	2.5(F)/3.5(M)			1.8(F)/2.2(M) 2.5(F)/3.5(M)				
Motor	Hydraulic pump	kw	0.38	0.38			0.38			Motor	Hydraulic pump	kw	0.38			0.38			
	Hydrodynamic GW spindle lubrication pump	kw	0.2	0.2			0.2				Hydrodynamic GW spindle lubrication pump	kw	0.2			0.2			
	Guide way lubrication pump	kw	0.2	0.2			0.2				Guide way lubrication pump	kw	0.2			0.2			
	Coolant pump	kw	0.2	0.2			0.2				Coolant pump	kw	0.2			0.2			
Machine	Net Weight (semi-enclosed splash guard)	kg	3100	5600	5800	6300	6700	6700	Machine	Net Weight (semi-enclosed splash guard)	kg	6300	6700	5600	5800	6300	6700		
	Gross Weight	kg	3500	6420	7500	7800	8200	8200		Gross Weight	kg	7800	8200	6420	7500	7800	8200		

Standard Accessories

Optional Accessories

- Infinite variable workhead w/servo motor
- Diamond Dresser and Stand
- Automatic wheel speed change (15 steps)
- Carbide tip center
- X Axis Heidenhain linear scale (resolution 0.05 um)
- Levelling bolts and blocks
- Operation manual and part lists
- Fanuc CNC Controller (Oi TF)
- Grinding Wheel + Wheel Flange
- Standard oil cooler (cooling fan)

- Standard coolant tank 140L
- MPG handwheel 2 Axes control
- Touch probe (for EGA series only)
- LED working light
- Tools and Tool Box
- Electricity cabinet w/ heat exchanger
- Semi-enclosed splash guard
- Wheel Extractor
- 4-color indication signal light
- Electrical wiring diagram

- BS VM25 Integration system (OD gauging+ crash & gap control + dynamic balance system)
- BS VM15 Integration system (OD gauging+ crash & gap control)
- Hydraulic tailstock (w/ foot pedal)
- Z Axis Heidenhain linear scale (resolution 0.05 um)
- Manual grinding wheel balance system (vibrator)
- Grinding wheel dynamic balance system
- Wheel spindle lubrication oil cooler for hydrodynamic spindle
- Gap & crash control device
- Safety door lock
- Workhead spindle adjustment arbor
- Auto gauging device
- Coolant system with magnetic separator & paper filter
- Coolant system with magnetic separator
- Coolant system with paper filter
- Oil & mist collecting system
- Spare grinding wheel flange
- Full-Carbide center tip

- FANUC Oi-TF iGrind program
- Mitsubishi controller (M80) iGrind program
- Electrical cabinet air conditioner
- Interanl grinding attachment (for EGP series only)
- Workhead upgrade to MT5 (not suitable for 25 series)
- Tailstock upgrade to MT5 (not suitable for 25 series)
- Roller type balancing stand/ arbor
- Automatic 3-jaw hydraulic chuck
- CE standard electrical cabinet
- Touch probe
- Transformer
- Workpiece carrier
- Full-enclosed splash guard
- Workpiece supporting seat, 2pc / set
- 2 Point Steady Rest
- 3-point steady rest
- 3-jaw scroll chuck
- 4-jaw scroll chuck

* E-tech reserves the right to change specifications without notice

Model		EGP-3860A	EGP-38100A	EGP-38150A	EGP-38200A	EGP-5060A	EGP-50100A	EGP-50150A	EGP-50200A	
Grinding	Swing over table	mm	Ø380	Ø380	Ø380	Ø380	Ø500	Ø500	Ø500	Ø500
Capacity	Distance between centers	mm	600	1000	1500	2000	600	1000	1500	2000
	Max. grinding diameter	mm	Ø360	Ø360	Ø360	Ø360	Ø480	Ø480	Ø480	Ø480
	Max. load held between center	kg	150	150	150	250	150	150	150	250
	Center distance between spindle & slide table	mm	192	192	192	192	255	255	255	255
Grinding Wheel	Diameter x Width x Bore	mm	Ø510x50-100xØ152.4(6")				Ø510x50-100xØ152.4(6") Opt.Ø610x50 ~ 100xØ203.2(8")			
	Motor rated power / max. torque	Kw/Nm	7.5kw/49Nm(Opt.11Kw/ 71Nm)				7.5kw/49Nm(Opt.11Kw/ 71Nm)			
Workhead	Wheel speed	rpm	1250 (Opt.1650)				1250 (Opt.1650)			
	Swiveling angle	deg	90				90			
	Spindle speed (infinite variable)	rpm	10 ~ 600				10 ~ 600			
	Motor rated power / max. torque	kw	1.5				1.5			
	Center taper	-	MT4 (Opt. MT5)				MT4 (Opt. MT5)			
	Spindle type	-	Fixed or Rotary				Fixed or Rotary			
	Diameter of bore	mm	Ø26				Ø26			
Tailstock	Quill travel	mm	25 (Opt.50/75)				25 (Opt.50/75)			
	Center taper	-	MT4 (Opt. MT5)				MT4 (Opt. MT5)			
X Axis	Travel	mm	280				280			
	Max. rapid feedrate	m/min	6				6			
	Heidenhain linear scale resolution	um	0.05				0.05			
	Min. increment	mm	0.0001				0.0001			
	Servo motor rated power	kw	1.8(F)/2.2(M)				1.8(F)/2.2(M)			
Z Axis	Travel	mm	900	1300	1950	2450	900	1300	1950	2450
	Swiveling angle	deg	±9	±7	±5	±5	±9	±7	±5	±5
	Max. rapid feedrate	m/min	10				10			
	Min. increment	mm	0.0001				0.0001			
	Servo motor rated power	kw	1.8(F)/2.2(M) 2.5(F)/3.5(M)				1.8(F)/2.2(M) 2.5(F)/3.5(M)			
Motor	Hydraulic pump	kw	0.38				0.38			
	Hydrodynamic GW spindle lubrication pump	kw	0.2				0.2			
	Guide way lubrication pump	kw	0.2				0.2			
	Coolant pump	kw	0.2				0.2			
Machine	Net Weight (semi-enclosed splash guard)	kg	5700	6000	6400	6800	5800	6100	6500	6900
	Gross Weight	kg	6500	6800	7200	7600	6600	6900	7300	7700

Measurement

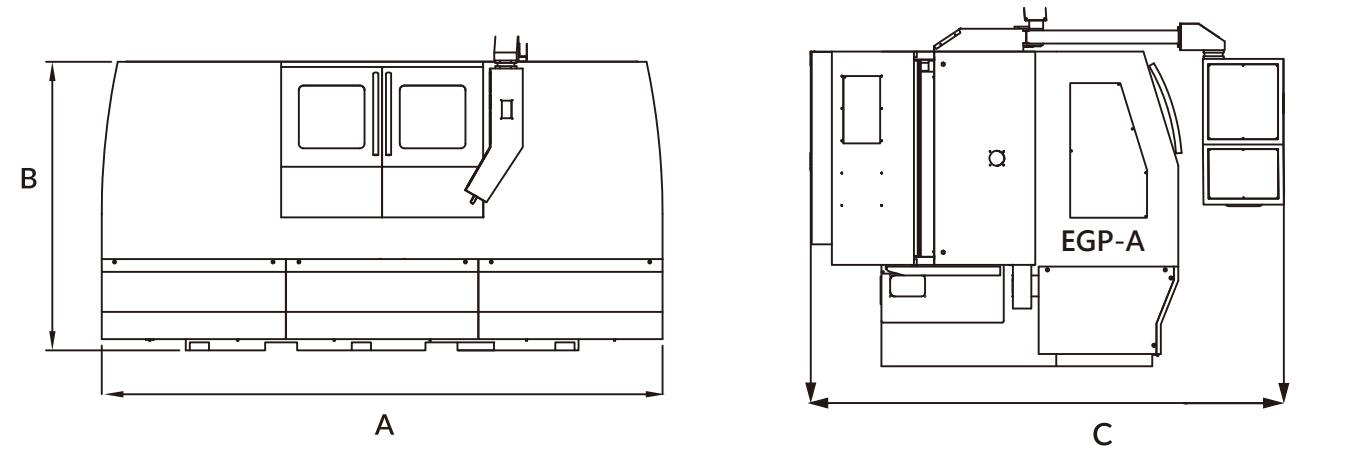

EGP-A	A	B	C	D	E	F	G	H	I
3860	3500	1800	2760	1270	1010	585	385	480	1000
38100	4300	1800	2760	1670	1410	985	725	480	1000
38150	5600	1800	2760	2270	2010	1325	1585	480	1000
38200	7055	1800	2850	2890	2630	1945	2205	560	1000
5060	3500	1800	2760	1270	1010	585	385	480	1000
50100	4300	1800	2760	1670	1410	985	725	480	1000
50150	5600	1800	2760	2270	2010	1325	1585	480	1000
50200	7055	1800	2850	2890	2630	1945	2205	560	1000

