

ROYAL
Royal Precision Tools Corporation

High Precision Spindles Solutions

Total Solution • State of the Art



PRECISION

STABILITY

RIGIDITY

EFFICIENCY

Belt-Drive Spindle

- ▶ High precision, high rigidity
- ▶ Easy repair, simple maintenance



Model	Housing OD (mm)	Max. Speed (rpm)	Taper	Clamping force (kgf)	Bearing ID (mm)	Lubrication	Cooling	Weight (kg)	CTS
RB3002	Ø100	15000	BT30/BBT30	300±50	Ø50	Grease	Oil	Approx. 17	Optional
RB3021	Ø120	15000	BT30/BBT30	300±50	Ø60			Approx. 20	
RB4006		12000	BT40/BBT40	700±50	Ø60			Approx. 33	
RB4388	Ø150	12000	BT40/BBT40	1000±100	Ø70			Approx. 56	
RBH004			HSK A63	1800~2300	Ø70			Approx. 56	
RB4078	Ø155	12000	BT40/BBT40	1000±100	Ø70			Approx. 60	
RBH018			HSK A63	1800~2300	Ø70			Approx. 60	
RB5233			8000	BT50/BBT50	1500±100			Ø80	
RB5004	Ø190	10000	BT50/BBT50	1800±100	Ø100			Approx. 123	
RB5242	Ø200	10000	BT50/BBT50	1800±100	Ø100			Approx. 130	

RB3002

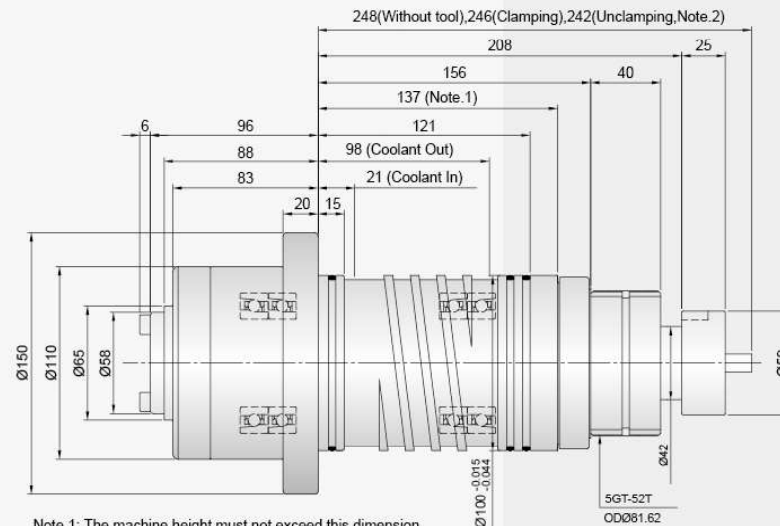
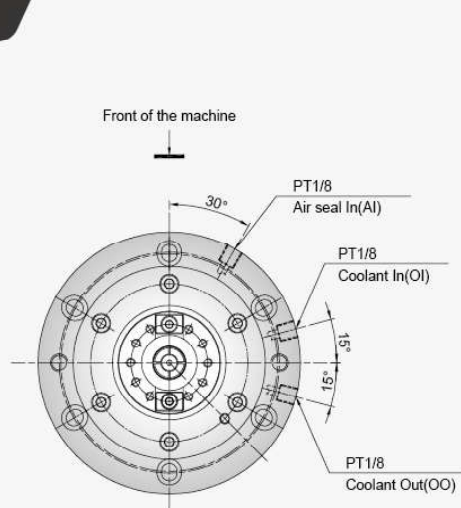

Note.1: The machine height must not exceed this dimension.
 Note.2: including an ejection of 0.5mm.

RB4006

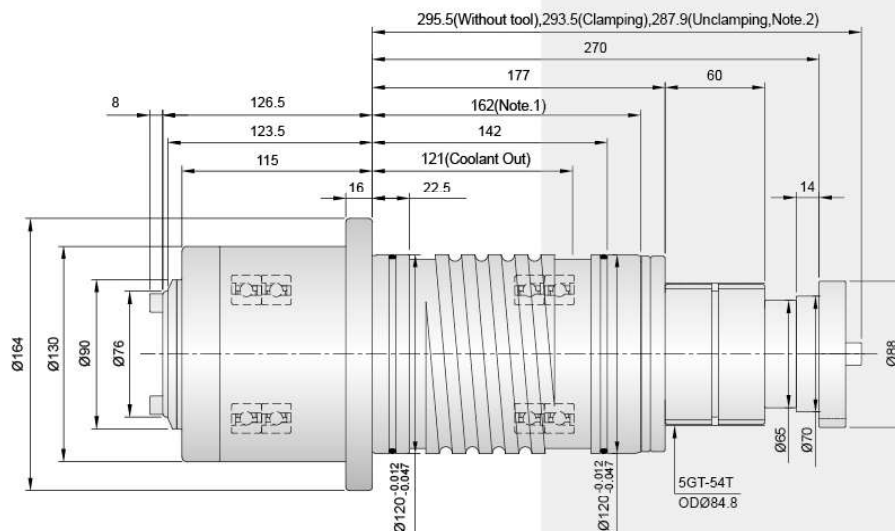
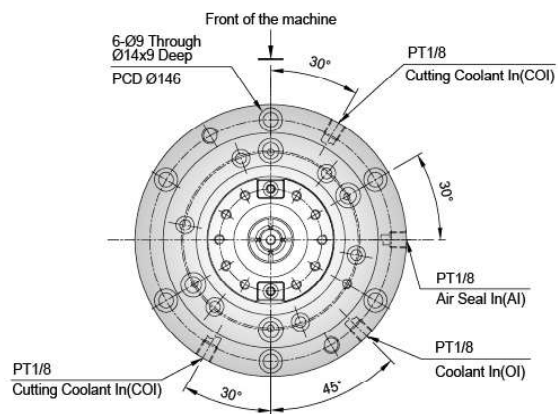

Note.1: The machine height must not exceed this dimension.
 Note.2: including an ejection of 0.6mm.

RB4388

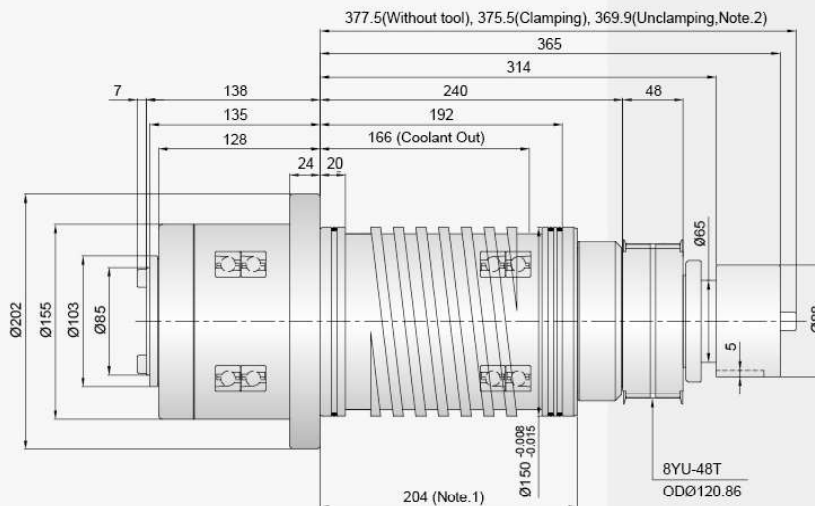
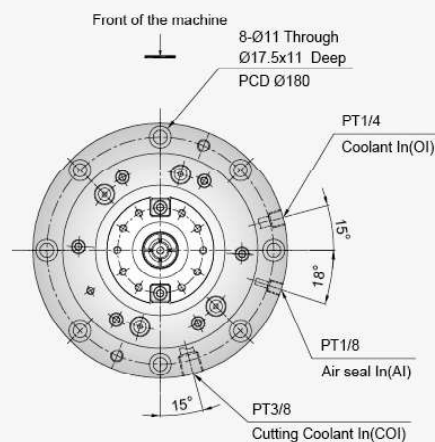

Note.1: The machine height must not exceed this dimension.
Note.2: including an ejection of 0.6mm.

RB4078

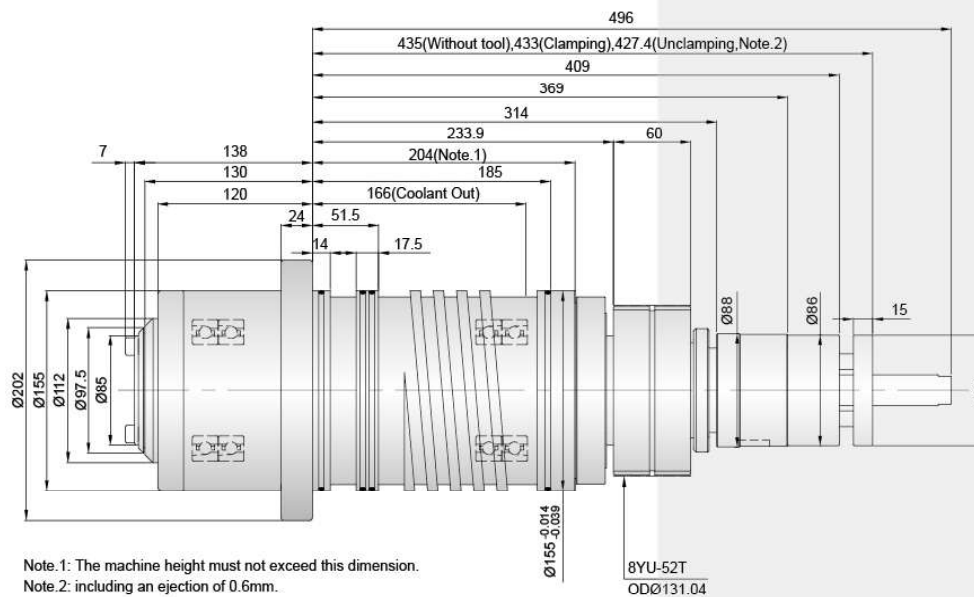
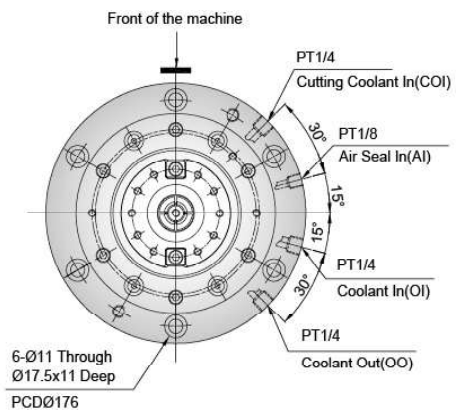

Note.1: The machine height must not exceed this dimension.
Note.2: including an ejection of 0.6mm.

RB5233

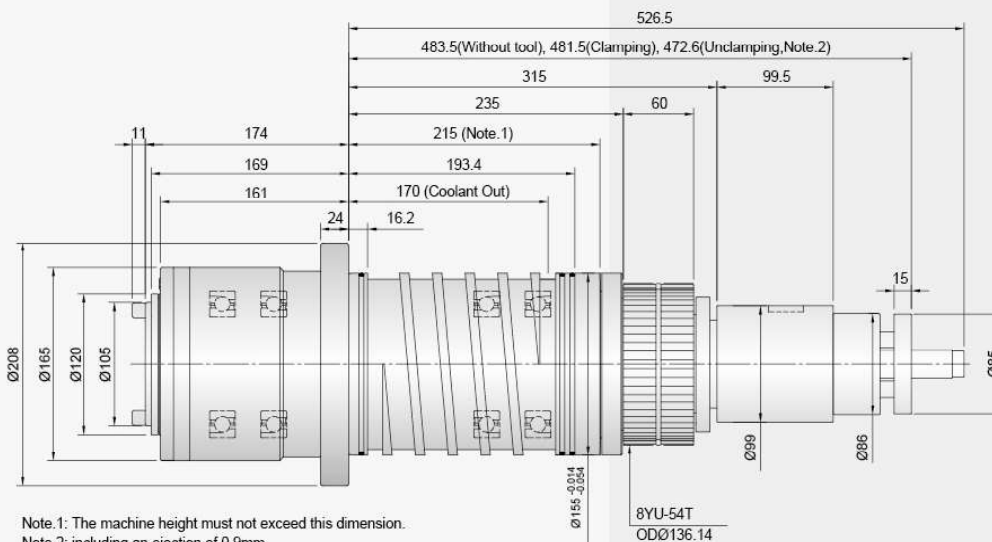
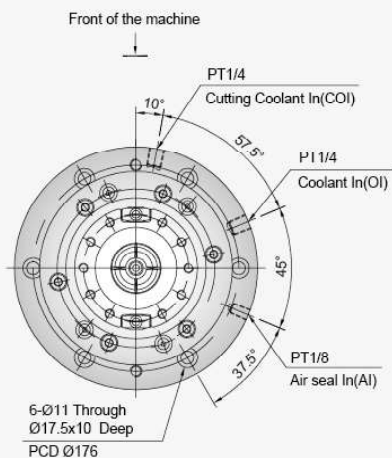

Note.1: The machine height must not exceed this dimension.
Note.2: including an ejection of 0.9mm.

RB5004

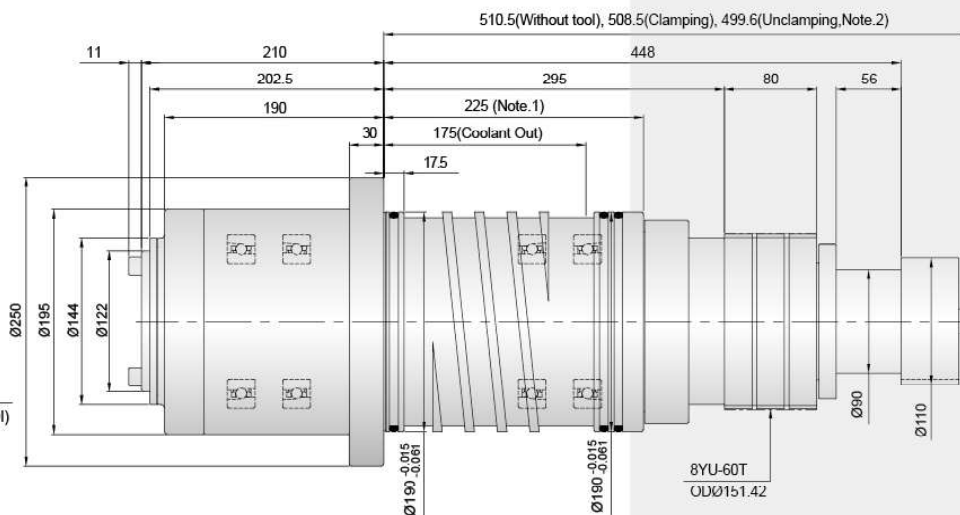
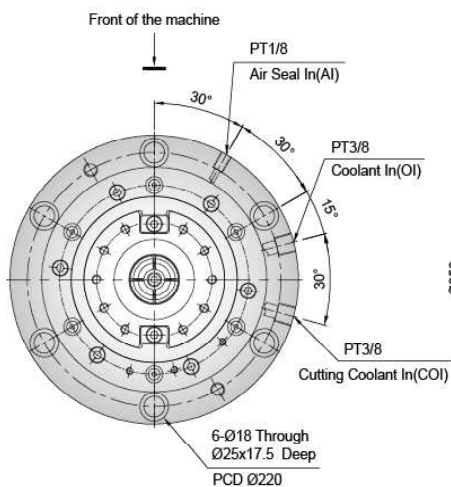

Note.1: The machine height must not exceed this dimension.
Note.2: including an ejection of 0.9mm.

Your Spindle Solutions
Speed, Precision, Rigidity

ROYAL

Royal Precision Tools Corporation

Head office

No. 21, Sec. 1, Zhongshan Rd., Wuri Dist.,
Taichung City 414, Taiwan

TEL: +886 4 2338 2068

FAX: +886 4 2338 2161

E-mail : royal_sa@royal-spindles.com.tw

Jiji, Nantou

No. 66, Zhongji Rd., Jiji Township,
Nantou County 552, Taiwan

TEL: +886 4 2338 2068

FAX: +886 49 276 2812



www.royal-spindles.com