

h100-B72 大孔徑搪孔刀組合系統 

Large Diameter Boring System

h100-B72

大孔徑搪孔刀組合系統 Large Diameter Boring System

- 搪孔刀柄 Taper Shank
- 延長接桿 Extension Spacer
- 接盤 Adapter
- 變徑滑座 Plate
- 大孔徑粗搪孔刀本體 Large Diameter Body
- 粗搪孔刀座 Cutting Insert Holder
- 80°粗搪孔刀座 80° Cutting Insert Holder
- 45°正反倒角粗搪孔刀座 45° Chamfer Cutting Insert Holder
- 粗搪孔反搪刀座 Reverse Cutting Insert Holder
- 大孔徑精搪孔刀本體 Large Diameter Body
- 平衡座 Balance Holder
- 精搪孔刀座 Cutting Insert Holder
- 精搪孔反搪刀座 Reverse Cutting Insert Holder

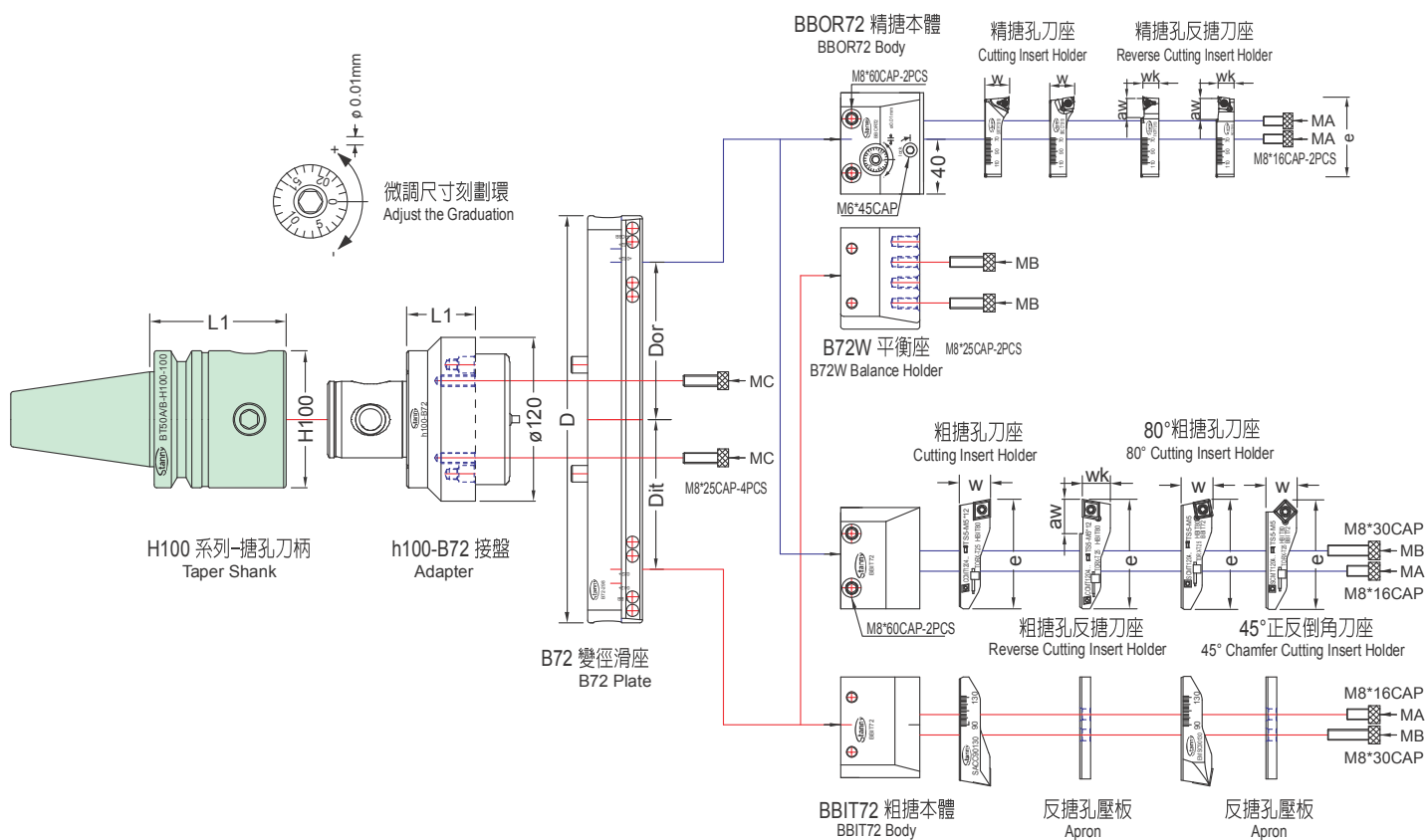

DBT50-H100-100

規格：請參閱P.19
Specification please refer to P.19



DIN69871A
ISO50-H100-100

規格：請參閱P.23
Specification please refer to P.23



h100H100-100

規格：請參閱P.26
Specification please refer to P.26

h100-B72

大孔徑搪孔刀組合系統 Large Diameter Boring System

搪孔刀柄 Taper Shank
延長接桿 Extension Spacer

■ 接盤 Adapter

■ 變徑滑座 Plate

大孔徑粗搪孔刀本體 Large Diameter Body

粗搪孔刀座 Cutting Insert Holder

80°粗搪孔刀座 80° Cutting Insert Holder

45°正反倒角粗搪孔刀座 45° Chamfer Cutting Insert Holder

粗搪孔反搪刀座 Reverse Cutting Insert Holder

大孔徑精搪孔刀本體 Large Diameter Body

平衡座 Balance Holder

精搪孔刀座 Cutting Insert Holder

精搪孔反搪刀座 Reverse Cutting Insert Holder

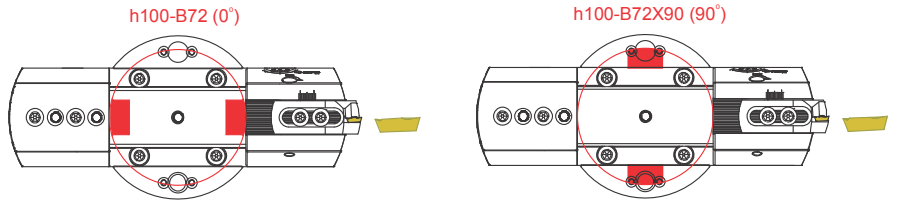
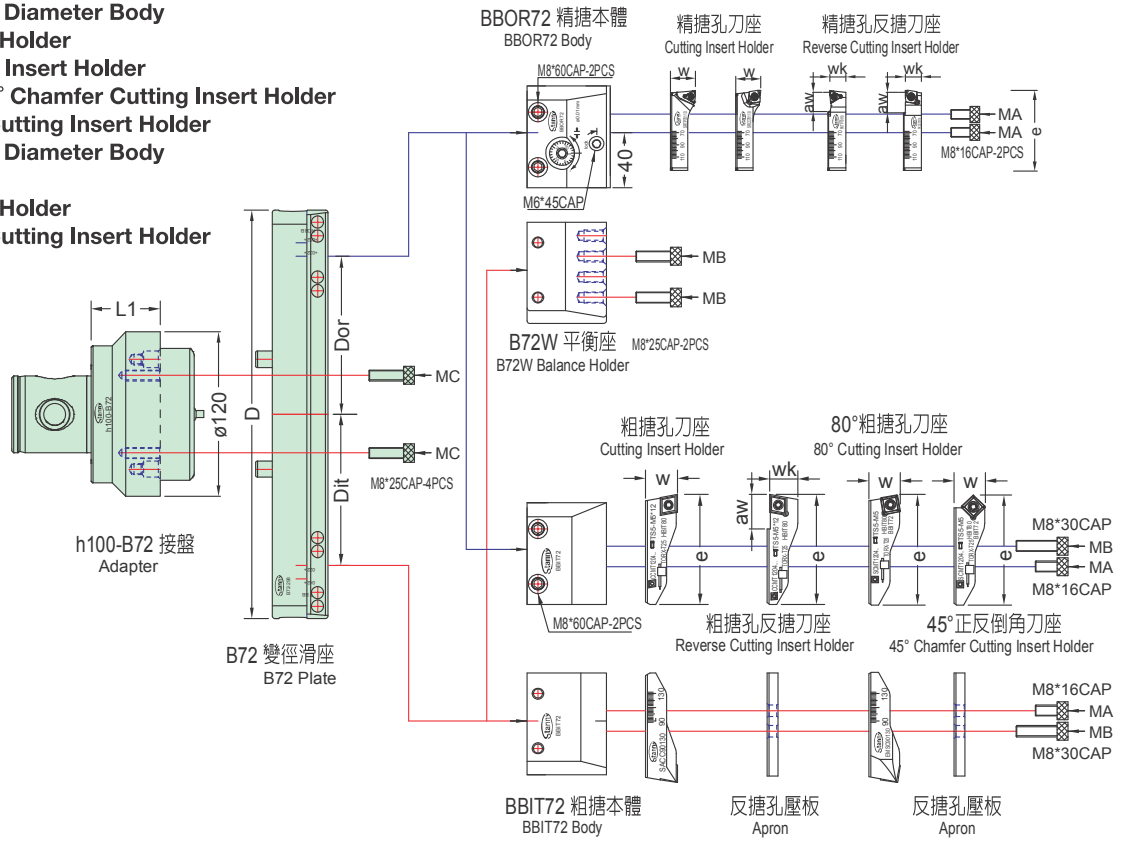

h100-B72接盤 Adapter for BBIT and BBOR Large Diameter Boring System

訂貨編號 Order No.	規格 Model	L1	MC螺絲 MC Bolt	淨重 N.W.
41720000	h100-B72	50	CAP M8x25-4PCS	4.80
41720000x9	h100-B72x90°	50	CAP M8x25-4PCS	4.80



B72 變徑滑座 Plate for BBIT and BBOR Large Diameter Boring System

訂貨編號 Order No.	規格 Model	長度 D	BBOR Dor	BBIT Dit	淨重 N.W.
70172148	B72-148	148	40	35	2.15
70272198	B72-198	198	65	60	3.00
70372248	B72-248	248	90	85	3.80
70472298	B72-298	298	115	110	4.60
70572348	B72-348	348	140	135	5.40
70672398	B72-398	398	165	160	6.20

註:變徑滑座設有兩組測孔,相距10mm,可增加ø20mm搪孔範圍,使搪孔範圍更附彈性。
Remark: Plate has four holes, distance 10mm and the boring range increase ø20mm.

搪孔刀柄 Taper Shank
 延長接桿 Extension Spacer
 接盤 Adapter
 變徑滑座 Plate

- 大孔徑粗搪孔刀本體 Large Diameter Body
- 粗搪孔刀座 Cutting Insert Holder
- 粗搪孔反搪刀座 Reverse Cutting Insert Holder
- 80°粗搪孔刀座 80° Cutting Insert Holder
- 45°正反倒角粗搪孔刀座 45° Chamfer Cutting Insert Holder

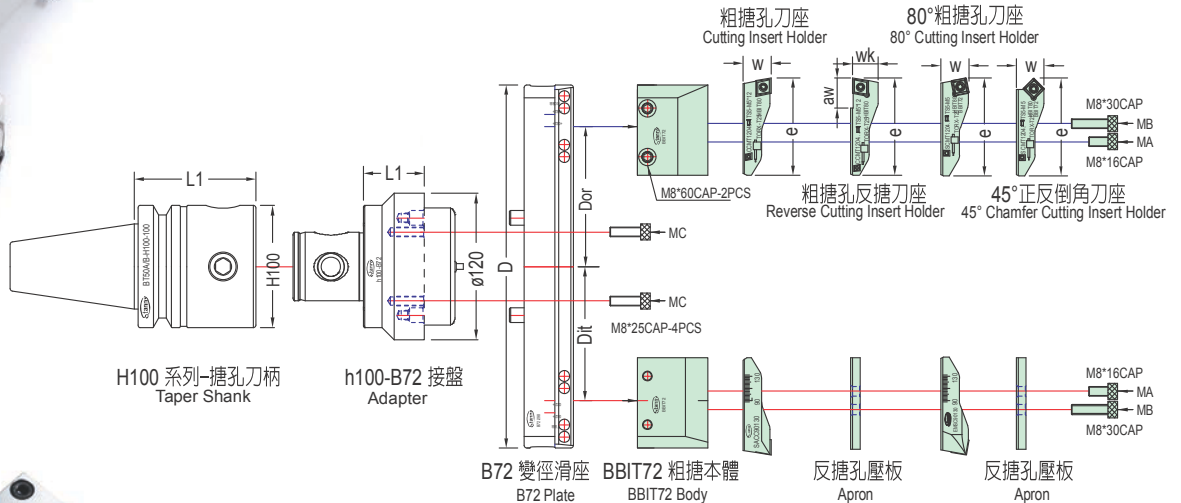

B72 變徑滑座 B72 Plate

訂貨編號 Order No.	規格 Model	移動量 Mobile	MA Bolt	MB Bolt	扳手 Wrench	淨重 N.W.
70007372	B72	20	M8x16	M8x30	六角 4 六角 6	1.44

B72 粗搪孔刀座 Cutting Insert Holder for BBIT Large Diameter Adjustable Twin Cutter Roughing

訂貨編號 Order No.	規格 Model	W	e	刀片 Insert	螺絲 Bolt	扳手 Wrench	淨重 N.W.
30809013A	SACC90130	22.6	79.5	CCMT1204..	TS5-M5	T25	0.17
30809013B	SBCC90130		0.18				
30813017A	SACC130170		0.23				
30813017B	SBCC130170		0.24				

B72 粗搪孔反搪刀座 Reverse Cutting Insert Holder for BBIT Large Diameter Adjustable Single Cutter Roughing

訂貨編號 Order No.	規格 Model	aw	wk	e	刀片 Insert	螺絲 Bolt	扳手 Wrench	淨重 N.W.
30809013K	RKCC90130	22	22	79.5	CCMT1204..	TS5-M5	T25	0.18
30813017K	RKCC130170	44	22	99.5				0.25

B72 80°粗搪孔刀座 80° Cutting Insert Holder for BBIT Adjustable Twin Cutter Roughing

訂貨編號 Order No.	規格 Model	W	e	刀片 Insert	螺絲 Bolt	扳手 Wrench	淨重 N.W.
30809013M	EMSC90130	23.1	80.5	SCMT1204..	TS5-M5	T25	0.17
30813017M	EMSC130170		100.5				0.23

B72 45°正反倒角粗搪孔刀座 45° Chamfer Cutting Insert Holder for BBIT Adjustable Single Cutter Roughing

訂貨編號 Order No.	規格 Model	W	e	刀片 Insert	螺絲 Bolt	扳手 Wrench	淨重 N.W.
30809013W	IWSC90130	23.1	80.5	SCMT1204..	TS5-M5	T25	0.16
30813017W	IWSC130170		100.5				0.22

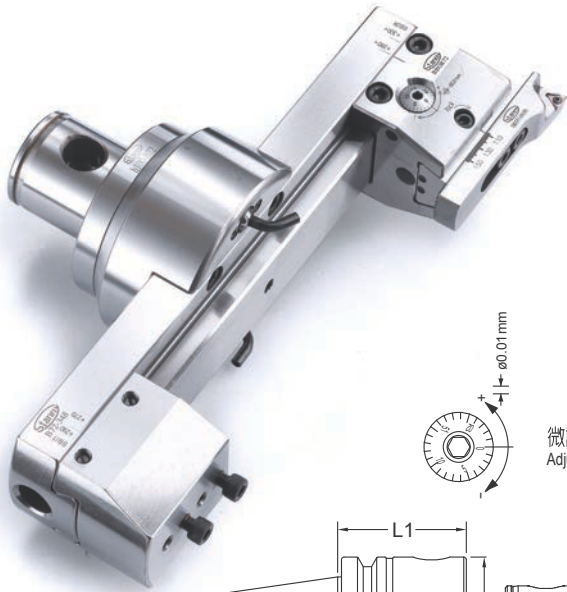

搪孔刀柄 Taper Shank
 延長接桿 Extension Spacer
 接盤 Adapter
 變徑滑座 Plate

- 大孔徑精搪孔刀本體 Large Diameter Body
- 平衡座 Balance Holder
- 精搪孔刀座 Cutting Insert Holder
- 菱形精搪孔刀座 Rhombus Cutting Insert Holder
- 精搪孔反搪刀座 Reverse Cutting Insert Holder
- 菱形精搪孔反搪刀座 Rhombus Reverse Cutting Insert Holder

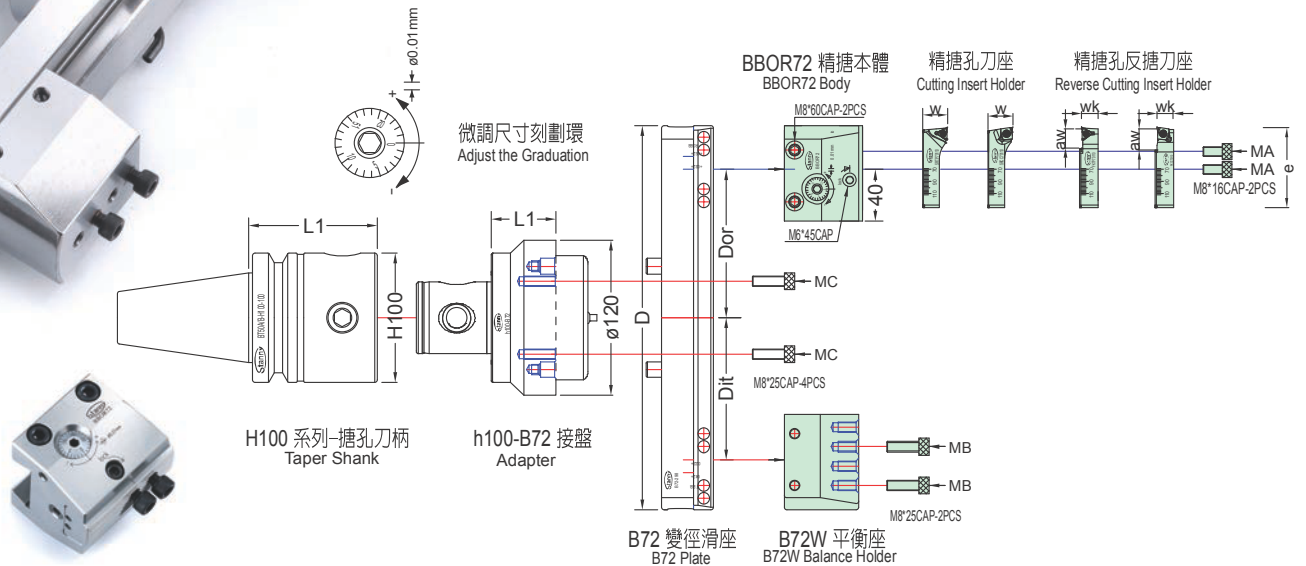

BBOR72 大孔徑微調精搪孔本體+B72W平衡座 Body and Balance Holder for Large Diameter Finishing Cutter Fine Boring System

訂貨編號 Order No.	規格 Model	移動量 Mobile	MA Bolt	MB Bolt	板手 Wrench	淨重 N.W.
70007572	BBOR72	28.5	M8x16	M8x25	○ 5 ○ 6	1.65
70007472	B72W					1.59

BBOR72 精搪孔刀座 Cutting Insert Holder for BBOR Large Diameter Finishing Cutter Fine Boring System

訂貨編號 Order No.	規格 Model	W	e	刀片 Insert	螺絲 Bolt	板手 Wrench	淨重 N.W.
50637011	SRTP70110	20	66	TPGH1103..L	SB-3TR-M3	T8	0.10
50637115	SRTP110150	20	106				0.21

BBOR72 菱形精搪孔刀座 Rhombus Cutting Insert Holder for BBOR Large Diameter Finishing Cutter Fine Boring System

訂貨編號 Order No.	規格 Model	W	e	刀片 Insert	螺絲 Bolt	板手 Wrench	淨重 N.W.
50637011CC	SRCC70110	20	67	CCGT09T3..L	TS4-M4	T15	0.10
50637115CC	SRCC110150	20	107				0.20

BBOR72 精搪孔反搪刀座 Reverse Cutting Insert Holder for BBOR Large Diameter Finishing Cutter Fine Boring System

訂貨編號 Order No.	規格 Model	aw	wk	e	刀片 Insert	螺絲 Bolt	板手 Wrench	淨重 N.W.
50637011K	FKTP70110	16	15	66	TPGH1103..R	SB-3TR-M3	T8	0.10
50637115K	FKTP110150	25	15	106				0.21

BBOR72 菱形精搪孔反搪刀座 Rhombus Reverse Cutting Insert Holder for BBOR Large Diameter Finishing Cutter Fine Boring System

訂貨編號 Order No.	規格 Model	aw	wk	e	刀片 Insert	螺絲 Bolt	板手 Wrench	淨重 N.W.
50637011KC	FKCC70110	16	15	67	CCGT09T3..R	TS4-M4	T15	0.10
50637115KC	FKCC110150	28	15	107				0.20

BBIT72

大孔徑雙刃粗搪孔刀組合系統-AB type

Large Diameter Adjustable Twin Cutter Roughing and Semi-Finishing Boring System

搪孔刀柄、接盤、變徑滑座、大孔徑粗搪孔刀本體、粗搪孔刀座

Taper Shank, Adapter, Plate, Large Diameter Body and Cutting Insert Holder

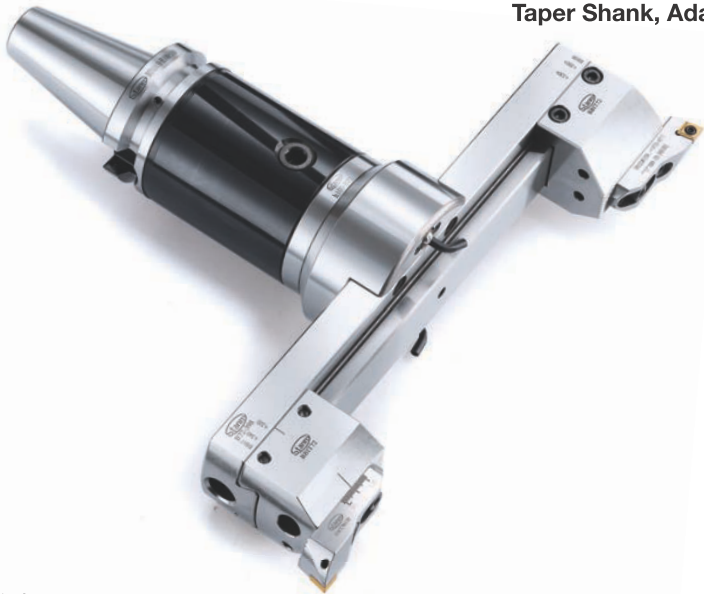

整支 SET

MAS403 DBT-BBIT72 大孔徑雙刃粗搪孔刀-AB type

MAS403 DBT and BBIT72 Large Diameter Adjustable Twin Cutter Roughing and Semi-Finishing Boring System

訂貨編號 Order No.	規 格 Model	範 圍 D Boring Range øDMin-øDMax	M	L	大孔徑粗搪孔系統組合 Large Diameter Adjustable Twin Cutter Boring System					淨 重 N.W.	
					搪孔刀柄 Taper Shank	接 盤 Adapter	變徑滑座 Plate	大孔徑粗搪孔刀本體 Boring Head	粗搪孔刀座 Cutting Insert Holder		
83108520AB	DBT50-BBIT72-202	AB 160-220	202	245	DBT50-H100-100			B72-148		SACC90130 SBCC90130	16.13
83208520AB	DBT50-BBIT72-202	AB 210-270						B72-198			16.98
83308520AB	DBT50-BBIT72-202	AB 260-320						B72-248			17.78
83408520AB	DBT50-BBIT72-202	AB 310-370						B72-298			18.58
83508520AB	DBT50-BBIT72-202	AB 360-420						B72-348			19.38
83608520AB	DBT50-BBIT72-202	AB 410-470						B72-398			20.18
83118520AB	DBT50-BBIT72-202	AB 200-260						B72-148			16.25
83218520AB	DBT50-BBIT72-202	AB 250-310						B72-198			17.10
83318520AB	DBT50-BBIT72-202	AB 300-360						B72-248			17.90
83418520AB	DBT50-BBIT72-202	AB 350-410						B72-298			18.70
83518520AB	DBT50-BBIT72-202	AB 400-460						B72-348			19.50
83618520AB	DBT50-BBIT72-202	AB 450-510						B72-398			20.30
83108525AB	DBT50-BBIT72-252	AB 160-220	252	295	DBT50-H100-150	h100-B72	BBIT72	B72-148	SACC90130 SBCC90130	18.78	
83208525AB	DBT50-BBIT72-252	AB 210-270						B72-198		19.63	
83308525AB	DBT50-BBIT72-252	AB 260-320						B72-248		20.43	
83408525AB	DBT50-BBIT72-252	AB 310-370						B72-298		21.23	
83508525AB	DBT50-BBIT72-252	AB 360-420						B72-348		22.03	
83608525AB	DBT50-BBIT72-252	AB 410-470						B72-398		22.83	
83118525AB	DBT50-BBIT72-252	AB 200-260						B72-148		18.90	
83218525AB	DBT50-BBIT72-252	AB 250-310						B72-198		19.75	
83318525AB	DBT50-BBIT72-252	AB 300-360						B72-248		20.55	
83418525AB	DBT50-BBIT72-252	AB 350-410						B72-298		21.35	
83518525AB	DBT50-BBIT72-252	AB 400-460						B72-348		22.15	
83618525AB	DBT50-BBIT72-252	AB 450-510						B72-398		22.95	
83108530AB	DBT50-BBIT72-302	AB 160-220	302	345	DBT50-H100-200			B72-148	SACC90130 SBCC90130	21.73	
83208530AB	DBT50-BBIT72-302	AB 210-270						B72-198		22.58	
83308530AB	DBT50-BBIT72-302	AB 260-320						B72-248		23.38	
83408530AB	DBT50-BBIT72-302	AB 310-370						B72-298		24.18	
83508530AB	DBT50-BBIT72-302	AB 360-420						B72-348		24.98	
83608530AB	DBT50-BBIT72-302	AB 410-470						B72-398		25.78	
83118530AB	DBT50-BBIT72-302	AB 200-260						B72-148		21.85	
83218530AB	DBT50-BBIT72-302	AB 250-310						B72-198		22.70	
83318530AB	DBT50-BBIT72-302	AB 300-360						B72-248		23.50	
83418530AB	DBT50-BBIT72-302	AB 350-410						B72-298		24.30	
83518530AB	DBT50-BBIT72-302	AB 400-460						B72-348		25.10	
83618530AB	DBT50-BBIT72-302	AB 450-510						B72-398		25.90	

BBOR72

大孔徑微調精搪孔刀組合系統

Large Diameter Finishing Cutter Fine Boring System

搪孔刀柄、接盤、變徑滑座、大孔徑精搪孔刀本體、平衡座、精搪孔刀座
 Taper Shank, Adapter, Plate, Large Diameter Body, Balance Holder and Cutting Insert Holder

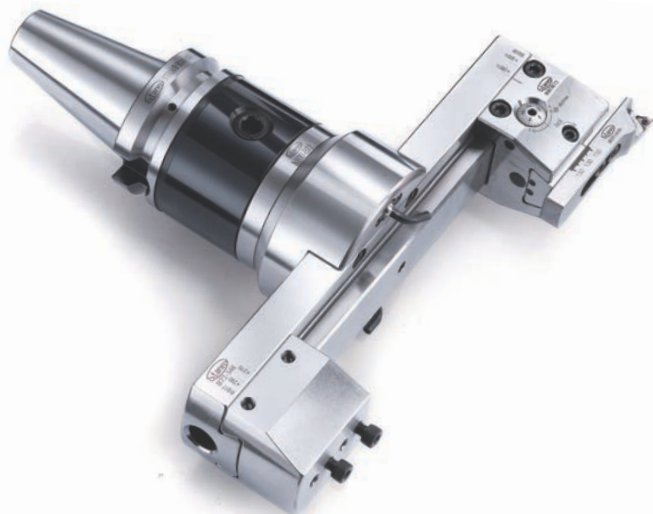

整支 SET

MAS403 DBT-BBOR72 大孔徑微調精搪孔刀

MAS403 DBT and BBOR72 Large Diameter Finishing Cutter Fine Boring System

訂貨編號 Order No.	規格 Model	範圍 D Boring Range øDMin-øDMax	M	L	大孔徑精搪孔系統組合 Large Diameter Finishing Cutter Fine Boring System					淨重 N.W.
					搪孔刀柄 Taper Shank	接盤 Adapter	變徑滑座 Plate	大孔徑精搪孔刀本體 Boring Head	精搪孔刀座 Cutting Insert Holder	
85108520	DBT50-BBOR72-202	M 150-227	202	245	DBT50-H100-100				SRTP70110	16.24
85208520	DBT50-BBOR72-202	M 200-277								17.09
85308520	DBT50-BBOR72-202	M 250-327								17.89
85408520	DBT50-BBOR72-202	M 300-377								18.69
85508520	DBT50-BBOR72-202	M 350-427								19.49
85608520	DBT50-BBOR72-202	M 400-477								20.29
85118520	DBT50-BBOR72-202	M 190-267								16.35
85218520	DBT50-BBOR72-202	M 240-317								17.20
85318520	DBT50-BBOR72-202	M 290-367								18.00
85418520	DBT50-BBOR72-202	M 340-417								18.80
85518520	DBT50-BBOR72-202	M 390-467								19.60
85618520	DBT50-BBOR72-202	M 440-517								20.40
85108525	DBT50-BBOR72-252	M 150-227	252	295	DBT50-H100-150	h100-B72	BBOR72 B72W	SRTP70110	18.89	
85208525	DBT50-BBOR72-252	M 200-277							19.74	
85308525	DBT50-BBOR72-252	M 250-327							20.54	
85408525	DBT50-BBOR72-252	M 300-377							21.34	
85508525	DBT50-BBOR72-252	M 350-427							22.14	
85608525	DBT50-BBOR72-252	M 400-477							22.94	
85118525	DBT50-BBOR72-252	M 190-267							19.00	
85218525	DBT50-BBOR72-252	M 240-317							19.85	
85318525	DBT50-BBOR72-252	M 290-367							20.65	
85418525	DBT50-BBOR72-252	M 340-417							21.45	
85518525	DBT50-BBOR72-252	M 390-467							22.25	
85618525	DBT50-BBOR72-252	M 440-517							23.05	
85108530	DBT50-BBOR72-302	M 150-227	302	345	DBT50-H100-200			SRTP70110	21.84	
85208530	DBT50-BBOR72-302	M 200-277							22.69	
85308530	DBT50-BBOR72-302	M 250-327							23.49	
85408530	DBT50-BBOR72-302	M 300-377							24.29	
85508530	DBT50-BBOR72-302	M 350-427							25.09	
85608530	DBT50-BBOR72-302	M 400-477							25.89	
85118530	DBT50-BBOR72-302	M 190-267							21.95	
85218530	DBT50-BBOR72-302	M 240-317							22.80	
85318530	DBT50-BBOR72-302	M 290-367							23.60	
85418530	DBT50-BBOR72-302	M 340-417							24.40	
85518530	DBT50-BBOR72-302	M 390-467							25.20	
85618530	DBT50-BBOR72-302	M 440-517							26.00	

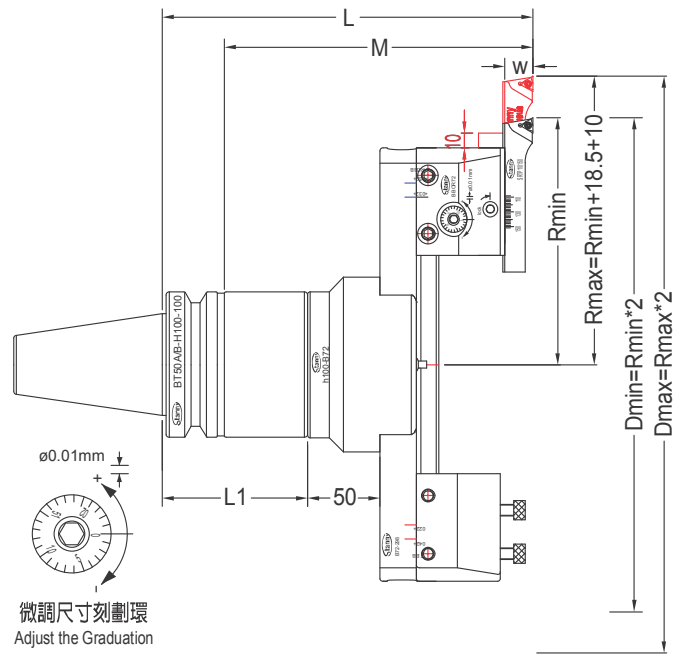

訂貨編號 Order No.	規格 Model	範圍 D Boring Range øDMin-øDMax	M	L	大孔徑精搪孔系統組合 Large Diameter Finishing Cutter Fine Boring System					淨重 N.W.				
					搪孔刀柄 Taper Shank	接盤 Adapter	變徑滑座 Plate	大孔徑精搪孔刀本體 Boring Head	精搪孔刀座 Cutting Insert Holder					
85108535	DBT50-BBOR72-352	M 150-227	352	395	DBT50-H100-250	h100-B72	BBOR72 B72W	SRTP70110	24.79					
85208535	DBT50-BBOR72-352	M 200-277							25.64					
85308535	DBT50-BBOR72-352	M 250-327							26.44					
85408535	DBT50-BBOR72-352	M 300-377							27.24					
85508535	DBT50-BBOR72-352	M 350-427							28.04					
85608535	DBT50-BBOR72-352	M 400-477							28.84					
85118535	DBT50-BBOR72-352	M 190-267							24.90					
85218535	DBT50-BBOR72-352	M 240-317							25.75					
85318535	DBT50-BBOR72-352	M 290-367							26.55					
85418535	DBT50-BBOR72-352	M 340-417							27.35					
85518535	DBT50-BBOR72-352	M 390-467							28.15					
85618535	DBT50-BBOR72-352	M 440-517							28.95					
													SRTP110150	

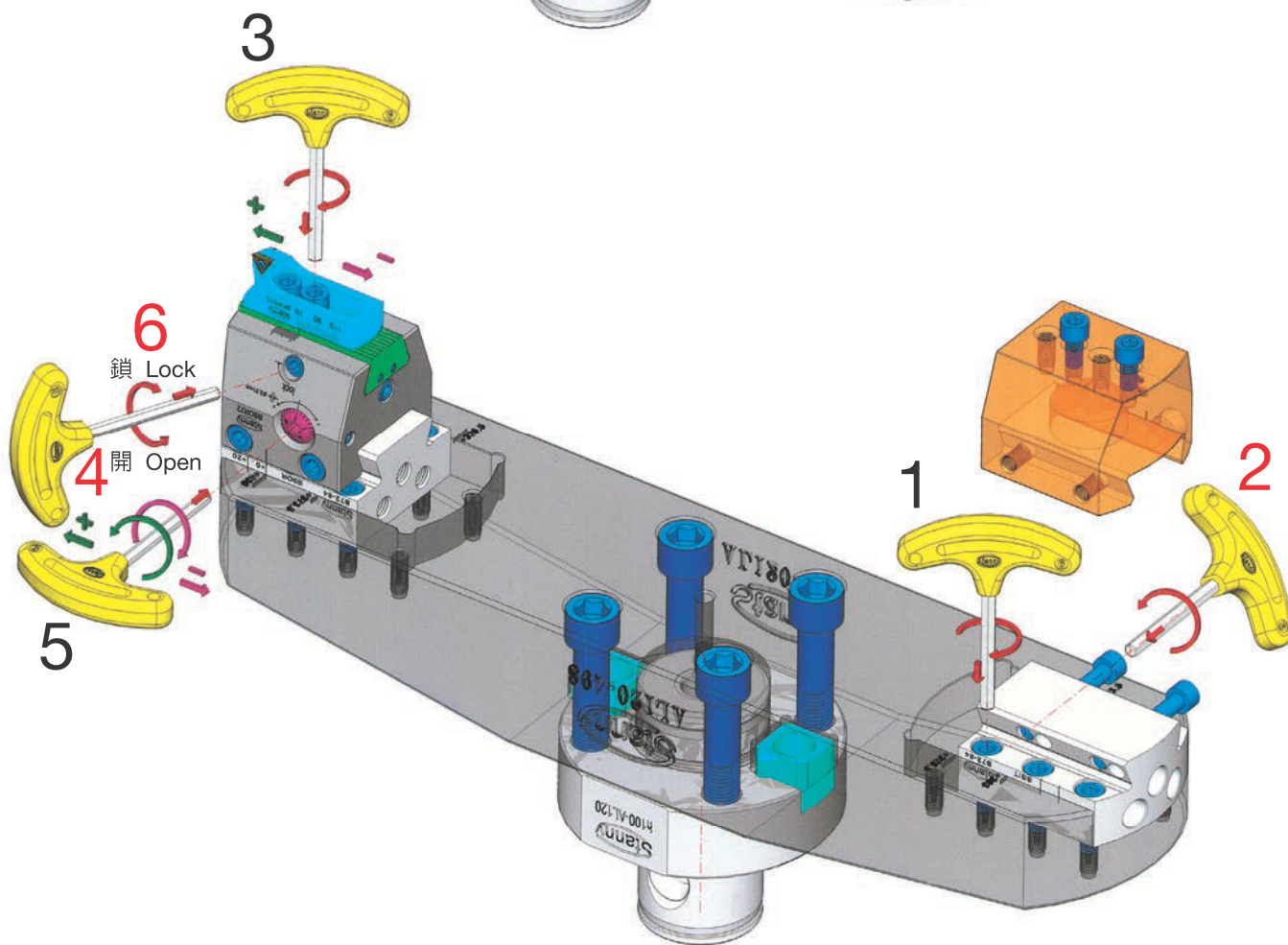
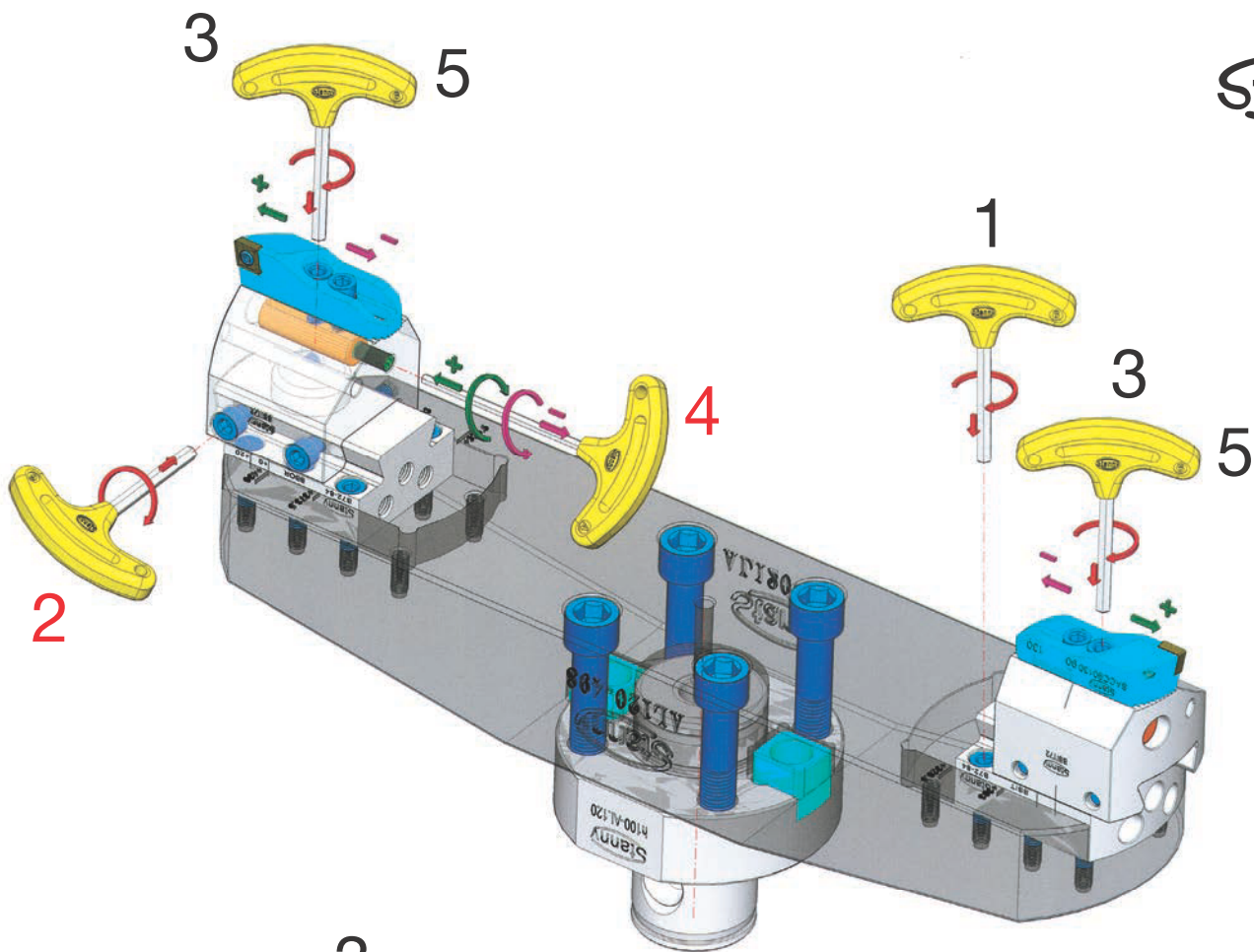

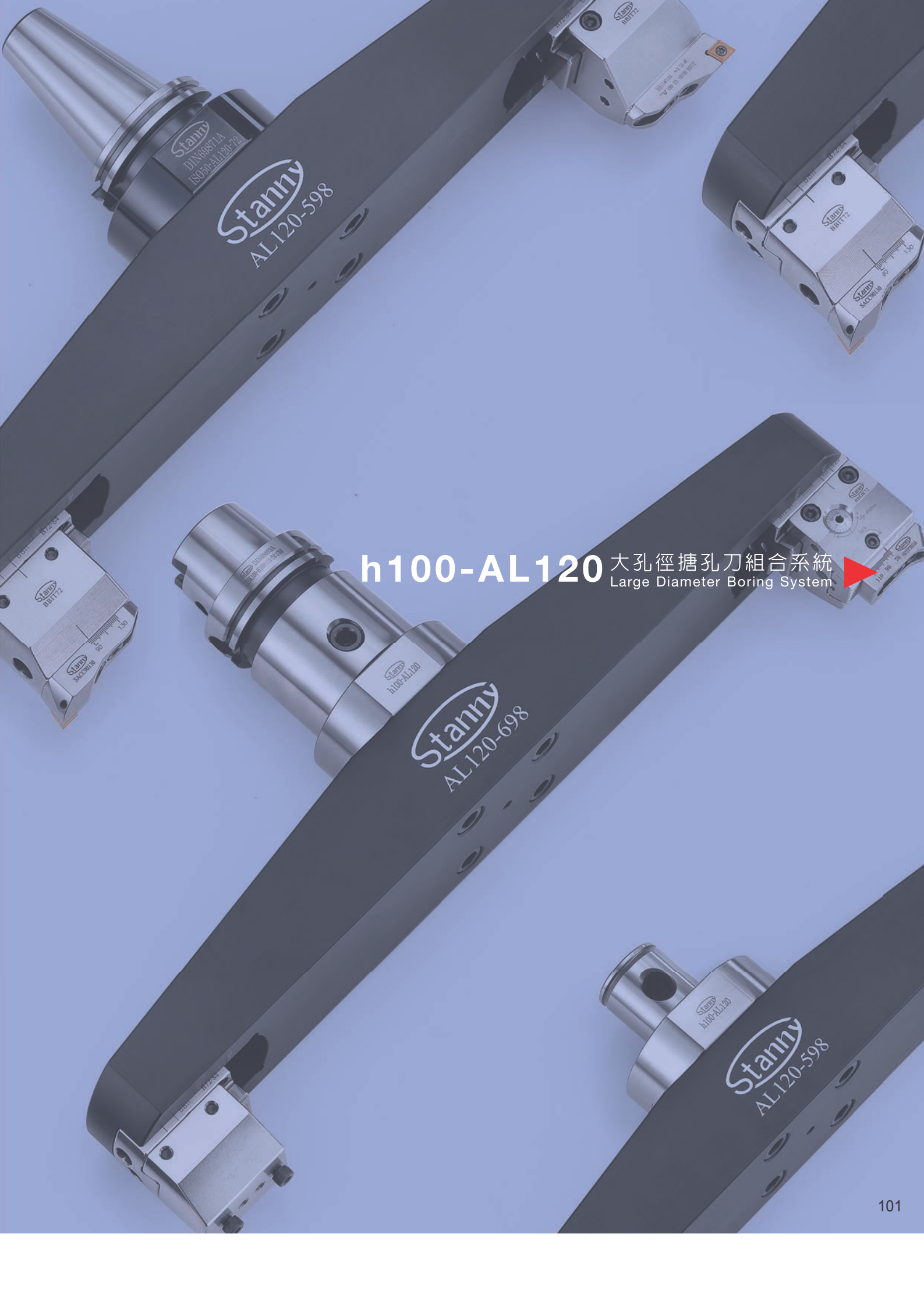

h100-AL120 大孔徑搪孔刀組合系統

Large Diameter Boring System



h100-AL120

大孔徑搪孔刀組合系統 Large Diameter Boring System

- 搪孔刀柄 Taper Shank
- 延長接桿 Extension Spacer
- 接盤 Adapter
- 鋁製滑座 Aluminium Plate
- 滑座 Plate
- 大孔徑粗搪孔刀本體 Large Diameter Body
- 粗搪孔刀座 Cutting Insert Holder
- 80°粗搪孔刀座 80° Cutting Insert Holder
- 45°正反倒角粗搪孔刀座 45° Chamfer Cutting Insert Holder
- 粗搪孔反搪刀座 Reverse Cutting Insert Holder
- 大孔徑精搪孔刀本體 Large Diameter Body
- 平衡座 Balance Holder
- 精搪孔刀座 Cutting Insert Holder
- 菱形精搪孔刀座 Rhombus Cutting Insert Holder
- 精搪孔反搪刀座 Reverse Cutting Insert Holder
- 菱形精搪孔反搪刀座 Rhombus Reverse Cutting Insert Holder

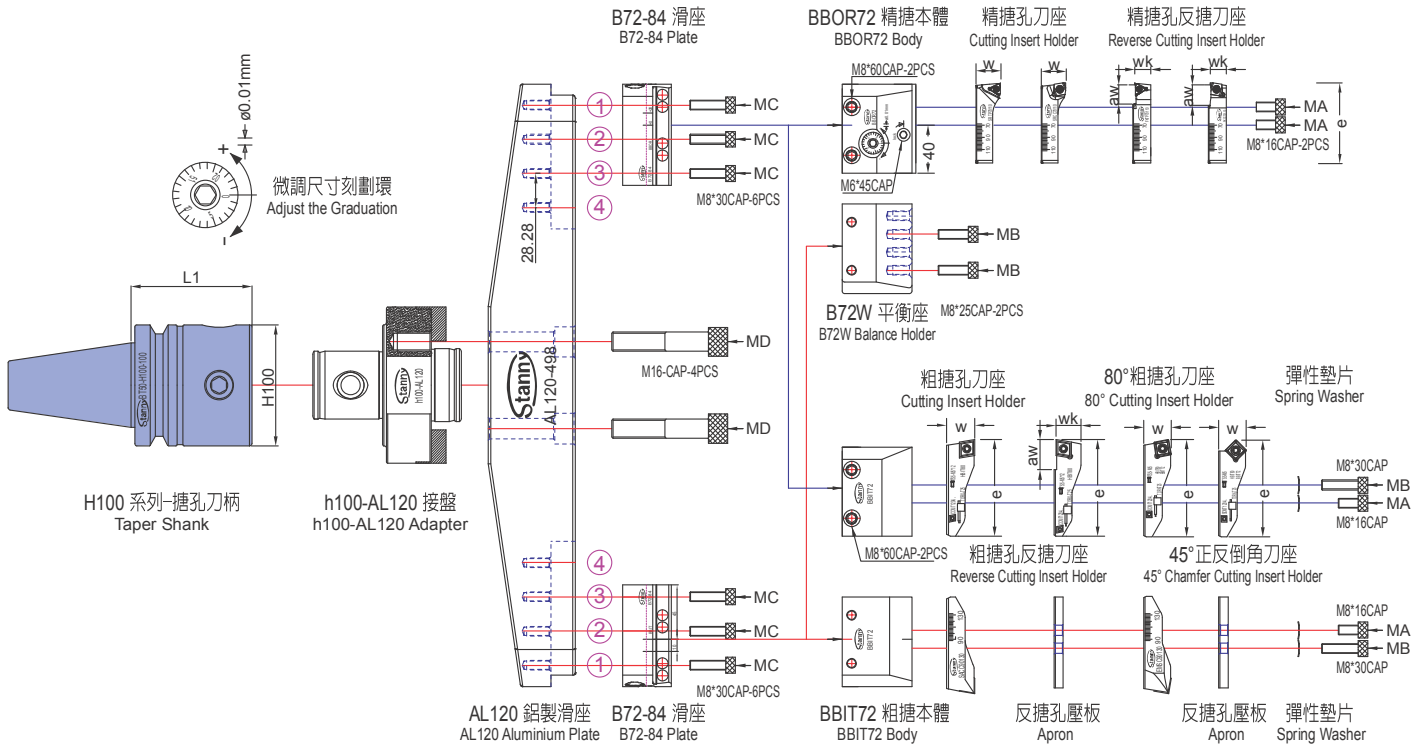

DBT50-H100-100

規格：請參閱P.19
Specification please refer to P.19



DIN69871A
ISO50-H100-100

規格：請參閱P.23
Specification please refer to P.23



h100H100-100

規格：請參閱P.26
Specification please refer to P.26

h100-AL120

大孔徑搪孔刀組合系統 Large Diameter Boring System

搪孔刀柄 Taper Shank
 延長接桿 Extension Spacer
 接盤 Adapter
 鋁製滑座 Aluminium Plate
 滑座 Plate

- 大孔徑粗搪孔刀本體 Large Diameter Body
- 粗搪孔刀座 Cutting Insert Holder
- 80°粗搪孔刀座 80° Cutting Insert Holder
- 45°正反倒角粗搪孔刀座 45° Chamfer Cutting Insert Holder
- 粗搪孔反搪刀座 Reverse Cutting Insert Holder

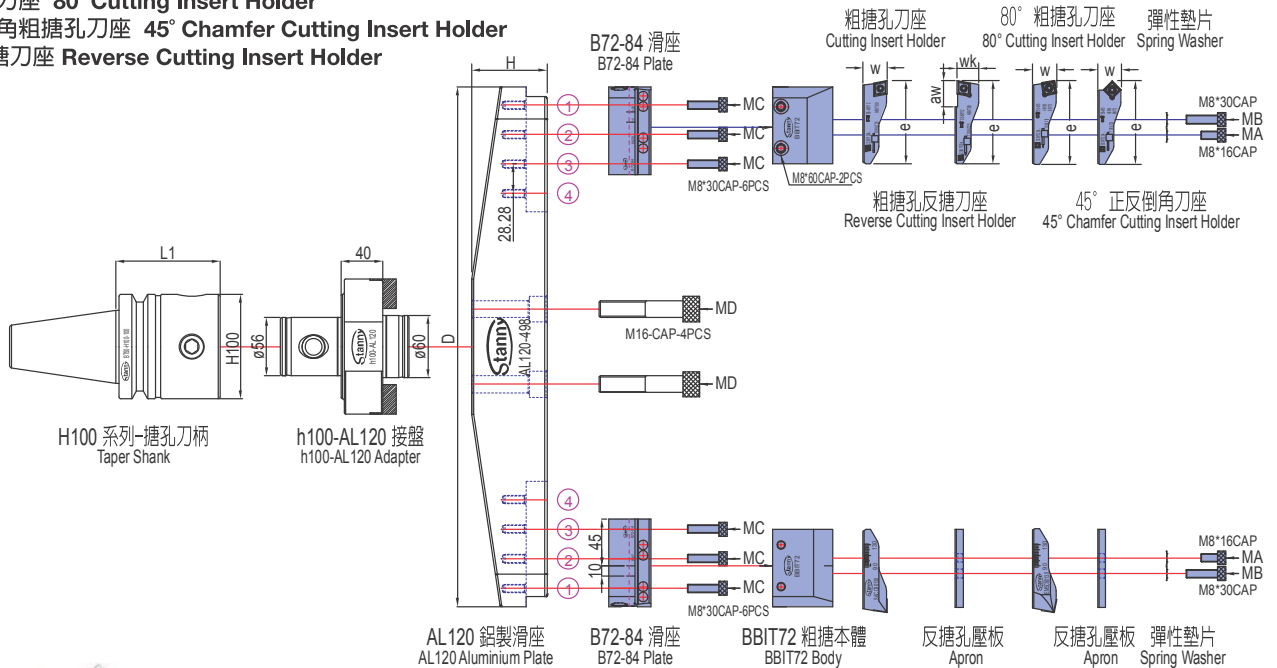

BBIT72 大孔徑粗搪孔本體
Body for Large Diameter Adjustable Twin Cutter Roughing

訂貨編號 Order No.	規格 Model	移動量 Mobile	MA Bolt	MB Bolt	扳手 Wrench	淨重 N.W.
70007372	BBIT72	20	M8x16	M8x30	○ 4 ○ 6	1.44



BBIT72 粗搪孔刀座
Cutting Insert Holder for BBIT Large Diameter Adjustable Twin Cutter Roughing

訂貨編號 Order No.	規格 Model	W	e	刀片 Insert	螺絲 Bolt	扳手 Wrench	淨重 N.W.
30809013A	SACC90130	22.6	79.5	CCMT1204..	TS5-M5	T25	0.17
30809013B	SBCC90130		99.5				0.18
30813017A	SACC130170		0.23				
30813017B	SBCC130170		0.24				



BBIT72 80°粗搪孔刀座
80° Cutting Insert Holder for BBIT Adjustable Twin Cutter Roughing

訂貨編號 Order No.	規格 Model	w	e	刀片 Insert	螺絲 Bolt	扳手 Wrench	淨重 N.W.
30809013M	EMSC90130	23.1	80.5	SCMT1204..	TS5-M5	T25	0.17
30813017M	EMSC130170		100.5				0.23

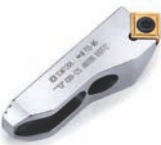

BBIT72 45°正反倒角粗搪孔刀座
45° Chamfer Cutting Insert Holder for BBIT Adjustable Single Cutter Roughing

訂貨編號 Order No.	規格 Model	w	e	刀片 Insert	螺絲 Bolt	扳手 Wrench	淨重 N.W.
30809013W	IWSC90130	23.1	80.5	SCMT1204..	TS5-M5	T25	0.16
30813017W	IWSC130170		100.5				0.22



BBIT72 粗搪孔反搪刀座
Reverse Cutting Insert Holder for BBIT Large Diameter Adjustable Single Cutter Roughing

訂貨編號 Order No.	規格 Model	aw	wk	e	刀片 Insert	螺絲 Bolt	扳手 Wrench	淨重 N.W.
30809013K	RKCC90130	22	22	79.5	CCMT1204..	TS5-M5	T25	0.18
30813017K	RKCC130170	44	22	99.5				0.25

h100-AL120

大孔徑搪孔刀組合系統 Large Diameter Boring System

搪孔刀柄 Taper Shank
延長接桿 Extension Spacer
接盤 Adapter

鋁製滑座 Aluminium Plate

- 大孔徑精搪孔刀本體 Large Diameter Body
- 平衡座 Balance Holder
- 精搪孔刀座 Cutting Insert Holder
- 菱形精搪孔刀座 Rhombus Cutting Insert Holder
- 精搪孔反搪刀座 Reverse Cutting Insert Holder
- 菱形精搪孔反搪刀座 Rhombus Reverse Cutting Insert Holder

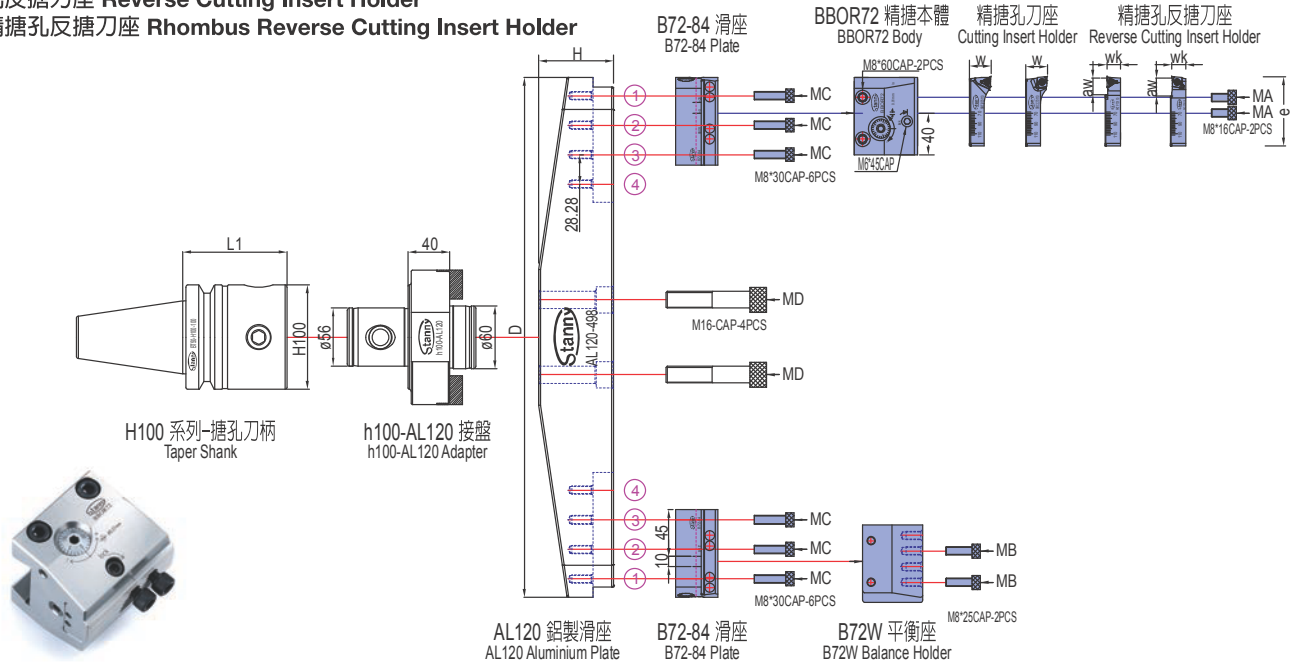

BBOR72 大孔徑微調精搪孔本體+B72W平衡座 Body and Balance Holder for Large Diameter Finishing Cutter Fine Boring System

訂貨編號 Order No.	規格 Model	移動量 Mobile	MA Bolt	MA Bolt	板手 Wrench	淨重 N.W.
70007572	BBOR72	28.5	M8x16		◇ 5 ◇ 6	1.65
70007472	B72W			M8x25		1.59

BBOR72 精搪孔刀座 Cutting Insert Holder for BBOR Large Diameter Finishing Cutter Fine Boring System

訂貨編號 Order No.	規格 Model	W	e	刀片 Insert	螺絲 Bolt	板手 Wrench	淨重 N.W.
50637011	SRTP70110	20	66				0.10
50637115	SRTP110150	20	106	TPGH1103..L	SB-3TR-M3	T8	0.21

BBOR72 菱形精搪孔刀座 Rhombus Cutting Insert Holder for BBOR Large Diameter Finishing Cutter Fine Boring System

訂貨編號 Order No.	規格 Model	W	e	刀片 Insert	螺絲 Bolt	板手 Wrench	淨重 N.W.
50637011CC	SRCC70110	20	67				0.10
50637115CC	SRCC110150	20	107	CCGT09T3..L	TS4-M4	T15	0.20

BBOR72 精搪孔反搪刀座 Reverse Cutting Insert Holder for BBOR Large Diameter Finishing Cutter Fine Boring System

訂貨編號 Order No.	規格 Model	aw	wk	e	刀片 Insert	螺絲 Bolt	板手 Wrench	淨重 N.W.
50637011K	FKTP70110	16	15	66				0.10
50637115K	FKTP110150	25	15	106	TPGH1103..R	SB-3TR-M3	T8	0.21

BBOR72 菱形精搪孔反搪刀座 Rhombus Reverse Cutting Insert Holder for BBOR Large Diameter Finishing Cutter Fine Boring System

訂貨編號 Order No.	規格 Model	aw	wk	e	刀片 Insert	螺絲 Bolt	板手 Wrench	淨重 N.W.
50637011KC	FKCC70110	16	15	67				0.10
50637115KC	FKCC110150	28	15	107	CCGT09T3..R	TS4-M4	T15	0.20

AL-BBIT72

大孔徑雙刃粗搪孔刀組合系統--AB type

Large Diameter Adjustable Twin Cutter Roughing and Semi-Finishing Boring System

搪孔刀柄、接盤、鋁製滑座、大孔徑粗搪孔刀本體、粗搪孔刀座
 Taper Shank, Adapter, Aluminium Plate, Large Diameter Body and Cutting Insert Holder

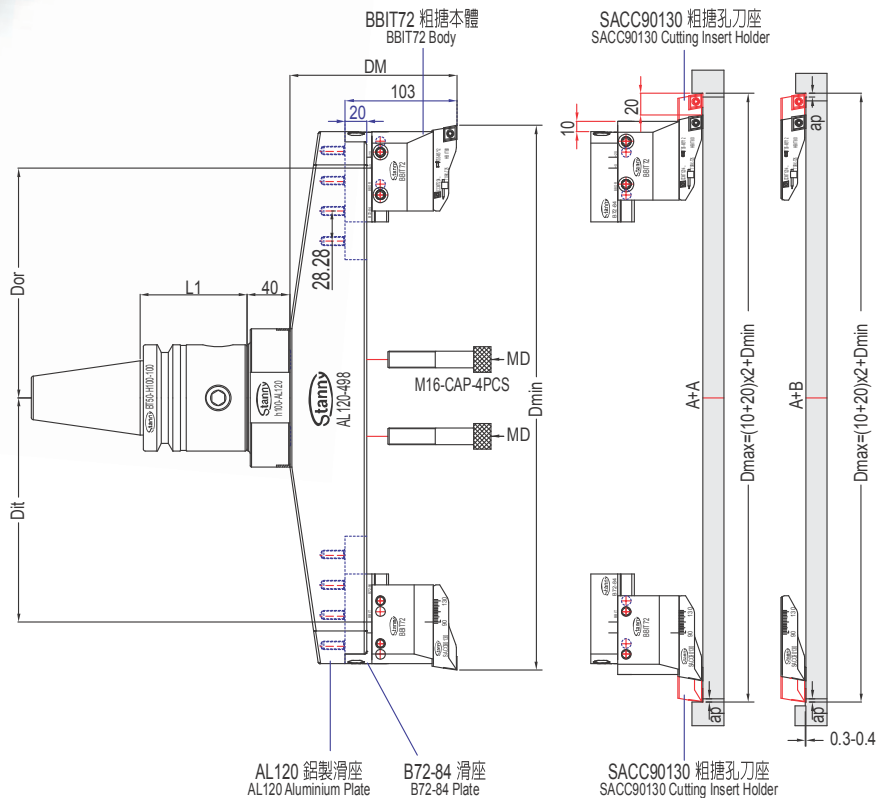

訂貨編號 Order No.	規格 Model	範圍 D Boring Range øDMin-øDMax	深度 DM	大孔徑粗搪孔系統組合 Large Diameter Adjustable Twin Cutter Boring System					淨重 N.W.
				搪孔刀柄 Taper Shank	鋁製滑座 Aluminium Plate	滑座 Plate	大孔徑粗搪孔本體 Boring Head	粗搪孔刀座 Cutting Insert Holder	
93310000AB	AL-BBIT72 AB	410-470	150	DBT50-H100 (P.19) + h100-AL120 (P.103) BT50-AL120 (P.108)	AL120-398	B72-84	BBIT72	SACC90130 SBCC90130	12.00
93410000AB	AL-BBIT72 AB	510-570	155		AL120-498				14.40
93510000AB	AL-BBIT72 AB	610-670	160		AL120-598				16.91
93610000AB	AL-BBIT72 AB	710-770	165		AL120-698				19.41
93710000AB	AL-BBIT72 AB	810-870	170		AL120-798				22.51
93810000AB	AL-BBIT72 AB	910-970	175		AL120-898				25.56
93910000AB	AL-BBIT72 AB	1010-1070	180		AL120-998				28.72
93320000AB	AL-BBIT72 AB	450-510	150		AL120-398				12.12
93420000AB	AL-BBIT72 AB	550-610	155		AL120-498				14.52
93520000AB	AL-BBIT72 AB	650-710	160		AL120-598				17.03
93620000AB	AL-BBIT72 AB	750-810	165		AL120-698				19.53
93720000AB	AL-BBIT72 AB	850-910	170		AL120-798				22.63
93820000AB	AL-BBIT72 AB	950-1010	175		AL120-898				25.68
93920000AB	AL-BBIT72 AB	1050-1110	180	AL120-998	28.84				

AL-BBOR72

大孔徑微調精搪孔刀組合系統

Large Diameter Finishing Cutter Fine Boring System

搪孔刀柄、接盤、鋁製滑座、大孔徑精搪孔刀本體、平衡座、精搪孔刀座
 Taper Shank, Adapter, Aluminium Plate, Large Diameter Body, Balance Holder and Cutting Insert Holder

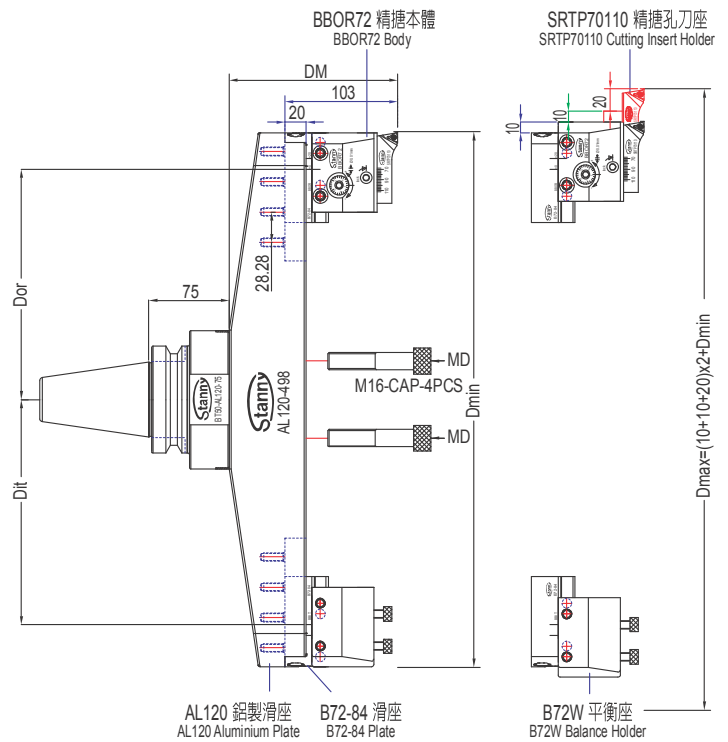

訂貨編號 Order No.	規格 Model	範圍 D Boring Range øDMin-øDMax	深度 DM	大孔徑精搪孔系統組合 Large Diameter Finishing Cutter Fine Boring System					淨重 N.W.
				搪孔刀柄 Taper Shank	鋁製滑座 Aluminium Plate	滑座 Plate	大孔徑精搪孔本體 Boring Head	精搪孔刀座 Cutting Insert Holder	
95310000	AL-BBOR72 M	400-480	150		AL120-398				12.36
95410000	AL-BBOR72 M	500-580	155		AL120-498				14.76
95510000	AL-BBOR72 M	600-680	160		AL120-598				17.27
95610000	AL-BBOR72 M	700-780	165		AL120-698				19.77
95710000	AL-BBOR72 M	800-880	170		AL120-798				22.87
95810000	AL-BBOR72 M	900-980	175		AL120-898				25.92
95910000	AL-BBOR72 M	1000-1080	180	DBT50-H100 (P.19) +	AL120-998				29.08
95320000	AL-BBOR72 M	440-520	150	h100-AL120 (P.103)	AL120-398	B72-84	BBOR72 B72W	SRTP70110	12.47
95420000	AL-BBOR72 M	540-620	155		AL120-498				14.87
95520000	AL-BBOR72 M	640-720	160	BT50-AL120 (P.108)	AL120-598				17.38
95620000	AL-BBOR72 M	740-820	165		AL120-698			SRTP110150	19.88
95720000	AL-BBOR72 M	840-920	170		AL120-798				22.98
95820000	AL-BBOR72 M	940-1020	175		AL120-898				26.03
95920000	AL-BBOR72 M	1040-1120	180		AL120-998				29.19

h100-AL120

搪孔刀柄 Taper Shank for Boring System

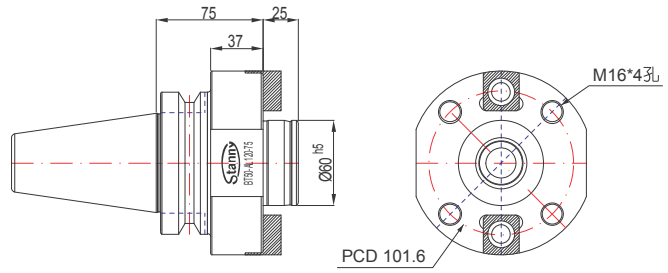

訂貨編號 Order No.	規格 Model	淨重 N.W.
41201507	BT50-AL120-75	7.00

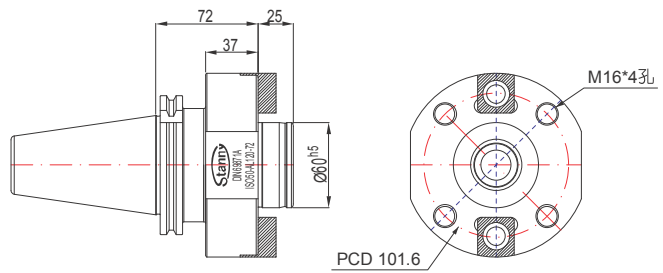

訂貨編號 Order No.	規格 Model	淨重 N.W.
41202507	DIN69871A SK50-AL120-72	7.10

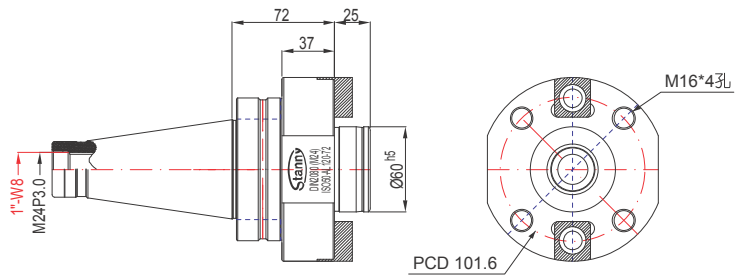

訂貨編號 Order No.	規格 Model	淨重 N.W.
41200507 M	DIN2080 NT50-AL120-72 M24	7.15
41200507 I	DIN2080 NT50-AL120-72 1\"/>	