



我就是鐵牛 I am OX.

CNC立橫銑床

VERTICAL/ HORIZONTAL CNC MILLING MACHINE

適合夾治具、模具、開發件、少量多樣型加工，追加分度盤可做多面體之加工。
Suitable for machining jigs, fixtures, molds and under-development pieces on a small-volume but variety basis and installing rotary table processing on polyhedral work-pieces



千誠機械股份有限公司
CHIEN CHENS MACHINERY CO., LTD.



台灣桃園市中壢區福星六街60之2號
No. 60-2, Fu Hsing 6th St., Chung Li Dist.,
Tao Yuan City, Taiwan
Tel: 886-3-462-6421 Fax: 886-3-462-7645
E-mail: chienchens@hotmail.com.tw
http://www.chienchens.com.tw

台中廠地址：
台中市石岡區豐勢路山下巷28-1號
No.28-1, Shanxia Ln., Fengshi Rd.,
Shigang Dist., Taichung City, Taiwan



千誠機械股份有限公司
CHIEN CHENS MACHINERY CO., LTD.

www.chienchens.com.tw

NT50#(BT) — 齒輪頭傳動結構

Gear Head Transmission Structure



Z 軸滾珠導桿傳動(無手動把手)
Z-axis Ball Screw Transmission
(without manual handle)

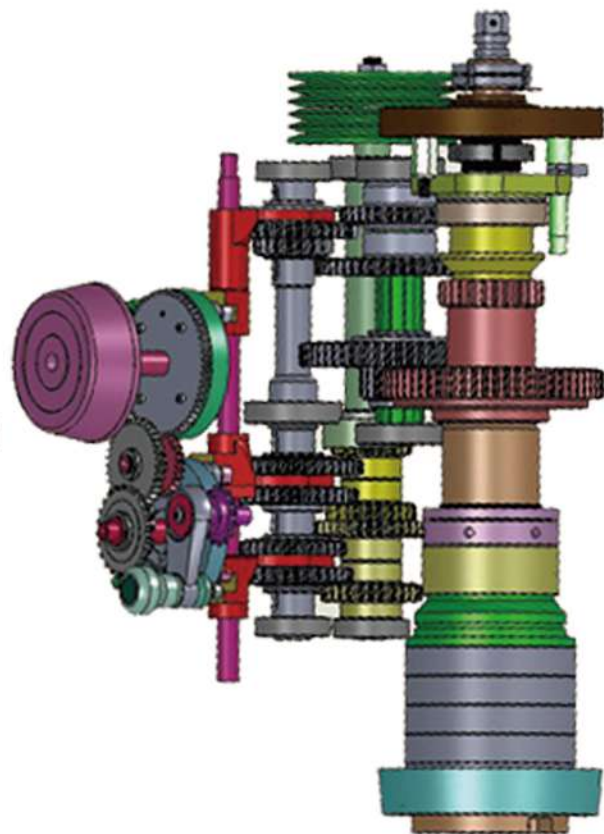

兩軌/四軌底座

Dual / Four-guideway Base

兩軌底座

Dual-guideway Base



X行程1300mm用
for X travel 1300mm



X行程1500mm用
for X travel 1500mm

四軌底座

Four-guideways Base

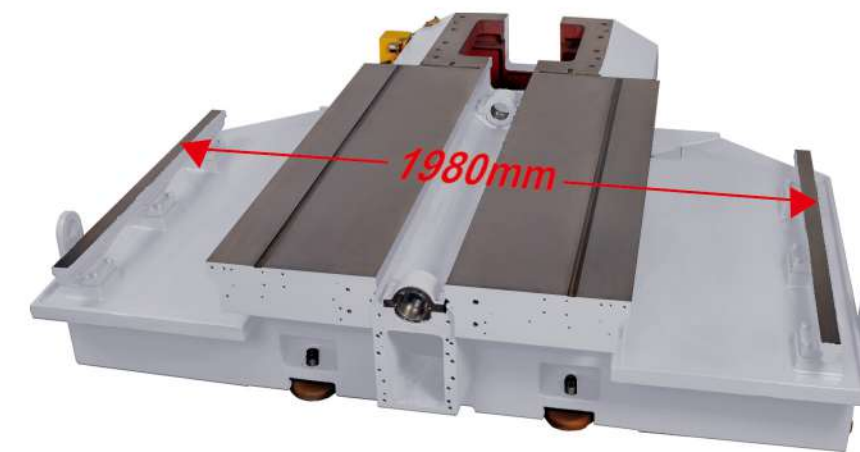

X行程2400mm用
for X travel 2400mm

老師傅的最愛-教導功能

Instruction-typed Function

CNC + 教導功能 + 傳統 = 3用

CNC + Instruction + Tradition = Tri - Use

四軸CNC控制

Four-axis CNC Control



功能：

- 一般G/M碼操作
- 背景編輯
- 巨集程式功能
- 程式傳輸加工功能
- 多國語言
- 圖形模擬顯示
- 硬體自我診斷顯示
- MPG執行加工程式

Function:

- General G/M Code Operation
- Background Editing
- Program Function
- Program Transmission Function
- Multi-national Languages
- Pattern Simulated Display
- Hardware Self-diagnosis Display
- MPG Execute Program

教導功能 Instruction

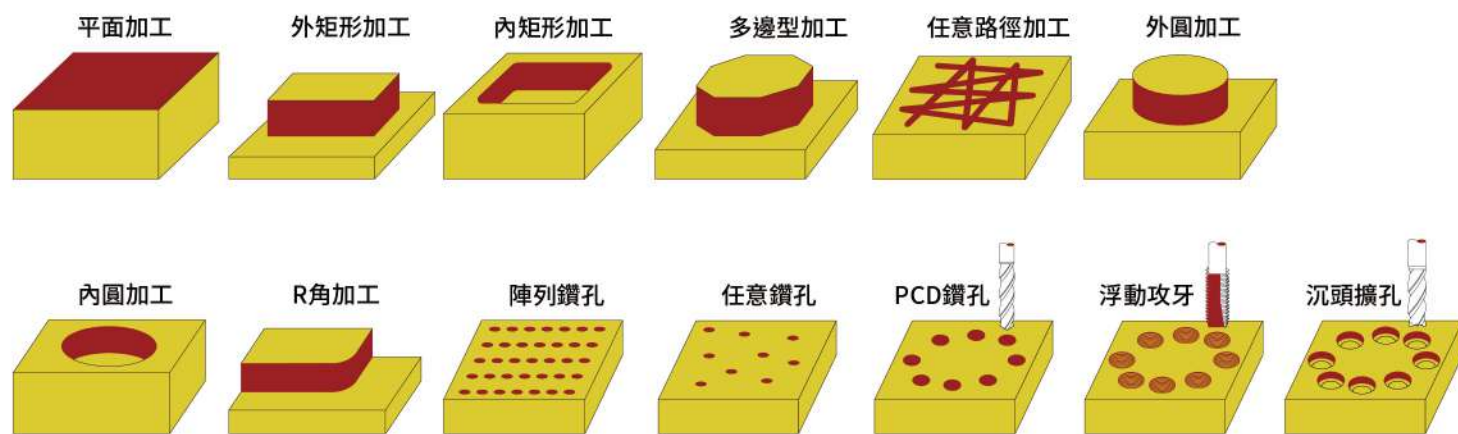

臥式切削機構 Horizontal Type Machining Structure



H臥式切削機構(選配)

H Horizontal Type Machining Structure
(Optional Equipment)

臥式主軸規格BT. NT50# Horizontal Type Milling Head Specifications (BT. NT50#)
主馬達7.5HP / 4P (60HZ) Spindle motor 7.5HP / 4P (60HZ)
上下行程570mm Vertical travel 570mm
滾珠螺桿 Ø32mm P=8mm C3 級 Ballscrews Ø32mm P=8mm single nut with C3 class
減速機無段伺服傳動移動速率10~1200 mm/min Reducer non-step servo transmission Moving speed 10~1200mm/min
主軸轉速：62~1100rpm 6段變速 Spindle Speed 62~1100rpm (6-Step speed)

潤滑油回收盤 (僅限OX-5,OX-6) Lubrication Oil Recycling Tray (Only OX-5,OX-6)



HK臥式砲塔型切削機構(選配), 含攻、鑽、搪、銑等功能 HK Horizontal Turret Type Machining Structure (Optional) tapping, drilling, boring, and milling are available.



臥式主軸規格：BT. NT40# (50#) Horizontal Type Milling Head Specifications BT. NT40# (50#)
主馬達5HP / 4P (60HZ) Spindle motor 5HP / 4P (60HZ)
主軸自動押送，每轉一圈0.035/0.07/0.14mm。 Automatic spindle feeding feature, with each round standing at 0.035/0.07/0.14mm.
上下行程370mm (570mm) Vertical travel 370mm (570mm)
滾珠螺桿 Ø32mm P=8mm C3級 Ballscrews Ø32mm P=8mm single nut with C3 class
減速機無段伺服傳動移動速率10-1200 mm/min Reducer non-step servo transmission Moving speed 10-1200mm/min
主軸轉速：低速57-432rpm，高速424-3600rpm，變頻無段。 Spindle Speed: Low speed: 57~432rpm high speed: 424~3600rpm. Frequency conversion and step-less.
砲管伸縮行程140mm Turret travel: 140mm

Z 軸齒排傳動

Z-axis Gear Transmission

保留傳統操作功能-人性化、
輕巧、靈活、精準、MPG手輪

Reserves traditional operation
functions.

Easy, smart, and precision
MPG hand wheel.

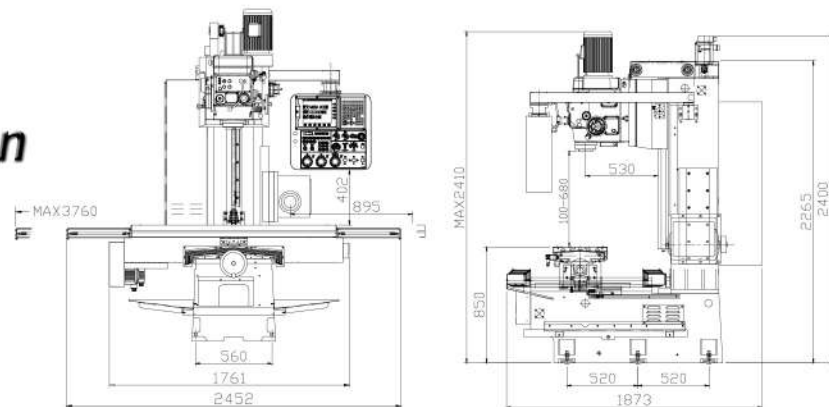

OX-2H

規格 Specification

工作台尺寸 Table size: 1500 x 400 mm

左右行程 Longitudinal travel: 1300 mm

前後行程 Cross travel: 500 mm

Y 軸軌道寬 Y slide way width: 620 mm

Z 軸高 Slide high: MAX 700 mm

Z 軸軌道寬 Slide way width: 420 mm

滾珠螺桿 Ballscrew: Ø32 mm P=5 C3 級

主軸斜度 Spindle taper: NT#40(BT)

主軸馬達 Spindle motor: 5HP / 4P

主軸轉速 Spindle speed: 70~3540 RPM

快速進給速率 Feeding speed: 10~6000 mm/min

橫主軸5HP齒輪6速: Hori. Spindle:57~1227 RPM
(A軸梯形牙 A axis acme screw)

淨重 Net weight: 3500 kgs

四軸CNC控制

Four-axis CNC Control

老師傅的最愛-教導功能

Instruction-typed Function

CNC+教導功能+傳統=3用
CNC + Instruction + Tradition = Tri - Use

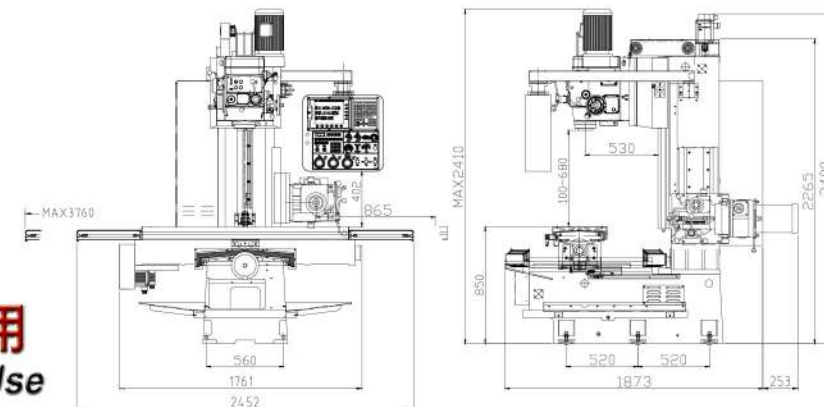

OX-2BHK

規格 Specification

工作台尺寸 Table size: 1500 x 400 mm

左右行程 Longitudinal travel: 1300 mm

前後行程 Cross travel: 500 mm

Y 軸軌道寬 Y slide way width: 620 mm

Z 軸高 Slide high: MAX 700 mm

Z 軸軌道寬 Slide way width: 420 mm

滾珠螺桿 Ballscrew: Ø32 mm P=5 C3 級

主軸斜度 Spindle taper: NT#40(BT)

主軸馬達 Spindle motor: 5HP / 4P

主軸轉速 Spindle speed: 70~3540 RPM

快速進給速率 Feeding speed: 10~6000 mm/min

橫主軸5HP變頻無段: Hori. Spindle:57~3600 RPM
(A軸梯形牙 A axis acme screw)

淨重 Net weight: 3500 kgs

四軸CNC控制 Four-axis CNC Control

老師傅的最愛-教導功能
Instruction-typed Function

CNC+教導功能+傳統=3用
CNC + Instruction + Tradition = Tri - Use

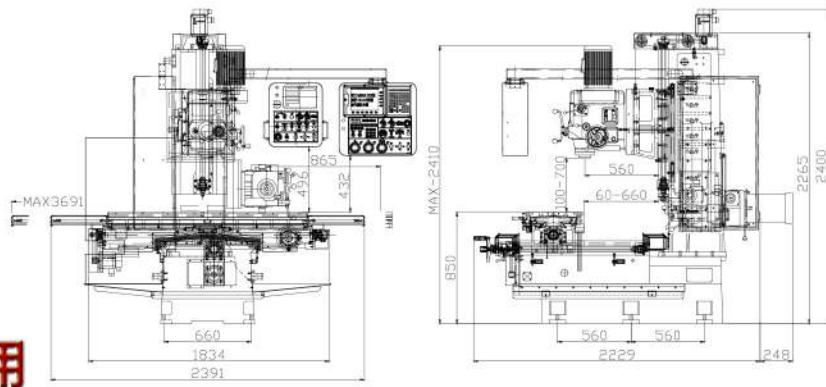

Z: MAX. 700mm
A: 370mm Y: 600mm
X: 1300mm



規格 Specification

工作台尺寸 Table size: 1515 x 470 mm
左右行程 Longitudinal travel: 1300 mm
前後行程 Cross travel: 600 mm
Y 軸軌道寬 Y slide way width: 720 mm
Z 軸高 Slide high: MAX 700 mm
Z 軸軌道寬 Slide way width: 420 mm
滾珠螺桿 Ballscrew: Ø32 mm C3 級

主軸斜度 Spindle taper: NT#40(BT)
主軸馬達 Spindle motor: 5HP / 4P
主軸轉速 Spindle speed: 70~3600 RPM
快速進給速率 Feeding speed: 10~6000 mm/min
橫主軸5HP變頻無段Hori. Spindle: 75~3600 RPM
(A軸梯形牙 A axis acme screw)
淨重 Net weight: 3500 kgs

OX-3BHK

四軸CNC控制 Four-axis CNC Control

老師傅的最愛-教導功能
Instruction-typed Function

CNC+教導功能+傳統=3用
CNC + Instruction + Tradition = Tri - Use

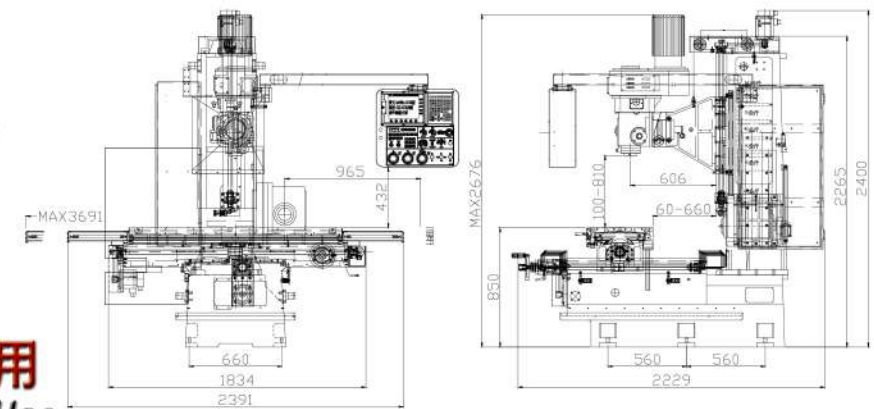

Z: MAX. 810mm
A: 370mm Y: 600mm
X: 1300mm



規格 Specification

工作台尺寸 Table size: 1515 x 470 mm
左右行程 Longitudinal travel: 1300 mm
前後行程 Cross travel: 600 mm
Y 軸軌道寬 Y slide way width: 720 mm
Z 軸高 Slide high: MAX 810 mm
Z 軸軌道寬 Slide way width: 420 mm
滾珠螺桿 Ballscrew: Ø32 mm C3 級

主軸斜度 Spindle taper: NT#40(BT)
主軸馬達 Spindle motor: 5HP / 4P
主軸轉速 Spindle speed: 75~3600 RPM
立主軸砲管伸縮行程 Spindle Barrel Telescopic Travel: 140 mm/min
主軸簡易攻牙裝置 Spindle Simple Tapping Device
橫主軸齒輪6速5HP變頻無段 Hori. Spindle 6 Gear: 57~1227 RPM
(A軸梯形牙 A axis acme screw)
淨重 Net weight: 3500 kgs

OX-3BTH

Z 軸齒排傳動

Z-axis Gear Transmission

保留傳統操作功能-人性化、
輕巧、靈活、精準、MPG手輪

Reserves traditional operation
functions.

Easy, smart, and precision
MPG hand wheel.

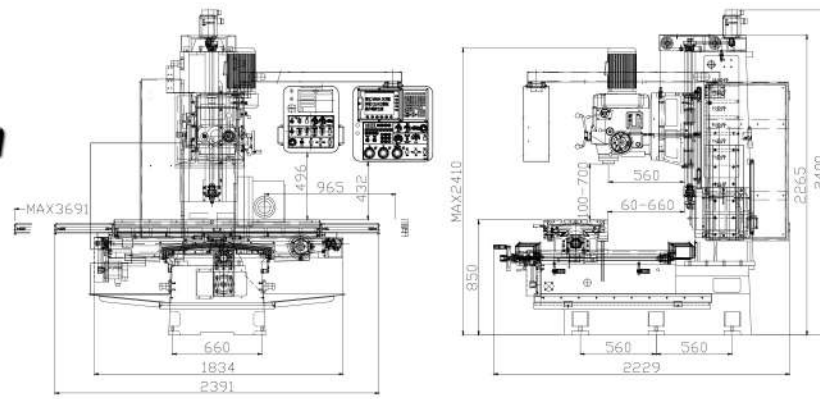

OX-3

規格 Specification

工作台尺寸 Table size: 1515 x 470 mm
左右行程 Longitudinal travel: 1300 mm
前後行程 Cross travel: 600 mm
Y 軸軌道寬 Y slide way width: 720 mm
Z 軸高 Slide high: MAX 700 mm
Z 軸軌道寬 Slide way width: 420 mm

主軸斜度 Spindle taper: NT#40(BT)
主軸馬達 Spindle motor: 5HP / 4P
主軸轉速 Spindle speed: 70~3600 RPM
快速進給速率 Feeding speed: 10~6000 mm/min
滾珠螺桿 Ballscrew: Ø32 mm C7 級
淨重 Net weight: 3200 kgs

三軸CNC控制 Three-axis CNC Control

老師傅的最愛-教導功能
Instruction-typed Function

CNC+教導功能+傳統=3用
CNC + Instruction + Tradition = Tri - Use

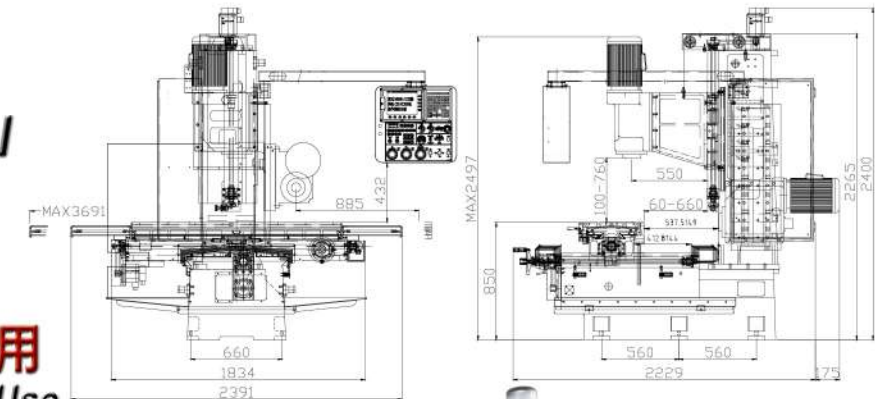

OX-3BG-50

規格 Specification

工作台尺寸 Table size: 1515 x 470 mm
左右行程 Longitudinal travel: 1300 mm
前後行程 Cross travel: 600 mm
Y 軸軌道寬 Y slide way width: 720 mm
Z 軸高 Slide high: MAX 760 mm
Z 軸軌道寬 Slide way width: 420 mm

主軸斜度 Spindle taper: NT#50(BT)
主軸馬達 Spindle motor: 7.5HP / 4P
主軸轉速 Spindle speed: 62~1100 RPM
快速進給速率 Feeding speed: 10~6000 mm/min
滾珠螺桿 Ballscrew: Ø32 mm C3 級
淨重 Net weight: 3200 kgs

Z 軸齒排傳動

Z-axis Gear Transmission

保留傳統操作功能-人性化、
輕巧、靈活、精準、MPG手輪

Reserves traditional operation
functions.

Easy, smart, and precision
MPG hand wheel.

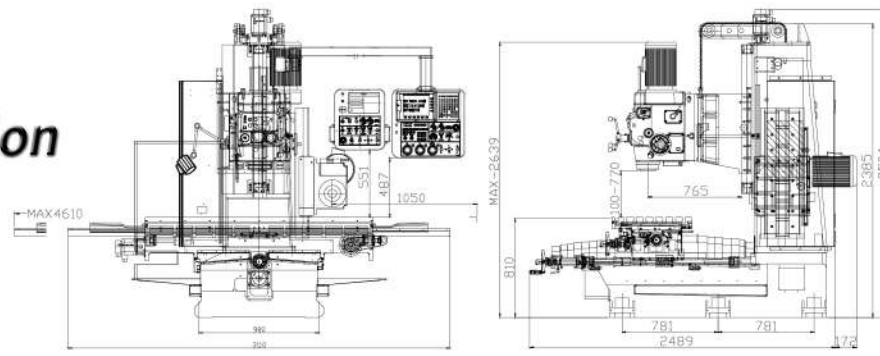

OX-5-50H

規格 Specification

工作台尺寸 Table size: 1850 x 650 mm
左右行程 Longitudinal travel: 1500 mm
前後行程 Cross travel: 800 mm
Y 軸軌道寬 Y slide way width: 1000 mm
Z 軸高 Slide high: MAX 800 mm
Z 軸軌道寬 Slide way width: 500 mm
滾珠螺桿 Ballscrew: Ø40 mm P=8 C3 級

主軸斜度 Spindle taper: NT#50(BT)
主軸馬達 Spindle motor: 7.5HP / 4P
主軸轉速 Spindle speed: 40~3000 RPM
快速進給速率 Feeding speed: 10~6000 mm/min
橫主軸齒輪6速7.5HP變頻無段
Hori. Spindle 6 Gear 7.5HP :62~1100 RPM
淨重 Net weight: 5500 kgs

四軸CNC控制

Four-axis CNC Control

老師傅的最愛-教導功能
Instruction-typed Function

CNC+教導功能+傳統=3用
CNC + Instruction + Tradition = Tri - Use

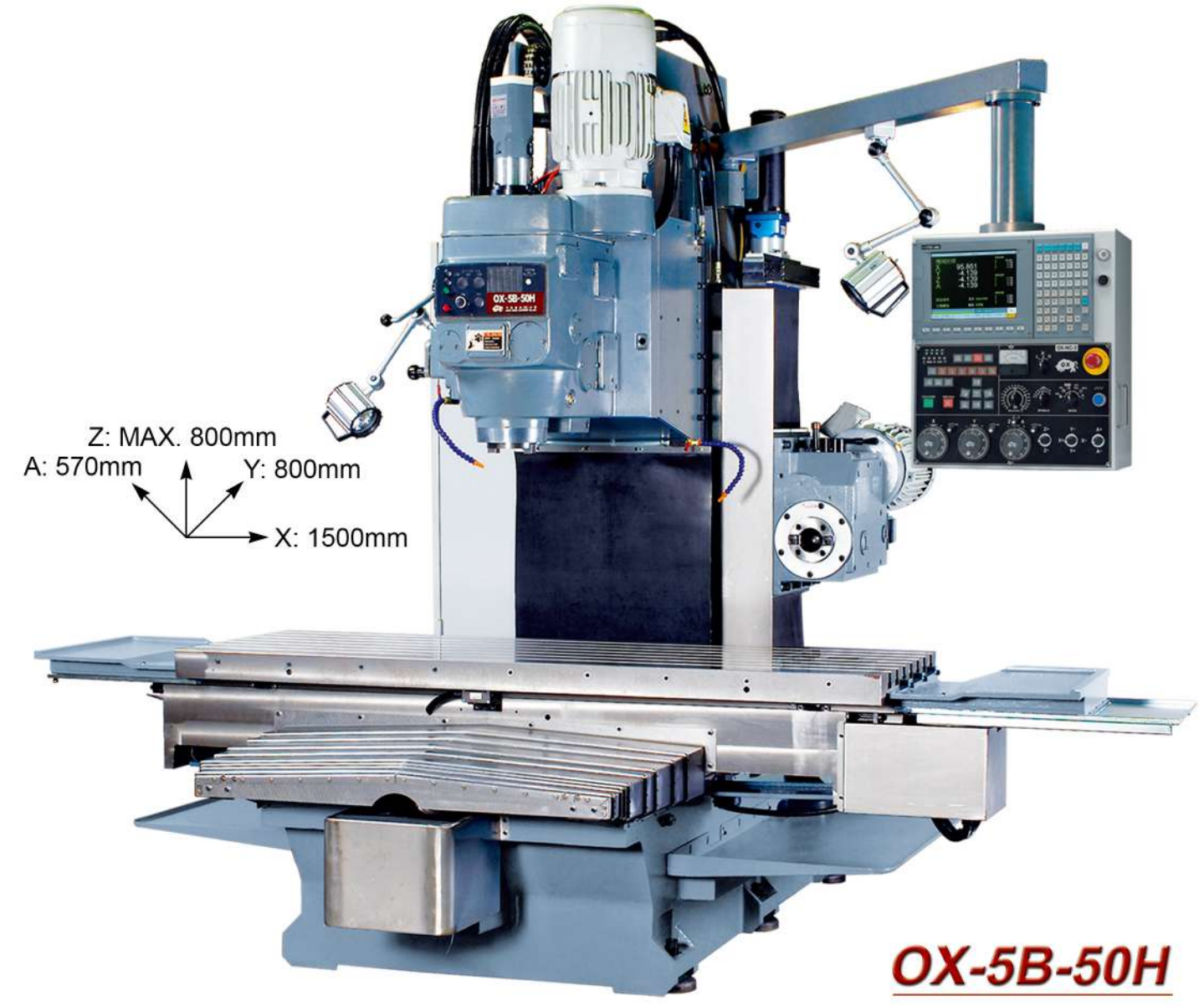
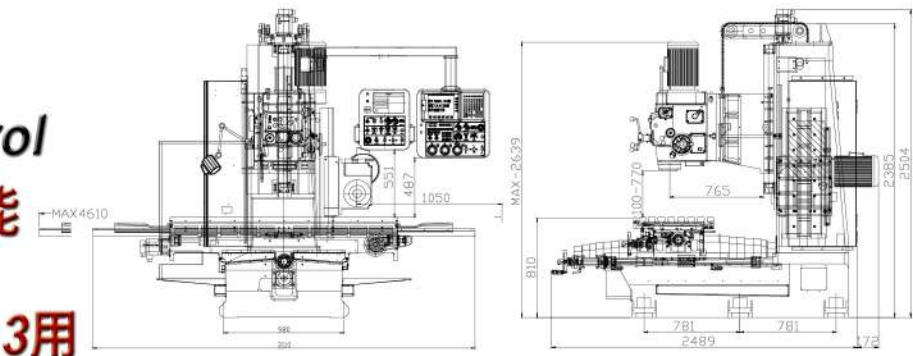

OX-5B-50H

規格 Specification

工作台尺寸 Table size: 1850 x 650 mm
左右行程 Longitudinal travel: 1500 mm
前後行程 Cross travel: 800 mm
Y 軸軌道寬 Y slide way width: 1000 mm
Z 軸高 Slide high: MAX 800 mm
Z 軸軌道寬 Slide way width: 500 mm
滾珠螺桿 Ballscrew: Ø40 mm P=8 C3 級

主軸斜度 Spindle taper: NT#50(BT)
主軸馬達 Spindle motor: 7.5HP / 4P
主軸轉速 Spindle speed: 40~3000 RPM
快速進給速率 Feeding speed: 10~6000 mm/min
橫主軸齒輪6速7.5HP變頻無段
Hori. Spindle 6 Gear 7.5HP :62~1100 RPM
淨重 Net weight: 5500 kgs

三軸滾珠螺桿

Three-axis Ballscrew

保留傳統操作功能-人性化、輕巧、靈活、精準、MPG手輪

Reserves traditional operation functions.

Easy, smart, and precision MPG hand wheel.

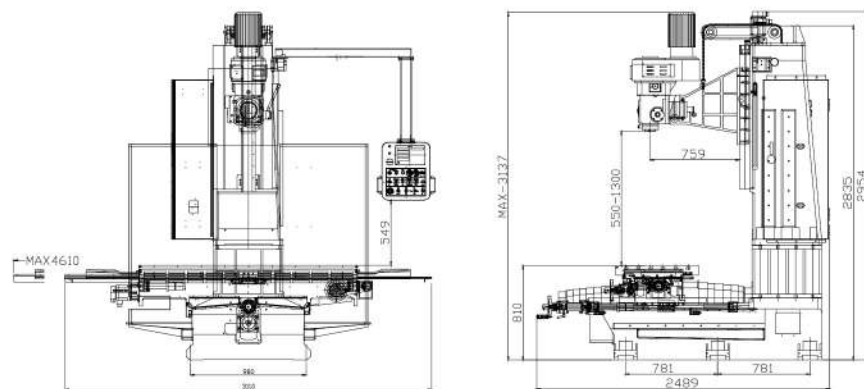

Z: MAX. 1300mm(550~1300mm)
Y: 800mm
X: 1500mm



OX-5BT(加高型)

規格

Specification

工作台尺寸 Table size: 1850 x 650 mm

左右行程 Longitudinal travel: 1500 mm

前後行程 Cross travel: 800 mm

Y 軸軌道寬 Y slide way width: 1000 mm

Z 軸高 Slide high: MAX 1300 mm (550~1300mm)

Z 軸軌道寬 Slide way width: 500 mm

主軸斜度 Spindle taper: NT#40(BT)

主軸馬達 Spindle motor: 5HP / 4P

主軸轉速 Spindle speed: 75~3600 RPM

快速進給速率 Feeding speed: 10~6000 mm/min

滾珠螺桿 Ballscrew: Ø40 mm P=8 C3 級

淨重 Net weight: 5200 kgs

四軸CNC控制 Four-axis CNC Control

老師傅的最愛-教導功能
Instruction-typed Function

CNC+教導功能+傳統=3用
CNC + Instruction + Tradition = Tri - Use

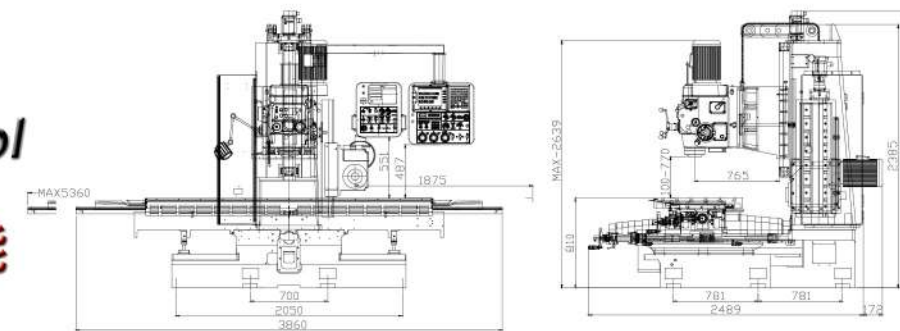

Z: MAX. 800mm
A: 570mm
Y: 800mm
X: 2400mm



OX-6B-50H

規格

Specification

工作台尺寸 Table size: 2600 x 650 mm

左右行程 Longitudinal travel: 2400 mm

前後行程 Cross travel: 800 mm

Y 軸軌道寬 Y slide way width: 1000 mm

Z 軸高 Slide high: MAX 800 mm

Z 軸軌道寬 Slide way width: 500 mm

主軸斜度 Spindle taper: NT#50(BT)

主軸馬達 Spindle motor: 7.5HP / 4P

主軸轉速 Spindle speed: 40~3000 RPM

快速進給速率 Feeding speed: 10~6000 mm/min

滾珠螺桿 Ballscrew: Ø40 mm P=8 C3 級

淨重 Net weight: 6800 kgs