

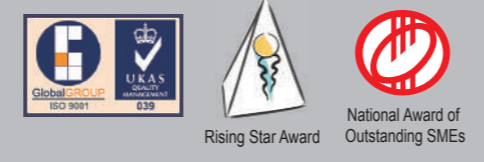

ACCUTEX TECHNOLOGIES CO., LTD.

No. 20, Jingke Rd., Nantun District, Taichung City 40852, Taiwan.
 TEL : +886-4-2359-9688 FAX : +886-4-2359-7266
 e-mail: sales@accutex.com.tw http:// www.accutex.com.tw
 e-mail: service@accutex.com.tw



Environmental Requirements

Power source	AC220V/AC380V±5% : 3Phase 50 / 60Hz±1Hz
Temperature /Humidity	25±1°C : less than 75%RH
Environment	<ul style="list-style-type: none"> The machine should be not placed near punching machine, drilling machine or any interfering sources. The machine should be not placed near heat treatment or electroplate systems. The machine should be placed in an airtight room to keep dust out. Before positioning machine, pay attention to machine movement during operation and the space needed for maintenance. Solid foundation of horizontal error should be less than 20µm.
Earth construction	Earth resistance below 10Ω : separate the earth terminal with other machines.
Pneumatic pressure	≥ 6kg / cm ² (Applicable for machine with AWT and linear motor)

■ Due to continual research and development, specifications are subject to change without notice.

Cat. 2017.10-1000 © L.Y.S

AL series

The Best Solution in
CNC Wire Cut EDM Technology

Linear Motor Built-in



AL SERIES

Shaft Linear Motor

- Shaft Linear motor driven with full closed loop control without backlash can use for a long time with high repeatability, low friction loss and high efficiency.
- Rapid servo response can enhance the sensitivity of discharge gap control for the cutting speed up 8%~10%

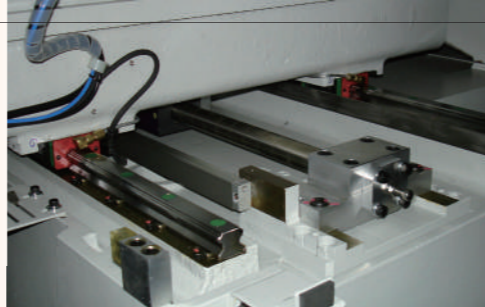

Linear Motor



Improving Cutting Performance

Rapid servo response prevents wire breaking and increases cutting speed.

Shaft Linear Motor
lower maintenance cost

Flat Type Linear Motor

Rotary Motor

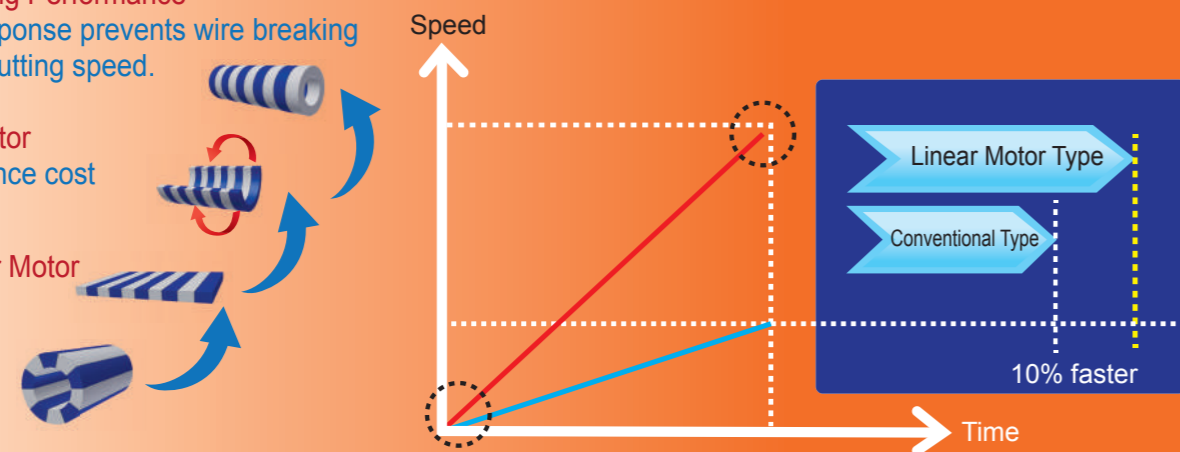

Corner Control (Corner Pro)

According to different cutting data, wire diameter, angle and workpiece thickness, the Accutex controller automatically optimizes parameters to maintain the best corner cutting performance with high accuracy, as well as cutting speed. Even on the small and continuous corners, Accutex still can meet the best corner accuracy.

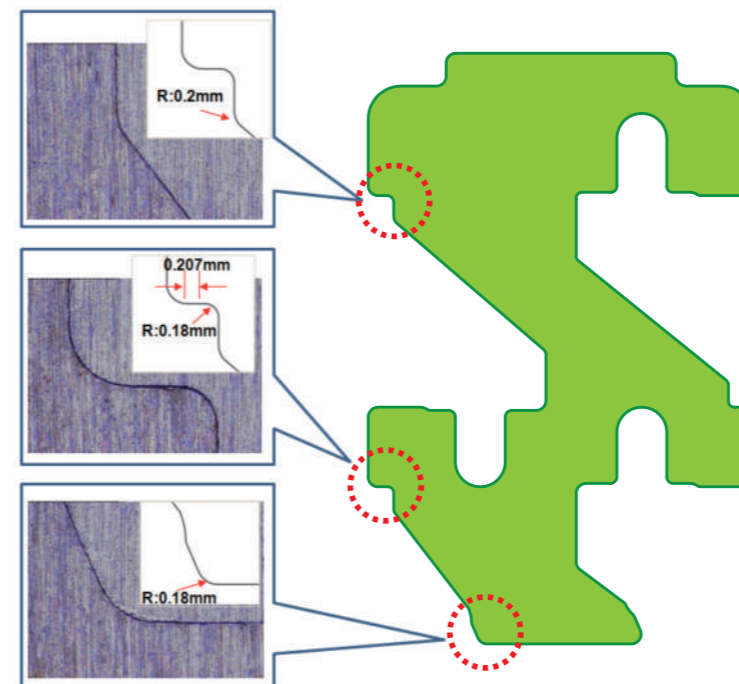

Cutting Speed :

1st Cut : 130 mm²/min Wire : Ø0.25mm
2nd Cut : 260 mm²/min Thickness : 50mm
3rd Cut : 320 mm²/min

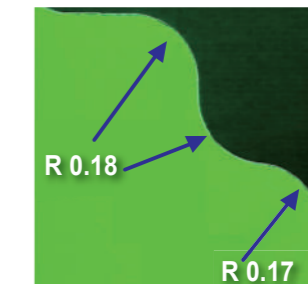

Contour matches closely between workpiece and cutting path.

Punch and die can match smoothly within 3µm clearance.



Corner, Arc and Lead In/Out Controls can be enabled / disabled directly from setting or by M-code.

High Resolution Signal Processor

High resolution signal processor achieves more smooth velocity control, and enhances the stability of position control. It can match up the best contouring accuracy. The best resolution for standard scale can narrow down to 20nm.

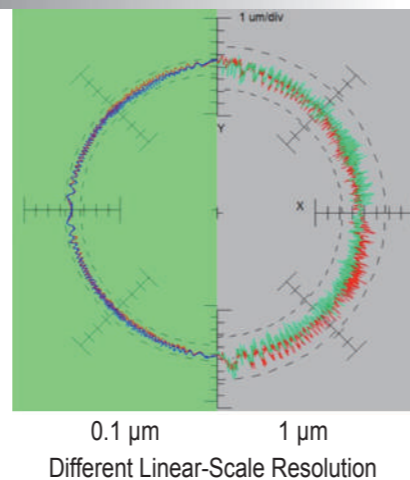
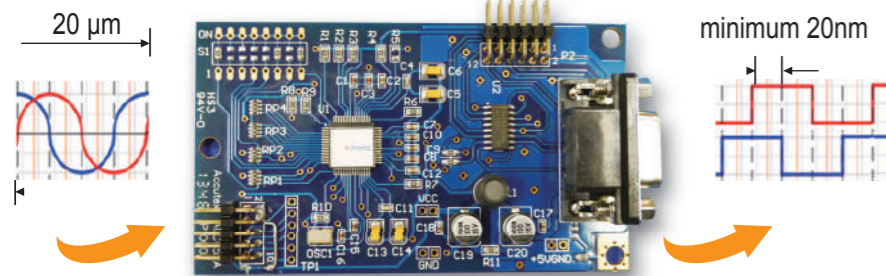

Auto Taper Angle for Wire Consumption

Users just input workpiece material/wire diameter/thickness to get taper angle for cutting and it is very easy to bring taper angle command to the cutting program. Users do not need to write command in the program by themselves. This helps to reduce difficulty and time cost.

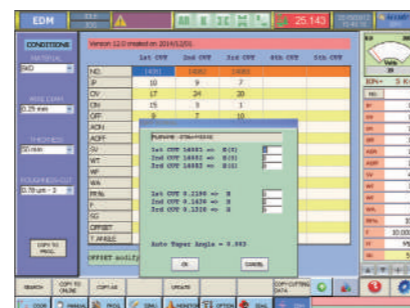
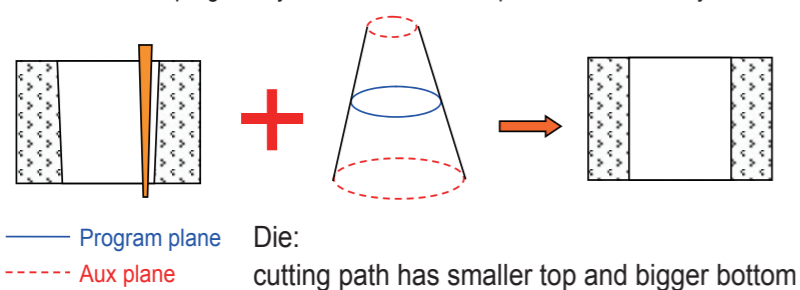

Lead in/out Technology

Reduce the wire mark at lead-in block less than 2µm.

Material: SKD11
Wire : 0.25mm
Thickness : 50mm
Cutting times: 3

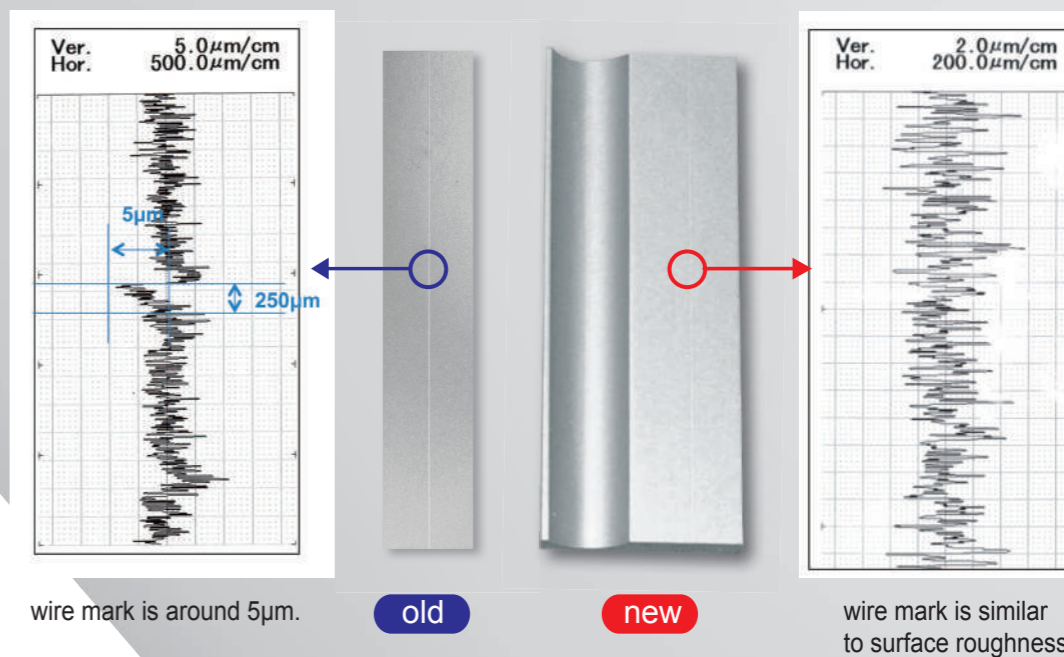

Stable Discharge Board (SD-Master)

- High repeatability in accuracy by applying the same cutting data on different machines, the consistence enhances the quality of workpiece and simplifies management procedure.
- High speed cutting by SD-Master in stable discharge power stabilizes the cutting process, especially under high-speed mode.
- By Cutting 100 holes of 6mm continuously, 95.45% of all workpieces accuracy are within $\pm 1.5\mu\text{m}$. Cutting conditions are made by SKD-11 with 30mm thickness by 0.25mm brass wire with 3 cuts under good temperature and environment control.

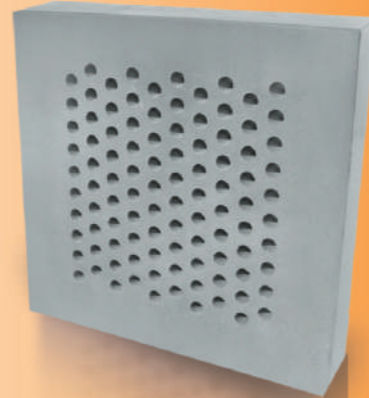
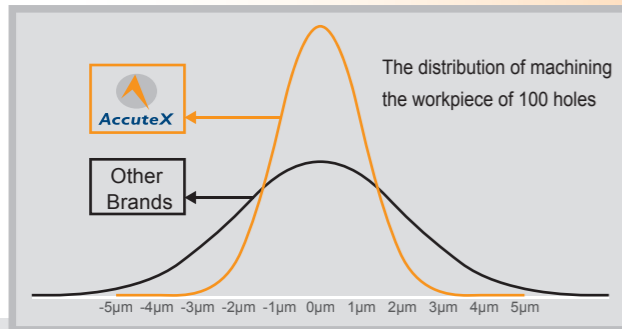

Irregular Thickness Cutting

The AccuteX intelligent discharge unit is capable of dealing with the changing conditions in workpiece thickness and water flushing situations, featuring high cutting speed, and free from wire breaking problems.

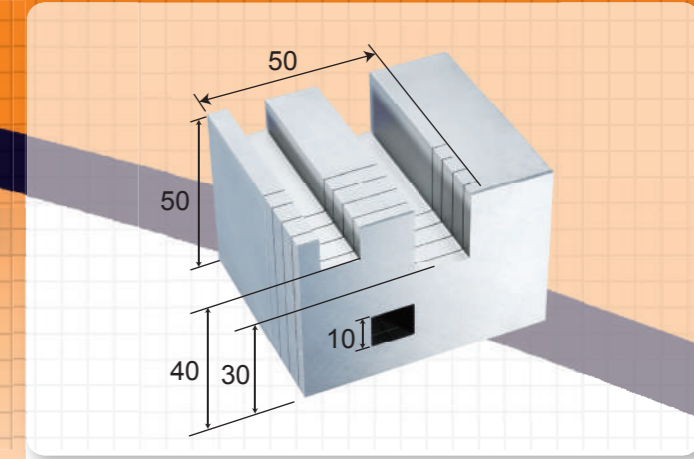

With a single workpiece of different thickness, the maximum cutting speed can be 3.3 mm per minute.

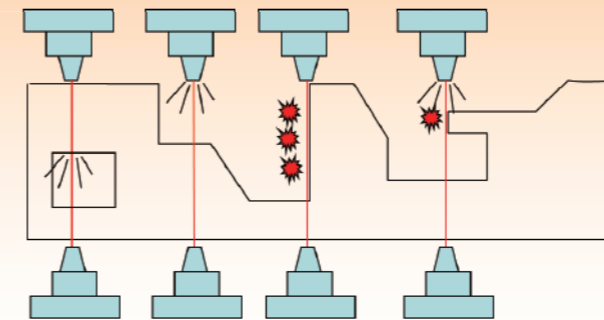

Efficiency Increased up to 34%

Irregular Thickness Cutting Time:

New : 15 min.
Old : 23 min.

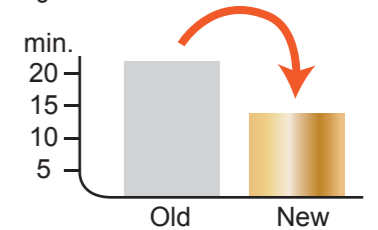

MST

- Micro Sparking Technology(MST), this unique technology can reach the best surface roughness to Ra.0.08 μm (*)

(*) Optional

Cuts	Ra
1 Cut	Ra 2.67 μm
2 Cuts	Ra 2.20 μm
3 Cuts	Ra 0.67 μm
4 Cuts	Ra 0.38 μm
5 Cuts	Ra 0.26 μm
6 Cuts	Ra 0.20 μm
7 Cuts	Ra 0.15 μm
8 Cuts	Ra 0.11 μm
9 Cuts	Ra 0.08 μm

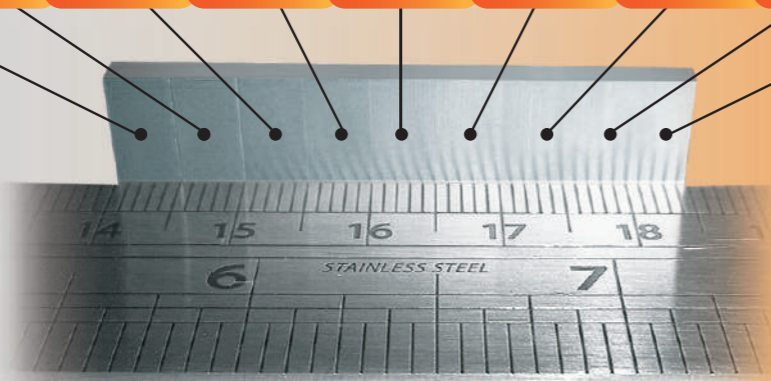

(*)The cutting condition and other related settings are based on AccuteX service information.

Cutting Efficiency Comparison

- AccuteX R&D team simplifies the generator and electric circuit to eliminate unnecessary power loss, and enhance the cutting efficiency.
- The cutting efficiency compared with other brands under different workpieces thickness is as below.

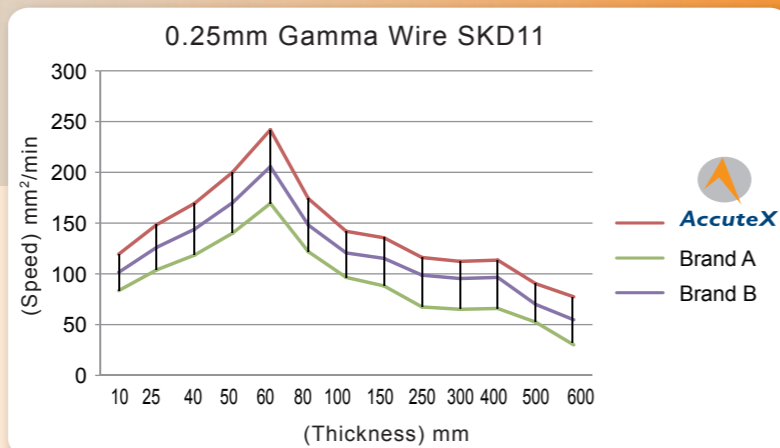

(*) Date from Accutex service database

AWT, Best Threading Reliability (*)

AC servo tension wheel

- "AC Servo Tension Wheel", tension control during cutting, features reverse tension while wire breaks.
- "Wire End Needle-Shaping", while the wire is cut off by electricity, the reverse tension and annealing heat treatment are applied to strengthening the wire at the same time.
- "Waste Wire Auto Removing Device" is Accutex exclusive device, used by air blow system to remove waste wire to the collection cabinet quickly and easily.



Accutex Wire End Needle-shaping

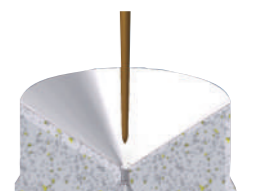

(*) Optional

AccuteX Submerged Type Rotary Table (*)

- Accutex 6th Axis Rotary Table is leading ahead of other WEDM manufacturers by years in R&D which can be applied to submerged operation.
- The Built-in Type Motorized Spindle features ultra-high resolution 720,000 pulses per each revolution, free of backlash problems.
- With IP68 waterproof class, the Accutex Rotary Table may totally be submerged in the water and will still maintain high performance and high accuracy.
- Rotary table can be applied in the vertical and horizontal types.

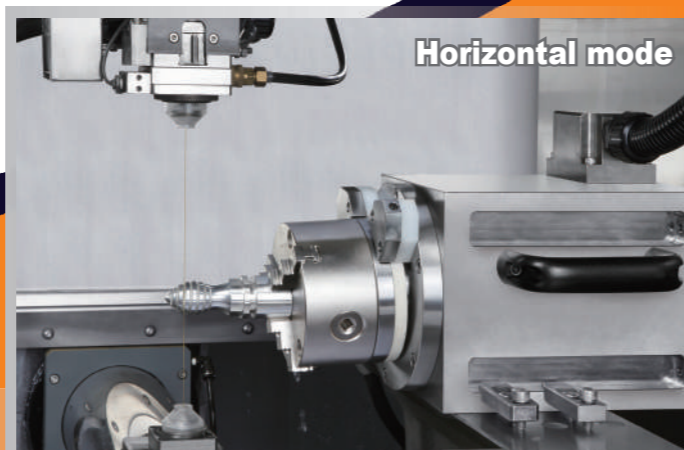

(*) Optional

Synchronously cutting



Medical part



Precise robotics component



Array electrode

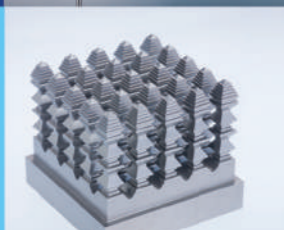

PCD Cutting & Graphite Machining Power Supply (*)

- The exclusive ignition circuit and stabilized discharging power supply are the most suitable design for PCD and graphite cutting; furthermore, with quality assurance for a long time machining.
- The collapse of workpiece edge by wire cut can be controlled within minimum range along with high speed machining.
- Accutex wire cut EDM can do 5 axes simultaneous interpolation, also the W axis (6th Axis rotary table) can be installed while doing complex PCD cutting tools.



PCD MODULE

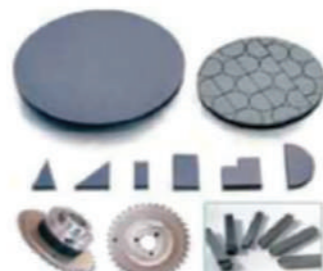

PCD applications



PCD cutting tool

Machine Specifications

Specifications	MODEL				
	Submerged Type				
	AL-400SA	AL-500SA	AL-560SA	AL-600SA	AL-750SA
Max. Workpiece Size L x W x H (mm)	790x610x215	990x610x295	990x610x295	990x650x295	1190x800x295
Max. Workpiece Weight (Kg)	400	500	500	550	750
X/Y Stroke (mm)	400x300	500x300	560x360	600x400	750x500
U/V Stroke (mm)	100x100	100x100	100x100	100x100	100x100
Z Stroke (mm)	220	300	300	300	300
Max. Cutting Taper (H=100)	± 21°	± 21°	± 21°	± 21°	± 21°
Wire Spool Weight (Kg)	10	10	10	10	10
Footprint W x D x H (mm)	2051×2990×2070	2480×2980×2210	2480×2980×2210	2480×2980×2210	3000×3200×2250
Water System Capacity (L)	630	900	900	900	1060
Machine Weight (Kg)	3000	3600	3600	3700	4300

(*)To acquire the optimum stable cutting performance, the suggested-maximum height of cutting workpiece is the Z axis stroke minus 30mm.

Controller Functions

Backlash compensation	Constant / Servo feed	Different shape interpolation	Auto position (edge, center)
Linear / Circular interpolation	Auto power recovery	Background edit	Soft limit
Cutting path display	Trace to break point	Start point return	Corner control function
Retrace to start point	Reference point return	Break point return	Diagnosis
Reference point setting	Taper cutting	Auto corner	Z axis software limit
Multi-blocks skip	Maintenance memo	Program edit / copy / delete	Manual data input
Cutting log	Axis exchange	Rotation	Auto / Manual feed
Mirror	Dry run	Single block	Short back
Optional stop	Block stop	Sub program	Wire consumption offset
Pitch compensation	Parallel compensation	2nd. Soft limit	Anti-Collision

Controller Specifications

Controller System	Windows CE
Control Device	64-bit Industrial PC
Memory Device	≥1GB CF Card
Screen Display Device	17" Color TFT Touch Screen
Data Input	Keyboard, Mouse Pointer, RS-232, USB, Ethernet, FTP
No. of Control Axes	5 Axes / 6 Axes (Option on W Axis)
Simultaneous Axes	4 Axes / 5 Axes (Option on W Axis)
Min. Command Unit	0.0001 mm
Max. Command Range	± 9999.9999 mm
Command Type	mm / inch
Cutting Data Memory	99999 Sets
Ignition Power Supply	32 Steps, 53V~138V
On Time	24 Steps
Off Time	43 Steps
Discharge Mode	Rough Cut / Skim Cut / Fine Cut

Standard Accessories

- Upper / Lower Flushing Nozzle
- Diamond Guide
- Conductor Plate
- Diamond Guide Remove Jig
- Brass Wire
- Tool Box
- Waste Wire Bin
- Ion Resin Tank
- Ion Exchange Resin
- Paper Filter
- Vertical Alignment Jig
- Water Chiller
- SD Master
- Auto Wire Threading (AWT)

Optional Accessories

- Spray mist Lubricator
- Safety Door Interlock
- Transformer
- MST (AL-400SA/500SA/560SA/600SA)
- Pilot Lamp
- PCD / Graphite Cutting
- 45Kg Wire Jumbo Feeder
- High Pressure Water Jet Threading (Anti-Collision on Z-Axis is invalid)
- Remote Master
- 0.1mm Wire Application
- Auto Voltage Stabilizer
- Alarm Messenger
- 6th Axis Package (W axis)