



CUTTING TOOLS

MAROX TOOLS INDUSTRIAL CO., LTD.

明祿出水刀具型錄

OIL HOLE CUTTING TOOLS CATALOG



2023 ▶ 2024

- ▶ External Turning Tools
- ▶ Boring Bars
- ▶ Threading Tools
- ▶ Grooving Holders

公司簡介 About Us

明祿工業股份有限公司成立於1976年。創始之初從事特殊刀具和焊接式銑刀製造，但在隨後的幾年，為了製造全系列的車削和銑削刀具，以解決客戶加工上所遇到的難題，我們不僅擁有訓練有素的技工，還安裝了先進的數控加工中心和精密設備並提供專業服務以滿足顧客需求。

經過不斷的發展和遍布全球的銷售推廣，時至今日明祿已經是成功的金屬切削刀具製造商，並且以每年至少10%的成長率，和65%進出口率感到自豪。目前，我們主要出口市場包括美國、澳洲、日本、韓國、香港、馬來西亞、印尼、英國、義大利、葡萄牙、智利和阿根廷。

2015年更擴大廠房面積設置產品線，嚴格為產品品質把關。

2019年根據ISO13399制定刀具規範，並增加更多的量測設備-Zoller。

Marox Tools Industrial CO., LTD. was established in 1976.

Special cutters and welded milling cutters were produced in the beginning.

In the following years, aiming at producing complete ranges of Milling Tools and Turning Tools, we have not only trained skilled mechanics, but also installed more advanced CNC machine centers, precision facilities together with professional service to fulfill our ambition.

Through continuous development and worldwide sales promotion, we have been a successful metal cutting tool manufacturer and am proud of 10% minimum growth annually and an export rate of 65% in our production. Our current main export markets include the USA, Australia, Japan, Korea, Hong Kong, Malaysia, Indonesia, the UK, Italy, Portugal, Chile and Argentina.

In 2015, we've expanded factory area, production line and strictly test our quality in order to satisfy our customers' demand.

In 2019, we established standardized processes and procedures of cutting tools according to ISO 13399. Inspection and measuring for cutting tools by Zoller.



產品介紹 PRODUCTS

外徑車刀 Turning Tools

內孔車刀 Boring Bars

外徑/內孔牙刀 Threading Tools

切斷槽刀 Grooving Holders

切斷刀板 Blade for Parting-off

套筒 Sleeves

抗震刀桿 Carbide Chuck

端銑刀 End Mills

內徑車刀輔助刀座 Boring Bar Quick Center Block

面銑刀 Face Mills

側銑刀 Side Mills

殼形銑刀 Shell End Mills

鎖牙式銑刀 Modular End Mills

T型銑刀 T-Slot End Mills

倒角刀 Chamfer Milling Cutters

卡式刀座 Cartridges

鑽頭 Indexable Drills

刀片 Inserts



1976

- ◆ 成立明祿工業股份有限公司
Established MAROX Tools Industrial Co., Ltd



1979

- ◆ 生產拋棄式銑刀和車刀，與日本、美國品牌合作製作新刀具並承接OEM訂單
Producing throw-away milling cutters and turning tools for some major brand tools in Japan and U.S.A.

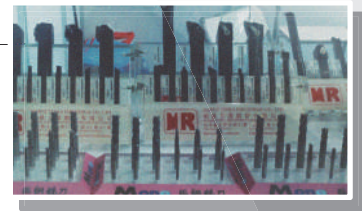

1996

- ◆ 導入ERP系統
Integrating production process by latest ERP implementation.

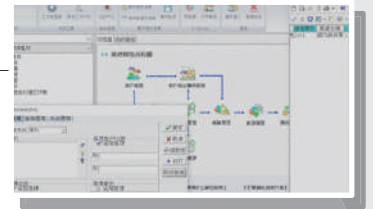

1997

- ◆ 增設專用設備產線和測量儀器
Increased special machines and measuring equipment.

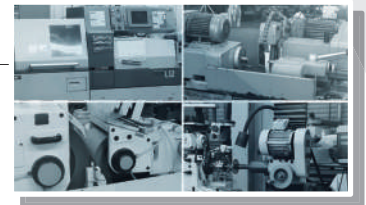

2006

- ◆ 首次參加台北國際工具機展覽
Participated in 2006 TIMTOS

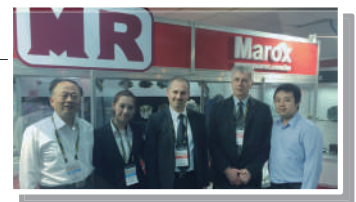

2015

- ◆ 擴大廠房面積增設更多種類刀具產品線
We've expanded factory area, production line and developed various cutting tools for our customers' requirements.



2019

- ◆ 根據ISO13399制定刀具規範，並增加更多的量測設備-Zoller
We established standardized processes and procedures of cutting tools according to ISO 13399. Inspection and measuring for cutting tools by Zoller.



2021

- ◆ 人力倍增，培訓更多專業技術人才
Increase more colleague with technical capability.











INDEX 索引





外徑車刀

Turning Tools		
	AACLN	P1
	AATJN	P1
	AATQN	P2
	AAWLN	P2
	ADCLN	P3
	ADDJN	P3
	ADDQN	P4
	ADTEN	P4
	ADTJN	P5
	ADTQN	P6
	ADVJN	P6
	ADWLN	P7
	AMCLN	P7
	AMDJN	P8
	AMTJN	P8
	AMVJN	P9
	APCLN	P9
	ASCLC	P10
	ASDNC	P10
	ASDJC	P11
	ASTUP	P12

外徑車刀

Turning Tools		
	ASVJB	P12
	ASVJC	P13
	ASVJC-A	P13
	ASVJC-NA	P13
	ASVJP	P14
	ASVKB	P14
	ASVKC	P15
	ATJNR	P15
	AWLNR	P16

內孔車刀

Boring Bar		
	L-SCLC-V	P17
	L-SDUC-V	P17
	L-STLC-V	P18
	L-STUP-V	P18

牙刀

Threading Tools		
	ASER	P19
	ASER-WP	P19
	ASER-NA	P19

槽刀

Grooving Tools		
	ACGWS	P20
	AEVSC/M	P20
	ADGT	P21
	AGHR	P22
	AGNDMR	P23
	AGHSR	P24
	AGWC	P25
	T#R 槽刀片	P25
	AKGD	P26
	ASLAL-38	P27
	L#R 槽刀片	P27
	ATGTR	P28
	ATSE	P28
	ATTE	P29
	AWGCSM	P29
	AUASR/AUSR	P30
	N#R 槽刀片	P30

- Direct coolant supply through the turning tool.
- Shorten processing time by high cutting speed.
- 30 to 150% longer tool life for different kind of materials.
- Improved chip breaking, particularly at pressures above 40 bar.

ADTJNR

D-Type Turning Tools with coolant

出水外徑車刀

ADTJNR零件拆解示意圖-僅供參考

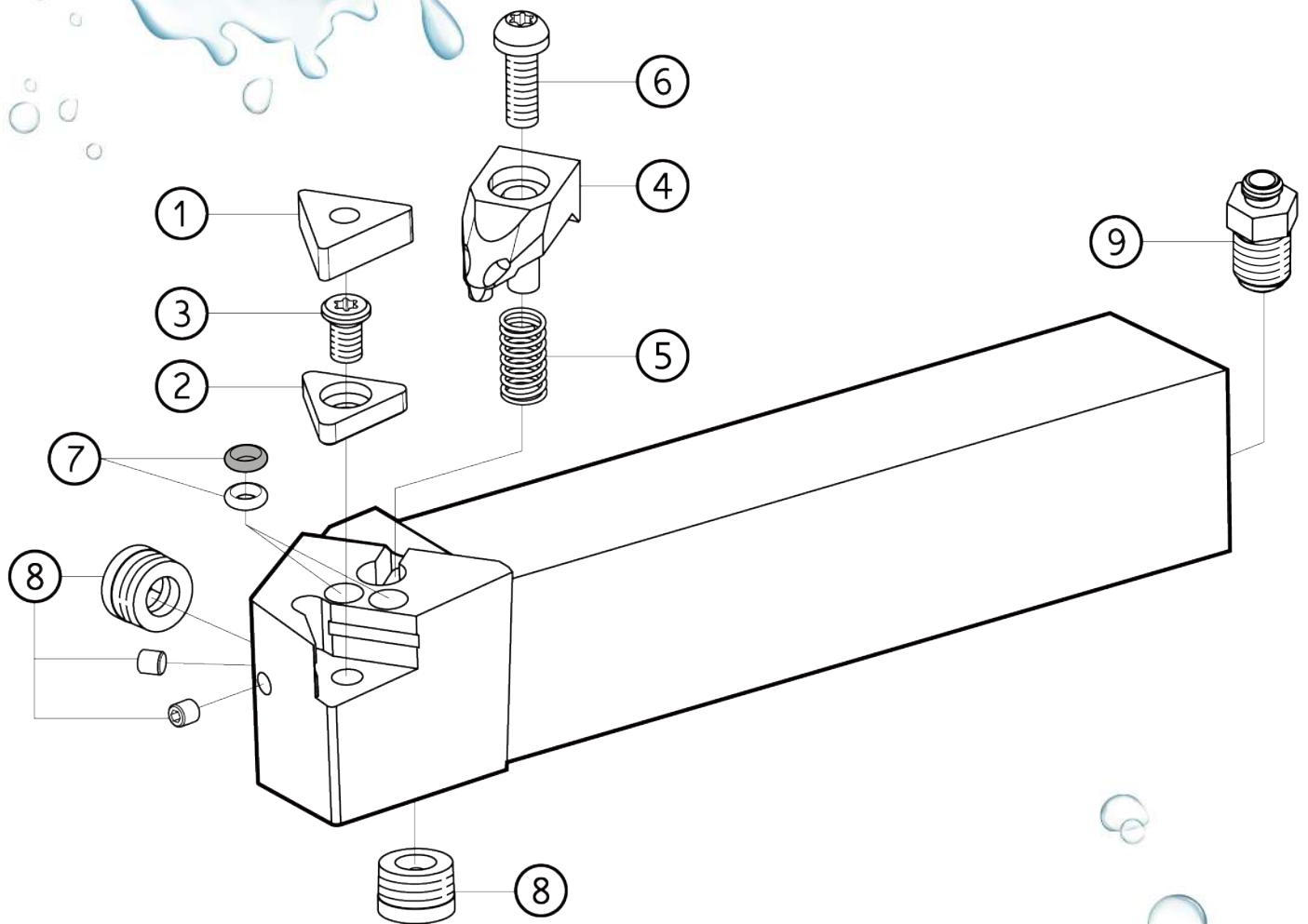

① 刀片 Insert

② 墊片 Shim

③ 墊片螺絲 Shim Screw

④ 壓板 Clamp

⑤ 壓板彈簧 Clamp Spring

⑥ 壓板螺絲 Clamp Screw

⑦ O型環 O-ring

⑧ 止付螺絲 Coolant Plug

⑨ 轉接頭 Adapters

Turning Tools 外徑車刀

AACLN

95°

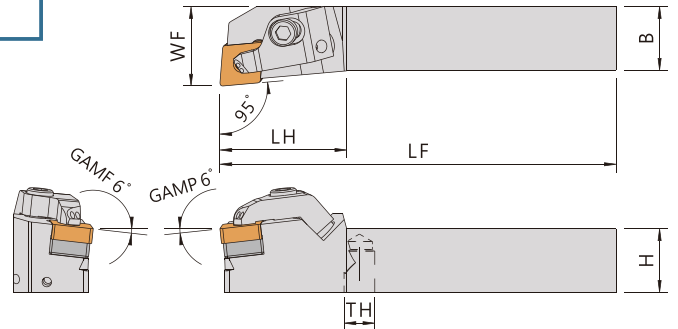
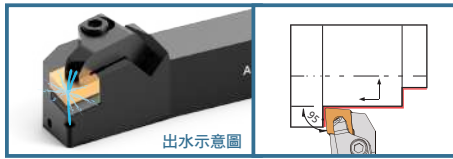

Order No.	Insert	Dimensions(mm)						Shim	Shim Screw	Clamp	Clamp Spring	Clamp Screw	Coolant plug	Wrench
		柄高	柄寬	總長	頭長	寬度	牙孔							
Right / Left	①刀片	H	B	LF	LH	WF	Th	②墊片	③墊片螺絲	④壓板	⑤壓板彈簧	⑥壓板螺絲	⑧止付螺絲	扳手
AACLNR-2020K12WP	CNMG1204	20	20	125	40	25	1/8"	SMC-432	CSF4010	CP-AX01	SP0813	CSH0516	CS9NQ CS9-3003	LW025 LW040
AACLNR-2525M12WP		25	25	150	36	32	1/8"							

WP : Multiple coolant direction 上下雙出水

AATJN

93°

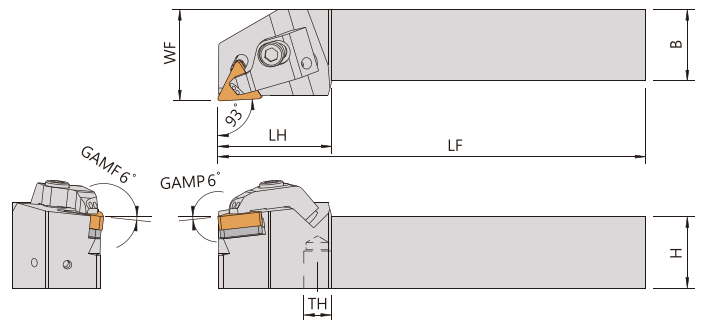
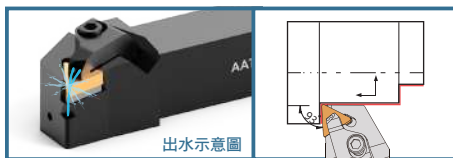

Order No.	Insert	Dimensions(mm)						Shim	Shim Screw	Clamp	Clamp Spring	Clamp Screw	Coolant plug	Wrench
		柄高	柄寬	總長	頭長	寬度	牙孔							
Right / Left	①刀片	H	B	LF	LH	WF	Th	②墊片	③墊片螺絲	④壓板	⑤壓板彈簧	⑥壓板螺絲	⑧止付螺絲	扳手
AATJNR-2020K16WP	TNMG1604	20	20	125	40	25	1/8"	SMT-323	CS40075	CP-AX01	SP0813	CSH0516	CS9NQ CS9-3003	TL-15 LW040
AATJNR-2525M16		25	25	150	40	32	1/8"							
AATJNR-2525M16WP		25	25	150	40	32	1/8"							

WP : Multiple coolant direction 上下雙出水

Turning Tools 外徑車刀

AATQN

105°

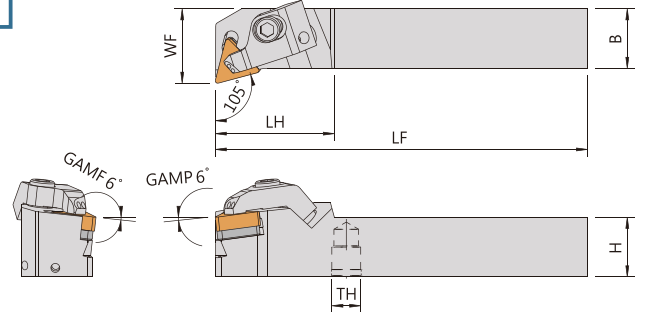
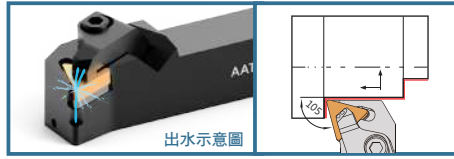

Order No.	Insert	Dimensions(mm)						Shim	Shim Screw	Clamp	Clamp Spring	Clamp Screw	Coolant plug	Wrench
Right / Left	①刀片	柄高	柄寬	總長	頭長	寬度	牙孔	②墊片	③墊片螺絲	④壓板	⑤壓板彈簧	⑥壓板螺絲	⑧止付螺絲	扳手
		H	B	LF	LH	WF	Th							
AATQNR-2020K16WP	TNMG1604	20	20	125	40	25	1/8"	SMT-323	CSA40075	CP-AX01	SP0813	CSH0516	CS9NQ CS9-3003	TL-15 LW040
AATQNR/L-2525M16WP		25	25	150	40	32	1/8"							

WP : Multiple coolant direction 上下雙出水

AAWLN

95°

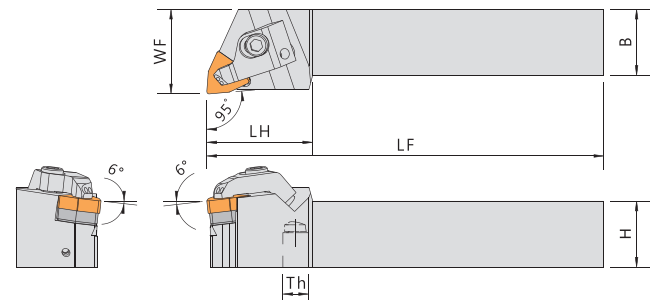

Order No.	Insert	Dimensions(mm)						Shim	Shim Screw	Clamp	Clamp Spring	Clamp Screw	Coolant plug	Wrench
Right / Left	①刀片	柄高	柄寬	總長	頭長	寬度	牙孔	②墊片	③墊片螺絲	④壓板	⑤壓板彈簧	⑥壓板螺絲	⑧止付螺絲	扳手
		H	B	LF	LH	WF	Th							
AAWLNR-2020K08WP	WNMG0804	20	20	125	40	25	1/8"	SMW-432	CSF4010	CP-AX01	SP0710	CSH0516	CS9NQ CS9-3003	LW025 LW040
AAWLNR-2525M08		25	25	150	40	32	1/8"							
AAWLNR/L-2525M08WP		25	25	150	40	32	1/8"							

WP : Multiple coolant direction 上下雙出水

Turning Tools 外徑車刀

ADCLN

95°

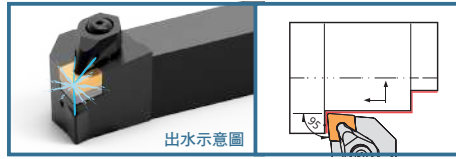

出水示意圖

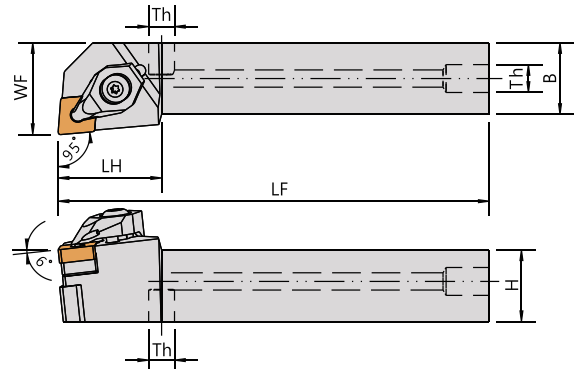
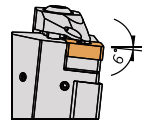
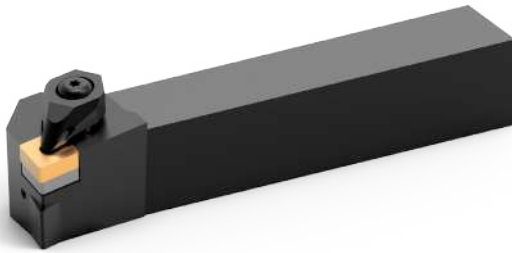

Order No.	Insert	Dimensions(mm)						Shim	Shim Screw	Clamp	Clamp Spring	Clamp Screw	O-ring	Coolant plug	Wrench
		柄高	柄寬	總長	頭長	寬度	牙孔								
Right / Left	①刀片	H	B	LF	LH	WF	Th	②墊片	③墊片螺絲	④壓板	⑤壓板彈簧	⑥壓板螺絲	⑦O型環	⑧止付螺絲	板手
ADCLNR-2020K12WP	CNMG1204	20	20	125	40	25	1/8"	SMC-432	CSF4010	CP-D4AR1 CP-D4AL1	SP0816	CSB0620T	WSS3 WSA5015	CS9NQ CS9-6N CS9-3003	TL-20 LW025 LW040
ADCLNR-2525M12		25	25	150	36	32	1/8"								
ADCLNR/L-2525M12WP		25	25	150	36	32	1/8"								

WP : Multiple coolant direction 上下雙出水

ADDJN

93°

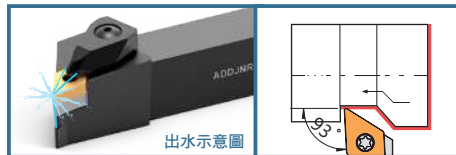

出水示意圖

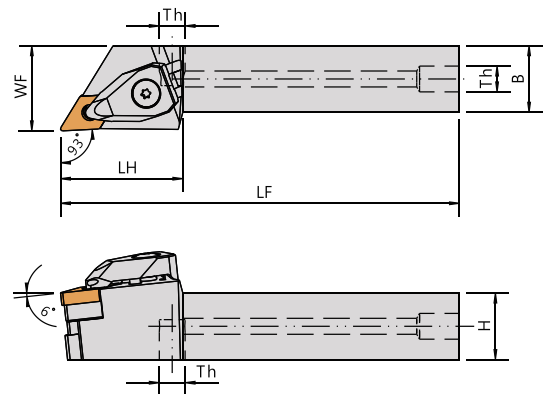
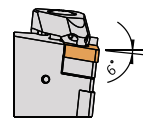

Order No.	Insert	Dimensions(mm)						Shim	Shim Screw	Clamp	Clamp Spring	Clamp Screw	Washer	O-ring	Coolant plug	Wrench
		柄高	柄寬	總長	頭長	寬度	牙孔									
Right / Left	①刀片	H	B	LF	LH	WF	Th	②墊片	③墊片螺絲	④壓板	⑤壓板彈簧	⑥壓板螺絲	C型環	⑦O型環	⑧止付螺絲	板手
ADDJNL-2020K15(04/06)WP	DNMG1504 -SMD463	20	20	125	43	25	1/8"	SMD-4X3	CSF4010	CP-D3AL1	SP0816	CSB0620P	ER04	WSS3 WSA5015	CS9NQ CS9-3003	TL-20 LW025 LW040
ADDJNR-2020M1504(04/06)		20	20	150	43	25	1/8"									
ADDJNR/L-2525M15(04/06)WP	DNMG1506 -SMD443	25	25	150	43	32	1/8"			CP-D3AR1 CP-D3AL1						

WP : Multiple coolant direction 上下雙出水

Turning Tools 外徑車刀

ADDQN

107.5°

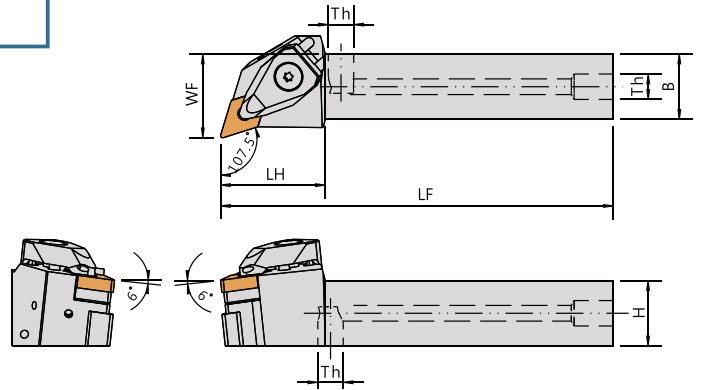
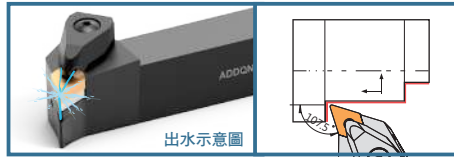

Order No.	Insert	Dimensions(mm)						Shim	Shim Screw	Clamp	Clamp Spring	Clamp Screw	Washer	O-ring	Coolant plug	Wrench
		柄高	柄寬	總長	頭長	寬度	牙孔									
Right / Left	①刀片	H	B	LF	LH	WF	Th	②墊片	③墊片螺絲	④壓板	⑤壓板彈簧	⑥壓板螺絲	C型環	⑦O型環	⑧止付螺絲	扳手
		H	B	LF	LH	WF	Th									
ADDQNR-2525M1504WP	DNMG1504	25	25	150	40	32	1/8"	SMD-463	CSF4010	CP-D3AR1	SP030	CSB0620P	ER04	WSS3 WSA5015	CS9NQ CS9-3003	TL-20 LW025 LW040

WP : Multiple coolant direction 上下雙出水

ADTEN

60°

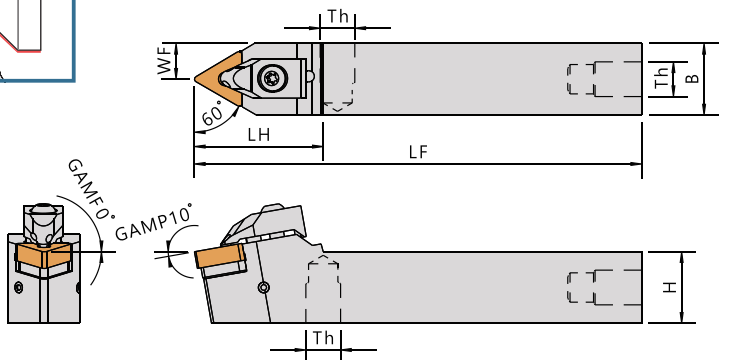
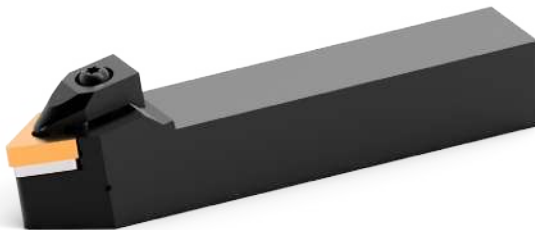
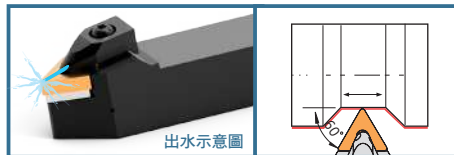

Order No.	Insert	Dimensions(mm)						Shim	Shim Screw	Clamp	Clamp Spring	Clamp Screw	O-ring	Coolant plug	Wrench
		柄高	柄寬	總長	頭長	寬度	牙孔								
Right / Left	①刀片	H	B	LF	LH	WF	Th	②墊片	③墊片螺絲	④壓板	⑤壓板彈簧	⑥壓板螺絲	⑦O型環	⑧止付螺絲	扳手
		H	B	LF	LH	WF	Th								
ADTENN-1620JX16	TNMG1604	16	20	120	36	10	1/8"	SMT-323	CSA40075	CP-D2AR1	SP0612	CSB0415T	WSS3 WSA5015	CS9NQ CS9-3003	TL-15 LW015 LW040

ADTJN

93°



出水示意圖

出水實況

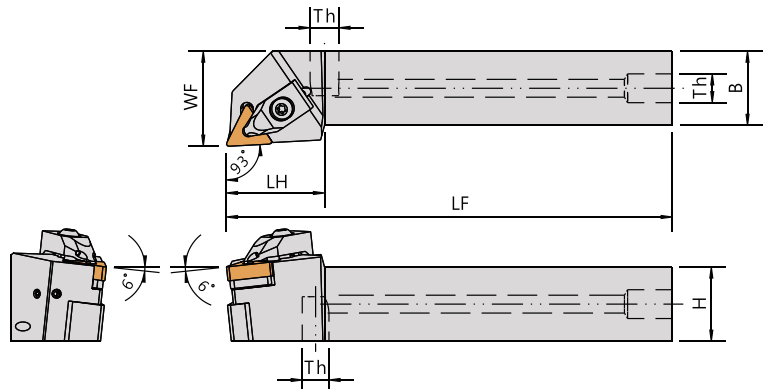
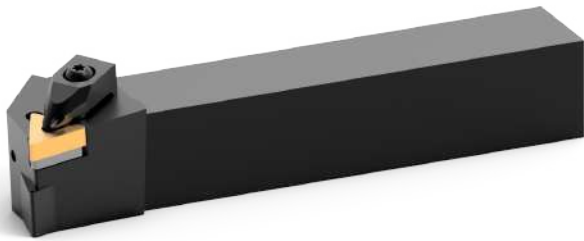

Order No.	Insert	Dimensions(mm)						Shim	Shim Screw	Clamp	Clamp Spring	Clamp Screw	O-ring	Coolant plug	Adapter	Wrench
Right / Left	①刀片	柄高	柄寬	總長	頭長	寬度	牙孔	②墊片	③墊片螺絲	④壓板	⑤壓板彈簧	⑥壓板螺絲	⑦O型環	⑧止付螺絲	⑨轉接頭	板手
		H	B	LF	LH	WF	Th									
ADTJNR-1212K16N	TNMG1604	12	12	125	33	12	5/16"	SMT-323	CSA40075	CP-D2AR1 CP-D2AL1	SP0612	CSB0415T	WSS3 WSA5015	CS9NN CS9-3003	AA-NP	TL-15 LW040
ADTJNR-1616K16N		16	16	125	33	16	1/8"							CS9NQ CS9-3003		
ADTJNR-2020K16WP		20	20	125	33	25	1/8"									
ADTJNR-2525M16		25	25	150	33	32	1/8"									
ADTJNR/L-2525M16WP		25	25	150	33	32	1/8"									

WP : Multiple coolant direction 上下雙出水

ADTQN

105°

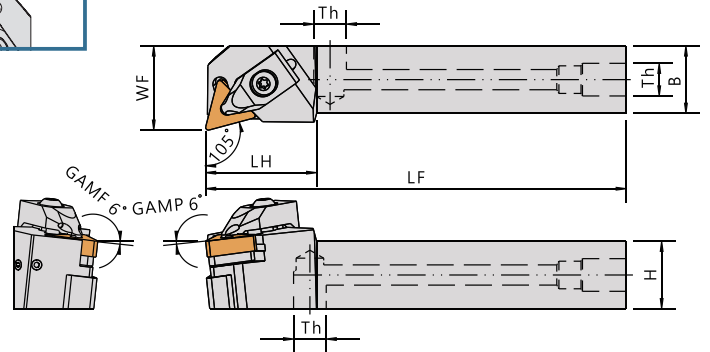
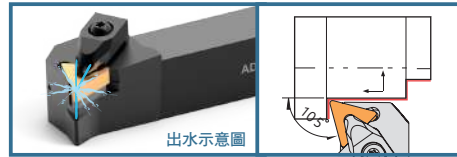

Order No.	Insert	Dimensions(mm)						Shim	Shim Screw	Clamp	Clamp Spring	Clamp Screw	O-ring	Coolant plug	Wrench
		柄高	柄寬	總長	頭長	寬度	牙孔								
ADTQNR/L-2020K16WP	TNMG1604	20	20	125	25	33	1/8"	SMT-323	CSA40075	CP-D2AR1	SP0612	CSB0415T	WSS3	CS9NQ	TL-15
ADTQNR-2525M16WP		25	25	150	32	33	1/8"			CP-D2AL1					

WP : Multiple coolant direction 上下雙出水

ADVJN

93°

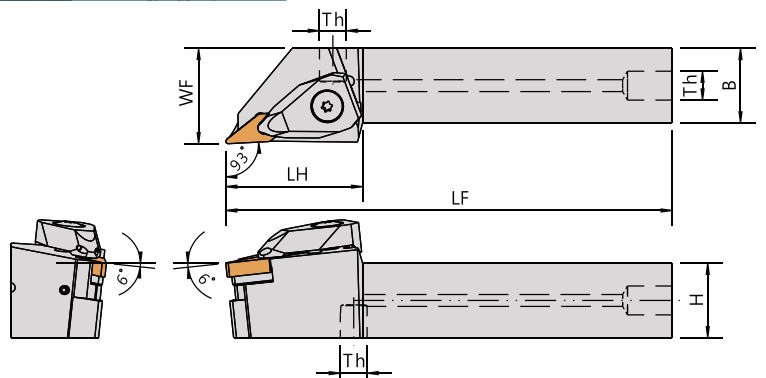

Order No.	Insert	Dimensions(mm)						Shim	Shim Screw	Clamp	Clamp Spring	Clamp Screw	Washer	O-ring	Coolant plug	Wrench
		柄高	柄寬	總長	頭長	寬度	牙孔									
ADVJNR/L-2020K16WP	VNMG1604	20	20	125	50	25	1/8"	SMV-322	CSA40075	CP-D3AR1	SP030	CSB0620P	ER04	WSP25	CS9NQ	TL-20
ADVJNR-2525M16WP		25	25	150	46	32	1/8"			CP-D3AL1						CS9-3003

WP : Multiple coolant direction 上下雙出水

Turning Tools 外徑車刀

ADWLN

95°

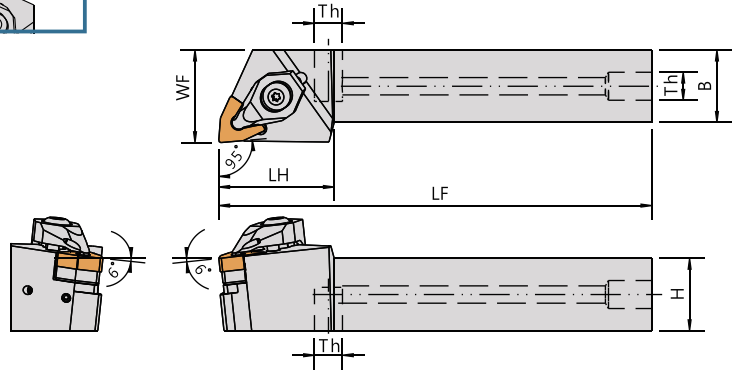
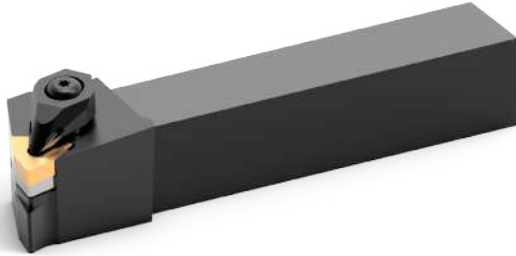
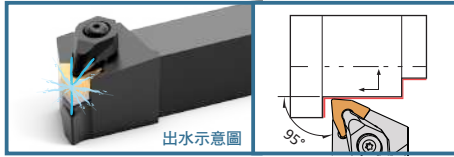

Order No.	Insert	Dimensions(mm)						Shim	Shim Screw	Clamp	Clamp Spring	Clamp Screw	O-ring	Coolant plug	Wrench
Right / Left	①刀片	柄高	柄寬	總長	頭長	寬度	牙孔	②墊片	③墊片螺絲	④壓板	⑤壓板彈簧	⑥壓板螺絲	⑦O型環	⑧止付螺絲	板手
		H	B	LF	LH	WF	Th								
ADWLN-2020K08WP	WNMG080408	20	20	125	36	25	1/8"	SMW-432	CSF4010	CP-D4AR1	SP0816	CSB0620T	WSS3 WSA5015	CS9NQ CS9-3003	TL-20 LW025 LW040
ADWLN-2525M08		25	25	150	36	32	1/8"			CP-D2AR1					
ADWLN/L-2525M08WP		25	25	150	36	32	1/8"			CP-D4AR/L1					

WP : Multiple coolant direction 上下雙出水

AMCLN

95°

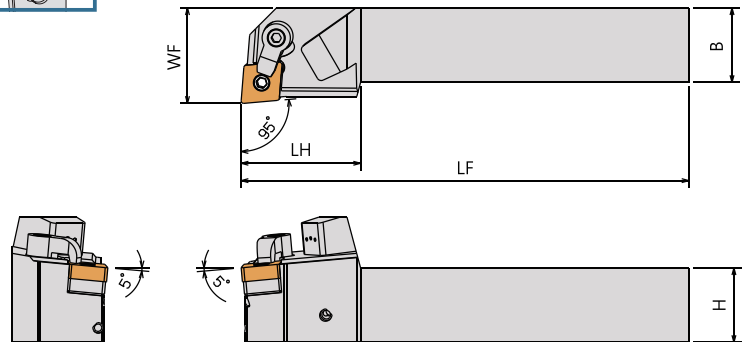
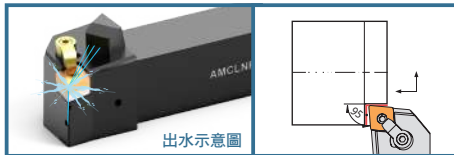

Order No.	Insert	Dimensions(mm)						Shim	Shim Screw	Clamp	Clamp Screw	Coolant plug	Wrench
Right / Left	①刀片	柄高	柄寬	總長	頭長	寬度	牙孔	②墊片	③墊片螺絲	④壓板	⑥壓板螺絲	⑧止付螺絲	板手
		H	B	LF	LH	WF	Th						
AMCLN-2525M12WP	CNMG1204	25	25	150	40	32	1/8"	SMC-432	LCS-617	CP50-22	CS7-6030	CS9NQ CS9-3003	LW030 LW040
AMCLN-3232P12WP		32	32	170	40	40	1/8"						

WP : Multiple coolant direction 上下雙出水

AMDJN

93°

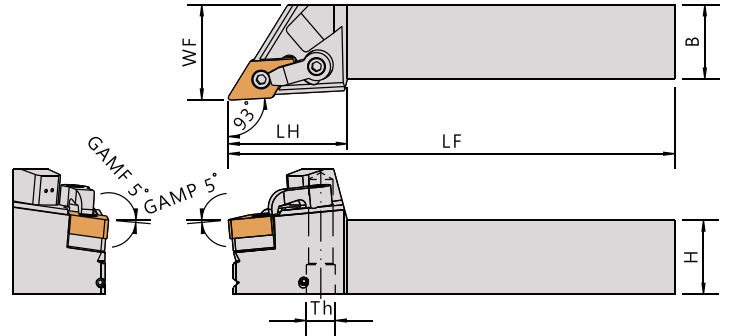
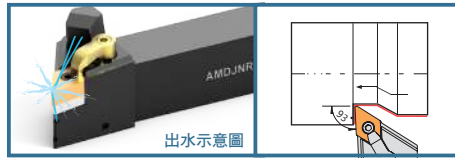

Order No.	Insert	Dimensions(mm)						Shim	Shim Screw	Clamp	Clamp Screw	Coolant plug	Wrench
		柄高	柄寬	總長	頭長	寬度	牙孔						
Right / Left	①刀片	H	B	LF	LH	WF	Th	②墊片	③墊片螺絲	④壓板	⑥壓板螺絲	⑧止付螺絲	板手
AMDJNR-2525M15WP	DNMG1504 -SMD463 DNMG1506 -SMD443	25	25	150	40	32	1/8"	SMD-4X3	LCS-619	CP50-24	CS7-6030	CS9NQ CS9-3003	LW030 LW040

WP : Multiple coolant direction 上下雙出水

AMTJN

93°

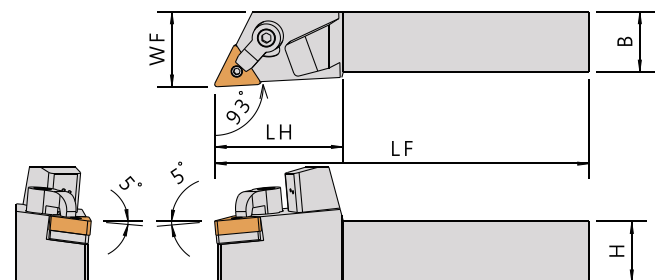
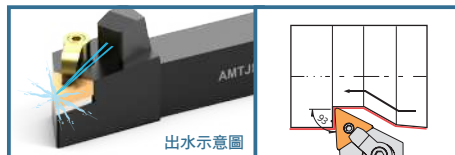

Order No.	Insert	Dimensions(mm)						Shim	Shim Screw	Clamp	Clamp Screw	Coolant plug	Wrench
		柄高	柄寬	總長	頭長	寬度	牙孔						
Right / Left	①刀片	H	B	LF	LH	WF	Th	②墊片	③墊片螺絲	④壓板	⑥壓板螺絲	⑧止付螺絲	板手
AMTJNR-2020K16	TNMG1604	20	20	125	43	25	1/8"	SMT-322	LCS-513	CP50-22	CS7-6024	CS9NQ CS9-3003	LW020 LW030 LW040

Turning Tools 外徑車刀

AMVJN

93°

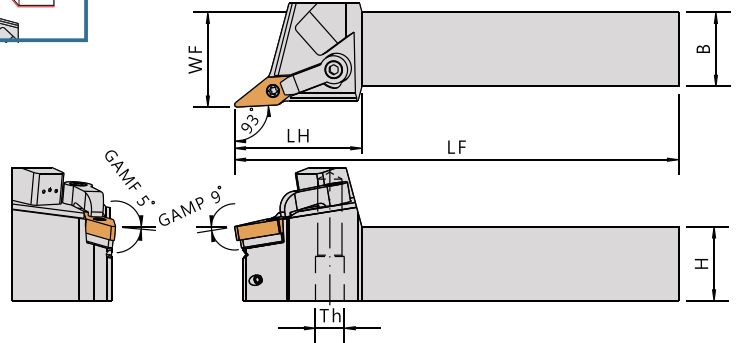
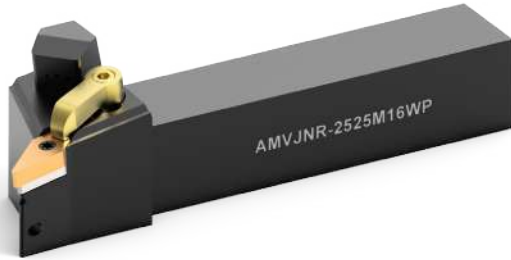
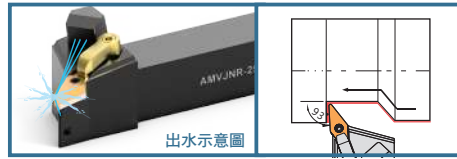

Order No.	Insert	Dimensions(mm)						Shim	Shim Screw	Clamp	Clamp Screw	Coolant plug	Wrench
Right / Left	①刀片	柄高	柄寬	總長	頭長	寬度	牙孔	②墊片	③墊片螺絲	④壓板	⑥壓板螺絲	⑧止付螺絲	板手
AMVJNR-2020K16WP	VNMG1604	20	20	125	43	25	1/8"	SMV-322	LCS-513	CP50-25	CS7-6030	CS9NQ CS9-3003	LW020 LW030 LW040
AMVJNR-2525M16WP		25	25	150	43	32	1/8"						

WP : Multiple coolant direction 上下雙出水

APCLN

95°

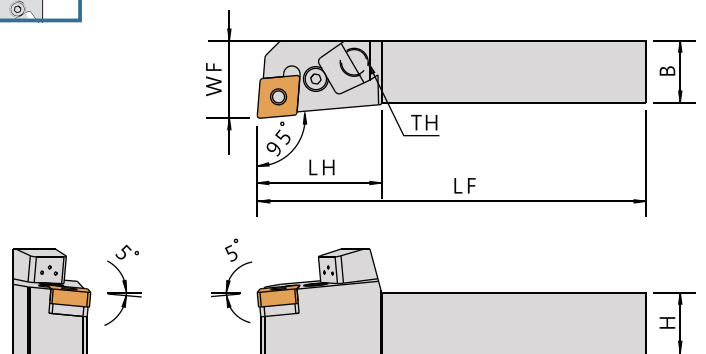
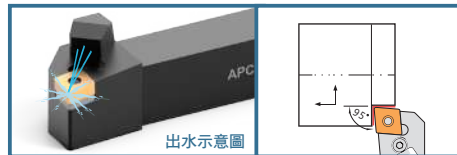

Order No.	Insert	Dimensions(mm)						Shim	Shim Screw	Clamp	Clamp Screw	Coolant plug	Wrench
Right / Left	①刀片	柄高	柄寬	總長	頭長	寬度	牙孔	②墊片	③墊片螺絲	④壓板	⑥壓板螺絲	⑧止付螺絲	板手
APCLNR-2020K12H	CNMG1204	20	20	125	40	25	1/8"	SMC-422	CS-LSP4	CP-LL4	CS-LS4	CS9NQ CS9-3003	LW030 LW040
APCLNR-2525M12		25	25	150	36	32	1/8"						
APCLNR-3232P12		32	32	170	36	40	1/8"						

ASCLC

95°

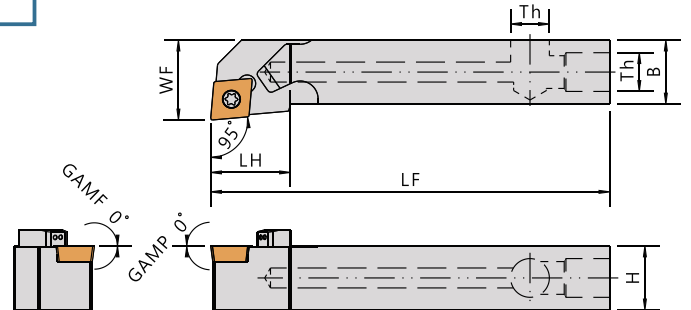
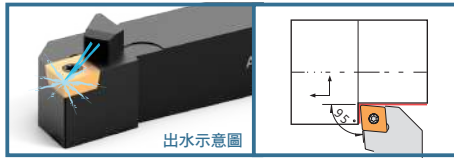

Order No.	Insert	Dimensions(mm)						Insert Screw	Coolant plug	Adapter	Wrench
		柄高	柄寬	總長	頭長	寬度	牙孔				
Right / Left		H	B	LF	LH	WF	Th				
ASCLCR-1212H09	CCMT09T3	12	12	100	20	16	5/16"	CS35090	CS9NN CS9-4004	-	FT-15 LW040
ASCLCR-1616H09		16	16	100	20	20	1/8"				

ASDNC

62.5°

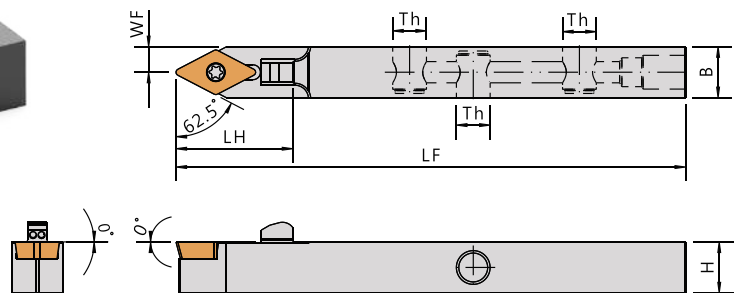
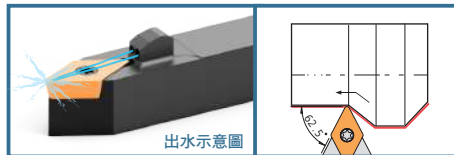

Order No.	Insert	Dimensions(mm)						Insert Screw	Coolant plug	Adapter	Wrench
		柄高	柄寬	總長	頭長	寬度	牙孔				
Right / Left		H	B	LF	LH	WF	Th				
ASDNCN-1212H11A	DCMT11T3	12	12	100	27.5	6	5/16"	CS35119S	CS9NN CS9-4004	AA-NP	FT-15 LW040

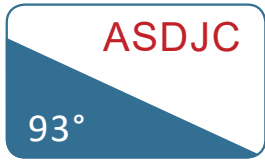

ASDJC-N

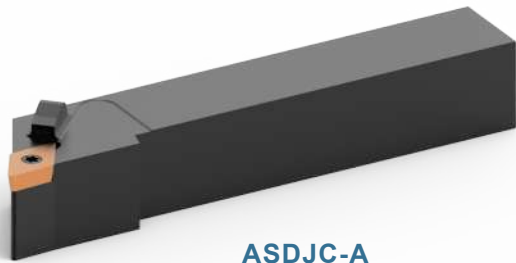
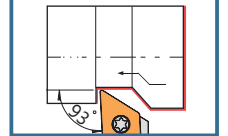
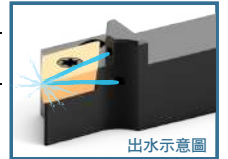
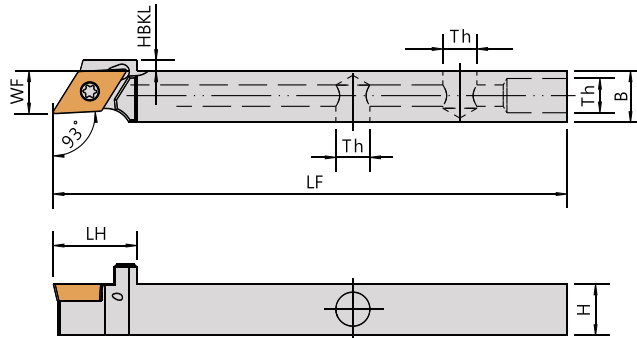

ASDJC-A

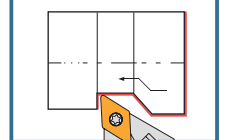
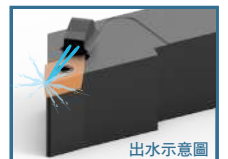
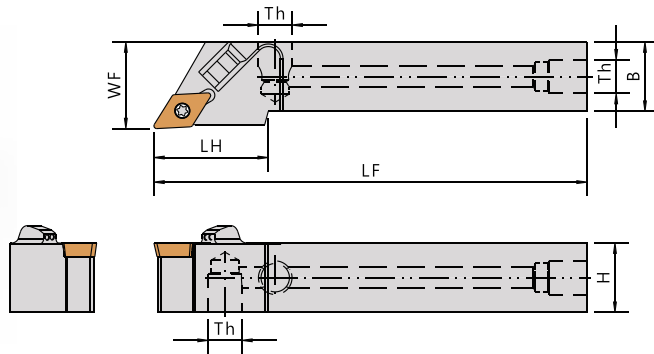

ASDJC-NA

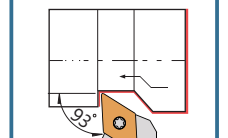
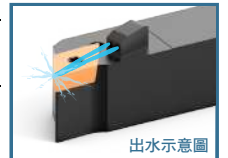
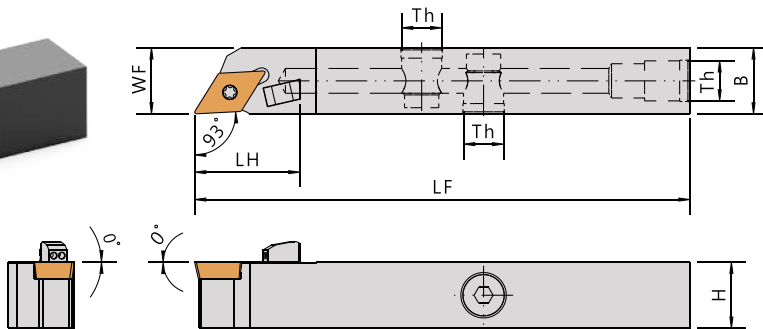

Order No.	Insert	Dimensions(mm)							Insert Screw	Coolant plug	Adapter	Wrench	
		柄高	柄寬	總長	頭長	寬度	背面長度差	牙孔				刀片螺絲	止付螺絲
Right / Left		H	B	LF	LH	WF	HBK	Th					
ASDJCR-1212H11N	DCMT11T3	12	12	100	24	12	3	5/16"	CS35119S		AA-NP		
ASDJCR-1212H11-F10		12	12	100	19.5	10	4	5/16"					
ASDJCR/L-1212JX11NA		12	12	120	19.5	10	4	5/16"					
ASDJCR-1616H11N		16	16	100	24	16	-	1/8"	CS35095		-		
ASDJCR-1616JX11NA		16	16	120	19.5	14	-	1/8"					
ASDJCR-2020K11-A		20	20	125	33	25	-	1/8"	CS35119S		-		
ASDJCR-2525M11-A		25	25	150	38	32	-	1/8"					

Turning Tools 外徑車刀

ASTUP

93°

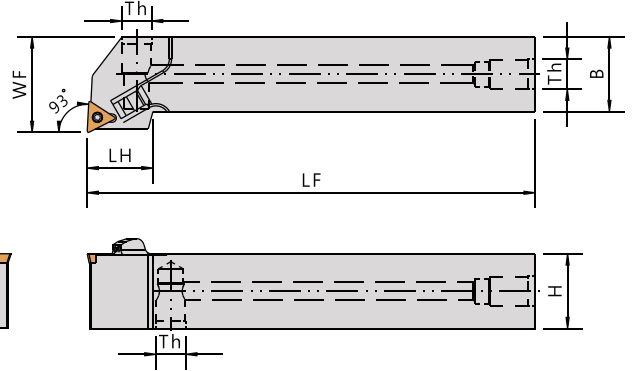
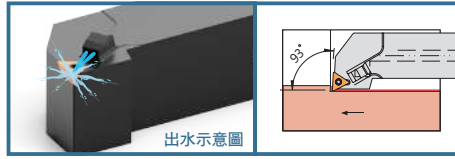

Order No.	Insert	Dimensions(mm)						Insert Screw	Coolant plug	Wrench	
		柄高	柄寬	總長	頭長	寬度	牙孔			刀片螺絲	止付螺絲
Right / Left		H	B	LF	LH	WF	Th				
ASTUPR-2525M11-A	TPMT1103	25	25	150	22	32	1/8"	CSA30070	CS9NQ CS9-5005	FT-10 LW025 LW040	

ASVJB

93°

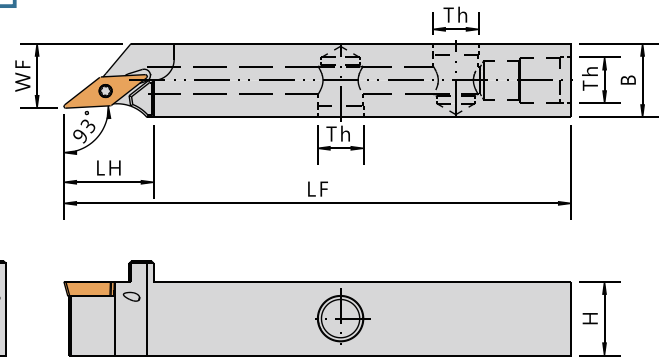
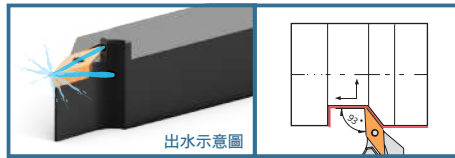

Order No.	Insert	Dimensions(mm)						Insert Screw	Coolant plug	Wrench	
		柄高	柄寬	總長	頭長	寬度	牙孔			刀片螺絲	止付螺絲
Right / Left		H	B	LF	LH	WF	Th				
ASVJBR-1212JX11NA	VBMT1103	12	12	120	19.5	10	5/16"	CS25055PS	CS9NN CS9-4004	FT-7	LW040
ASVJBR-1616JX11NA		16	16	120	19.5	14	1/8"		CS9NQ CS9-5005	FT-7	LW050

ASVJC
ASVJC-N/NA

93°

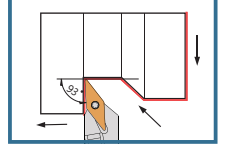
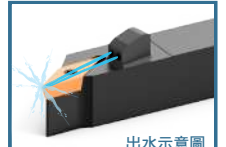
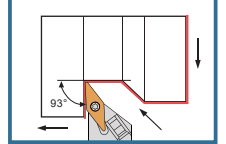
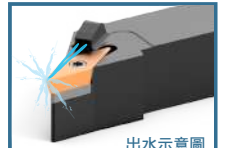
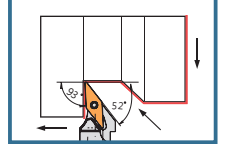
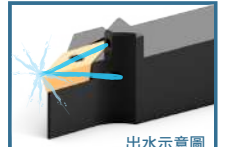
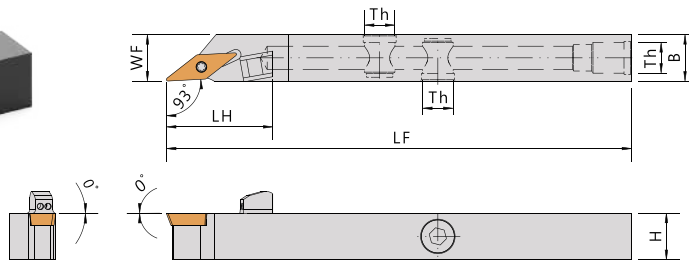
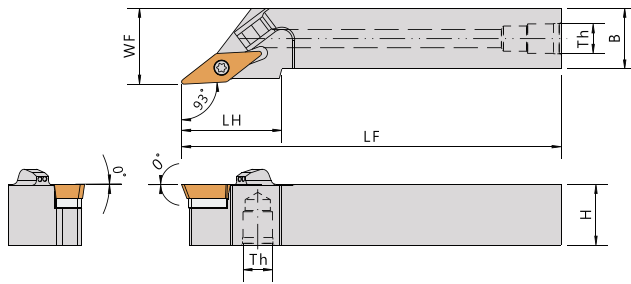
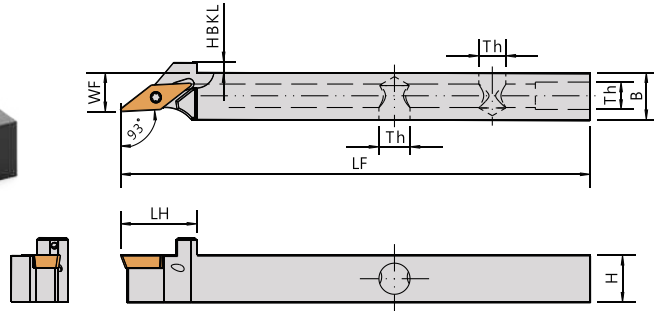
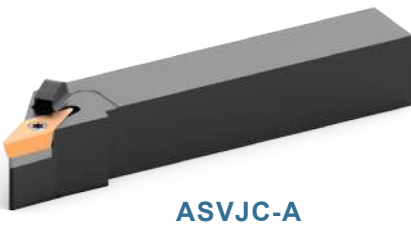

Order No.	Insert	Dimensions(mm)							Shim	Shim Screw	Insert Screw	Coolant plug	Adapter	Wrench	
		柄高	柄寬	總長	頭長	寬度	背面長度差	牙孔						墊片	墊片螺絲
Right / Left		H	B	LF	LH	WF	HBKL	Th							
ASVJCR-1010H11-F08	VCMT1103	10	10	100	19.5	8	2.5	5/16"	-	-	CS25055PS	CS9NN CS9-3003	AA-NP	FT-7	LW040
ASVJCR-1212-11NACB		12	12	140	24	12	4.5	5/16"	-	-	CS25055PS	CS9NN CS9-4004		FT-7	LW040
ASVJCR/L-1212H11-F10		12	12	100	19.5	10	2.5	5/16"	-	-	CS25055PS	CS9NN CS9-3003		FT-7	LW040
ASVJCR-1212H11N		12	12	100	27.5	12	-	5/16"	-	-	CS25060	CS9NN CS9-3003		FT-7	LW040
ASVJCR-1212JX11NA		12	12	120	27.5	12	-	5/16"	-	-	CS25060	CS9NN CS9-3003		FT-7	LW040
ASVJCR/L-1616H11-F14		16	16	100	36	14	-	1/8"	-	-	CS25060	CS9NQ CS9-3003		FT-7	LW040
ASVJCR-1616-11NACB	VCMT1604	16	16	140	27.5	16	-	1/8"	-	-	CS25060	CS9NQ CS9-3003	-	FT-7	LW040
ASVJCR/L-2020K16-A		20	20	125	33	25	-	1/8"	SMV-321	SN535	CS35117S	CS9NQ	FT-15	LW040	
ASVJCR-2020K16-F18		20	20	125	25	18	-	1/8"	-	-	CS35117S	CS9NQ CS9-3003	FT-15	LW040	
ASVJCR/L-2525M16-A		25	25	150	33	32	-	1/8"	SMV-321	SN535	CS35117S	CS9NQ	FT-15	LW040	

Turning Tools 外徑車刀

ASVJP

93°

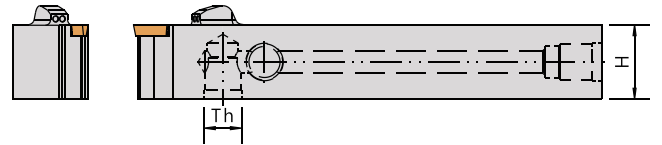
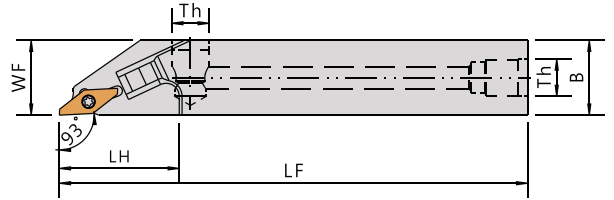
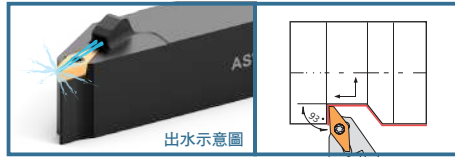

Order No.	Insert	Dimensions(mm)						Insert Screw	Coolant plug	Adapter	Wrench	
		柄高	柄寬	總長	頭長	寬度	牙孔				轉接頭	板手
Right / Left		H	B	LF	LH	WF	Th					
ASVJPR-1010JX10	VPGT1003	10	10	120	30	10	5/16"	CS25060	CS9NN CS9-4004	AA-NP	FT-7	LW040
ASVJPR-1212JX10		12	12	120	30	12	5/16"					
ASVJPR-1616JX10		16	16	120	32	16	1/8"		CS9NQ CS9-4004	-	FT-7	LW040
ASVJPR-2020K10		20	20	125	32	20	1/8"		CS9NQ			

ASVKB

54.5°

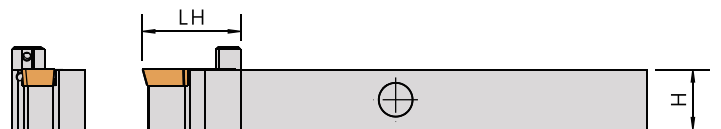
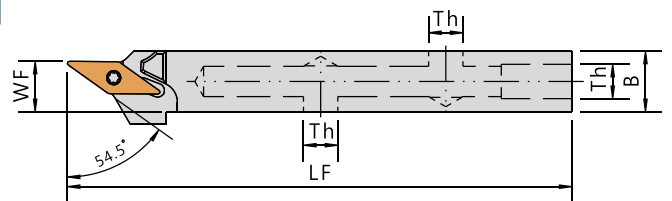
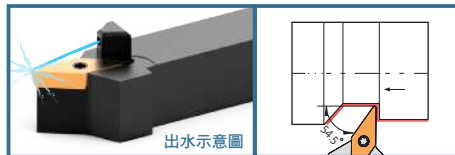

Order No.	Insert	Dimensions(mm)						Insert Screw	Coolant plug	Adapter	Wrench	
		柄高	柄寬	總長	頭長	寬度	牙孔				轉接頭	板手
Right / Left		H	B	LF	LH	WF	Th					
ASVKBR-1212JX11-F10	VBMT1103	12	12	120	19.5	10	5/16"	CS25055PS	CS9NN CS9-3003	AA-NP	FT-7	LW040

ASVKC

90.5°

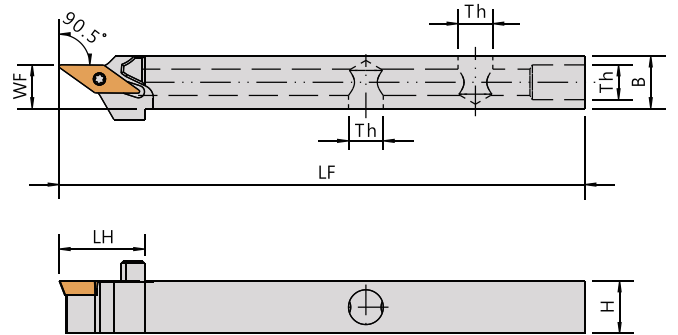
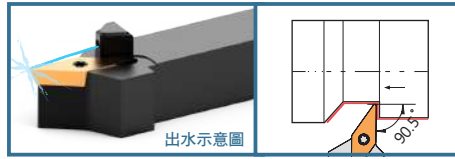

Order No.	Insert	Dimensions(mm)						Insert Screw	Coolant plug	Adapter	Wrench	
		柄高	柄寬	總長	頭長	寬度	牙孔				刀片螺絲	止付螺絲
Right / Left		H	B	LF	LH	WF	Th					
ASVKCR-1212H11	VCMT1103	12	12	100	19.5	10	5/16"	CS25055PS	CS9NN CS9-3003	AA-NP	FT-7	LW040
ASVKCR-1212JX11-F10		12	12	120	19.5	10	5/16"					
ASVKCR/L-1616JX11		16	16	120	19.5	9	1/8"				CS9NQ CS9-3003	-

ATJNR

93°

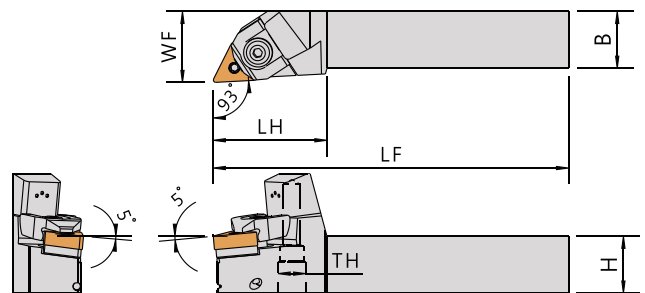
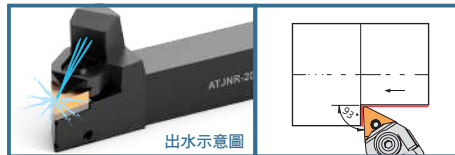

Order No.	Insert	Dimensions(mm)						Shim	Screw	Clamp	Clamp Screw	Washer	O-ring	Coolant plug	Wrench
		柄高	柄寬	總長	頭長	寬度	牙孔								
Right / Left		H	B	LF	LH	WF	Th								
ATJNR-3232P16WP	TNMG1604	32	32	170	40	40	1/8"	SMT-322	LCS-513	MTW-30	CSE5026	ER04	WS06	CS9-3003 CS9NQ	LW025 LW030 LW040

WP : Multiple coolant direction 上下雙出水

AWLNR
95°

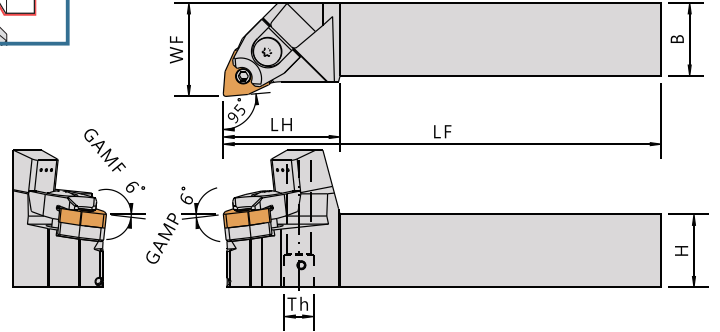
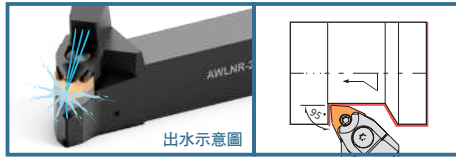

Order No.	Insert	Dimensions(mm)						Shim	Shim Screw	Clamp	Clamp Spring	Clamp Screw	O-ring	Coolant plug	Wrench	
		柄高	柄寬	總長	頭長	寬度	牙孔								墊片	墊片螺絲
Right / Left		H	B	LF	LH	WF	Th									
AWLNR-2525M08W		25	25	150	40	32	1/8"								TL-25	LW025 LW040
AWLNR-2525M08WP	WNMG0804	25	25	150	40	32	1/8"	SMW-433	LCS-520N	MTW-40	SP0816	CSB0623T	WS06	CS9NQ	TL-25	LW025 LW040
AWLNR-3232P08WP		32	32	170	40	40	1/8"								TL-25	LW025 LW040

WP : Multiple coolant direction 上下雙出水

Boring Bar 內孔車刀

L-SCLC-V

95°

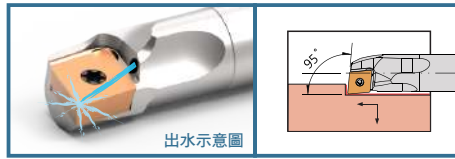

出水示意圖

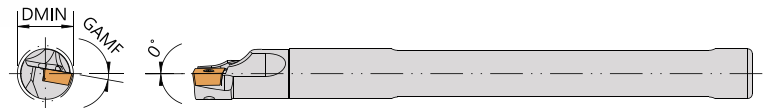
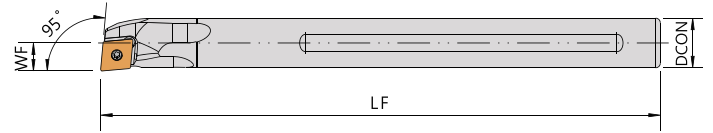

Order No.	Insert	Dimensions(mm)						Insert Screw	Wrench
		柄徑	工作寬度	長度	頭長	最小加工徑	徑向前角		
Right / Left		DCON	WF	LF	LH	DMIN	GAMF		
L08H-SCLCR06-10V	CCMT0602	8	5	100	20	10	14°	CS25050	FT-7
L10K-SCLCR06-12V		10	6	125	20	12	12°		
L12M-SCLCR09-14V	CCMT09T3	12	7	150	-	14	14°	CS35075	FT-15
L16Q-SCLCR09-18V		16	9	180	31	18	10°		

L-SDUC-V

93°

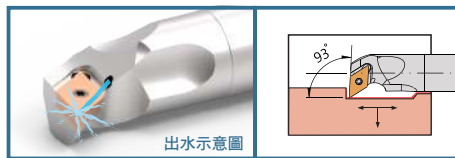

出水示意圖

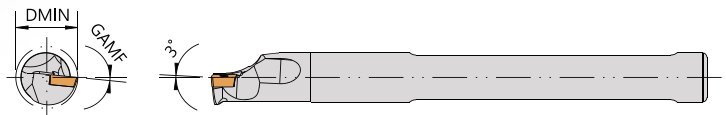
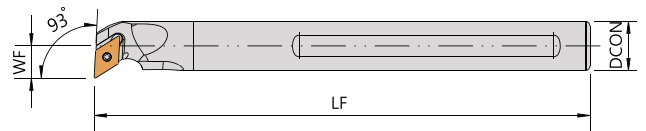

Order No.	Insert	Dimensions(mm)						Insert Screw	Wrench
		柄徑	工作寬度	長度	頭長	最小加工徑	徑向前角		
Right / Left		DCON	WF	LF	LH	DMIN	GAMF		
L20R-SDUCR11V	DCMT11T3	20	13	200	40	25	5.75°	CS35095	FT-15

Boring Bar 內孔車刀

L-STLC-V

95°

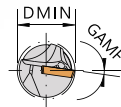
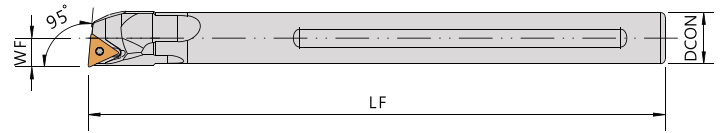
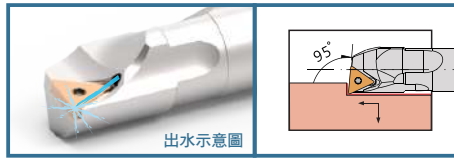

Order No.	Insert	Dimensions(mm)						Insert Screw	Wrench
		柄徑	工作寬度	長度	頭長	最小加工徑	徑向前角		
Right / Left		DCON	WF	LF	LH	DMIN	GAMF	刀片螺絲	扳手
L08H-STLCR09-10V	TCMT0902	8	5	100	20	10	14°	CS22050	
L10K-STLCR09-12V		10	6	125	25	12	12°		
L12M-STLCR11-14V	TCMT1102	12	7	150	25	14	10°		
L16Q-STLCR11-18V		16	9	180	31	18	8°		

L-STUP-V

93°

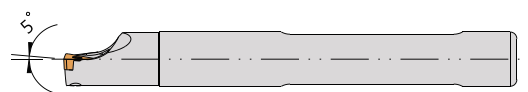
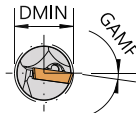
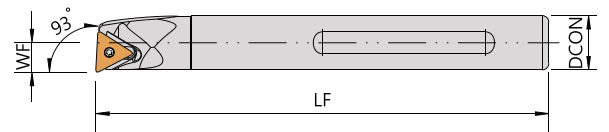
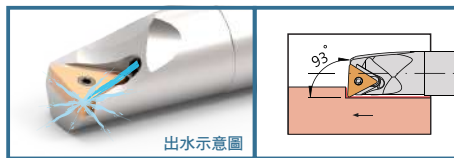

Order No.	Insert	Dimensions(mm)						Insert Screw	Wrench
		柄徑	工作寬度	長度	頭長	最小加工徑	徑向前角		
Right / Left		DCON	WF	LF	LH	DMIN	GAMF	刀片螺絲	扳手
L12H-STUPR09-13V-L21	TPMT0902	12	6.5	100	21	13	8°	CS25065	FT-8

Threading Tools 牙刀

ASER
ASER-N/NA

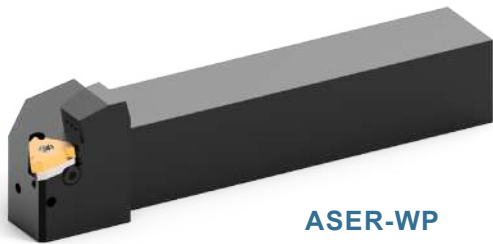
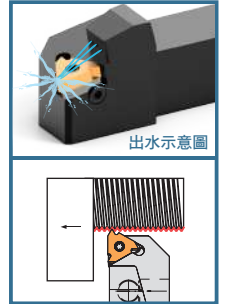
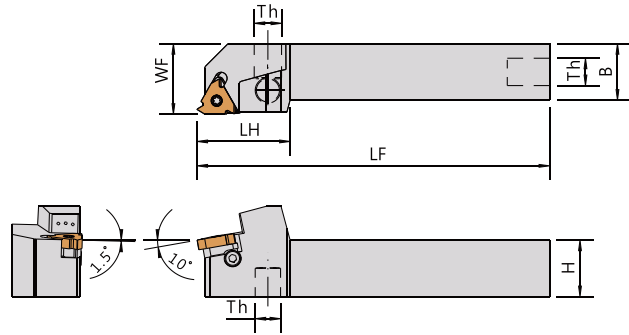

ASER-WP

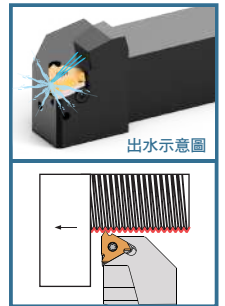
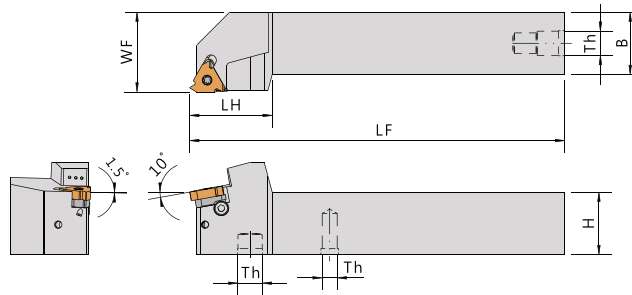

ASER-NA

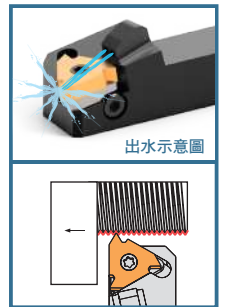
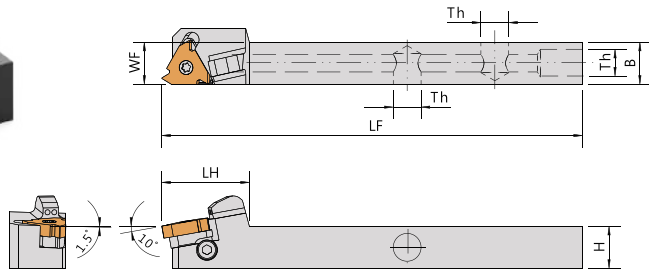

Order No.	Insert	Dimensions(mm)						Shim		Screw	Insert Screw	Coolant plug	Wrench	
		柄高	柄寬	總長	頭長	寬度	牙孔	墊片		螺絲	刀片螺絲	止付螺絲	板手	
Right / Left		H	B	LF	LH	WF	Th	Shim R	Shim L					
ASER-2020K16A	16ER	20	20	125	33	25	1/8"	AE16	AI16	CSH0306	CS35117S	CS9NQ CS9-3003	FT-15	LW025 LW050
ASER-2525M16WP		25	25	150	33	32	1/8"							

WP : Multiple coolant direction 上下雙出水

Order No.	Insert	Dimensions(mm)						Shim		Screw	Insert Screw	Coolant plug	Adapter	Wrench	
		柄高	柄寬	總長	頭長	寬度	牙孔	墊片		螺絲	刀片螺絲	止付螺絲	轉接頭	板手	
Right / Left		H	B	LF	LH	WF	Th	Shim R	Shim L						
ASER-1212JX16NA	16ER	12	12	120	25	12	5/16"	AE16	AI16	CSH0306	CS35117S	CS9NN CS9-4004	AA-NP	FT-15	LW025 LW040
ASER-1616JX16NA		16	16	120	25	12	1/8"								
ASER-2020K16NA		20	20	125	26	20	1/8"								
ASER-2525M16NA		25	25	150	26	25	1/8"								

Grooving Tools 槽刀

ACGWS / AEVSC/M

TUNGALOY/KENAMETAL / WIDIA



ACGWS



AEVSM

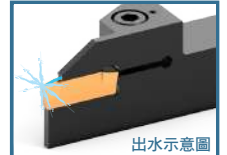
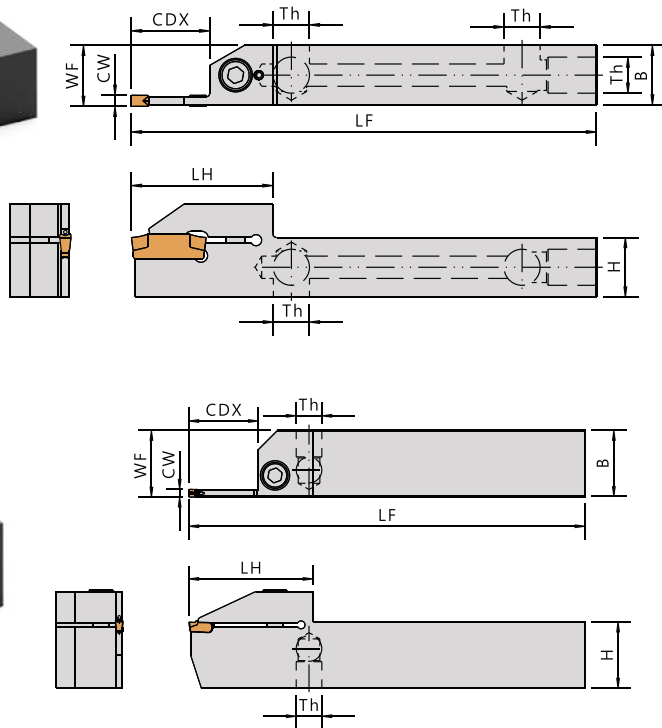

出水示意圖

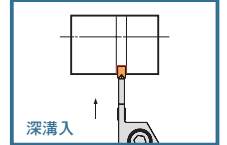

深溝入

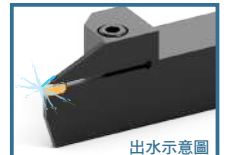

出水示意圖

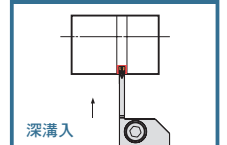

深溝入

▼Recommended Inserts 建議刀片品牌：TUNGALOY

Order No.	Insert	Dimensions(mm)								Insert Screw	Coolant plug	Wrench
		柄高	柄寬	總長	寬度	頭長	切寬	切深	牙孔			
Right / Left		H	B	LF	WF	LH	CW	CDX	Th			
ACGWSR16B-3D40J	WGE30 GH730	16	16	125	16	38	3	20	1/8"	CSH0516	CS9NQ CS9-3003 CS9-25025	LW040
ACGWSR20B-5D50J	WGE50 GH730	20	20	125	20	42	5	25	1/8"			

▼Recommended Inserts 建議刀片品牌：KENAMETAL/WIDIA

Order No.	Insert	Dimensions(mm)								Insert Screw	Coolant plug	Wrench
		柄高	柄寬	總長	寬度	頭長	切寬	切深	牙孔			
Right / Left		H	B	LF	WF	LH	CW	CDX	Th			
AEVSCR/L-1616K0216	EC020 WC020	16	16	125	16.35	27	2	8	1/8"	CS40090	CS9NQ CS9-2002	TL-15 LW040
AEVSMR/L-2525M0326	EC030 WC030	25	25	150	25.25	43	3	13	1/8"	CSH0520		LW040

Grooving Tools 槽刀

ADGT

ISCAR / WIDIA

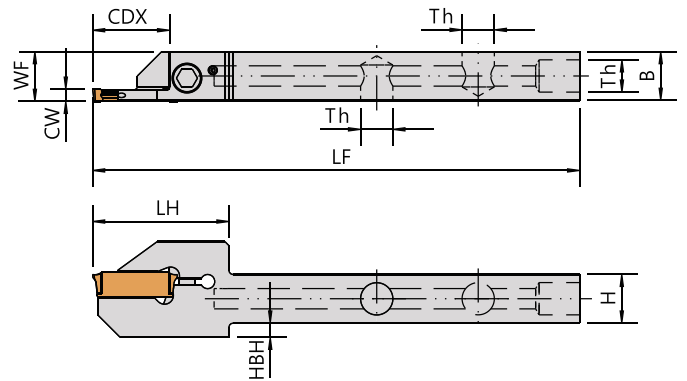
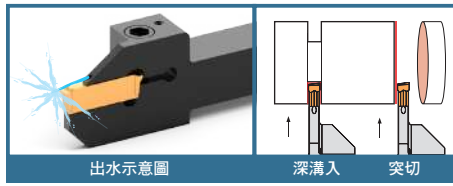

▼Recommended Inserts 建議刀片品牌：ISCAR / WIDIA

Order No.	Insert	Dimensions(mm)									Screw	Coolant plug	Adapter	Wrench
		柄高	柄寬	總長	寬度	頭長	切寬	切深	下巴厚	牙孔				
Right / Left		H	B	LF	WF	LH	CW	CDX	HBH	Th				
ADGTR12B-2D24JS (100L)	DGR 2002Z-6D WDGN2202J	12	12	100	12.28	27	2	12	3.5	5/16"	CSH0412	CS9NN CS9-2002	AA-NP	LW030 LW040
ADGTR/L12B-2D26J		12	12	120	12.28	28	2	13	3.5	5/16"			-	
ADGTR/L12B-2D26JCB		12	12	140	12.28	28	2	13	3.5	5/16"			-	
ADGTR12B-2D26JS		12	12	120	12.28	28	2	13	3.5	5/16"			-	
ADGTL12B-2D26JU		12	12	120	12.28	28	2	13	3.5	5/16"		AA-NP		
ADGTR/L12B-2D36J		12	12	120	12.28	33	2	18	3.5	5/16"		AA-NP		
ADGTR/L12B-2D36JS		12	12	120	12.28	33	2	18	3.5	5/16"		AA-NP		
ADGTR/L12B-2D36JCB		12	12	140	12.28	33	2	18	3.5	5/16"		-		
ADGTR/L12B-3D36J	DGR 3003Z-6D WDGN3102J	12	12	120	12.25	33	3	18	3.5	5/16"	CSH0414	CS9NQ CS9-2002	AA-NP	LW030
ADGTL12B-3D36JCB		12	12	140	12.25	33	3	18	3.5	5/16"		-		
ADGTR16B-2D24J	WDGN2202J TN6025	16	16	120	16.275	27	2	12	-	1/8"	CSH0412	CS9NQ CS9-2002	-	LW030
ADGTR/L16B-2D26J		16	16	120	16.275	28	2	13	-	1/8"			-	
ADGTL16B-2D26JCB		16	16	140	16.275	28	2	13	-	1/8"			-	
ADGTR16B-2D26JS		16	16	120	16.275	28	2	13	-	1/8"			-	
ADGTR/L16B-2D36JCB		16	16	140	16.275	33	2	18	-	1/8"			-	
ADGTL16B-2D36JF		16	16	120	16.275	33	2	18	-	1/8"			-	
ADGTR16B-2D36JS		16	16	120	16.275	33	2	18	-	1/8"			-	
ADGTL16B-2D36JSCB		16	16	140	16.275	33	2	18	-	1/8"			-	
ADGTR/L16B-3D40J	DGR 3003Z-6D	16	16	120	16.25	35	3	20	-	1/8"	CSH0414	-	-	LW030
ADGTL16B-3D40JS		16	16	120	16.25	35	3	20	-	1/8"		-		
ADGTR/L20B-2D36JS	WDGN2202J TN6025	20	20	125	20.275	33	2	18	-	1/8"	CSH0516	CS9NQ CS9-2002	-	LW040
ADGTR/L20B-3D40J	DGR 3003Z-6D	20	20	125	20.25	35	3	20	-	1/8"			-	
ADGTL20B-3D40JS		20	20	125	20.25	35	3	20	-	1/8"			-	
ADGTR/L20B-3D44JS		20	20	125	20.25	37	3	22	-	1/8"			-	
ADGTR25B-2D36J	WDGN2202J TN6025	25	25	150	25.275	33	2	18	-	1/8"	CSH0516	CS9NQ CS9-2002	-	LW040
ADGTR25B-2D36JS		25	25	150	25.275	33	2	18	-	1/8"			-	
ADGTL25B-3D40J	DGR 3003Z-6D	25	25	150	25.25	35	3	20	-	1/8"			-	
ADGTR25B-3D40JS		25	25	150	25.25	35	3	20	-	1/8"			-	

Grooving Tools 槽刀

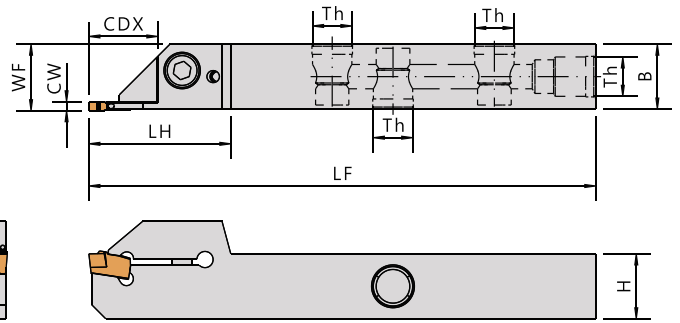
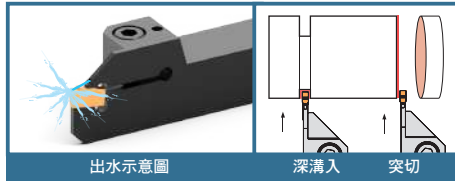
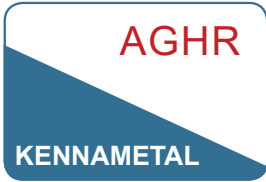

▼Recommended Inserts 建議刀片品牌：KENNAMETAL

Order No.	Insert	Dimensions(mm)								Insert Screw	Coolant plug	Adapter	Wrench
		柄高	柄寬	總長	寬度	頭長	切寬	切深	牙孔				
Right / Left		H	B	LF	WF	LH	CW	CDX	Th				
AGHR/L-1212K02-12	A2022	12	12	125	12.4	30	2	12	5/16"	CSH0514	CS9NN CS9-3003	AA-NP	LW040
AGHR/L-1616K02-12	A2G02	16	16	125	16.4	33	2	12	1/8"		CS9NQ CS9-3003		
AGHR/L-1616K03-16	A2030 A3G03	16	16	125	16.4	37	3	16	1/8"	-	CS9NQ CS9-3003		
AGHR/L-1616K03-20		16	16	125	16.4	41	3	20	1/8"		CS9NQ CS9-3003		
AGHR/L-2525M03-26		25	25	150	25.4	47	3	26	1/8"		CS9NQ CS9-3003		

Grooving Tools 槽刀

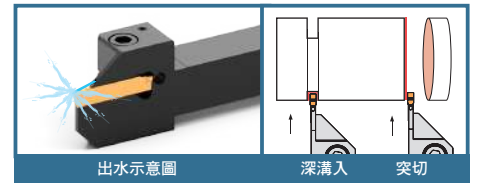

AGNDRM1212JX-211JS

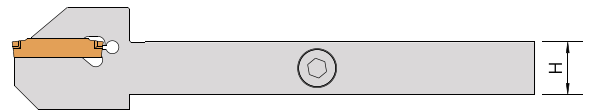
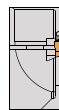
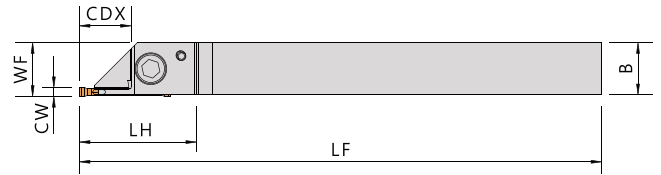

AGNDRM2525M-525

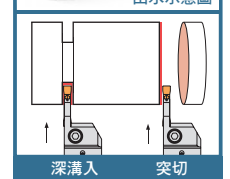
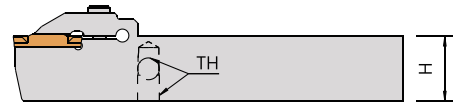
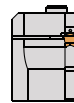
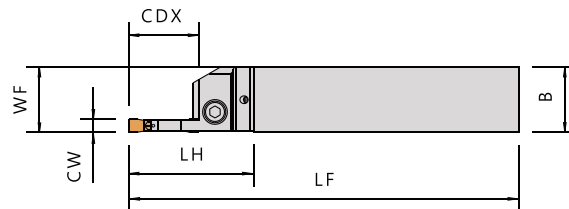

▼ Recommended Inserts 建議刀片品牌 : SUMITOMO

Order No.	Insert	Dimensions(mm)								Insert Screw	Coolant plug	Wrench
		柄高	柄寬	總長	寬度	頭長	切寬	切深	牙孔			
Right / Left		H	B	LF	WF	LH	CW	CDX	Th			
AGNDRM1212JX-211JS	GCMN20	12	12	120	12.35	27	2	11	5/16"	CSH0412	CS9NN CS9-2002	LW030 LW040
AGNDRM1212JX-218JS	GCMN20	12	12	120	12.35	33	2	18	5/16"			
AGNDRM2525M-320	GCMN30	25	25	150	25.25	44.5	3	20	1/8"	CSH0514	CS9NQ CS9-3003	LW040
AGNDRM2525M-525	GCMN50	25	25	150	25.25	48	5	25	1/8"			

Grooving Tools 槽刀

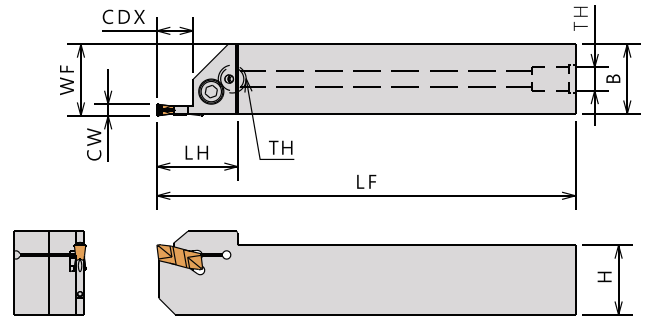
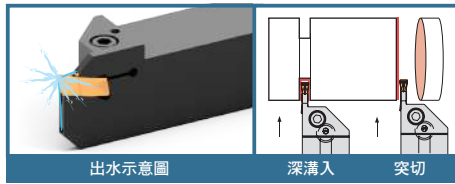

▼Recommended Inserts 建議刀片品牌：ISCAR

Order No.	Insert	Dimensions(mm)									Insert Screw	Coolant plug	Adapter	Wrench
		柄高	柄寬	總長	寬度	頭長	切寬	切深	下巴厚	牙孔				
Right / Left		H	B	LF	WF	LH	CW	CDX	HBH	Th				
AGHSR1212JX03-10R	GIP 3.00-020	12	12	120	12.6	27	3	10	2	5/16"	CSH0512	CS9NN CS9-3003	AA-NP	LW040
AGHSR1616JX03-10R		16	16	120	16.6	26	3	10	2	1/8"				
AGHSR2020K03-10		20	20	125	20.6	27	3	10	-	1/8"				
AGHSR2525M03-12JS		25	25	150	25.6	29	3	12	-	1/8"	CSH0516	CS9NQ CS9-3003		
AGHSR2525M04-12JSWP		GIP 4.00	25	25	150	25.6	29	4	12	-			1/8"	

WP : Multiple coolant direction 上下雙出水

Grooving Tools 槽刀

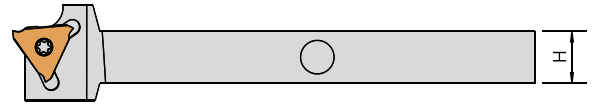
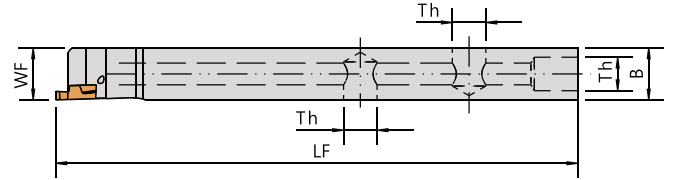

▼Recommended Inserts 建議刀片品牌：SUMITOMO/ACC

Without coolant thru-TGWCR Series 無油孔系列

Order No.	Insert	Dimensions(mm)					Insert Screw	Coolant plug	Adapter	Wrench	
		柄高	柄寬	總長	寬度	牙孔				刀片螺絲	止付螺絲
Right / Left		H	B	LF	WF	Th					
AGWCR1212-3	TGAR3 TGR16	12	12	120	12	5/16"	CS40090	CSPNN CS9-3003	AA-NP	TL-15	LW040
AGWCR1616-3		16	16	120	16	1/8"					

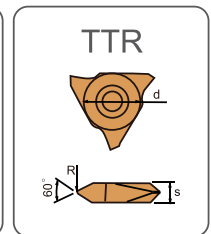
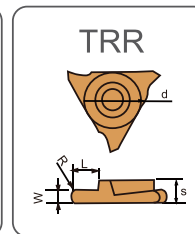
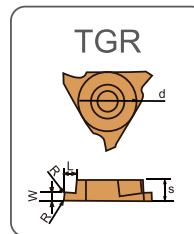
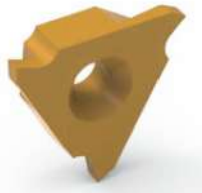

Ordering Code	UA3F2	W	L	R	d	S
TGR16050	*	0.50	1.4	0.00	9.525	3.18
TGR16075	*	0.75	2.5	0.10	9.525	3.18
TGR16095	*	0.95	2.5	0.10	9.525	3.18
TGR16100	*	1.00	2.5	0.10	9.525	3.18
TGR16125	*	1.25	2.5	0.10	9.525	3.18
TGR16135	*	1.35	2.5	0.10	9.525	3.18
TGR16150	*	1.50	2.5	0.20	9.525	3.18
TGR16200	*	2.00	3.0	0.20	9.525	3.18
TGR22100	*	1.00	2.5	0.10	12.70	4.76
TGR22125	*	1.25	2.5	0.20	12.70	4.76
TGR22135	*	1.35	2.5	0.20	12.70	4.76
TGR22145	*	1.45	2.5	0.20	12.70	4.76
TGR22150	*	1.50	3.9	0.20	12.70	4.76
TGR22200	*	2.00	3.9	0.20	12.70	4.76
TGR22250	*	2.50	5.4	0.30	12.70	4.76
TGR22300	*	3.00	5.4	0.30	12.70	4.76

Ordering Code	UA3F2	W	L	R	d	S
TRR22050	*	1.00	2.5	0.50	12.70	4.76
TRR22075	*	1.50	3.9	0.75	12.70	4.76
TRR22100	*	2.00	3.9	1.00	12.70	4.76
TRR22125	*	2.50	5.4	1.25	12.70	4.76
TRR22150	*	3.00	5.4	1.50	12.70	4.76
TRR22175	*	3.50	5.4	1.75	12.70	4.76
TRR22200	*	4.00	5.4	2.00	12.70	4.76

Ordering Code	UA3F2	Pitch (mm)	R	d	S
TTR226001	*	1.0~1.75	0.10	12.70	4.76
TTR226002	*	2.0~2.5	0.20	12.70	4.76

Grooving Tools 槽刀

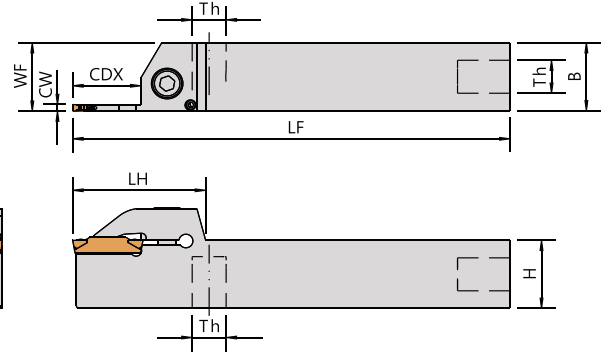
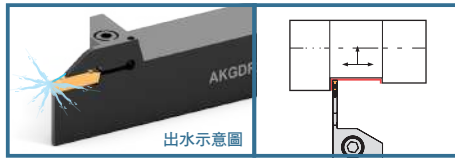

▼Recommended Inserts 建議刀片品牌：KYOCERA

Order No.	Insert	Dimensions(mm)									Insert Screw	Coolant plug	Adapter	Wrench
		柄高	柄寬	總長	寬度	頭長	切寬	切深	下巴厚	牙孔				
Right / Left		H	B	LF	WF	LH	CW	CDX	HBH	Th				
AKGDR1212H-2T13	GDM20	12	12	100	12.15	24	2	13	2	5/16"	CSB0414	CS9NN CS9-2002 CS9-5005	AA-NP	FT-15 LW025 LW040
AKGDR/L1212JX-2T12JF		12	12	120	12.15	24	2	12	2	5/16"	CSR50140	CS9NN CS9-2002 CS9-5005	-	FT-15 LW040
AKGDL1212JX-2T13JF		12	12	120	12.15	25	2	13	2	5/16"	CSR50140	CS9NN CS9-2002 CS9-5005	-	FT-15 LW040
AKGDR1212K-2T18		12	12	125	12.15	30	2	18	2	5/16"	CSB0414	CS9NN CS9-2002 CS9-5005	AA-NP	LW025 LW040
AKGDR1616H-2T13		16	16	100	16.15	33	2	13	4	1/8"	CSH0514	CS9NQ CS9-3003	-	LW040
AKGDR/L1616JX-2T17JF		16	16	120	16.15	29	2	17	-	1/8"	CSR50140	CS9NQ CS9-2002 CS9-6006	-	FT-15 LW040
AKGDR1616K-2T18		16	16	125	16.15	36	2	18	4	1/8"	CSH0514	CS9NQ CS9-3003	-	LW040
AKGDR/L2020K-2T18S		20	20	125	20.15	38	2	18	-	1/8"	CSH0520	CS9NQ CS9-25025	-	LW040
AKGDR2525M-2T18S		25	25	150	25.15	38	2	18	-	1/8"	CSH0520	CS9NQ CS9-25025	-	
AKGDR1212K-3T18		GDM30	12	12	125	12.3	30	3	18	2	5/16"	CSH0520	CS9NN CS9-3003	AA-NP
AKGDR1616K-3T18	16		16	125	16.3	36	3	18	4	1/8"	CSH0520	CS9NQ CS9-3003	-	LW040
AKGDR2020K-3T18	20		20	125	20.3	38	3	18	-	1/8"	CSH0520	CS9NQ CS9-3003	-	LW040
AKGDR2525M-3T13	25		25	150	25.3	33	3	13	-	1/8"	CSH0520	CS9NQ CS9-3003	-	LW040
AKGDR2525M-3T20	25		25	150	25.3	38	3	20	-	1/8"		CS9NQ CS9-3003	-	

Grooving Tools 槽刀

ASLAL-38

ACC

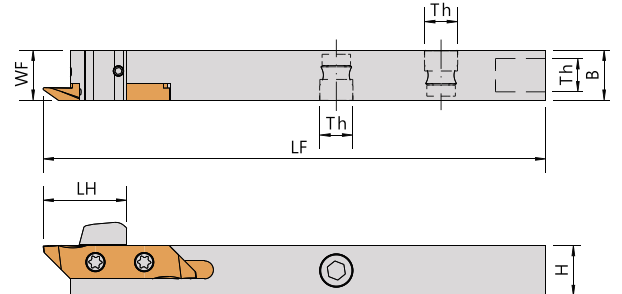
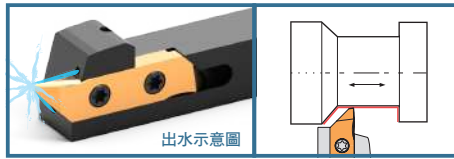

▼ Recommended Inserts 建議刀片品牌：ACC

Order No.	Insert	Dimensions(mm)						Insert Screw	Coolant plug	Adapter	Wrench	
		柄高	柄寬	總長	寬度	頭長	牙孔				轉接頭	板手
Right / Left		H	B	LF	WF	LH	Th					
ASLALR1010JX38	L*R/L38	10	10	120	10	20	5/16"	CS35119S	CS9NN CS9-25025	AA-NP	FT-15	LW040
ASLALR1212JX38		12	12	120	12	20	5/16"					
ASLALR1616JX38		16	16	120	16	20	1/8"					

L#R

槽刀片

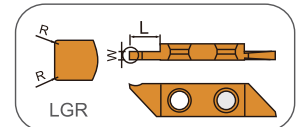
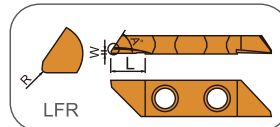
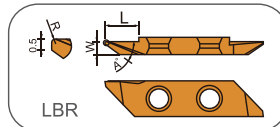

Ordering Code	UN212	W	A°	R	L
LBR382020V	*	2.0	35°	0.2	3.5
LBR383020V	*	3.0	35°	0.2	6.0
LBR384020V	*	4.0	35°	0.2	9.0

Ordering Code	UN212	W	A°	R	L
LFR383500V	*	0.5	35°	0.0	6.5
LFR383502V	*	0.5	35°	0.2	6.5
LFR385500V	*	0.5	55°	0.0	6.5
LFR385502V	*	0.5	55°	0.2	6.5

Ordering Code	UN212	W	R	L
LGR381000U	*	1.0	0.0	2.5
LGR381500U	*	1.5	0.0	5.0
LGR382020U	*	2.0	0.2	6.0
LGR382520U	*	2.5	0.2	8.0
LGR383020U	*	3.0	0.2	8.0

Grooving Tools 槽刀

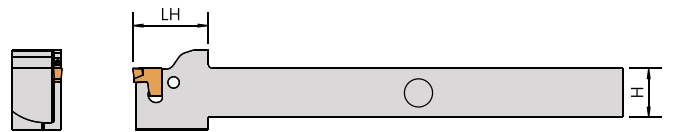
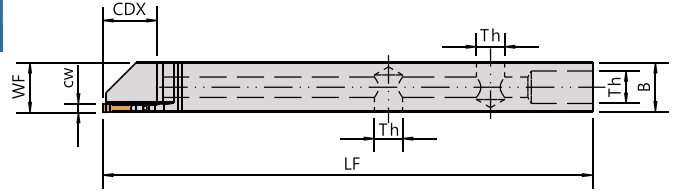
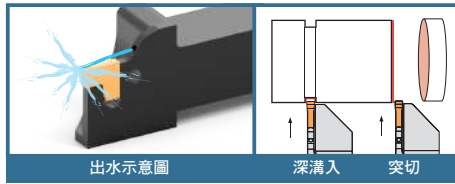

▼Recommended Inserts 建議刀片品牌：ISCAR

Order No.	Insert	Dimensions(mm)								Insert Screw	Coolant plug	Adapter	Wrench
		柄高	柄寬	總長	寬度	頭長	刀寬	切深	牙孔				
Right / Left		H	B	LF	WF	LH	CW	CDX	Th				
ATGTR1212-2J24	TAG-N2J	12	12	110	12.2	18.5	2	12	5/16"	-	CS9NN CS9-3003	AA-NP	LW040

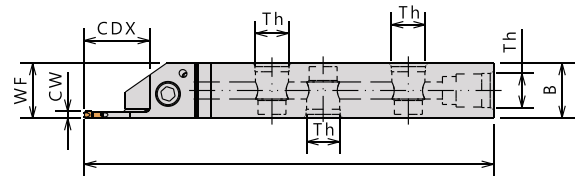
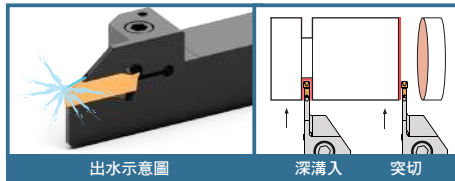

▼Recommended Inserts 建議刀片品牌：ACHTECK

Order No.	Insert	Dimensions(mm)										Insert Screw	Coolant plug	Adapter	Wrench
		柄高	柄寬	總長	寬度	頭長	切寬	切深	下巴厚	牙孔					
Right / Left		H	B	LF	WF	LH	CW	CDX	HBH	Th					
ATSER/L12B-2D24JS	ACD202	12	12	120	12.15	33	2	12	3.5	5/16"	CSH0412	CS9NN CS9-2002	AA-NP	LW030 LW040	
ATSER/L12B-2D36JS		12	12	120	12.15	33	2	18	3.5	5/16"					CS9NN CS9-2002
ATSER/L16B-2D26JS		16	16	120	16.15	33	2	13	-	1/8"		CS9NQ CS9-2002			
ATSER/L16B-2D36JS		16	16	120	16.15	33	2	18	-	1/8"					

Grooving Tools 槽刀

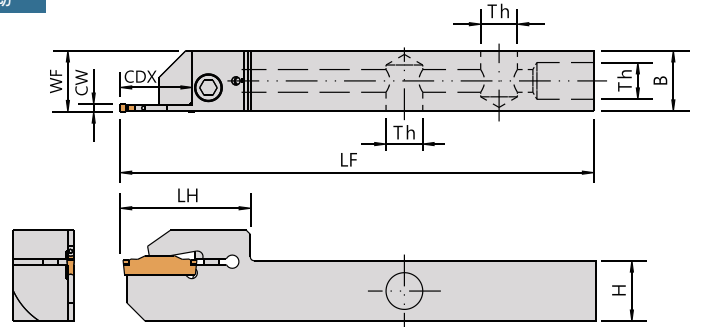
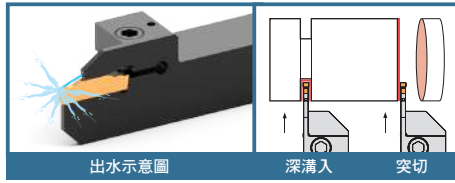

▼Recommended Inserts 建議刀片品牌：TaeguTec

Order No.	Insert	Dimensions(mm)								Insert Screw	Coolant plug	Adapter	Wrench
		柄高	柄寬	總長	寬度	頭長	切寬	切深	牙孔				
Right / Left		H	B	LF	WF	LH	CW	CDX	Th				
ATTER/L12B-2D36JS	TDJ2	12	12	125	12.2	33.6	2	18	5/16"	CSH0414	CS9NN CS9-2002	AA-NP	LW030 LW040
ATTER/L16B-2D36JS		16	16	125	16.2	33.6	2	18	1/8"	CSH0414	CS9NQ CS9-2002	-	

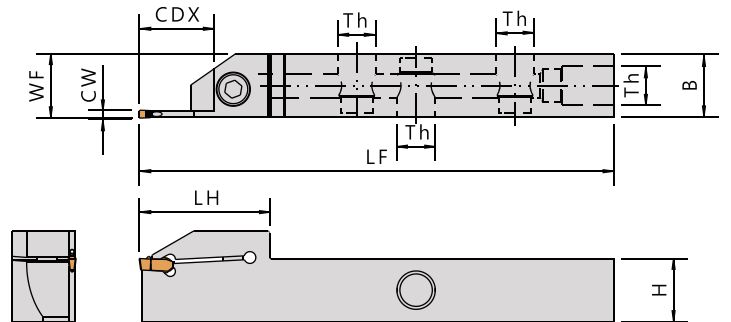
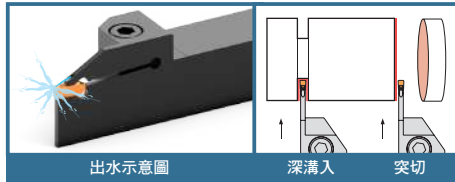

▼Recommended Inserts 建議刀片品牌：WIDIA

Order No.	Insert	Dimensions(mm)								Insert Screw	Coolant plug	Wrench
		柄高	柄寬	總長	寬度	頭長	切寬	切深	牙孔			
Right / Left		H	B	LF	WF	LH	CW	CDX	Th			
AWGCSMR/L16B-2D36JS	WC020M02	16	16	120	16.2	33	2	18	1/8"	CSH0516	CS9NQ CS9-3003	LW040
AWGCSMR25B-2D36J		25	25	150	25.2	33	2	18	1/8"	CSH0516	CS9NQ	

Grooving Tools 槽刀

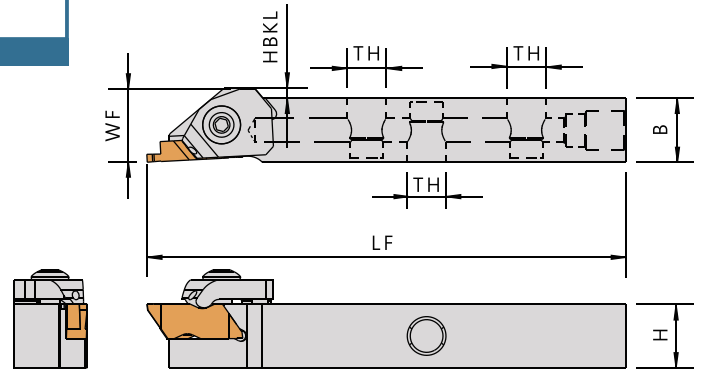
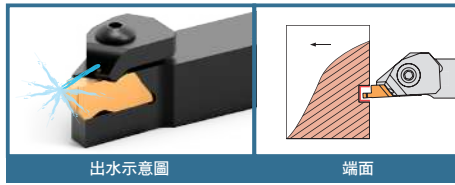

▼Recommended Inserts 建議刀片品牌：KENNAMETAL/WIDIA/ACC



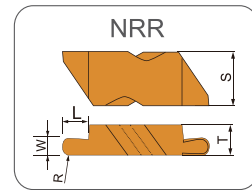
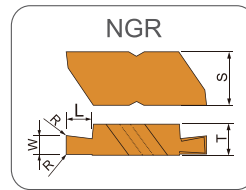
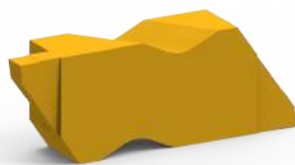

Order No.	Insert	Dimensions(mm)								Clamp	Clamp Screw	O-ring	Coolant plug	Adapter	Wrench
		柄高	柄寬	總長	頭長	切寬	切深	背面長度差	牙孔						
Right / Left		H	B	LF	LH	CW	CDX	HBKL	Th						
AUASR-1212JX2	N**R2 / NG2M	12	12	120	-	2	3.5	-	5/16"	CPK3A-A	CSH3512	WS04	CS9NN	AA-NP	LW025 LW040
AUASR-1616JX3	N**R3 / NG3M	16	16	120	-	3	5.3	2.5	1/8"	CPK1-A	CSB0516	WS04	CS9NQ	-	LW040

Order No.	Insert	Dimensions(mm)								Clamp	Clamp Screw	O-ring	Coolant plug	Adapter	Wrench
		柄高	柄寬	總長	頭長	切寬	切深	背面長度差	牙孔						
Right / Left		H	B	LF	LH	CW	CDX	HBKL	Th						
AUSR/L-2525M3	N**R3 / NG3M	25	25	150	33	3	5.3	-	1/8"	CPK1-U	CSH0516	WS04	CS9NQ	-	LW040



Ordering Code	UN123	W	L	R	T	S
NGR21000	*	1.00	1.3	0.0	3.81	5.56
NGR21500	*	1.50	2.8	0.0	3.81	5.56
NGR22020	*	2.00	2.8	0.2	3.81	5.56
NGR22520	*	2.50	2.8	0.2	3.81	5.56
NGR31500	*	1.50	2.4	0.0	4.95	8.74
NGR32020	*	2.00	2.4	0.2	4.95	8.74
NGR32520	*	2.50	3.8	0.2	4.95	8.74
NGR33020	*	3.00	3.8	0.2	4.95	8.74

Ordering Code	UN123	W	L	R	T	S
NRR210050	*	1.00	1.5	0.50	3.81	5.56
NRR215075	*	1.50	2.5	0.75	3.81	5.56
NRR220100	*	2.00	2.5	1.00	3.81	5.56
NRR225125	*	2.50	2.5	1.25	3.81	5.56
NRR320100	*	2.00	2.0	1.00	4.95	8.74
NRR325125	*	2.50	3.5	1.25	4.95	8.74
NRR330150	*	3.00	3.5	1.50	4.95	8.74
NRR335175	*	3.50	3.5	1.75	4.95	8.74
NRR340200	*	4.00	3.5	2.00	4.95	8.74
NRR345225	*	4.50	3.5	2.25	4.95	8.74

Joint			Coupler		
Exterior	Item No.	Th	Exterior	Item No.	Th
	AA-NP1/8	R1/8-G1/8		AA-NWC1/8	R1/8
	AA-NP1/8L	R1/8-G1/8		AA-NWCP	Rc1/8

Hose			
Exterior	Item No.	牙孔	總長
		Th	LF
	AA-NHS200	G1/8	200
	AA-NHS300		300
	AA-NHS400		400
	AA-NHS500		500
	AA-NHS600		600
	AA-NHS800		800

※NPT=NPTF=美制錐螺紋

※BSPT=PT=R=RC=英制錐螺紋

※BSPP=BSP=PF=G=英制直螺紋

2023 ▶ 2024

OIL HOLE CUTTING TOOLS CATALOG



明祿工業股份有限公司
MAROX TOOLS INDUSTRIAL CO., LTD.



加入LINE@客服
ID : @glt5254f



搜尋明祿官網
查看更多規格

- 📍 411 台灣台中市太平區新仁路一段22巷65號
No.65, Lane 22, sec. 1, Hsinjen Rd., Taiping Dist., Taichung City, Taiwan
- ☎ 886-4-22780167~8 ⚙ 統編:52384098
- 📞 886-4-22780111 ✉ service@marox.com.tw

VER.2307