

## SPECIAL PURPOSE VISES: VISES FOR 5-SIDE MACHINING & TURNING CENTERS

**CORNER** Most kindly design to considered every tiny point.



**High strength. High accuracy.**

— 17 —

### ISO-9001:2008

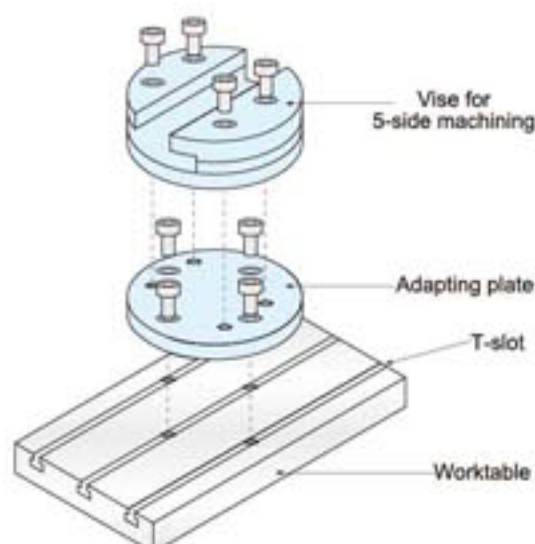
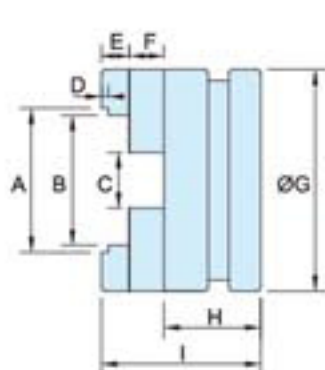
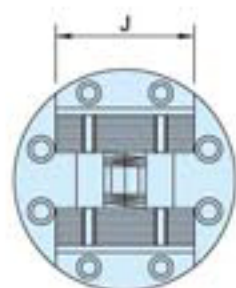

MODEL	A	B	C	D	E	F	G	H	I	J
TMV-100	105	95	40	5	20	25	160	70	115	100
TMV-130	135	125	50	5	20	25	210	80	125	130
TMV-160	165	155	60	5	25	25	250	90	140	160

### PATENT NUMBER 372760

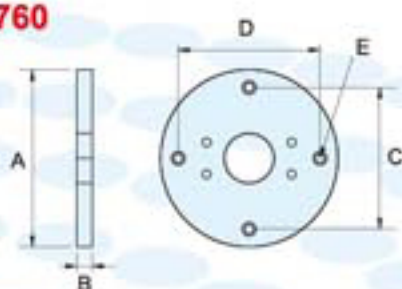

MODEL	A	B	C	D	E
TMV-102	240	22	100	100	M12
TMV-132	250	22	100	100	M12
TMV-162	250	22	100	100	M12



### A good solution for clamping on both turning centres and 5-axis milling machines.

- For quick & easy work piece clamping on turning centres or for 5-axis machining on machine centres. Round-shaped style occupies less space and reduces interference.
- Available are different styles of vise jaws for different machining needs. The TMV vises come with different jaw width of 100mm, 130mm, 160mm and 200mm.

— 18 —