

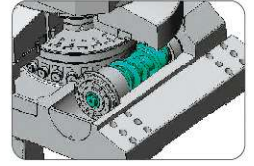

Horizontal ROTARY TABLE

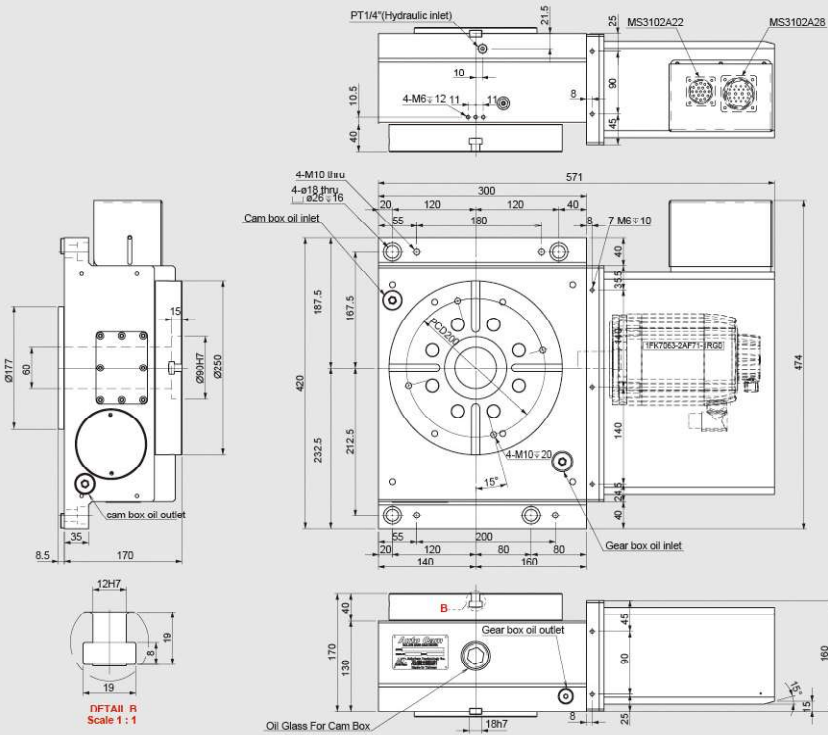

CNC-B軸滾子凸輪機構
B axis-Roller CAM Driver mechanism



AT250H	
項目 Code No.	規格
工作盤直徑 Table diameter	mm Ø250
工作盤面高 Table height	mm 170
基準孔 Guide hole	mm Ø90H7
貫穿孔 Spindle hole	mm Ø60
T型溝 T slot width	mm 12H7
基準定位鍵 Guide block width	mm 15h7
伺服馬達 Servo motor	MELDAS 1FK7063
總減速比 Gear ratio	1/60
工作盤最高迴轉速 Table max. RPM	50
容許切削扭力 Output rated torque	kg·m 25
分割精度 Indexing accuracy	sec 20
重複精度 Repeatability	sec 4
製品質量 Weight	kg 95

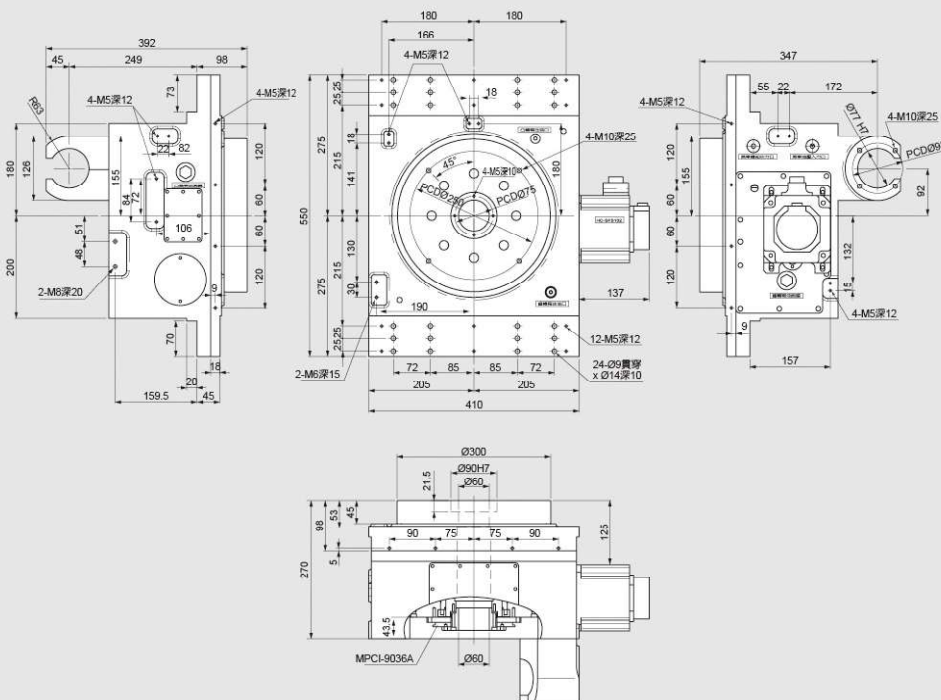

AT300H	
項目 Code No.	規格
工作盤直徑 Table diameter	mm Ø300
基準孔 Guide hole	mm Ø90H7
貫穿孔 Spindle hole	mm Ø60
伺服馬達 Servo motor	FANUC α4/400U MELDAS HC-SFS102
總減速比 Gear ratio	1/60
工作盤最高迴轉速 Table max. RPM	50
最小設定單位 Min. increment	Degree 0.001°
容許切削扭力 Output rated torque	kg·m 24
分割精度 Indexing accuracy	sec 20
重複精度 Repeatability	sec 4
製品質量 Weight	kg 150
選配功能	鎖緊動力源 Clamp system 油壓 H 鎖緊壓力 Hydraulic pressure Mpa 2.0 鎖緊扭力 Output torque at brake kg·m 150 光學尺 Angular encoder (選配 Option) MPC1-9036A

Horizontal ROTARY TABLE



AT320H		
項目	單位	規格
工作盤直徑	mm	Ø320
盤面高	mm	257
基準孔	mm	Ø120H7
貫穿孔	mm	Ø110
伺服馬達		≈ 12is / 4000(S) A068-2238-B100
總減速比		75
最高迴轉數	RPM	40
R/C額定動定格	kg · m	98.9
制動力源		油壓
制動壓力	kg/cm ²	20
制動扭矩	kg · m	150
分割精度	sec	20
重複精度	sec	4
光學尺	海德漢	RCN8590F 中心通孔Ø60
光學尺精度		± 1"
製品質量	kg	220

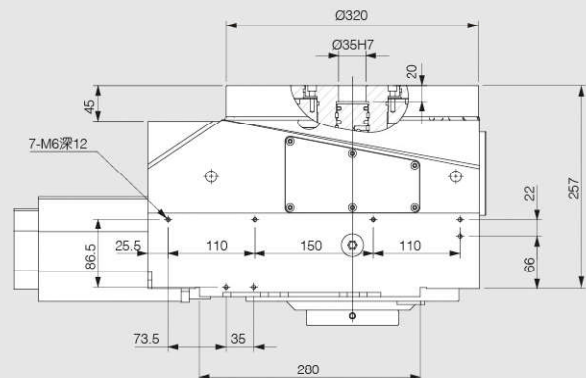
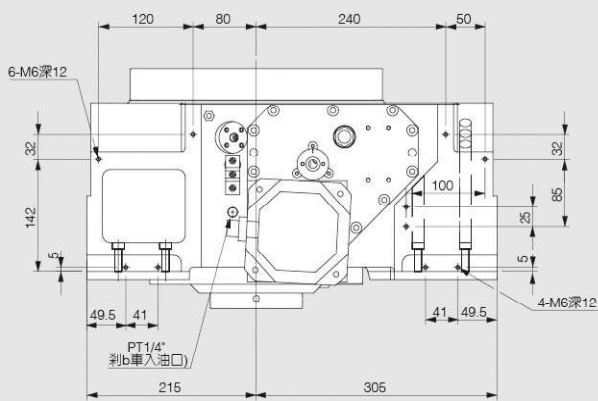
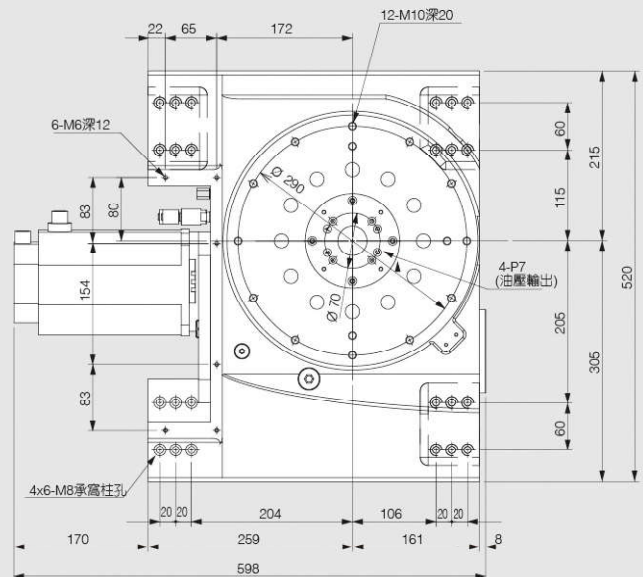

AT400H

項目 Code No.	規格
工作盤直徑 Table diameter	mm Ø400
工作盤面高 Table height	mm 270
基準孔 Guide hole	mm Ø15117
T型溝 T slot width	mm 14H7
基準定位塊 Guide block width	mm 10h7
最大工件負載 Max. load	kg 500
容許負載慣量 Allowable load	kg-m ² 4.5
伺服馬達 Servo motor	α12/3000i
馬達轉速 Motor Speed	RPM 3000
總減速比 Gear ratio	1:90
工作盤最高迴轉速 Table max.	RPM 33.3
容許切削扭力 Output rated torque	kg-m 88
鎖緊動力源 Clamp system	油壓 H
鎖緊壓力 Hydraulic pressure	kg/cm ² 30
鎖緊扭力 Output torque at brake	kg-m 180
最小設定單位 Min. increment	Degree 0.001
分割精度 Indexing accuracy	sec 15
重複精度 Repeatability	sec 4
製品質量 Weight	kg 340

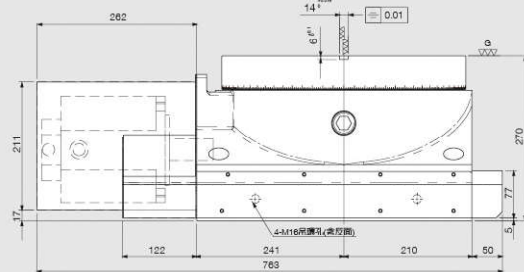
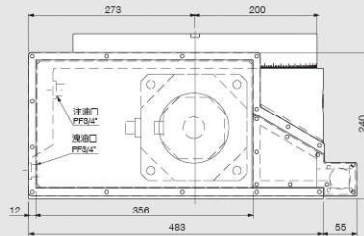
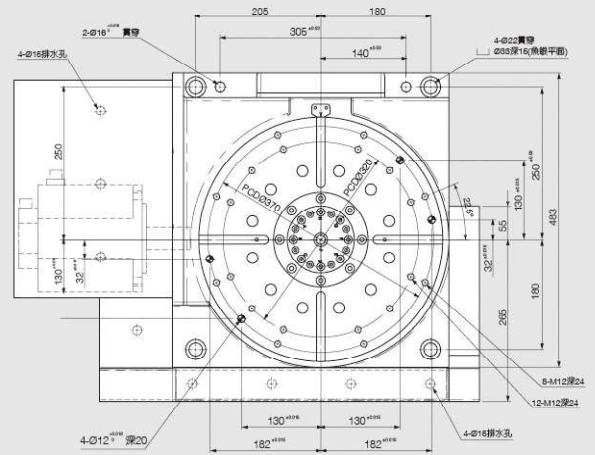

AT630H

項目 Code No.	規格
工作台尺寸 Table size	mm 630X630
工作台高度 Table height	mm 300
伺服馬達 Servo motor	FANUC α22/3000i
	MELDAS HG-453S
總減速比 Gear ratio	1/120
工作盤最高迴轉速 Table max.	RPM 25
最小設定單位 Min. increment	Degree 0.001
容許切削扭力 Output rated torque	kg-m 332
鎖緊動力源 Clamp system	油壓 H
鎖緊壓力 Hydraulic pressure	Mpa 3.5
鎖緊扭力 Output torque at brake	kg-m 350
分割精度 Indexing accuracy	sec 30
重複精度 Repeatability	sec 4
容許載重 Allowable work weight	kg 1200
製品質量 Weight	kg 900

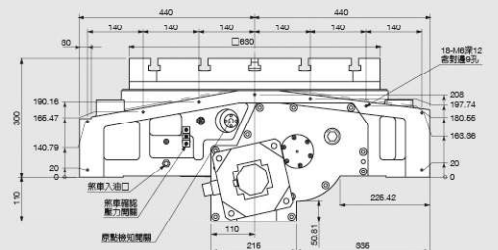
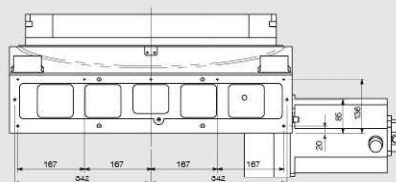
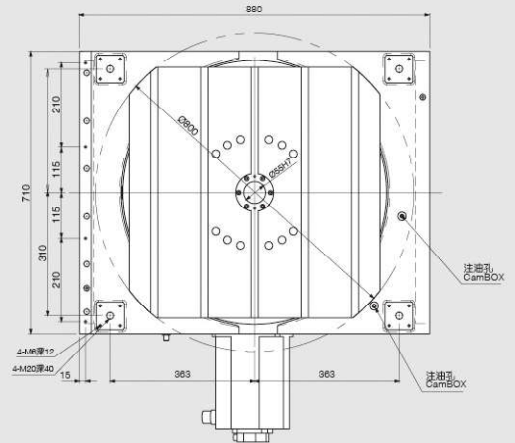

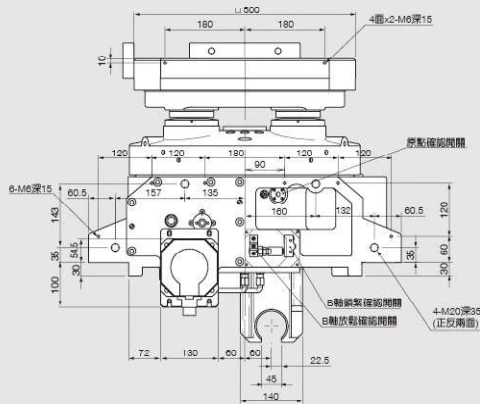
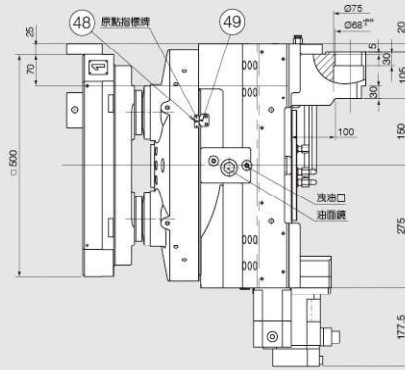
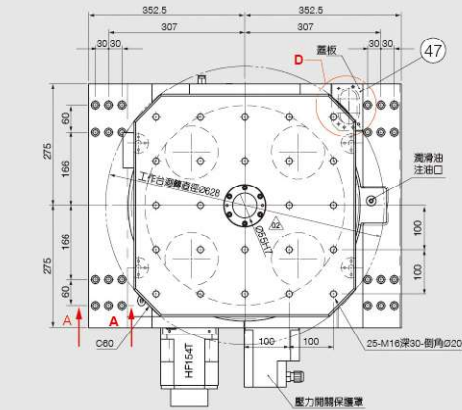

剖面圖 A-A

ATH500		規格
項目 Code No.		500X500
工作台面尺寸 Table size	mm	500X500
工作台面高度 Table height	mm	460
基準孔徑 Guide hole	mm	Ø55H7
伺服馬達 Servo motor	FANUC MELDAS	α12/4000is(T) HG154T
總減速比 Gear ratio		1/90
工作檯最高迴轉速 Table max.	RPM	44.4
最小設定單位 Min. increment	Degree	0.001
容許切削扭力 Output rated torque	kg-m	88
B軸鎖緊動力源 B-axis clamp system		油壓 H
鎖緊壓力 Hydraulic pressure	Mpa	3.5
鎖緊扭力 Output torque at brake	kg-m	500
分割精度 Indexing accuracy	sec	30
重複精度 Repeatability	sec	4
錐座夾緊力 Clamp force of taper-cone	kgf	4200
容許載重 Allowable work weight	kg	600
製品質量 Weight	kg	600

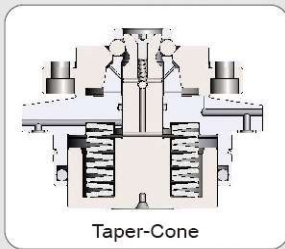

Taper-Cone

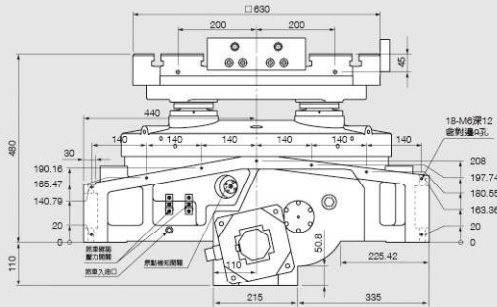
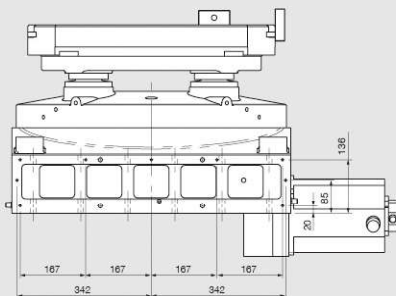
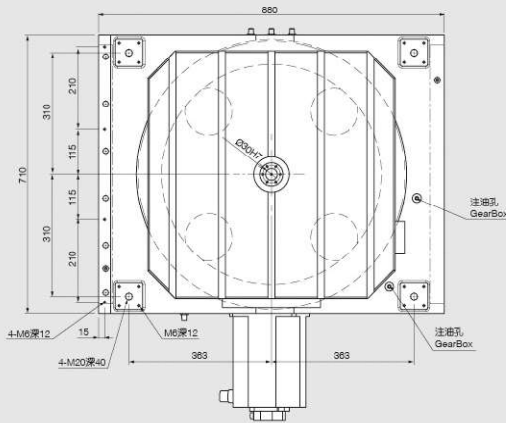

ATH630		規格
項目 Code No.		630x630
工作台面尺寸 Table size	mm	630x630
工作台面高度 Table height	mm	480
工作台面基準孔徑 Guide hole	mm	Ø30H7
T型溝 T slot width	mm	18H7
伺服馬達 Servo motor	FANUC MELDAS	α22i IIG453S
總減速比 Gear ratio		1/120
工作檯最高迴轉速 Table max.	RPM	25
最小設定單位 Min. increment	Degree	0.001
容許切削扭力 Output rated torque	kg-m	215
鎖緊動力源 Clamp system		油壓 H
油壓壓力 Hydraulic pressure	Mpa	3.5
鎖緊扭力 Output torque at brake	kg-m	350
錐座夾緊力 Clamp force of taper-cone	kgf	4200
容許載重 Allowable work weight	kg	1200
分割精度 Indexing accuracy	sec	30
重複精度 Repeatability	sec	4
製品質量 Weight	kg	1400
光學尺規格(選配) Angular encoder		RCN223
分割精度 Indexing accuracy	sec	±5