



DR

3-jaw draw down power chuck

Draw down power chuck feature of radial clamping will lead to almost no work piece uplifting displacement; for machining casting and forging part:

1. For the clamped work-piece is oppressed to the surface, chucks are suitable for heavy machining.
2. Chuck Actuators with cylindrical structure are durable and ensures high clamping repeatability.
3. Accurate self-centering and pull back features are adequate or precise length control machining requirements.

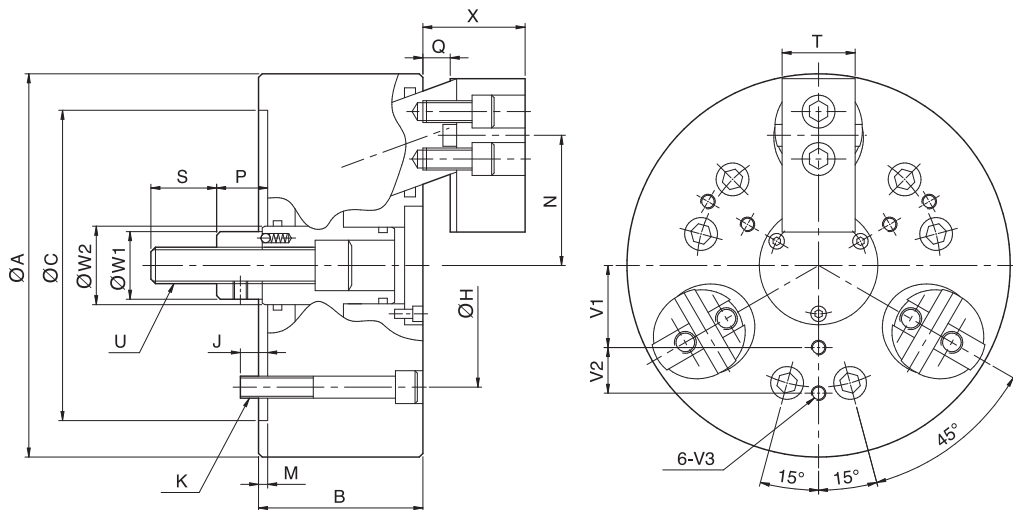

UNIT : mm

SPEC Model	Plunger Stroke (mm)	Jaw Stroke (In Dia.) (mm)	Max. Pull Force kN(kgf)	Max. Gripping Force kN(kgf)	Max. Operating Pressure MPa(kgf / cm ²)	Max. Speed (r.p.m.)	Weight (kg)	Moment Of Inertia I (kg · m ²)	Matching Cylinder	Matching Soft Jaw	Gripping O. D. Range (mm)
DR-06	10	7.2	15(1530)	25(2549)	2.1(21.4)	3500	15	0.05	MS105C	DR-06	Ø35-Ø165
DR-08	10	7.2	25(2549)	45(4589)	2.5(25.5)	3000	25	0.14	MS125C	DR-08	Ø40-Ø210
DR-10	16	11.6	35(3569)	60(6118)	3.3(34)	2500	46	0.374	MS125C	DR-10	Ø50-Ø254
DR-10D	16	11.6	35(3569)	60(6118)	3.3(34)	2500	46.1	0.376	MS125C	DR-10	Ø54-Ø254
DR-12	16	11.6	44(4487)	71(7240)	3(30.6)	2000	76	0.88	MS150C	DR-12	Ø50-Ø304

DIM Model	A	B	C	H	J	K	M	N max.	N min.	P max.	P min.	Q max.	Q min.	S	T	U	W1	W2	X max.	X min.	V1	V2	V3
DR-06	165	85	140	104.78	16	6xM10	5	58	54.4	33	23	14	4	36	35	M16x2.0	32	33.5	45	35	35	20	M6x12
DR-08	210	90	170	133.35	15	6xM12	5	71.3	67.7	38	28	15	5	36	40	M20x2.5	37	42	56	46	45	25	M8x16
DR-10	254	110	220	171.45	23	6xM16	5	85.4	79.6	48	32	20	4	46	50	M24x3.0	50	60	66	50	55	30	M8x16
DR-10D	254	110	220	171.45	23	6xM16	5	87.8	82	48	32	22.6	6.6	46	50	M24x3.0	50	60	68.6	52.6	55	30	M8x16
DR-12	304	125	220	171.45	23	6xM16	5	102.9	97.1	47	31	21.5	5.5	50	60	M27x3.0	52	60	72.5	56.5	100	35	M12x18