

## CT1 | 2 Spindles 1 Turret

### Y-Axis Turret 76mm Built-in Spindle Double Spindle Versatility

- The CT1's double spindle design allows for the cutting of complex parts in a single setup, and coupled with a 16-station turret.
- When the Y-Axis turret is in the upper position, it can complete machining on parts in the main or sub spindle. In addition, tools can be placed facing either the main or sub spindle.
- The special structural design uses a 90° angle for the turret carriage so you maintain superb rigidity and stability in machining. Additionally, this allows you to use a simpler controller specification, reducing programming complexity and saving you money at the same time.
- The servo turrets are designed and built by CC Machinery especially for the CT series. This ensures maximum accuracy during machining, along with super fine finishes.



# CT1

## Machine Layout

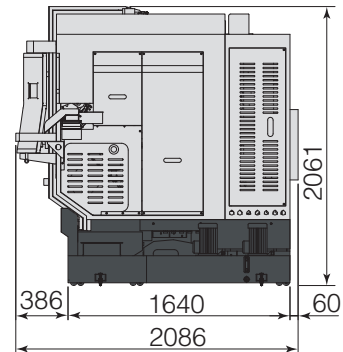
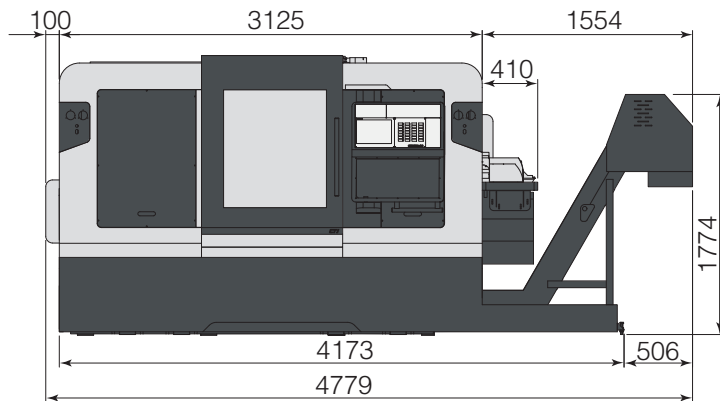

Unit: mm

## Specifications

Model		CT1	
Control Unit	Controller	MITSUBISHI	FANUC
Capacity	Max. Turning Dia.	Ø325 mm	
	Standard Turning Dia.	Ø210 mm	
	Max. Turning Length	560mm	
Axes Specification	X1/Y1/Z1-Axis Travel	225 mm/±50 mm/636 mm	
	X1/Y1/Z1-Axis Motor	2.2kW	2.7kW
	X1/Y1/Z1-Axis Rapid Travel Speed	16/6/40 m/min	
	B-Axis Travel	690.5 mm	
	B-Axis Motor	2.2kW	2.7kW
	B-Axis Rapid Travel Speed	40 m/min	
	Min. Input Unit	0.001 mm	
	Max. Bar Feeding Dia.	Ø76 mm	
Spindle	Spindle Motor	15/22kW	18/22kW
	Max. Spindle Speed	4000 rpm	
	Spindle Nose	A2-6	
	Chuck Size	8"	
Sub Spindle	Max. Bar Feeding Dia.	Ø65 mm	
	Spindle Motor	7.5/11 kW	18/22kW
	Max. Sub Spindle Speed	4000 rpm	
	Spindle Nose	A2-6	
L, R, C	Chuck Size	8"	
	Min. Moving Unit	0.001°	
	C-Axis Rapid Travel Rate	600 min <sup>-1</sup>	
Live Tooling Turret	O.D Turning Tool Size	□25 mm	
	I.D Turning Tool Size	Ø25 mm	
	Rotating Mode	Single Tool Transmission	
	Live Tooling rpm	60~6000 min <sup>-1</sup>	
	Live Tooling Motor	3.7/5.5kW	4.5kW
	Collet Size	ERØ32	
	Tool Holder & Tool Size	BMT65	
Hydraulic	Hydraulic Motor	5HP / 3.7kW	
	Spindle Coolant Pump	1HP / 0.75kW	
Coolant Pump	Turret Coolant Motor	1HP / 0.75kW	
	Chip Flush Pump	1HP / 0.75kW	
	Sub Spindle Internal Coolant Pump	1HP / 0.75kW	
	Tank Capacity	45 L	
Machine	Hydraulic Tank	45 L	
	Coolant Tank	325 L	
	Power	220V/77KVA	220V/90KVA
	Machine Size (LxWxH) (includes chip conveyor)	4779 x 2086 x 2061 mm	
	Machine N.W. (includes chip conveyor)	8000 kg	

\* Design and specs subject to change without notice.

\* M: Mitsubishi, F: Fanuc

