



INNGRIT.COM.TW



T +886-6-2430253 F +886-6-2421869  
www.inngrit.com.tw  
inngritzps@gmail.com  
sales00@inngrit.com.tw  
709台灣台南市安南區安新五路1號



**TAIWAN**  
**EXCELLENCE 2024**

*Everyday Excellence*



## CONTENTS

INNGRIT Smart Machining Solutions	03
Zero Point System	05
Pitch 52 Plates	07
Pitch 52 Adaptor Plates	12
Pitch 52 Ultra Thin Plates	13
Pitch 52 Ultra Thin Adaptor Plates	14
Pitch 96 Plates	16
Pitch 96 Multi Plates	23
L Shape Clamps	27
Clamping Studs & CLAMPING STUDS	31





## EXCITING TIMES AHEAD

Over the last three years there have been tremendous growth and movement at INNGRIT, with the completion of our new production facility and headquarter, in order to meet the demand in INNGRIT Zero Point chucks and plates, thanks to all of our customers and partners for making this journey possible.

We are excited to present to you with this catalogue, our new INNGRIT Zero Point chucks and plates, which will offer even more flexibility and possibility to the existing INNGRIT Zero Point chucks and plates. Our Ultra Thin Zero Plates are probably the thinnest in the world.

Along with the new line we continue to explore and establish more smart tooling and machining solutions in automation and intelligent manufacturing, in order to create more value and support for you, our dear valued customers and partners.

HSU-PIN CHUANG  
CEO







## **AUTOMATED SMART MACHINING SOLUTIONS**

INNGRIT Zero Point chucks and plates are just the start of what INNGRIT is able to offer for your Industry 4.0 machine and tooling workflow.

Our INNGRIT Smart Machining Solutions team offers customized automated intelligent manufacturing systems that incorporates INNGRIT Zero Point chucks and plates, offering our customers and partners reliable turnkey solutions for well designed and cost-effective time saving systems.

Contact us for more details on how to deploy our systems and machining know-how to work for you.

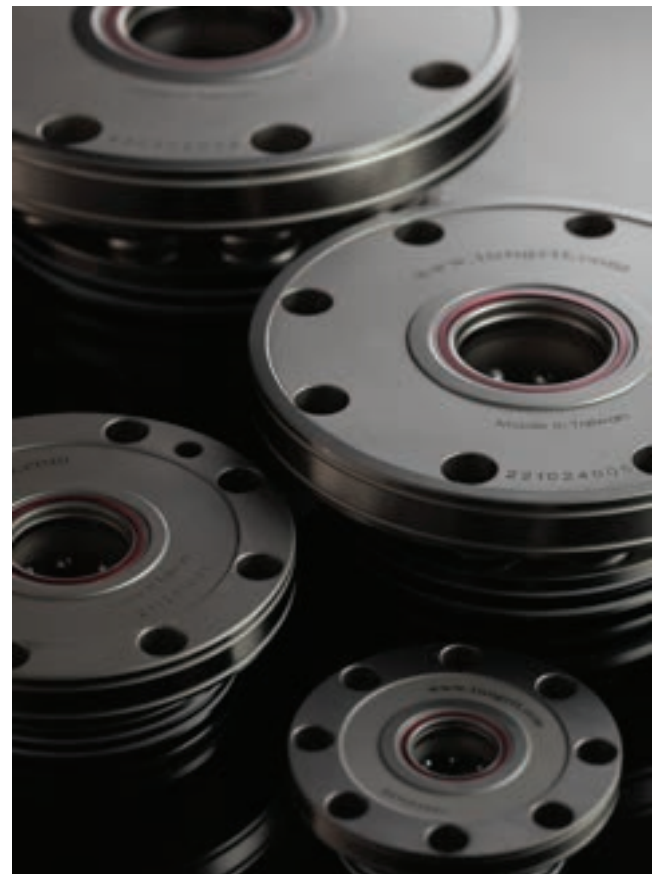



INTRODUCING  
**INNGRIT**  
**ZERO POINT PLATES**

PROBABLY THE THINNEST IN THE WORLD



INNGRIT



# ZERO POINT PLATES

Servicing as an intermediate between machining table and the clamped tooling work, INNGRIT Zero Point chucks and plates offers a quick, reliable way to switch up what is on the machine table, with an unbelievably high degree of precision.

The system is simple, flexible and highly adaptable and expandable. Through INNGRIT Smart Machining Solutions, the whole process can also be automated. If one of our standard products don't fit your needs, customized configurations are also possible.



## SIMPLE IS BEST

Simple may be best, but it isn't always easy. With INNGRIT Zero Point chucks and plates, you have a mechanical zero-point system which is robust and precise, achieving a staggering  $<0.005$  mm repeat accuracy, along with clamping force of 2,000KG (for Oil) and 1,000KG (for Air).

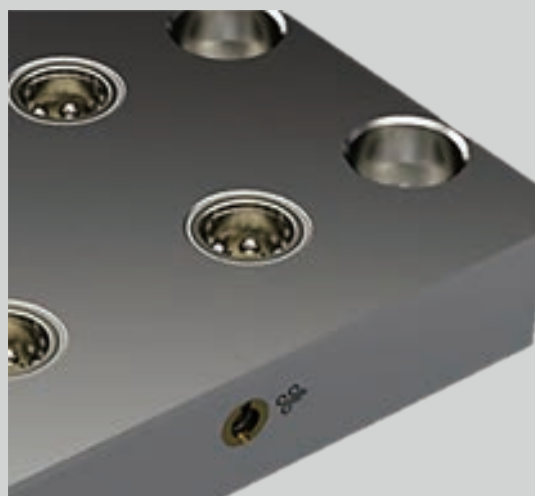

## PATENTED "AIR" OPTION

Our special patented AIR editions feature an Air Blow-out Cleaning/Airflow circuit allowing for additional efficiency of operation which boasting productivity and safety.



## BEAUTIFULLY ENGINEERED

For the INNGRIT Zero Point team, precision is only the beginning. Each part of our Zero Point chucks and plates are made to exacting standards using materials carefully chosen. For us, each curve and line of the Zero Point is a carefully crafted mechanical artworks, whose beauty is realized when it is put to service day in and day-out with high degree of reliability.

# INNGRIT 52 ROUND PLATE WITHOUT MOUNTING BORES

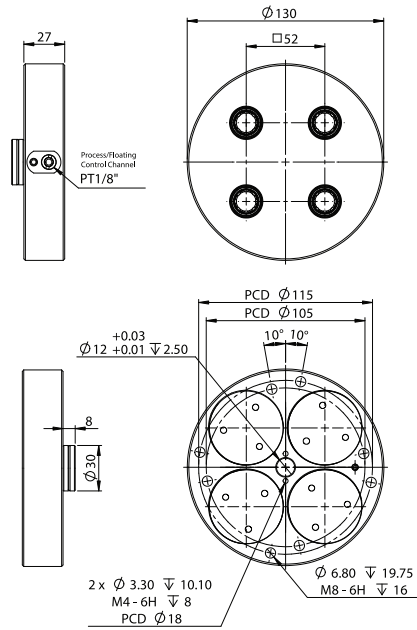

ITEM #	INN02519	AIR CLAMPING FORCE	Max. 1,000 KG	QUICK LOCK	YES
AIR TORQUE	Max. 35~40KG	OIL CLAMPING FORCE	Max. 2,000 KG	DIMENSIONS	Ø130x27mm(pitch52)
OIL TORQUE	Max. 40KG	CLAMPING STUD	12mm match INN0295	WELGHT	2.22KG

# INNGRIT 52 ROUND PLATE (AIR) WITHOUT MOUNTING BORES

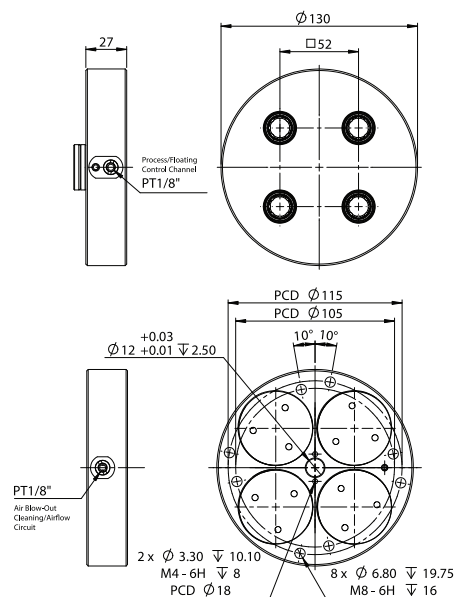

ITEM #	INN02479	AIR CLAMPING FORCE	Max. 1,000 KG	QUICK LOCK	YES
AIR TORQUE	Max. 5~7KG	OIL CLAMPING FORCE	Max. 2,000 KG	DIMENSIONS	Ø130x27mm(pitch52)
OIL TORQUE	Max. 40KG	CLAMPING STUD	12mm match INN0295	WELGHT	2.22KG

# INNGRIT 52 ROUND PLATE WITHOUT MOUNTING BORES

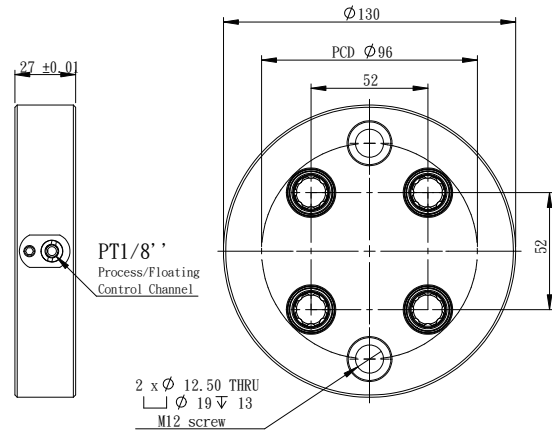

ITEM #	INN02518	AIR CLAMPING FORCE	Max. 1,000 KG	QUICK LOCK	YES
AIR TORQUE	Max. 35~40KG	OIL CLAMPING FORCE	Max. 2,000 KG	DIMENSIONS	Ø130x27mm(pitch52)
OIL TORQUE	Max. 40KG	CLAMPING STUD	12mm match INN0295	WELGHT	2.02KG

# INNGRIT 52 ROUND PLATE (AIR) WITHOUT MOUNTING BORES

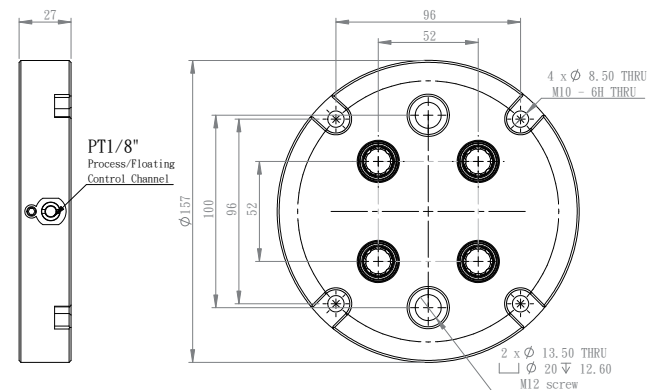

ITEM #	INN02621	AIR CLAMPING FORCE	Max. 1,000 KG	QUICK LOCK	YES
AIR TORQUE	Max. 5~7KG	OIL CLAMPING FORCE	Max. 2,000 KG	DIMENSIONS	Ø130x27mm(pitch52)
OIL TORQUE	Max. 40KG	CLAMPING STUD	12mm match INN0295	WELGHT	2.02KG



## INNGRIT 52 ROUND PLATE WITHOUT MOUNTING BORES

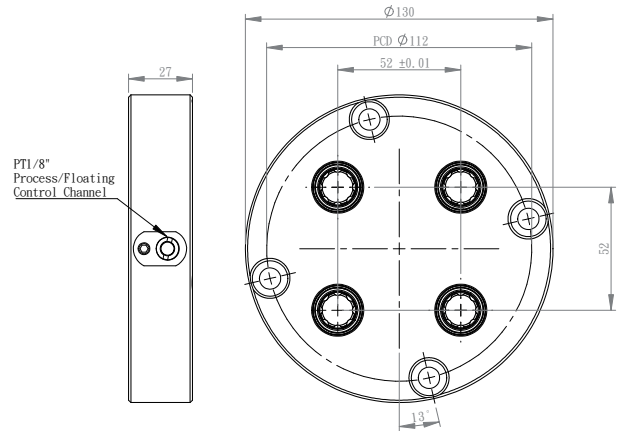
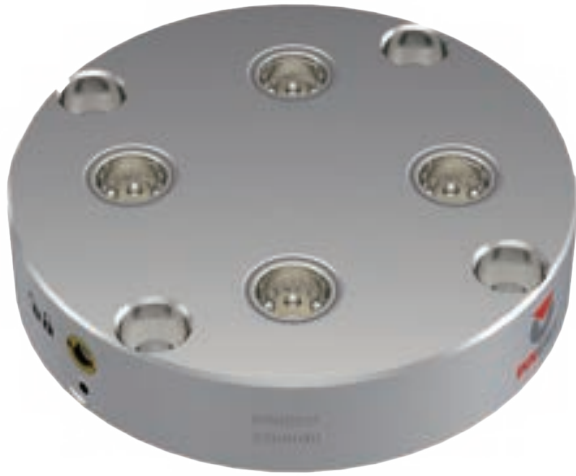

ITEM #	INN02535	AIR CLAMPING FORCE	Max. 1,000 KG	QUICK LOCK	YES
AIR TORQUE	Max. 35~40KG	OIL CLAMPING FORCE	Max. 2,000 KG	DIMENSIONS	Ø130x27mm(pitch52)
OIL TORQUE	Max. 40KG	CLAMPING STUD	12mm match INN0295	WELGHT	2.22KG

## INNGRIT 52 ROUND PLATE (AIR) WITHOUT MOUNTING BORES

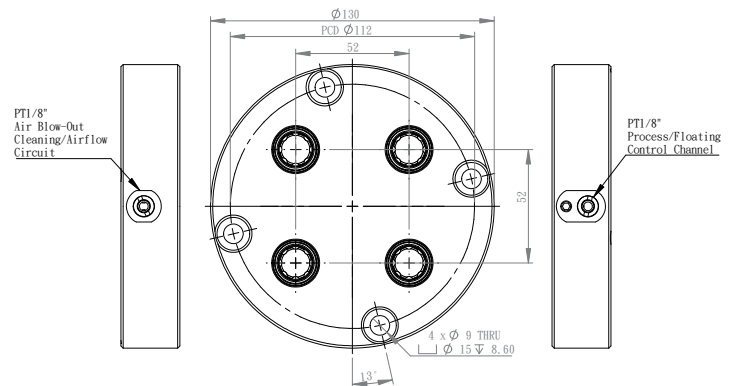

ITEM #	INN02515	AIR CLAMPING FORCE	Max. 1,000 KG	QUICK LOCK	YES
AIR TORQUE	Max. 5~7KG	OIL CLAMPING FORCE	Max. 2,000 KG	DIMENSIONS	Ø130x27mm(pitch52)
OIL TORQUE	Max. 40KG	CLAMPING STUD	12mm match INN0295	WELGHT	2.22KG

# INNGRIT 52 ROUND PLATE

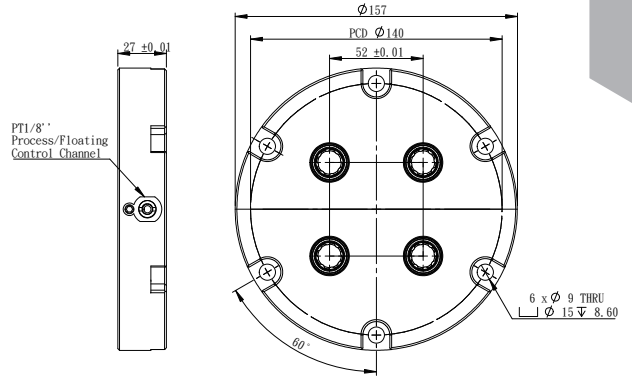

ITEM #	INN02644	AIR CLAMPING FORCE	Max. 1,000 KG	QUICK LOCK	YES
AIR TORQUE	Max. 35~40KG	OIL CLAMPING FORCE	Max. 2,000 KG	DIMENSIONS	Ø157x27mm(pitch52)
OIL TORQUE	Max. 40KG	CLAMPING STUD	12mm match INN0295	WELGHT	3.30KG

# INNGRIT 52 ROUND PLATE (AIR)

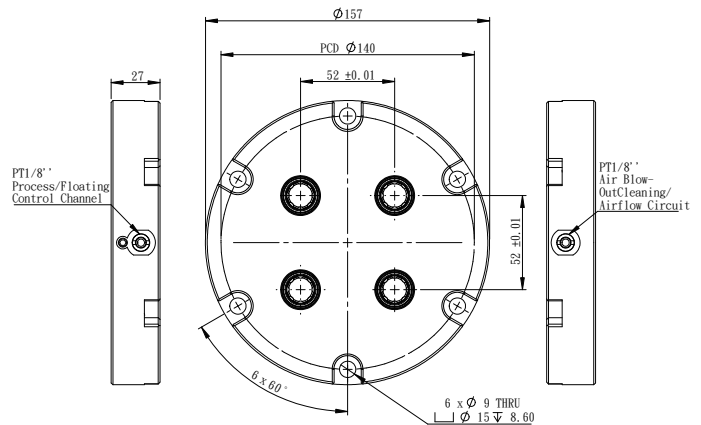

ITEM #	INN02643	AIR CLAMPING FORCE	Max. 1,000 KG	QUICK LOCK	YES
AIR TORQUE	Max. 5~7KG	OIL CLAMPING FORCE	Max. 2,000 KG	DIMENSIONS	Ø157x27mm(pitch52)
OIL TORQUE	Max. 40KG	CLAMPING STUD	12mm match INN0295	WELGHT	3.30KG

# INNGRIT 52 ROUND PLATE

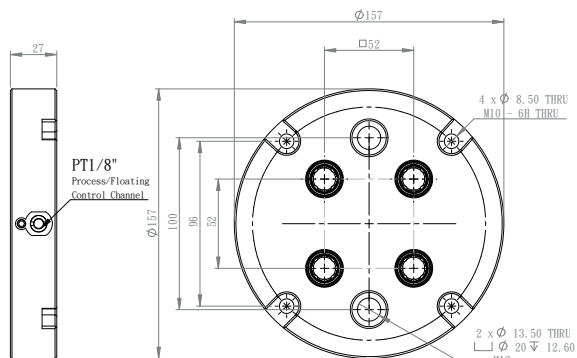

ITEM #	INN02521	AIR CLAMPING FORCE	Max. 1,000 KG	QUICK LOCK	YES
AIR TORQUE	Max. 35~40KG	OIL CLAMPING FORCE	Max. 2,000 KG	DIMENSIONS	$\phi 157 \times 27$ mm(pitch52)
OIL TORQUE	Max. 40KG	CLAMPING STUD	12mm match INN0295	WELGHT	3.32KG

# INNGRIT 52 ROUND PLATE (AIR)

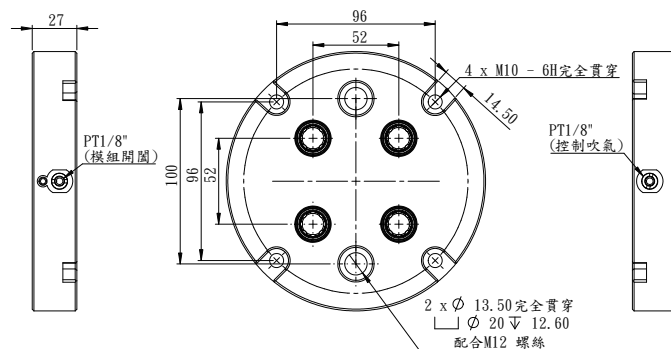

ITEM #	INN02481	AIR CLAMPING FORCE	Max. 1,000 KG	QUICK LOCK	YES
AIR TORQUE	Max. 5~7KG	OIL CLAMPING FORCE	Max. 2,000 KG	DIMENSIONS	$\phi 157 \times 27$ mm(pitch52)
OIL TORQUE	Max. 40KG	CLAMPING STUD	12mm match INN0295	WELGHT	3.32KG



# INNGRIT 52 ROUND PLATE

FROM PITCH 96

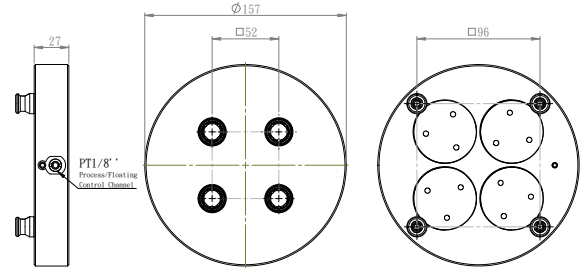

ITEM #	INN02532	AIR CLAMPING FORCE	Max. 1,000 KG	QUICK LOCK	YES
AIR TORQUE	Max. 35~40KG	OIL CLAMPING FORCE	Max. 2,000 KG	DIMENSIONS	Ø157x27mm(pitch 96 to pitch 52)
OIL TORQUE	Max. 40KG	CLAMPING STUD	12mm match INN0295	WELGHT	3.56KG

# INNGRIT 52 ROUND PLATE (AIR)

FROM PITCH 96

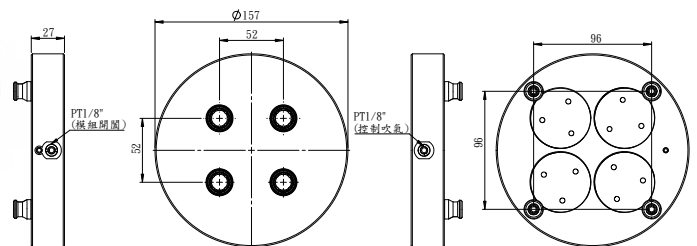

ITEM #	INN02498	AIR CLAMPING FORCE	Max. 1,000 KG	QUICK LOCK	YES
AIR TORQUE	Max. 5~7KG	OIL CLAMPING FORCE	Max. 2,000 KG	DIMENSIONS	Ø157x27mm(pitch 96 to pitch 52)
OIL TORQUE	Max. 40KG	CLAMPING STUD	12mm match INN0295	WELGHT	3.56KG

# INGGRIT 52 ROUND PLATE

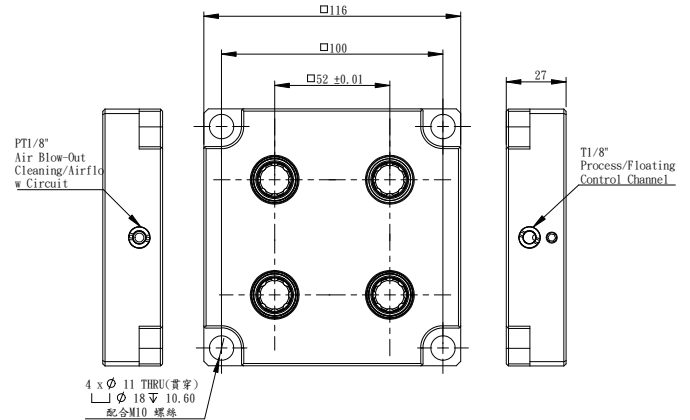

ITEM #	INN02652	AIR CLAMPING FORCE	Max. 1,000 KG	QUICK LOCK	YES
AIR TORQUE	Max. 35~40KG	OIL CLAMPING FORCE	Max. 2,000 KG	DIMENSIONS	116x116x27mm(pitch52)
OIL TORQUE	Max. 40KG	CLAMPING STUD	12mm match INN0295	WELGHT	3.32KG

# INGGRIT 52 ROUND PLATE (AIR)

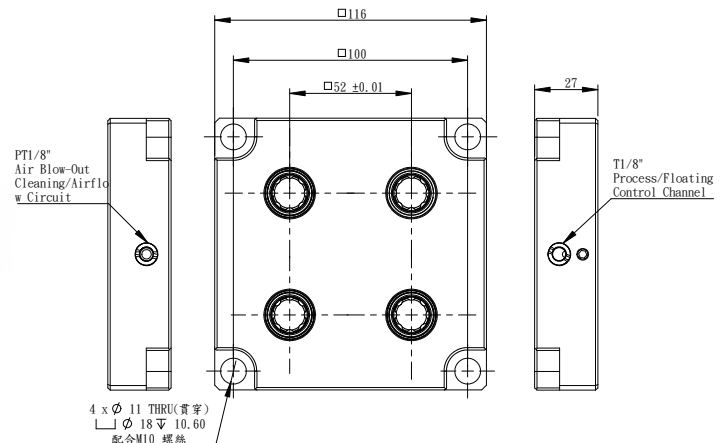

ITEM #	INN02651	AIR CLAMPING FORCE	Max. 1,000 KG	QUICK LOCK	YES
AIR TORQUE	Max. 5~7KG	OIL CLAMPING FORCE	Max. 2,000 KG	DIMENSIONS	116x116x27mm(pitch52)
OIL TORQUE	Max. 40KG	CLAMPING STUD	12mm match INN0295	WELGHT	3.32KG

**UNLTRA THIN**  
**INNGRIT 52 ADAPTOR PLATE**  
 FROM PITCH 96

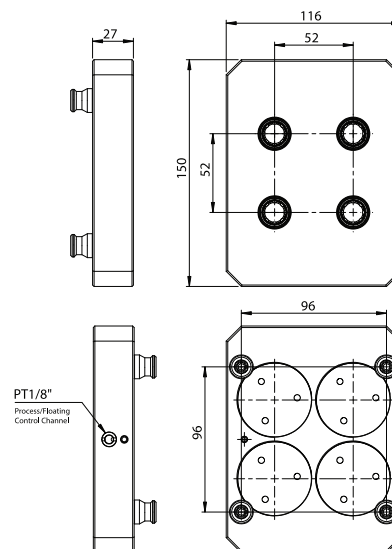

ITEM #	INN02534	AIR CLAMPING FORCE	Max. 1,000 KG	QUICK LOCK	YES
AIR TORQUE	Max. 35~40KG	OIL CLAMPING FORCE	Max. 2,000 KG	DIMENSIONS	116x150x27mm(pitch 96 to pitch 52)
OIL TORQUE	Max. 40KG	CLAMPING STUD	12mm match INN0295	WELGHT	3.1KG

**UNLTRA THIN**  
**INNGRIT 52 ADAPTOR PLATE (AIR)**  
 FROM PITCH 96

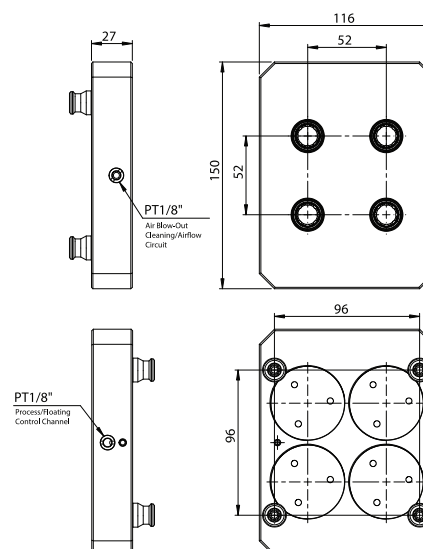

ITEM #	INN02500	AIR CLAMPING FORCE	Max. 1,000 KG	QUICK LOCK	YES
AIR TORQUE	Max. 5~7KG	OIL CLAMPING FORCE	Max. 2,000 KG	DIMENSIONS	116x150x27mm(pitch 96 to pitch 52)
OIL TORQUE	Max. 40KG	CLAMPING STUD	12mm match INN0295	WELGHT	3.1KG



# INGGRIT 52 ROUND PLATE

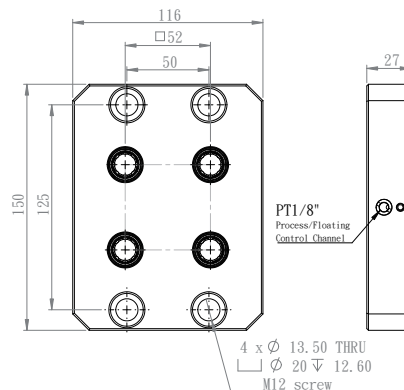

ITEM #	INN02533	AIR CLAMPING FORCE	Max. 1,000 KG	QUICK LOCK	YES
AIR TORQUE	Max. 35~40KG	OIL CLAMPING FORCE	Max. 2,000 KG	DIMENSIONS	116x150x27mm(pitch52)
OIL TORQUE	Max. 40KG	CLAMPING STUD	12mm match INN0295	WELGHT	2.85KG

# INGGRIT 52 ROUND PLATE (AIR)

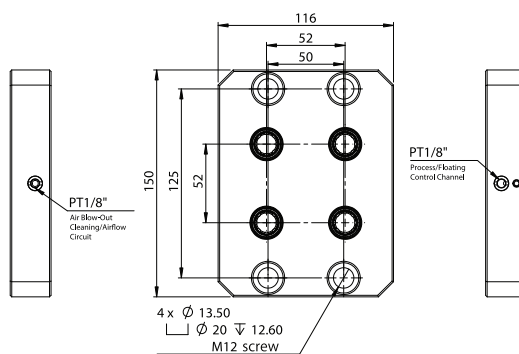

ITEM #	INN02499	AIR CLAMPING FORCE	Max. 1,000 KG	QUICK LOCK	YES
AIR TORQUE	Max. 5~7KG	OIL CLAMPING FORCE	Max. 2,000 KG	DIMENSIONS	116x150x27mm(pitch52)
OIL TORQUE	Max. 40KG	CLAMPING STUD	12mm match INN0295	WELGHT	2.85KG

# INNGRIT 96 ROUND PLATE

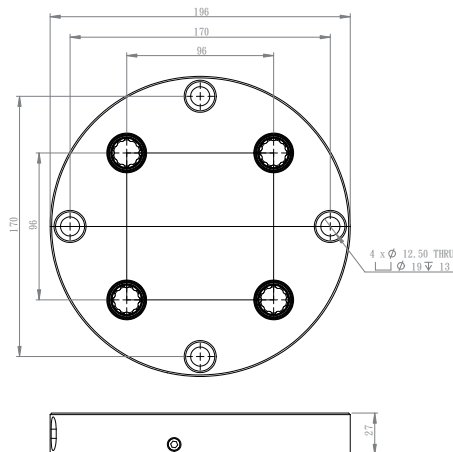

ITEM #	INN02594	AIR CLAMPING FORCE	Max. 1,000 KG	QUICK LOCK	YES
AIR TORQUE	Max. 35~40KG	OIL CLAMPING FORCE	Max. 2,000 KG	DIMENSIONS	Ø196x27mm(pitch96)
OIL TORQUE	Max. 40KG	CLAMPING STUD	16mm match INN02580	WELGHT	5.50KG

# INNGRIT 96 ROUND PLATE (AIR)

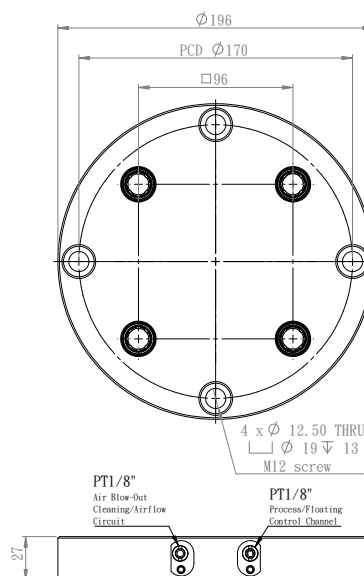

ITEM #	INN02584	AIR CLAMPING FORCE	Max. 1,000 KG	QUICK LOCK	YES
AIR TORQUE	Max. 5~7KG	OIL CLAMPING FORCE	Max. 2,000 KG	DIMENSIONS	Ø196x27mm(pitch96)
OIL TORQUE	Max. 40KG	CLAMPING STUD	16mm match INN02580	WELGHT	5.50KG

## INNGRIT 96 ROUND PLATE

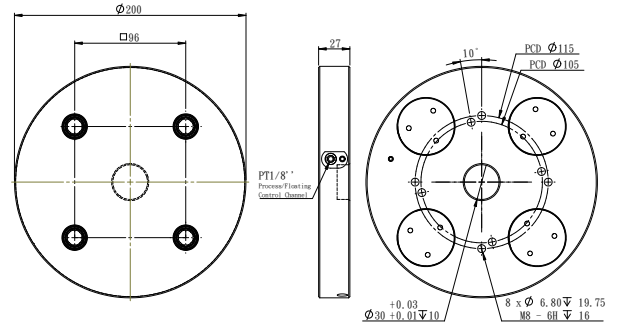

ITEM #	INN02623	AIR CLAMPING FORCE	Max. 1,000 KG	QUICK LOCK	YES
AIR TORQUE	Max. 35~40KG	OIL CLAMPING FORCE	Max. 2,000 KG	DIMENSIONS	Ø200x27mm(pitch96)
OIL TORQUE	Max. 40KG	CLAMPING STUD	16mm match INN02580	WELGHT	5.58KG

## INNGRIT 96 ROUND PLATE (AIR)

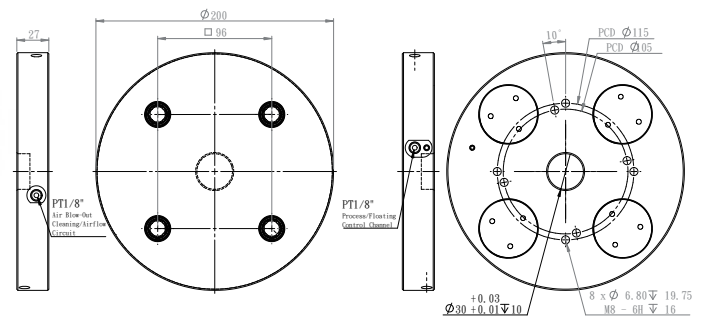

ITEM #	INN02622	AIR CLAMPING FORCE	Max. 1,000 KG	QUICK LOCK	YES
AIR TORQUE	Max. 5~7KG	OIL CLAMPING FORCE	Max. 2,000 KG	DIMENSIONS	Ø200x27mm(pitch96)
OIL TORQUE	Max. 40KG	CLAMPING STUD	16mm match INN02580	WELGHT	5.58KG

# INNGRIT 96 ROUND PLATE

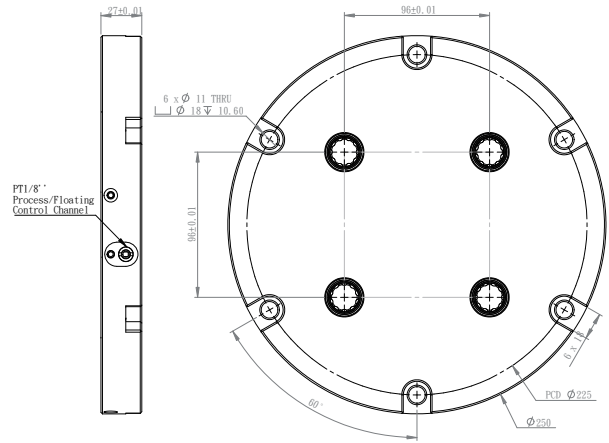

ITEM #	INN02646	AIR CLAMPING FORCE	Max. 1,000 KG	QUICK LOCK	YES
AIR TORQUE	Max. 35~40KG	OIL CLAMPING FORCE	Max. 2,000 KG	DIMENSIONS	Ø250x27mm(pitch96)
OIL TORQUE	Max. 40KG	CLAMPING STUD	16mm match INN02580	WELGHT	9.50KG

# INNGRIT 96 ROUND PLATE (AIR)

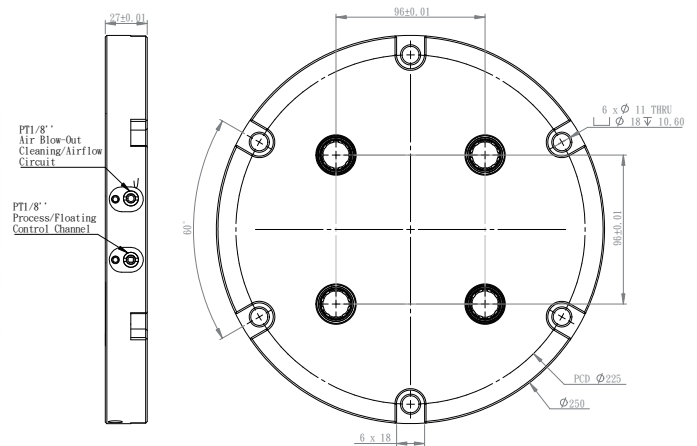

ITEM #	INN02645	AIR CLAMPING FORCE	Max. 1,000 KG	QUICK LOCK	YES
AIR TORQUE	Max. 5~7KG	OIL CLAMPING FORCE	Max. 2,000 KG	DIMENSIONS	Ø250x27mm(pitch96)
OIL TORQUE	Max. 40KG	CLAMPING STUD	16mm match INN02580	WELGHT	9.50KG



## INNGRIT 96 ROUND PLATE

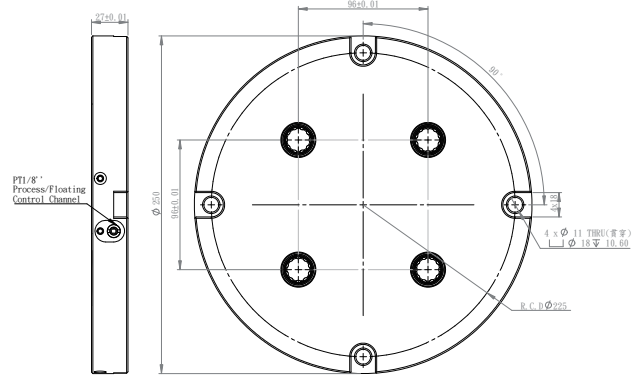

ITEM #	INN02656	AIR CLAMPING FORCE	Max. 1,000 KG	QUICK LOCK	YES
AIR TORQUE	Max. 35~40KG	OIL CLAMPING FORCE	Max. 2,000 KG	DIMENSIONS	Ø250x27mm(pitch96)
OIL TORQUE	Max. 40KG	CLAMPING STUD	16mm match INN02580	WELGHT	9.50KG

## INNGRIT 96 ROUND PLATE (AIR)

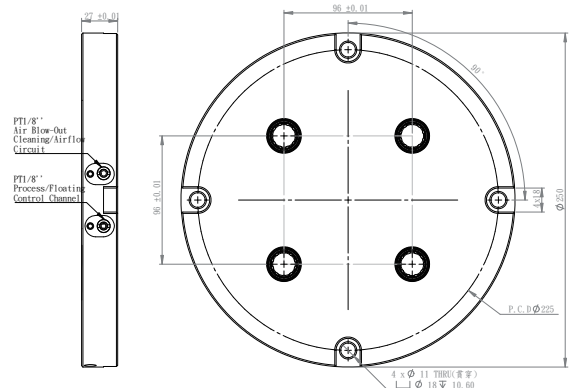

ITEM #	INN02655	AIR CLAMPING FORCE	Max. 1,000 KG	QUICK LOCK	YES
AIR TORQUE	Max. 5~7KG	OIL CLAMPING FORCE	Max. 2,000 KG	DIMENSIONS	Ø250x27mm(pitch96)
OIL TORQUE	Max. 40KG	CLAMPING STUD	16mm match INN02580	WELGHT	9.50KG

## INNGRIT 96 ROUND PLATE

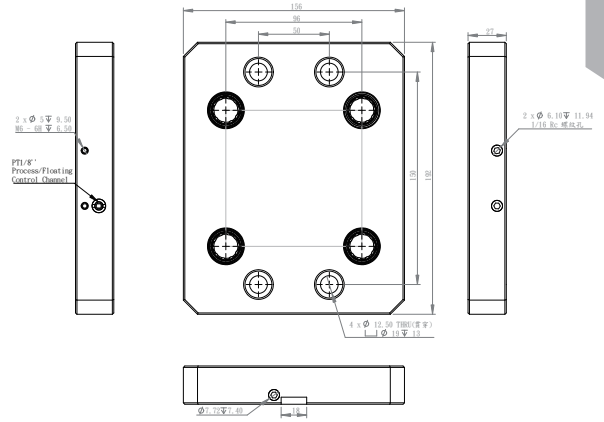

ITEM #	INN02627	AIR CLAMPING FORCE	Max. 1,000 KG	QUICK LOCK	YES
AIR TORQUE	Max. 35~40KG	OIL CLAMPING FORCE	Max. 2,000 KG	DIMENSIONS	192x156x27mm(pitch96)
OIL TORQUE	Max. 40KG	CLAMPING STUD	16mm match INN02580	WELGHT	5.30KG

## INNGRIT 96 ROUND PLATE (AIR)

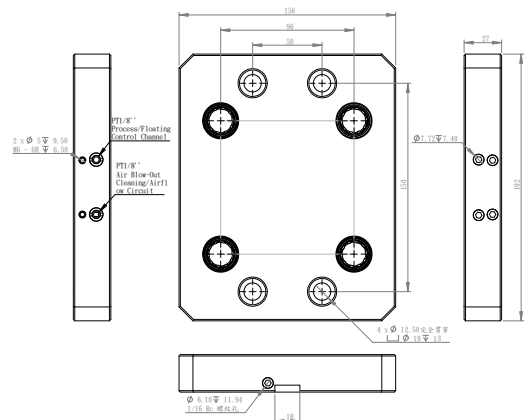

ITEM #	INN02626	AIR CLAMPING FORCE	Max. 1,000 KG	QUICK LOCK	YES
AIR TORQUE	Max. 5~7KG	OIL CLAMPING FORCE	Max. 2,000 KG	DIMENSIONS	192x156x27mm(pitch96)
OIL TORQUE	Max. 40KG	CLAMPING STUD	16mm match INN02580	WELGHT	5.30KG

## INNGRIT 96 ROUND PLATE

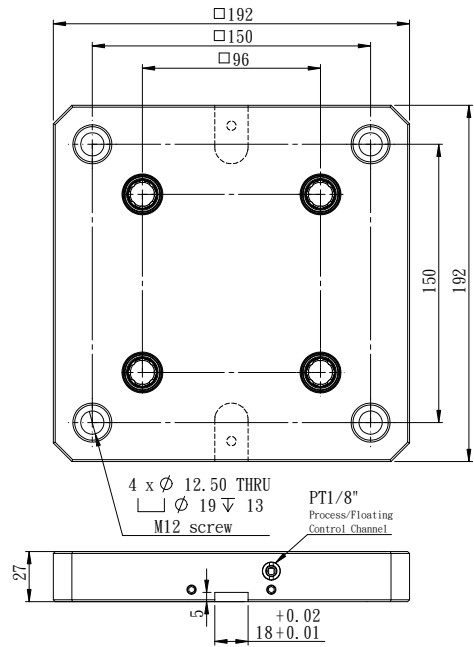

ITEM #	INN02595	AIR CLAMPING FORCE	Max. 1,000 KG	QUICK LOCK	YES
AIR TORQUE	Max. 35~40KG	OIL CLAMPING FORCE	Max. 2,000 KG	DIMENSIONS	192x192x27mm(pitch96)
OIL TORQUE	Max. 40KG	CLAMPING STUD	16mm match INN02580	WELGHT	6.85KG

## INNGRIT 96 ROUND PLATE (AIR)

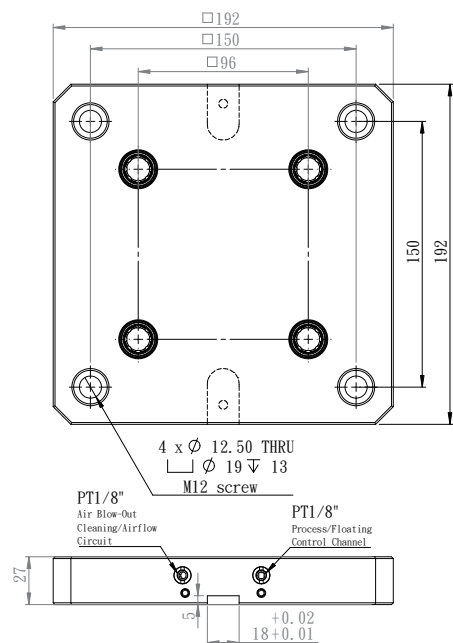

ITEM #	INN02581	AIR CLAMPING FORCE	Max. 1,000 KG	QUICK LOCK	YES
AIR TORQUE	Max. 5~7KG	OIL CLAMPING FORCE	Max. 2,000 KG	DIMENSIONS	192x192x27mm(pitch96)
OIL TORQUE	Max. 40KG	CLAMPING STUD	16mm match INN02580	WELGHT	6.85KG

## INNGRIT 96 ROUND PLATE

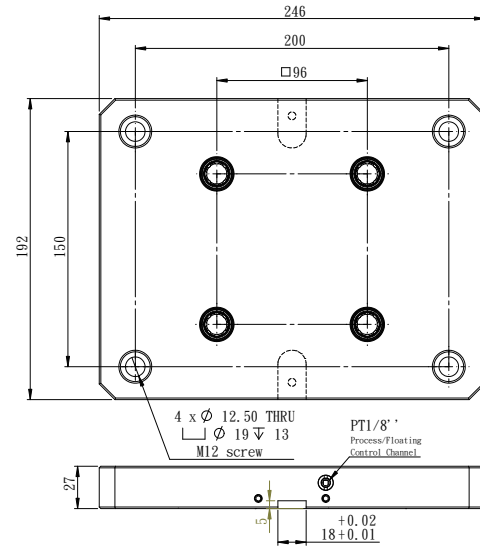

ITEM #	INN02593	AIR CLAMPING FORCE	Max. 1,000 KG	QUICK LOCK	YES
AIR TORQUE	Max. 35~40KG	OIL CLAMPING FORCE	Max. 2,000 KG	DIMENSIONS	246x192x27mm(pitch96)
OIL TORQUE	Max. 40KG	CLAMPING STUD	16mm match INN02580	WELGHT	8.90KG

## INNGRIT 96 ROUND PLATE (AIR)

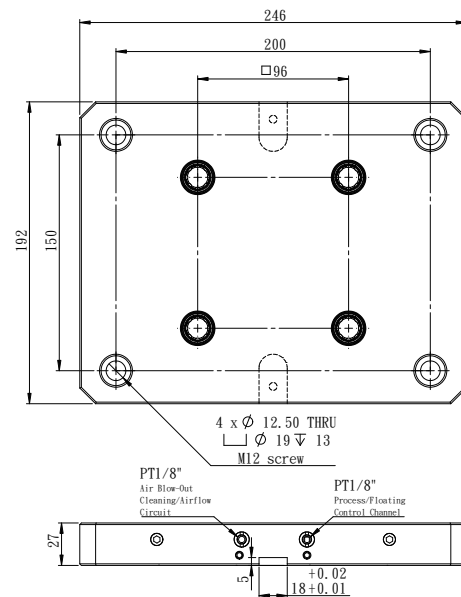
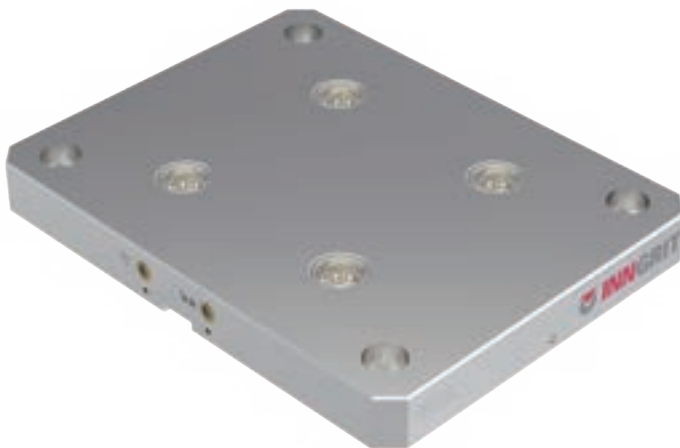

ITEM #	INN02592	AIR CLAMPING FORCE	Max. 1,000 KG	QUICK LOCK	YES
AIR TORQUE	Max. 5~7KG	OIL CLAMPING FORCE	Max. 2,000 KG	DIMENSIONS	246x192x27mm(pitch96)
OIL TORQUE	Max. 40KG	CLAMPING STUD	16mm match INN02580	WELGHT	8.90KG



# INNGRIT 96 MULTIPLATE PLATE

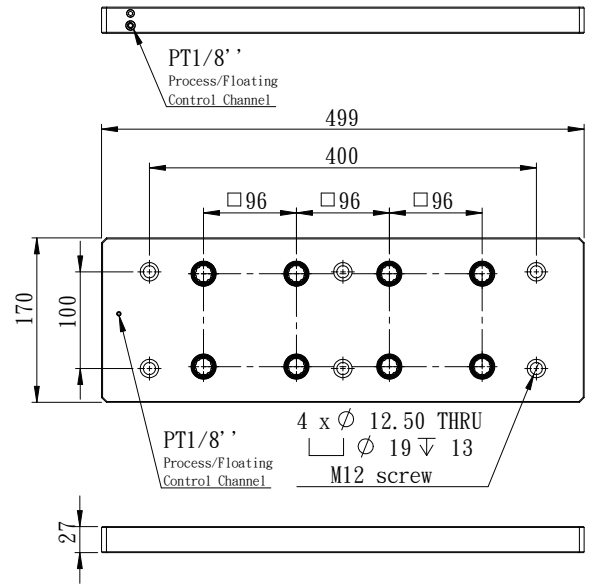

ITEM #	INN02590	AIR CLAMPING FORCE	Max. 1,000 KG	QUICK LOCK	YES
AIR TORQUE	Max. 35~40KG	OIL CLAMPING FORCE	Max. 2,000 KG	DIMENSIONS	499x170x27mm(pitch96)
OIL TORQUE	Max. 40KG	CLAMPING STUD	16mm match INN02580	WELGHT	16.48KG

# INNGRIT 96 MULTIPLATE (AIR)

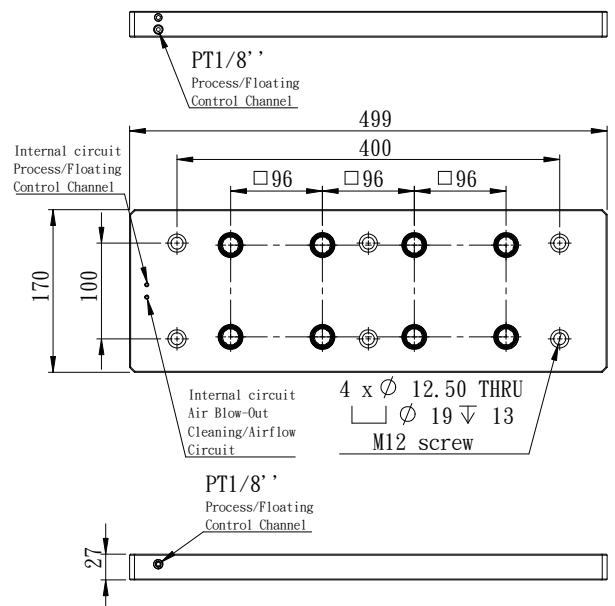

ITEM #	INN02588	AIR CLAMPING FORCE	Max. 1,000 KG	QUICK LOCK	YES
AIR TORQUE	Max. 5~7KG	OIL CLAMPING FORCE	Max. 2,000 KG	DIMENSIONS	499x170x27mm(pitch96)
OIL TORQUE	Max. 40KG	CLAMPING STUD	16mm match INN02580	WELGHT	16.48KG

# INNGRIT 96 MULTIPLATE PLATE

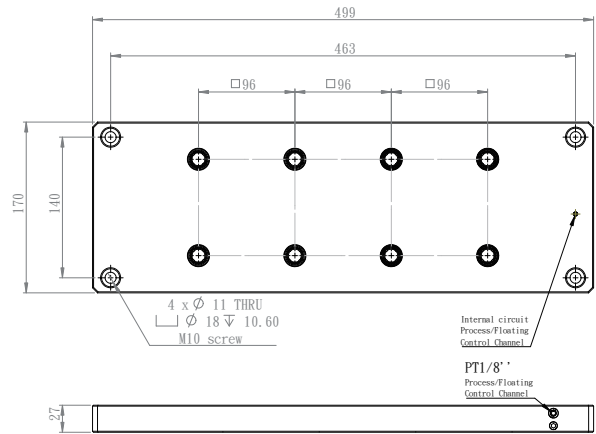

ITEM #	INN02629	AIR CLAMPING FORCE	Max. 1,000 KG	QUICK LOCK	YES
AIR TORQUE	Max. 35~40KG	OIL CLAMPING FORCE	Max. 2,000 KG	DIMENSIONS	499x170x27mm(pitch96)
OIL TORQUE	Max. 40KG	CLAMPING STUD	16mm match INN02580	WELGHT	16.48KG

# INNGRIT 96 MULTIPLATE (AIR)

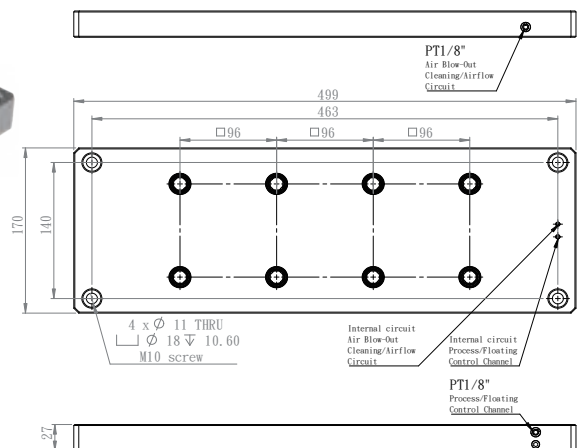

ITEM #	INN02628	AIR CLAMPING FORCE	Max. 1,000 KG	QUICK LOCK	YES
AIR TORQUE	Max. 5~7KG	OIL CLAMPING FORCE	Max. 2,000 KG	DIMENSIONS	499x170x27mm(pitch96)
OIL TORQUE	Max. 40KG	CLAMPING STUD	16mm match INN02580	WELGHT	16.48KG

## INNGRIT 96 ROUND PLATE

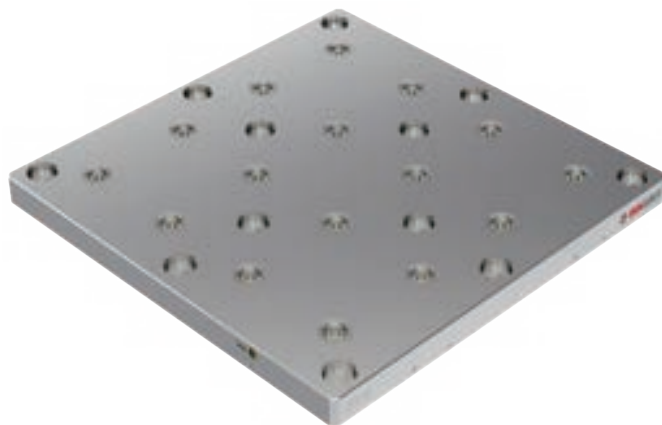

2 x  $\phi$  6.10 $\Psi$  11.94  
1/16 Rc 螺紋孔

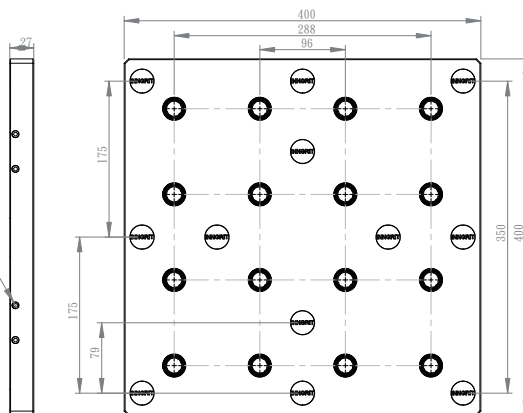

ITEM #	INN02568	AIR CLAMPING FORCE	Max. 1,000 KG	QUICK LOCK	YES
AIR TORQUE	Max. 35~40KG	OIL CLAMPING FORCE	Max. 2,000 KG	DIMENSIONS	249x192x27mm(pitch96)
OIL TORQUE	Max. 40KG	CLAMPING STUD	16mm match INN02580	WELGHT	8.90KG

## INNGRIT 96 ROUND PLATE (AIR)



2 x  $\phi$  6.10 $\Psi$  11.94  
1/16 Rc 螺紋孔

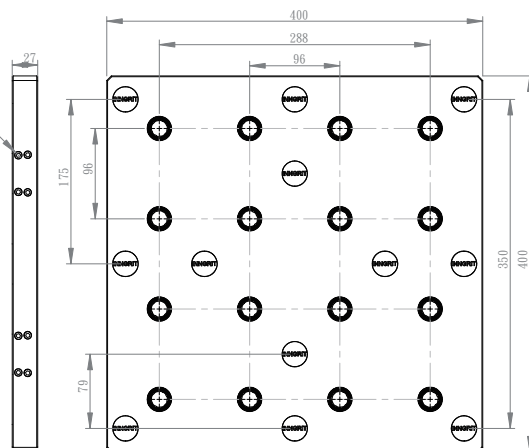

ITEM #	INN02567	AIR CLAMPING FORCE	Max. 1,000 KG	QUICK LOCK	YES
AIR TORQUE	Max. 5~7KG	OIL CLAMPING FORCE	Max. 2,000 KG	DIMENSIONS	246x192x27mm(pitch96)
OIL TORQUE	Max. 40KG	CLAMPING STUD	16mm match INN02580	WELGHT	8.90KG

# INNGRIT 52 ROUND PLATE

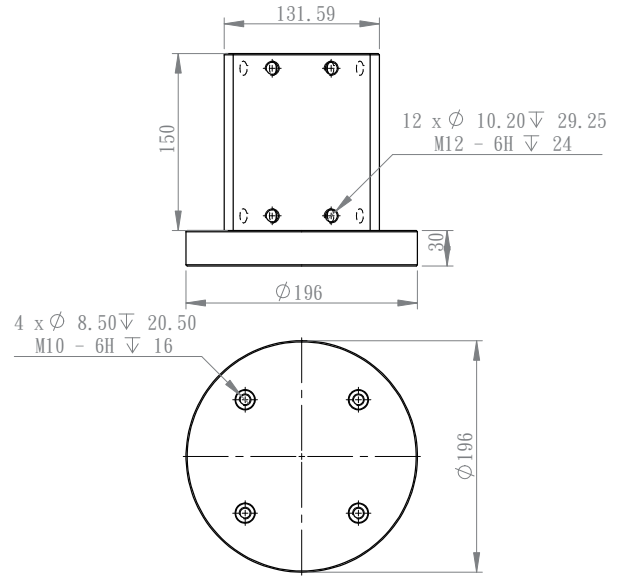

ITEM #	INN02663	AIR CLAMPING FORCE	Max. 1,000 KG	QUICK LOCK	YES
AIR TORQUE	Max. 35~40KG	OIL CLAMPING FORCE	Max. 2,000 KG	DIMENSIONS	customized
OIL TORQUE	Max. 40KG	CLAMPING STUD	12mm match INN0295	WELGHT	

# INNGRIT 96 ROUND PLATE (AIR)

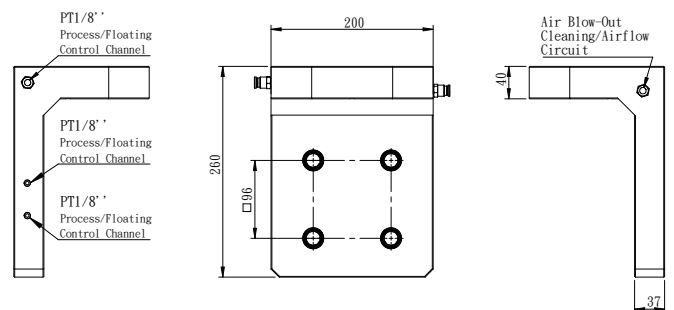

ITEM #	INN02634	AIR CLAMPING FORCE	Max. 1,000 KG	QUICK LOCK	YES
AIR TORQUE	Max. 5~7KG	OIL CLAMPING FORCE	Max. 2,000 KG	DIMENSIONS	180x76x27mm(pitch80)
OIL TORQUE	Max. 40KG	CLAMPING STUD	16mm match INN02580	WELGHT	20.70KG



## INNGRIT 170~200 L SHAPE CLAMP

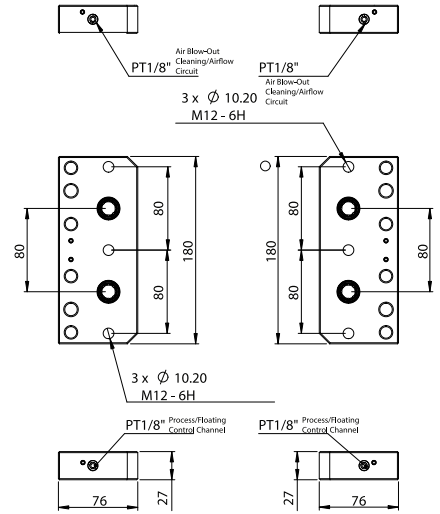

ITEM #	INN02524	AIR CLAMPING FORCE	Max. 1,000 KG	QUICK LOCK	YES
AIR TORQUE	Max. 35~40KG	OIL CLAMPING FORCE	Max. 2,000 KG	DIMENSIONS	180x76x27mm(pitch80)
OIL TORQUE	Max. 40KG	CLAMPING STUD	12mm match INN0295	WELGHT	4.60KG (side panel excluded)

## INNGRIT 170~200 L SHAPE CLAMP (AIR)

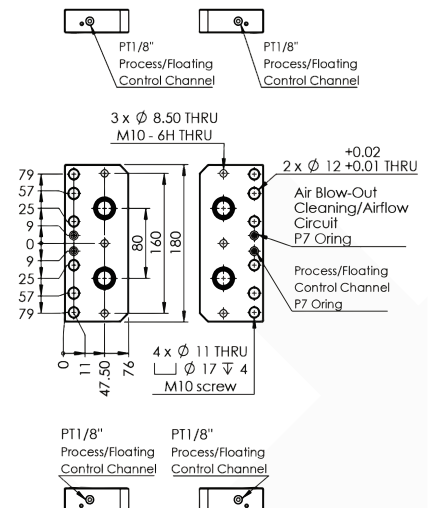

ITEM #	INN02637	AIR CLAMPING FORCE	Max. 1,000 KG	QUICK LOCK	YES
AIR TORQUE	Max. 5~7KG	OIL CLAMPING FORCE	Max. 2,000 KG	DIMENSIONS	180x76x27mm(pitch80)
OIL TORQUE	Max. 40KG	CLAMPING STUD	12mm match INN0295	WELGHT	4.60KG (side panel excluded)

# INNGRIT 255 L SHAPE CLAMP

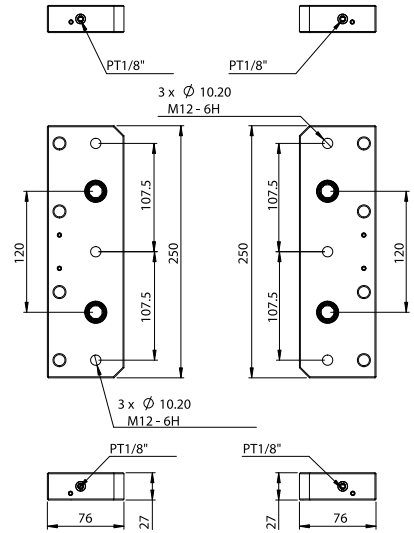

ITEM #	INN02636	AIR CLAMPING FORCE	Max. 1,000 KG	QUICK LOCK	YES
AIR TORQUE	Max. 35~40KG	OIL CLAMPING FORCE	Max. 2,000 KG	DIMENSIONS	250x76x27mm(pitch120)
OIL TORQUE	Max. 40KG	CLAMPING STUD	12mm match INN0295	WELGHT	45.73KG (side panel excluded)

# INNGRIT 255 L SHAPE CLAMP (AIR)

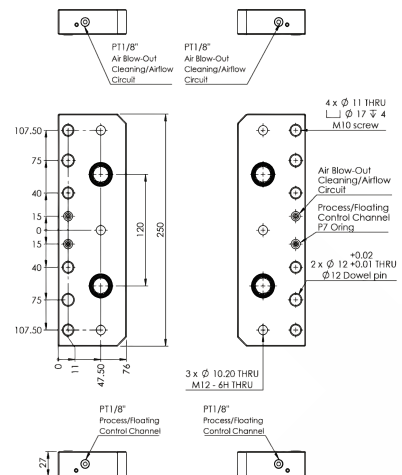

ITEM #	INN02635	AIR CLAMPING FORCE	Max. 1,000 KG	QUICK LOCK	YES
AIR TORQUE	Max. 5~7KG	OIL CLAMPING FORCE	Max. 2,000 KG	DIMENSIONS	250x76x27mm(pitch120)
OIL TORQUE	Max. 40KG	CLAMPING STUD	12mm match INN0295	WELGHT	45.73KG (side panel excluded)

## INNGRIT 52 SINGLE PLATE Aluminum(AL)

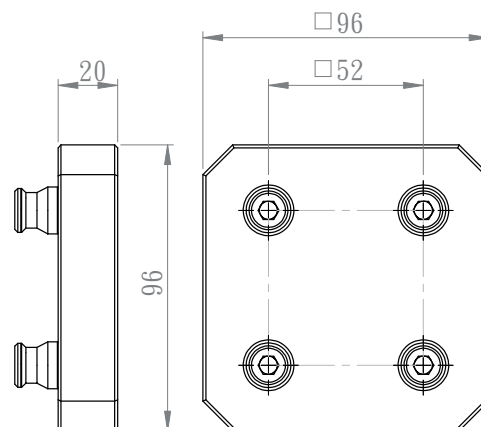
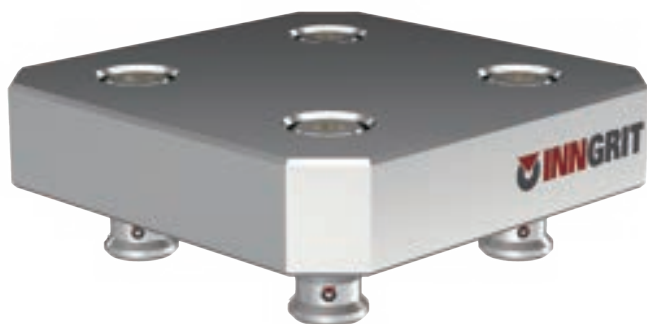

ITEM #	INN02243	AIR CLAMPING FORCE	Max. 1,000 KG	QUICK LOCK	YES
AIR TORQUE	Max. 5~7KG	OIL CLAMPING FORCE	Max. 2,000 KG	DIMENSIONS	96x96x20mm(pitch52)
OIL TORQUE	Max. 40KG	CLAMPING STUD	12mm match INN0295	WELGHT	0.60KG

## INNGRIT 52 SINGLE PLATE (stainless)

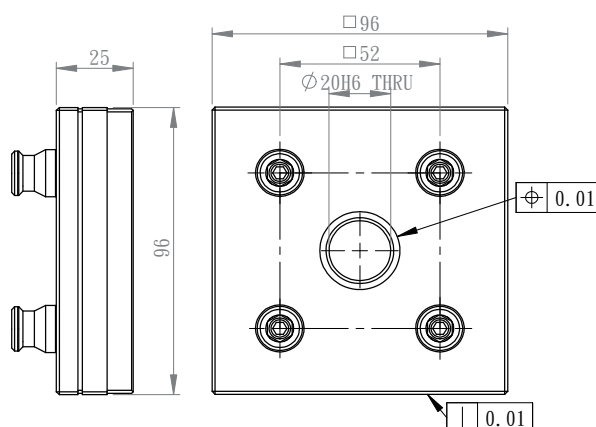
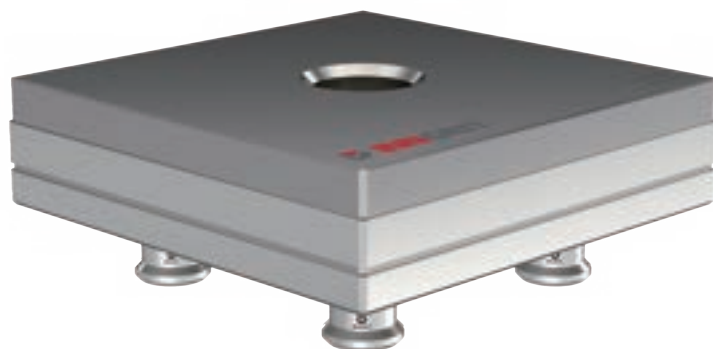

ITEM #	INN02508	AIR CLAMPING FORCE	Max. 1,000 KG	QUICK LOCK	YES
AIR TORQUE	Max. 5~7KG	OIL CLAMPING FORCE	Max. 2,000 KG	DIMENSIONS	96x96x25mm(pitch52)
OIL TORQUE	Max. 40KG	CLAMPING STUD	12mm match INN0295	WELGHT	1.73KG

## INNGRIT 96 SINGLE PLATE Aluminum(AL)

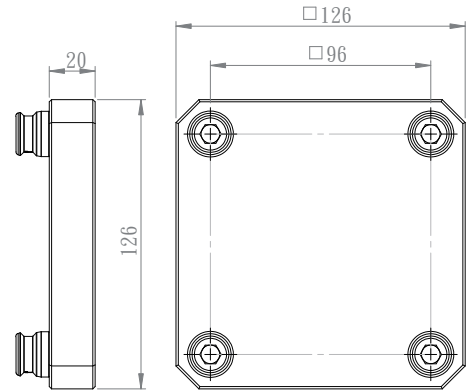

ITEM #	INN02244	AIR CLAMPING FORCE	Max. 1,000 KG	QUICK LOCK	YES
AIR TORQUE	Max. 5~7KG	OIL CLAMPING FORCE	Max. 2,000 KG	DIMENSIONS	126x126x20mm(pitch96)
OIL TORQUE	Max. 40KG	CLAMPING STUD	16mm match INN02580	WELGHT	1.00KG

## INNGRIT 96 SINGLE PLATE (stainless)

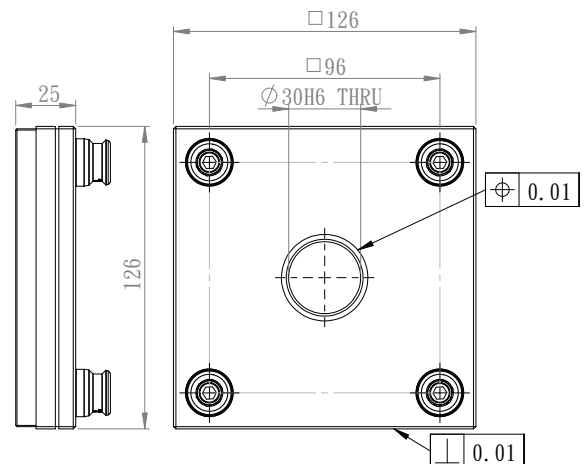
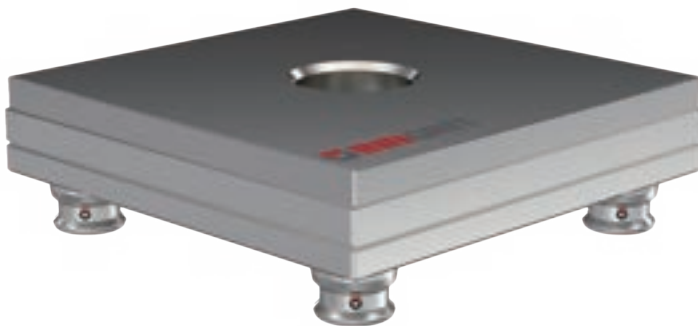

ITEM #	INN02586	AIR CLAMPING FORCE	Max. 1,000 KG	QUICK LOCK	YES
AIR TORQUE	Max. 5~7KG	OIL CLAMPING FORCE	Max. 2,000 KG	DIMENSIONS	126x126x25mm(pitch96)
OIL TORQUE	Max. 40KG	CLAMPING STUD	16mm match INN02580	WELGHT	2.92KG



## INNGRIT SCREW DUST COVER



## INNGRIT BUSHINGS



ITEM #            INN0246  
DIMENSIONS    Ø25x17.8mm  
FOR SCREW SIZE M10



ITEM #            INN0248  
DIMENSIONS    Ø25.5x17.8mm  
FOR SCREW SIZE M12



ITEM #            INN02575  
DIMENSIONS    Ø18.9x12.8mm  
FOR SCREW SIZE M12 Transfer M10

## INNGRIT CLAMPING STUDS



# INNGRIT CLAMPING STUDS

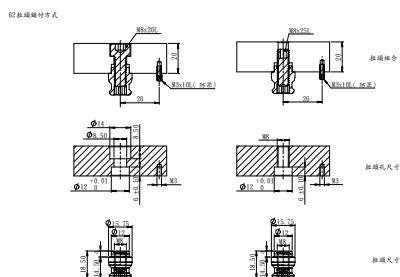

ITEM # INN0295  
pitch52 CLAMPING STUD  
QUICK LOCK YES  
DIMENSIONS 15.75x18.50mm  
WELGHT 0.01KG

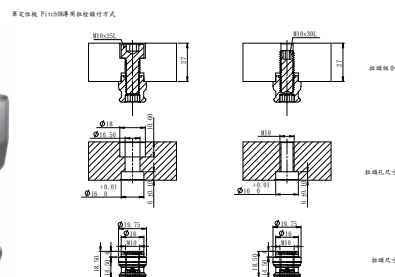

ITEM # INN02580  
pitch96 CLAMPING STUD  
QUICK LOCK YES  
DIMENSIONS 19.75x18.50mm  
WELGHT 0.03KG

# INNGRIT CLAMPING STUDS

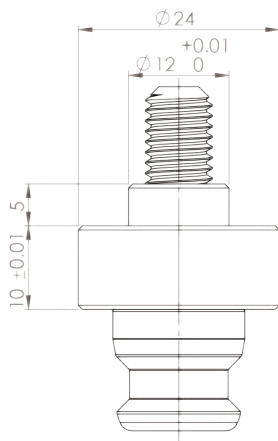

ITEM # INN02469005  
pitch52 CLAMPING STUD  
QUICK LOCK YES  
DIMENSIONS 24x29.50mm  
WELGHT 0.03KG

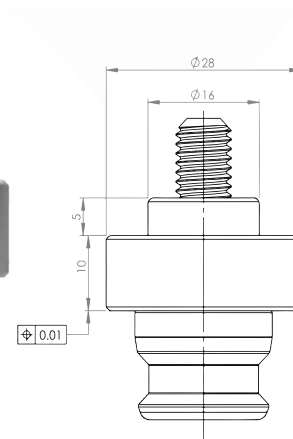

ITEM # INN02469006  
pitch96 CLAMPING STUD  
QUICK LOCK YES  
DIMENSIONS 28x29.50mm  
WELGHT 0.03KG







## WE'RE HERE FOR YOU

INNGRIT is headquartered in the Sinji industrial park, on the outskirts of Tainan, Taiwan's old capital. Here, our dedicated team dream-up, design, build, and test our Zero Point Clamp and Plate systems, as well as service for our customer for Smart Machining Solutions.

Our dedicated team work around the clock to continually innovate with grit, to ensure that our product and services meet your exacting standards and needs in a timely fashion.