

VMC

Vertical Machining Center

YCM PRODUCT LINES

FP Series High Precision High Performance Die Mold Vertical Machining Center
 FP66A, FP100A, NFP66A



NXV Series High Performance Vertical Machining Center
 NXV600A, NXV560A-APC, NXV1020A/AM, NXV1380A, NXV1680A/B

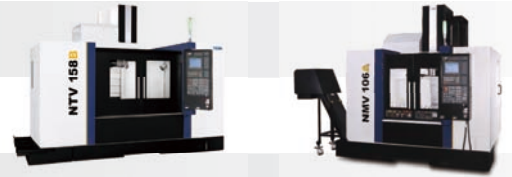

TV Series Heavy Duty Vertical Machining Center
 TV116B, TV146B, TV158B, TV188B, TV2110B, TV2610B

NTV Series High Efficiency T-base Vertical Machining Center
 NTV158A/B

NMV Series High Performance High Rigidity Vertical Machining Center
 NMV76A, NMV106A



WV Series Ultra Wide High Performance Vertical Machining Center
 WV108A/B

NFX Series High Performance 5-axis Vertical Machining Center
 NFX400A

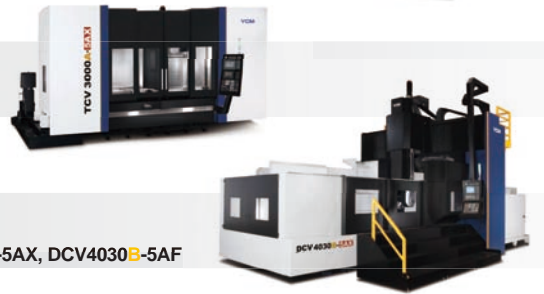

NSV Series Ultra High Performance Vertical Machining Center
 NSV66A, NSV106A/AM/AS/AMS, NSV156A/AM

TCV Series High Performance Traveling Column Vertical Machining Center
 TCV2000A, TCV3000A, TCV4500B, TCV2300A-4A, TCV3000A-4A/5AF/5AX

DCV Series Advanced Double Column Vertical Machining Center
 DCV2012A/B, DCV3016B-6035B, DCV2018A-4018A-5AX, DCV4030B-6030B-5AX, DCV4030B-5AF

NDC Series High Performance Double Column Vertical Machining Center
 NDC2016B-4016B, NDC3022B-6027B, NDC2018B-4018B-AHC, NDC3022B-6027B-AHC

HMC

Horizontal Machining Center

NH Series High Speed High Precision Horizontal Machining Center
 NH500A, NH630B, NH800B

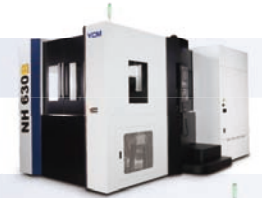

CNC LATHES

CNC Turning Center

NT Series High Performance Mill/Turn Center
 NT-2500SY



GT Series High Performance Geo Turning Center
 GT-200B/MA, GT-250B/MA, GT-300B/MA/LMB

TC Series High Performance High Precision CNC Lathe
 TC-16LA/LB, TC-26, TC-36, TC-46 1000/1650/2300/3200, TC-46M 3200

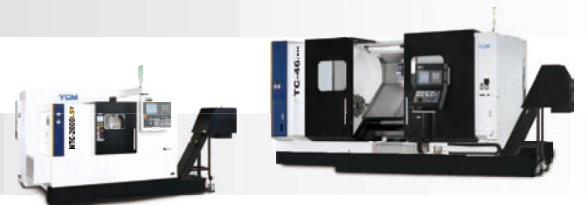

NTC Series High Efficiency CNC Turning Center
 NTC-2000LY/LSY

INTEGRATION AND SOLUTIONS



Integrated Operation Control System



Spindle Thermal Compensation System



Intelligent Production Management

Automation Solutions



YEONG CHIN MACHINERY INDUSTRIES CO., LTD.

No. 888, Sec. 1, Homu Road, Shengang District, Taichung 42953, Taiwan

Tel : +886-4-2562-3211

Fax: +886-4-2562-6479

Web Page: WWW.YCMCNC.com

Email: sales@YCMCNC.com



201908-E02-2000

NH 500A

High Production & Accuracy Horizontal Machining Center

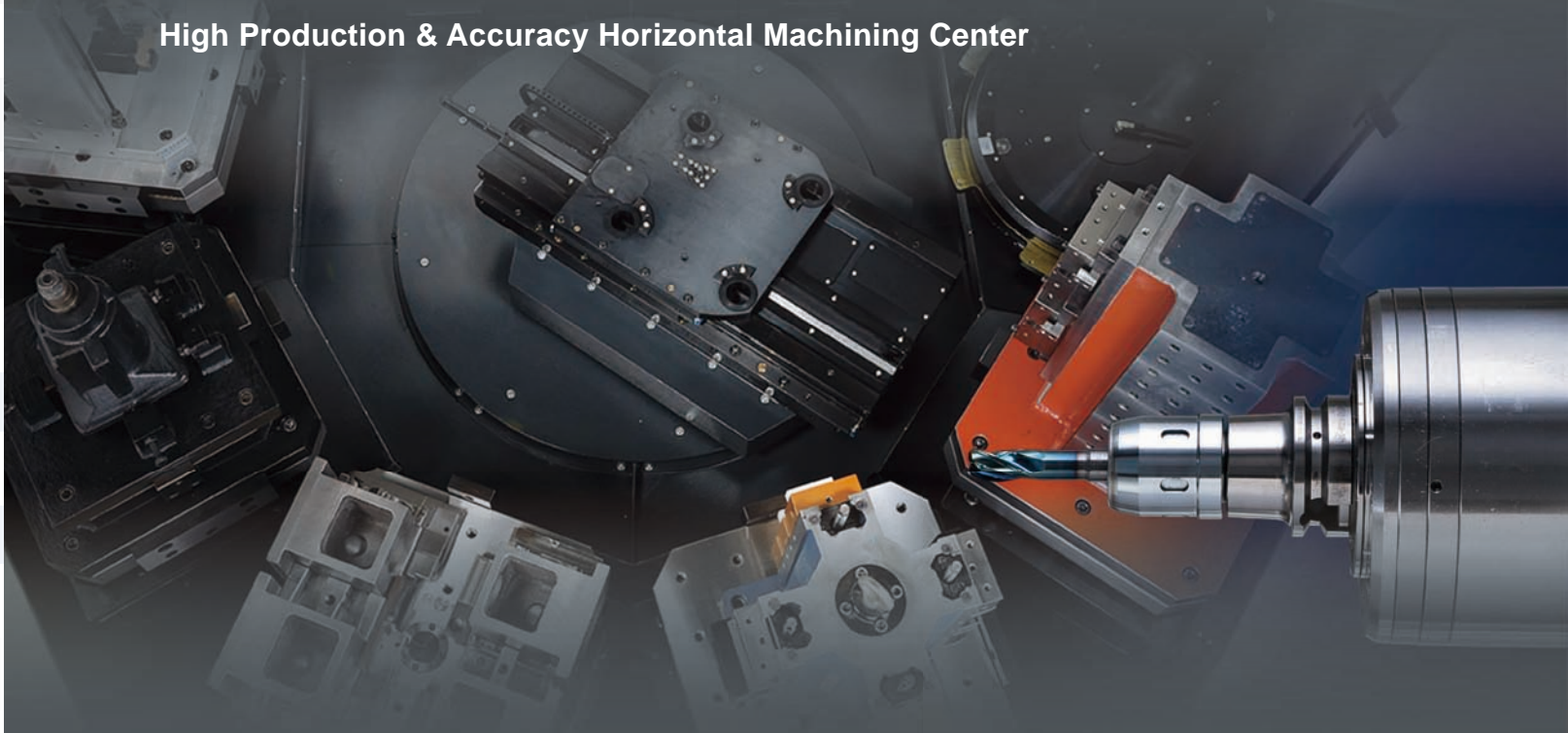

YCM®

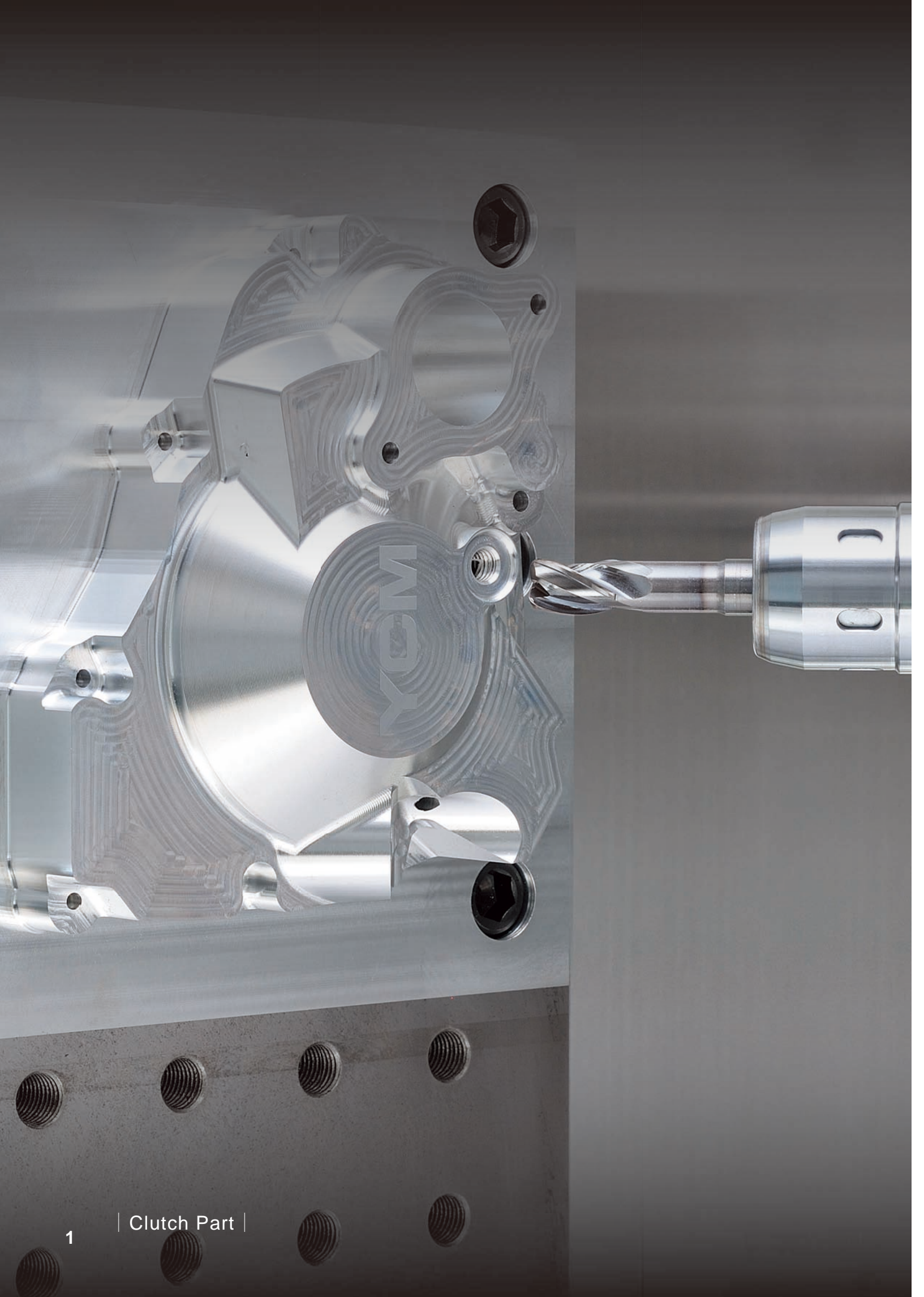

| Clutch Part |

The Power of Agility

YCM **NH 500A** offers high efficiency and high precision in multi-faceted machining and hole drilling. With jig / fixture tower, it centralizes loading and unloading procedure, and also allows multiple workpieces machining that significantly shortens processing time.

NH 500A is well-suited for "mass production" of automotive parts such as transmission box parts, cylinder head, valve parts and pump components.



NH 500A

Rigidity · Precision · Speed

NH 500A is a high performance horizontal machining center particularly designed for automotive, precise & mechanical parts industries.

Featuring rigidity and accuracy, NH 500A is the perfect solution to small batch and mass production types.



- Spindle Speed: **15,000 rpm (20,000rpm opt.)**
- Rapid Feedrate (X / Y / Z): **60m/min.**
- Acceleration Enhancement (X / Y / Z): **1g**
- Auto Tool Change Time: T to T **2 sec.** / C to C **5 sec.**
- Auto Pallet Change: **11 sec.**
- Maximum table rotation speed: **22.2 rpm/min**

High Rigidity Structural Design

- One piece T-base structure with rib construction for unprecedented rigidity.
- Dual-wall column design for enhancing rigidity and durability.
- Adopted FEM analysis for lightweight design to improve G value that can prolong ballscrew life and reduce energy consumption.



All Roller Type Guideways

- XYZ axes are equipped with roller guideways to increase rigidity and accuracy.
- High dynamic AC servo driven pre-tensioned ball screws, delivering high control qualities.

Stepped Design on X-axis

- Two X-axis guideways are positioned at different height to increase stable and reliable rapid axial movement.
- Compact column design is able to achieve higher acceleration and performance.

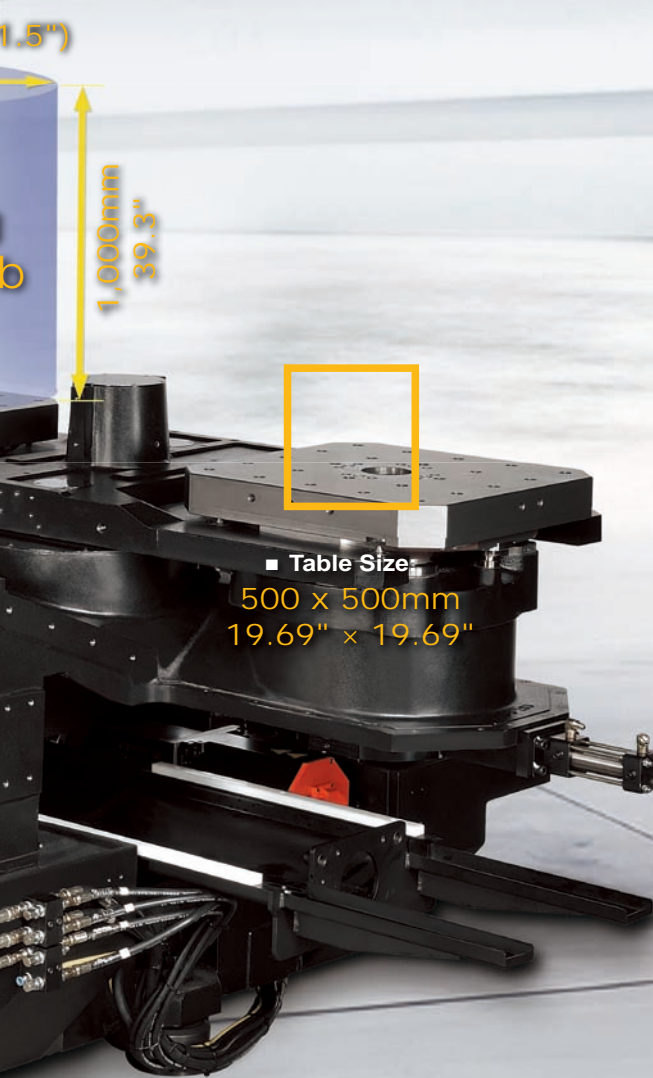

■ Table Size:
500 x 500mm
19.69" x 19.69"

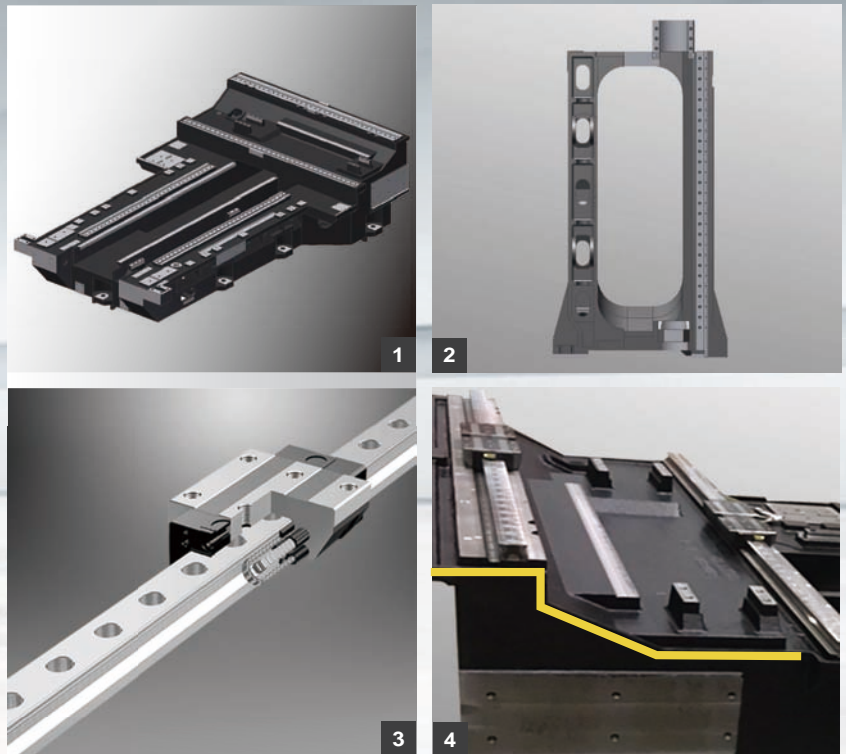

| 1. One-piece T-base Design | 2. Dual-wall column design |
| 3. All Roller Type Guideways | 4. Step X-axis Guideways with Slant Bed Design |

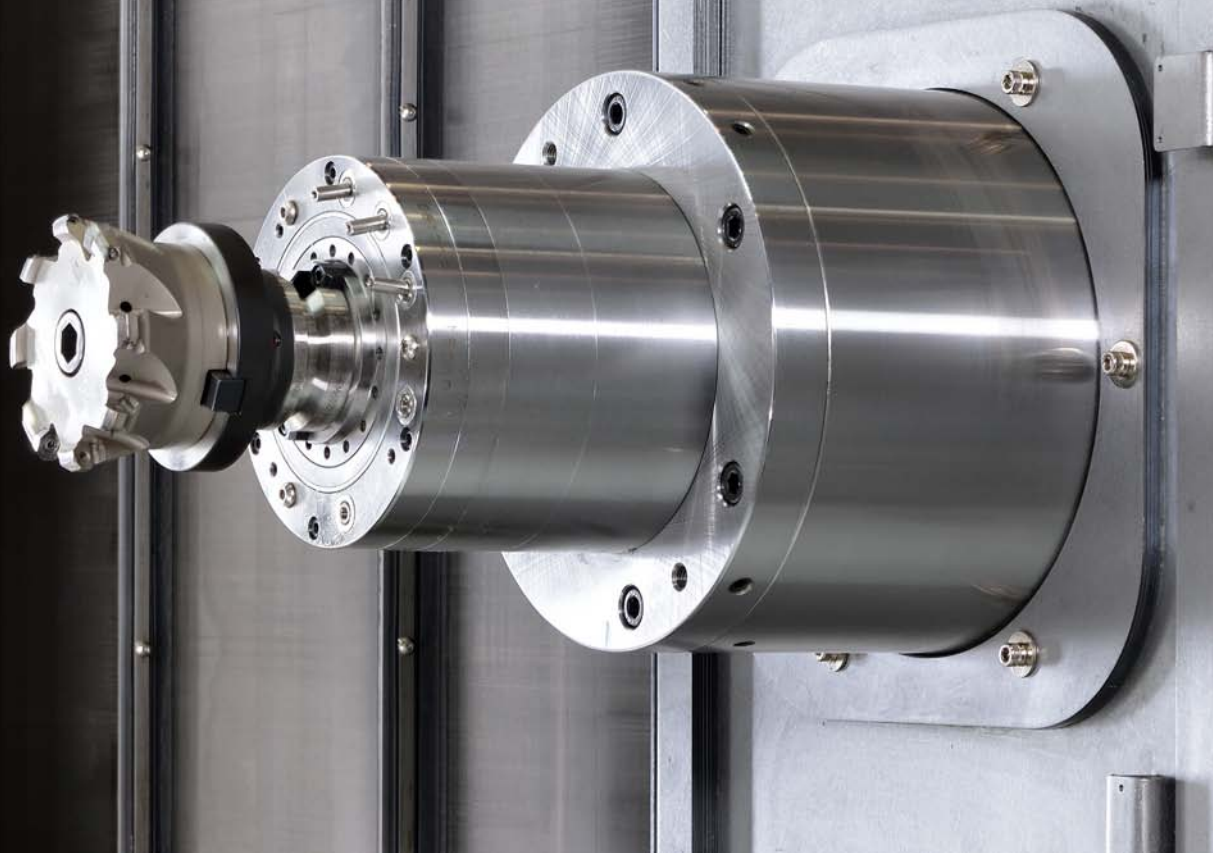

Powerful IDD Spindle

- The standard IDD spindle design, easy for maintenance 15,000 rpm max. spindle speed with 37 kW output delivers 244 Nm torque.
- The powerful spindle utilizes high precision ceramic ball bearings.
- The spindle oil cooling system effectively minimizes thermal deformation.

BBT40 Dual-Contact Spindle Taper

- Equipped with BBT dual-contact to improve cutting capacity and accuracy, also enhance spindle and tool life.

Optimized Spindle Design

- Coolant through spindle system: 20 bar (std.) / 70 bar (opt.).
- Spindle air seal protected.
- Labyrinth protection design.

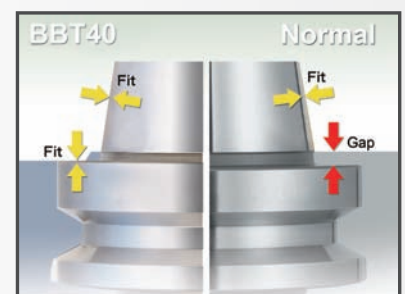

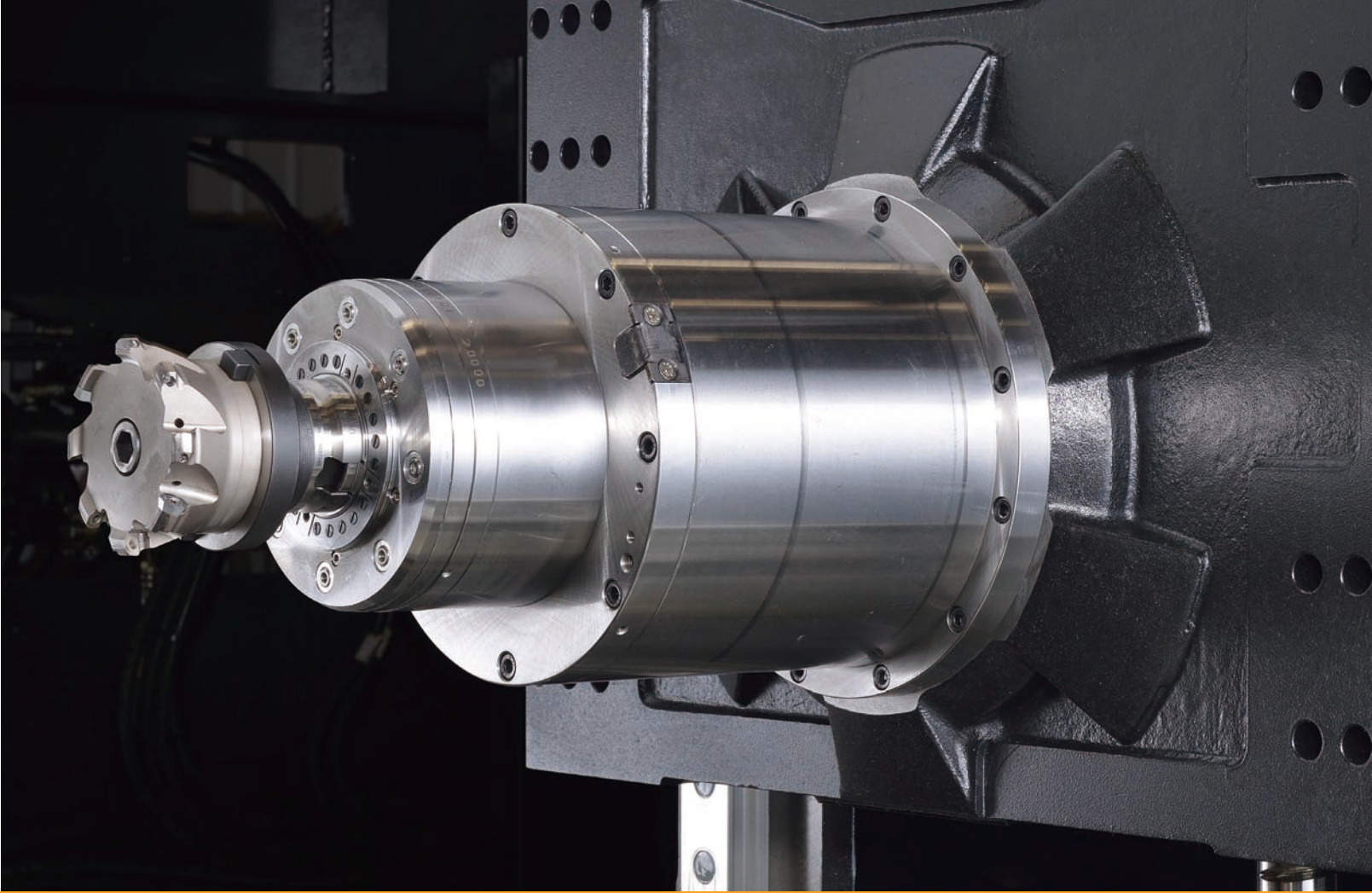

High Performance Built-in Motorized Spindle

- The max. spindle speed reaches up to 20,000 rpm with 22.5 kW output delivers 61 Nm torque (opt.).
- Micro oil-air lubrication for angular ceramic ball bearings prolongs spindle life.
- Circulated oil jacket cooling system minimize thermal deformation, ensuring high accuracy.
- Easy spindle unit replacement reduces maintenance time.

Power Chart

POWER

TORQUE

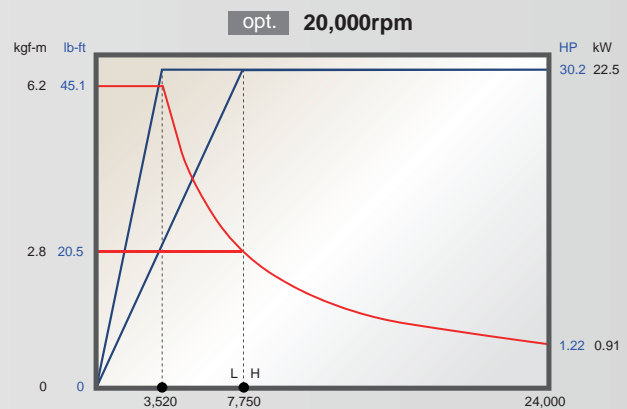
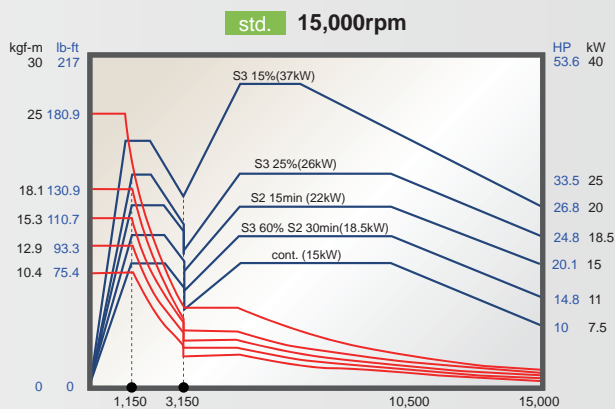

Dependable Pallet Indexing System

- Flange contact taper cone with excellent clamping power and high pallet-positioning precision.



Automatic Pallet Change

- 11-second pallet change servo motor driven.
- Maximum table rotation speed: 22.2 rpm/min

	Min. Table Indexing Angle	Table Indexing Time*
Index Table	1°	4.3 sec. (90°)

*Including clamping and unclamping time.

Cutting Capacity

Spindle Speed 15,000 rpm **std.**

FACE MILL **S45C Steel**

Material Removal Rate

806 cc/min.

Tool ø63 mm x 5T
 Spindle Speed 1,400 rpm
 Feedrate 4,200 mm/min.
 Width of Cut 60 mm
 Depth of Cut 3.2 mm

FACE MILL **S45C Steel**

Depth of Cut

9 mm

Tool ø80 mm x 5T
 Spindle Speed 600 rpm
 Feedrate 450 mm/min.
 Width of Cut 60 mm
 Depth of Cut 9 mm

High Efficiency Six Pallets System for Flexible Production Needs (opt.)

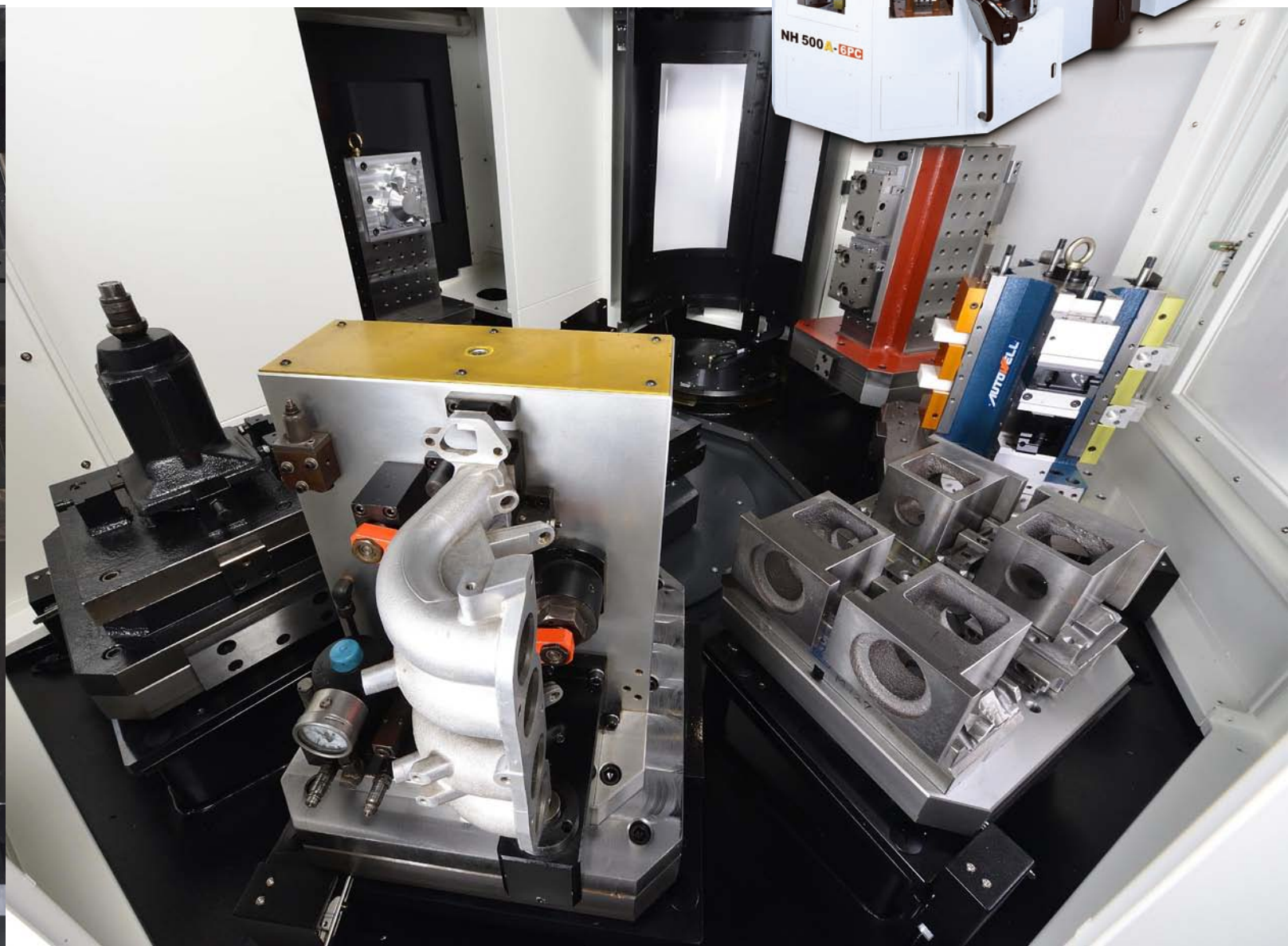

Max. TAPPING

S45C Steel

Tapping (Max.)

M42

Tool M42 x 4.5P
 Spindle Speed 38 rpm
 Feedrate 171 mm/min.
 Width of Cut 42 mm
 Depth of Cut 30 mm

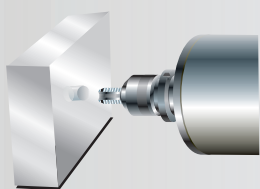

FACE MILL

A6061 Aluminum

Material Removal Rate

3,175

 cc/min.

Tool \varnothing 40 mm x 4T
 Spindle Speed 12,000 rpm
 Feedrate 20,160 mm/min.
 Width of Cut 35 mm
 Depth of Cut 4.5 mm

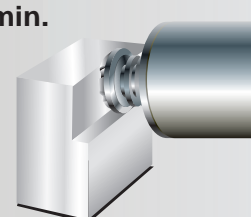

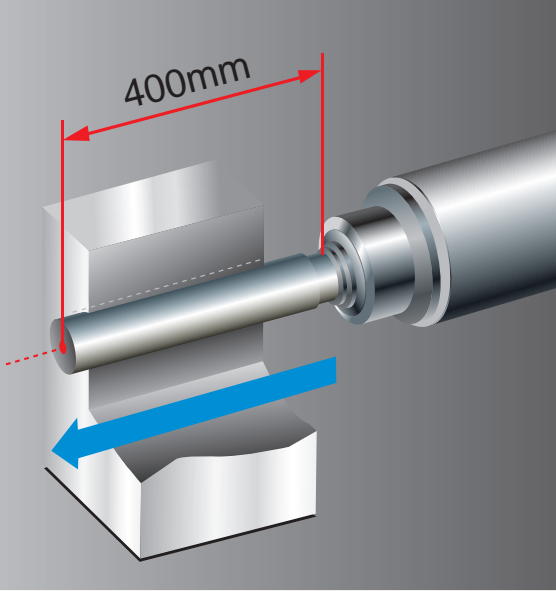

■ Max. Tool Length: 400mm 15.7"

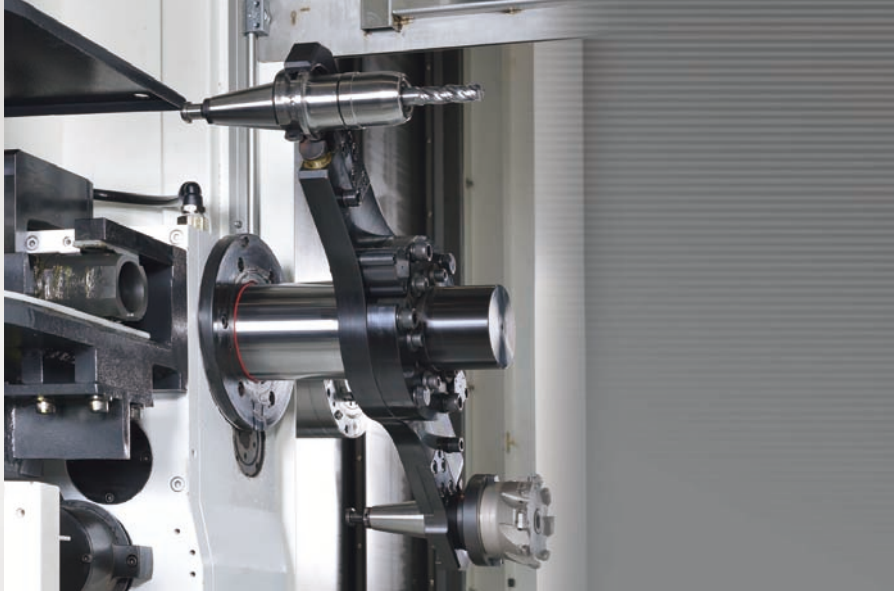

■ Auto Tool Change Time (T-T): 2 sec. / (C-C): 5 sec.

Reliable Automatic Tool Change

- It takes 2 seconds to complete one cycle of tool to tool change.
- ATC speed is programmable in high & low speed.
- Servo motor driven tool magazine.
- 60T for disc type tool magazine (std.).
- 120T for chain type (opt.).



■ 60T std.

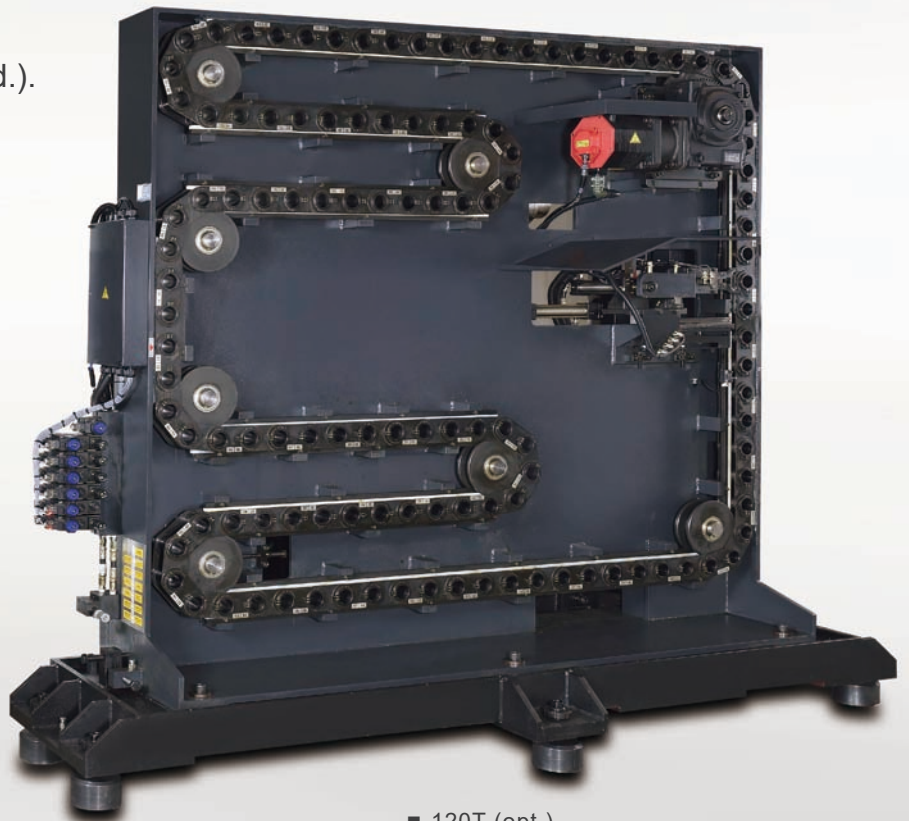

■ 120T (opt.)

- Dual chip augers are utilized for efficient chips removal. std.



Dimensions

Unit: mm inch

NH500A

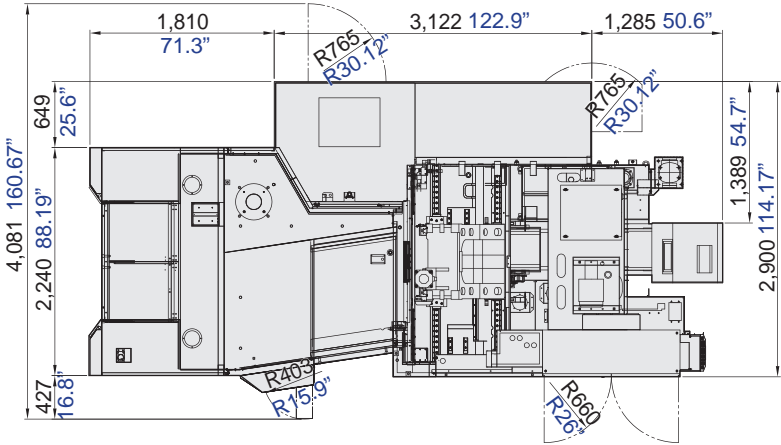
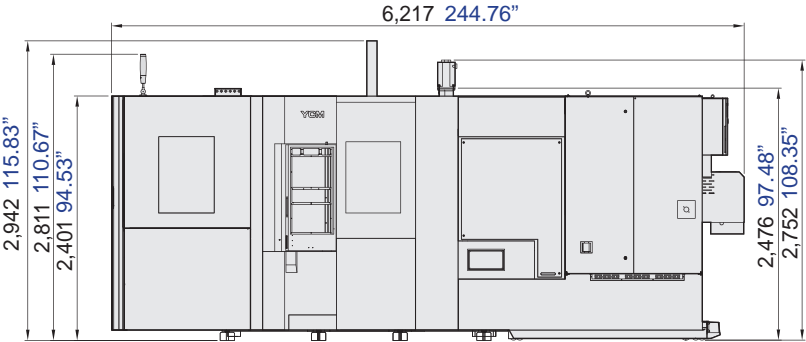
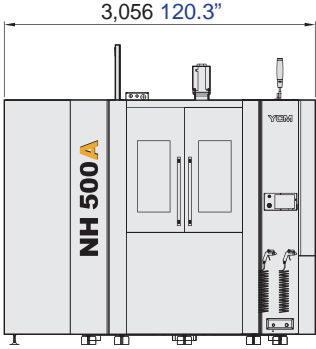

Drawing of Interference

Max. Workpiece Rotary Diameter $\varnothing 2,000$ $\varnothing 78.7$ "

Max. Workpiece Diameter $\varnothing 880$ $\varnothing 34.7$ "

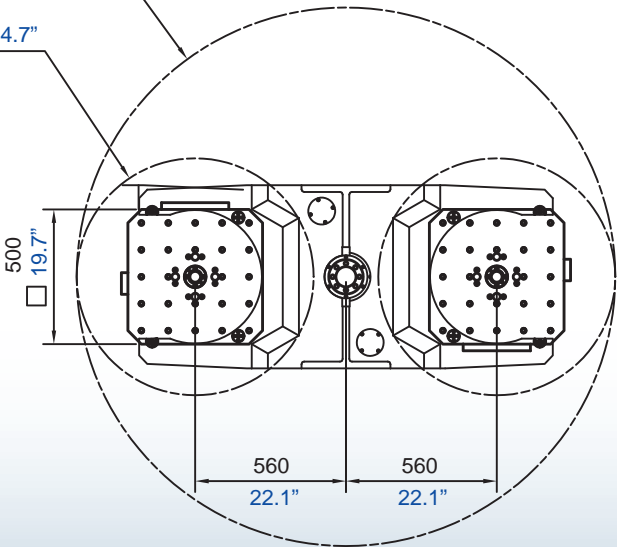

Dimensions

Unit: mm inch

NH500A-6PC

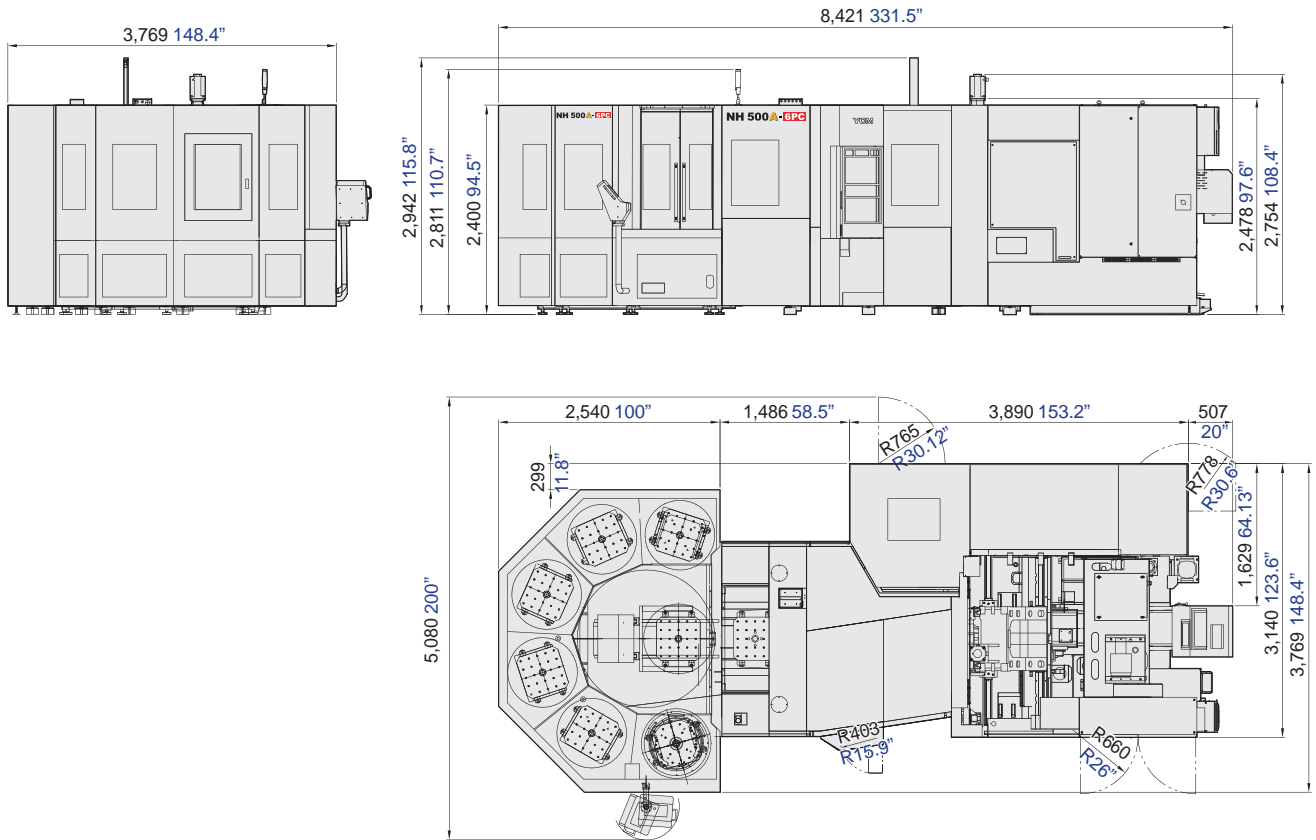

Drawing of Interference

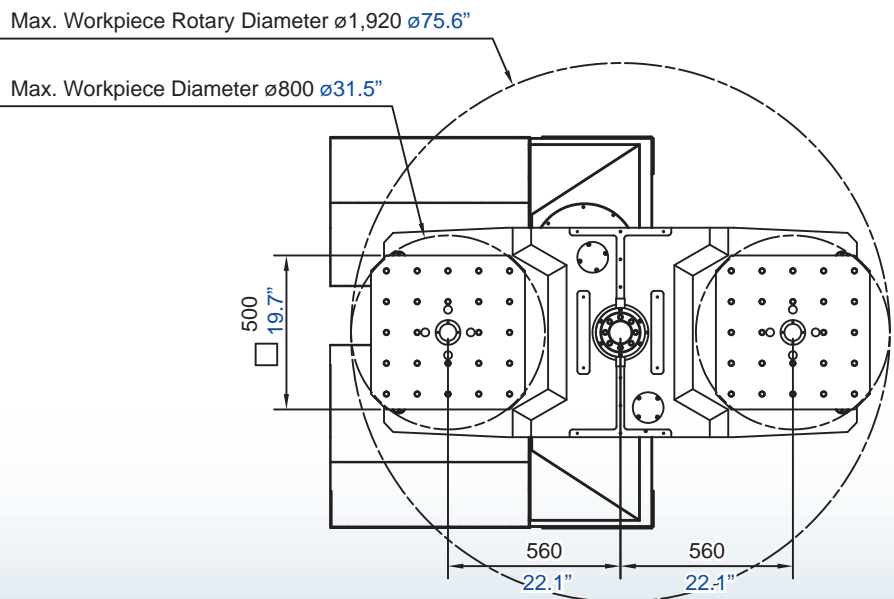

Specifications

		NH 500A	
SPINDLE			
Spindle Speed (opt.)	15,000 rpm (20,000 rpm)		
Spindle Power (opt.)	37 kW (22.5 kW) 50 HP (30HP)		
Spindle Taper	BBT40		
TRAVEL			
X-axis Travel	800 mm 31.5"		
Y-axis Travel	730 mm 28.74"		
Z-axis Travel	800 mm 31.5"		
Distance between Spindle Center and Table Top	50~780 mm 1.96" ~ 30.71"		
Distance between Spindle Nose and Table Center	150~950 mm 5.91" ~ 31.4"		
Acceleration (X / Y / Z)	1g / 1g / 1g		
TABLE			
Table Size	500 mm x 500 mm 19.69" x 19.69"		
Max. Load on Table	500 kg 1,100 lb		
Table Configuration (PT x Number of Holes x Pitch)	M16 x 24 holes x 100 mm M16 x 24 holes x 3.94"		
Max. Work Dimensions (6PC)	ø880 x 1,000 mm (ø800 x 1,000 mm) ø34.64" x 39.37" (ø31.5" x 39.37")		
Table Indexing Angle (opt.)	1° (0.001°)		
APC Change Time	11 sec.		
FEEDRATE			
Rapid Feedrate (X / Y / Z)	60 / 60 / 60 m/min. 2,362 / 2,362 / 2,362 ipm		
Cutting Feedrate	1~40,000 mm/min. 1~1,575 ipm		
ACCURACY			
	ISO 10791-4	YCM*	
Axial Travel	Full Length		
Accuracy A (X / Y / Z)	0.025 / 0.025 / 0.025 mm 0.00098" / 0.00098" / 0.00098"	0.01 / 0.01 / 0.01 mm 0.0004" / 0.0004" / 0.0004"	
Repeatability R (X / Y / Z)	0.015 / 0.015 / 0.015 mm 0.0006" / 0.0006" / 0.0006"	0.007 / 0.007 / 0.007 mm 0.0003" / 0.0003" / 0.0003"	
*All values shown above are measured for the machine in good air-conditioned environments.			
ATC			
Tool Magazine Capacity (opt.)	60T (120T)		
Max. Tool Weight (per piece)	10 kg 22 lb		
Max. Tool Dimensions (w/o adjacent tools)	ø80 x 400 (ø160 x 400) mm ø3.15" x 15.75" (ø6.3" x 15.8")		
GENERAL			
Pneumatic Supplier	5.5 kg/cm ² 78.2psi		
Machine Weight (opt.)	13,490 kg (14,390 kg) 29,740 lb (31,724 lb)		

Note: Above specifications may vary depending on the machine and the surrounding environment. The manufacturer reserves the right to modify the design, specifications, mechanisms, etc., to improve the performance of the machine without notice. The test data provided in this catalog is performed under specific test procedures and environmental conditions.

Accessories

● : Standard ○ : Option

	NH 500A
Tool Kit / Work Lamp / Pilot Lamp	●
Coolant Gun	●
Air Gun	●
Coolant Equipment System	●
Cutting Air Blast	●
Spindle Air Blast	●
Spindle Air Seal	●
Oil Skimmer	●
CTS (Coolant through Spindle) (20 Bar)	●
CTS (Coolant through Spindle) (70 Bar)	○
Spindle Cooling System	●
Circular Coolant Nozzle	●
Heavy Duty Coolant Pump	●
Chip Conveyor (Chain Type)	●
Dual-Chip Augers	●
Guideway Cover (X / Y / Z)	●
Safety Door	●
Heat Exchanger for Electrical Cabinet	●
A/C. Cooler for Electrical Cabinet	○
Mechanical, Electrical and Operating Manuals	●
Foundation Bolts	●
Optical Scale (X,Y,Z)	○
Optical Scale on B Axis	○
B-Axis Rotary Table (0.001°)	○
Auto Tool Length Measurement System	○
Automatic Workpiece Measurement System	○
Oil-mist Collector	○
Full Chip Enclosure	●
120T Tool Magazine	○
CE	○
CNC Control : MXP-200FB	●

Note: Above specifications may vary depending on the machine and the surrounding environment. The manufacturer reserves the right to modify the design, specifications, mechanisms, etc., to improve the performance of the machine without notice.

MXP-200 FA / FB

YCM CONTROL
by FANUC

- High Response AC Digital Servo & Spindle Drives with High Definition
- AICC II High Speed High Accuracy with Manual / Auto Switching on/off Machining
- JERK Control Function (MXP-200 FA opt.)
- High Rigidity Tapping, Helical Interpolation
- Custom Marco B and Tool Path Graphics
- Manual Guide i with large Screen Display .
- Program File Management for Easy Program Classifying
- USB Interface for Easy Parameters & CNC Programs Transfer
- 512KB Memory
- High Speed Positioning Function (opt.)
- Memory Card Program Edit & Operation
- NANO Smoothing Function (opt.)
- 400 Pairs Tool Offset, 400 Total Registered Programs
- 48 Pairs of Workpieces Coordinate System
- Extended Parts Program Editing (Cut, Copy, and Paste. Maximum 4,000 Characters)

i-Direct A remote monitoring system

The YCM Production Line Monitoring System i-Direct overcomes the limitations of time and distance. This software provides plant operators with instant production status, including production value, output, standby, alarm time, status display and malfunction records of the machine. These data could be browsed online and printed. When incidents occur, i-Direct will automatically warn plant operators through e-mail or MMS message. With i-Direct Production Line Monitoring System the plant operators can easily keep track of production statuses regardless of time and distance.



Intelligent Production Management



Machine Status Diagram



Factory Alarm Analysis



Shop Floor Reporting

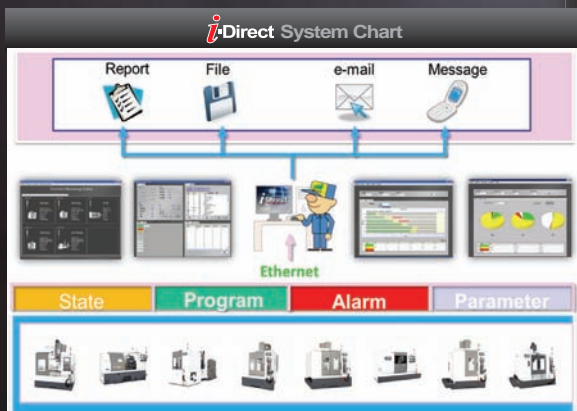

Machine Status History



Work Time Chart

i-OPERATION *Plus II*

Software Enhancement Exclusively from YCM



Pre-machining Preparation

Tool Length Measurement
Graphic measuring interface provides automatic tool length measurement function

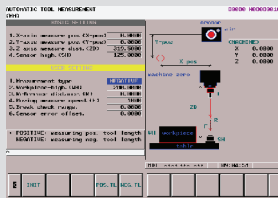

Workpiece Coordinate Calculation
Conversational operating window provides convenient and fast setup of workpiece coordinates

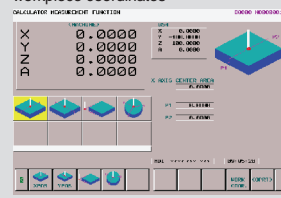

NEW RENISHAW GUI System (Conversational Graphic Operating Interface)

Tool measurement & measurement correction



Workpiece measurement



Programming

NEW I-PATTERN

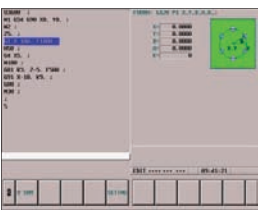

15 sets of machining cycle program
Reduces program input and memory time
Graphic interface & conversational command input

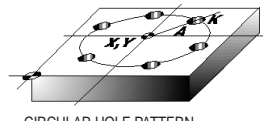

CIRCULAR HOLE PATTERN
(G120 P1) Function

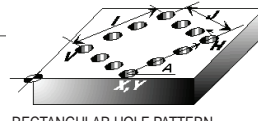

RECTANGULAR HOLE PATTERN
(G120 P4) Function

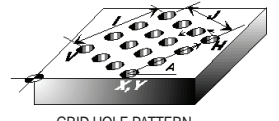

GRID HOLE PATTERN
(G120 P5) Function

Machining

High Performance Machining Mode M300

With 5 sets of parameter settings, the users choose the most suitable mode for optimum machining

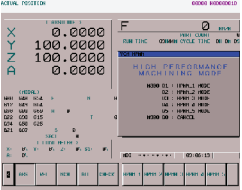

High Speed Machining Mode M400

Increases drilling and tapping speed, reduces machining time for job shop and precision mold machining

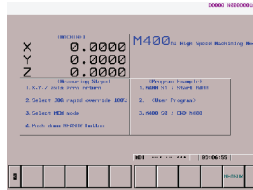

NEW Tool Load Management

Instant tool load monitoring with alarm function

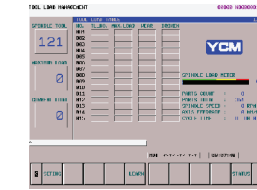

Multi-display Function

Displays 4 statuses simultaneously with configurable status display

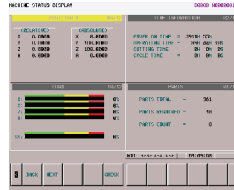

NEW Tool Life Management

Indicates tool status of each group with tool life alert

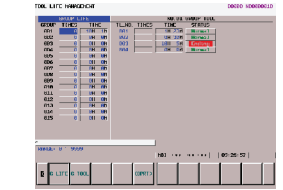

Instant Message Alert

Pop-up Alarm Display

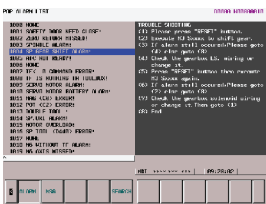

Instantly provides troubleshooting procedure
Quick response to alarm

Smart control panel (iPANEL)

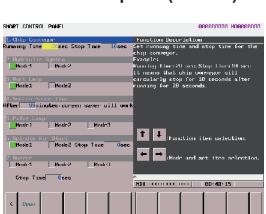

Easy to set up and operate important functions

Maintenance

Intelligent Maintenance

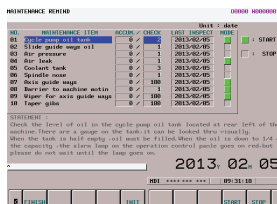

Provide users with periodic maintenance options and descriptions

Instantly provide users with maintenance notifications

Counter Function

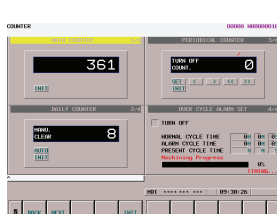

Allow users to keep count of workpieces with the function of overtime cycle alarm provides easy control over machining cycle time

1. Main Counter
2. Periodical Counter
3. Daily Counter
4. Over Cycle Alarm