

# BEMATO®

## CONVENTIONAL LATHE



# BEMATO®

STRIVING FOR SERVICE  
AND SATISFACTION

SINCE 1976

**BENIGN ENTERPRISE CO., LTD.**

SUITE 4, 5F., NO. 20, TA-LONG ROAD, TAICHUNG, TAIWAN R.O.C.

TEL: +886-4-23233016

FAX: +886-4-23232826 / +886-4-23238341

E-mail: [service@e-bemato.com](mailto:service@e-bemato.com)

<http://www.e-bemato.com>



STRIVING FOR SERVICE  
AND SATISFACTION

# COMPANY PROFILE



COMPANY NAME	: BENIGN ENTERPRISE CO., LTD.
ADDRESS	: SUITE 4, 5F., NO.20, TA-LONG ROAD, TAICHUNG, TAIWAN
TEL	: +886-4-23233016
FAX	: +886-4-23232826, 23238341
E-MAIL	: service@e-bemato.com
WEBSITE:	: www.e-bemato.com
REGISTERED TRADEMARK	: BEMATO
COMPANY ESTABLISHED	: 1976
CAPITAL	: US\$2,000,000.00
EMPLOYEE	: 25 (Includes 4 QC inspectors)
GENERAL MANAGER	: MR. DAVID WU
MAIN ACTIVITY	: 1. EXPORT MACHINE TOOLS, MACHINE TOOLS ACCESSORIES, INDUSTRIAL SUPPLIES, PNEUMATIC TOOLS AND OEM COMPONENTS 2. PURCHASING AGENT FOR FOREIGN COMPANIES 3. SHIPMENTS CONSOLIDATION
MAIN EXPORT MARKETS	: 1. EUROPE 2. NORTH AMERICA 3. MIDDLE & SOUTH AMERICA 4. AUSTRALIA & N.Z. 5. ASIA 6. SOUTH AFRICA
MAIN EXPORT PRODUCTS	: <u>A) MACHINE TOOLS</u> 1. LATHES (CNC & CONVENTIONAL) 2. MILLING MACHINES (CNC & CONVENTIONAL) 3. MACHINING CENTERS (VERTICAL & HORIZONTAL) 4. GRINDING MACHINES (SURFACE, CYLINDRICAL, INTERNAL, CENTERLESS, TOOL & CUTTER) 5. SAWING MACHINES (HORIZONTAL, VERTICAL, & CIRCULAR) 6. DRILLING MACHINES (BENCH, FLOOR, RADIAL, NC, VERTICAL & HORIZONTAL) 7. WOODWORKING MACHINES (DIY & INDUSTRIAL) 8. WIRE CUT & EDM (DIE SINKER, MICRO DRILL) 9. SHEET METAL MACHINES (SHEAR, PRESS BRAKE, FOLDING, BENDING, ROLLING) 10. SPECIAL MACHINES, OEM COMPONENTS (STAMPING, PLASTIC INJECTION, ALUMINUM EXTRUSION, CASTINGS, ETC.)  <u>B) MACHINE TOOLS ACCESSORIES &amp; INDUSTRIAL TOOLS &amp; SUPPLIES</u>  <u>C) PNEUMATIC TOOLS</u>

## CONVENTIONAL LATHE

1. SWING OVER BED 305 MM	P.1
2. SWING OVER BED 330 MM	P.3
3. SWING OVER BED 342 MM & 356 MM	P.5
4. SWING OVER BED 360 MM	P.7
5. SWING OVER BED 380 MM & 390 MM	P.9
6. SWING OVER BED 400 MM & 410 MM	P.11
7. SWING OVER BED 430 MM & 432 MM	P.13
8. SWING OVER BED 434 MM & 440 MM	P.15
9. SWING OVER BED 460 MM	P.17
10. SWING OVER BED 462 MM	P.19
11. SWING OVER BED 470 MM	P.21
12. SWING OVER BED 508 MM & 510 MM	P.23
13. SWING OVER BED 520 MM	P.25
14. SWING OVER BED 540 MM & 542 MM	P.27
15. SWING OVER BED 560 MM	P.29
16. SWING OVER BED 600 MM	P.31
17. SWING OVER BED 610 MM & 630 MM	P.33
18. SWING OVER BED 660 MM	P.35
19. SWING OVER BED 670 MM	P.37
20. SWING OVER BED 760 MM	P.39
21. SWING OVER BED 770 MM	P.41

## HEAVY DUTY CONVENTIONAL LATHE

22. SWING OVER BED 830 MM & 840 MM	P.43
23. SWING OVER BED 860 MM & 880 MM	P.45
24. SWING OVER BED 960 MM	P.47
25. SWING OVER BED 1060 MM	P.49
26. SWING OVER BED 1010 MM & 1135 MM	P.51
27. SWING OVER BED 1165 MM ~ 1200 MM	P.53
28. SWING OVER BED 1275 MM & 1280 MM	P.55
29. SWING OVER BED 1300 MM & 1340 MM	P.57
30. SWING OVER BED 1530 MM ~ 1600 MM	P.59
31. SWING OVER BED 1800 MM & 1805 MM	P.61
32. SWING OVER BED 2000 MM & 2050 MM	P.63
33. SWING OVER BED 2250 MM & 2290 MM	P.65
34. SWING OVER BED 2500 MM ~ 2700 MM	P.67
35. SWING OVER BED 3060 MM & 3560 MM	P.69

## 1. SWING OVER BED 305 MM



◀ **BMT 1216GH  
BMT 1224GH  
BMT 1236GH**

▼ **BMT 1224BV / BMT 1236BV**



· Machines shown with optional accessories.



▲ **Headstock & Gearbox**



▲ **End gear train & Sensor**

### SPECIFICATION:

Description	BMT 1216GH	BMT 1224GH	BMT 1236GH	BMT 1224BV	BMT 1236BV
Swing over bed		305 mm			306 mm
Swing over cross slide		170 mm			186 mm
Swing over gap				445 mm	
Center height		152.5 mm			153 mm
Distance between centers	406 mm	610 mm	915 mm	610 mm	915 mm
Bed width			190 mm		
Compound rest travel		100 mm			92 mm
Cross slide travel		170 mm			168 mm
Spindle nose			D1-4		
Spindle bore			40 mm		
Taper of spindle bore			MT 5		
Spindle speed		12 steps / 70~1500 rpm			Vari. speeds / 40~2000 rpm
Taper of tailstock			MT 3		
Tailstock quill travel		100 mm			95 mm
Tailstock quill diameter			40 mm		
Main motor		1.5 HP/1 PH / 2 HP/3 PH			2 HP
Coolant pump motor			1/8 HP		
Machine size (L x W x H)	1126 x 730 x 518 mm	1330 x 730 x 518 mm	1635 x 730 x 518 mm	1335 x 717 x 1150 mm	1640 x 717 x 1150 mm
Machine packing size (L x W x H)	1270 x 760 x 760 mm	1473 x 760 x 760 mm	1780 x 760 x 760 mm	1500 x 762 x 1550 mm	1800 x 762 x 1550 mm
Net weight (approx.)	260 kgs	280 kgs	300 kgs	500 kgs	550 kgs
Gross weight (approx.)	320 kgs	340 kgs	360 kgs	620 kgs	670 kgs

\*Specifications are subject to change without prior notice.

#### BMT 1216GH / BMT 1224GH / BMT 1236GH

- |  |   |
|--|---|
| <ul style="list-style-type: none"> <li>· 3-jaw 6" scroll chuck</li> <li>· 4-jaw 8" independent chuck</li> <li>· Back plate &amp; Face plate</li> <li>· Steady rest &amp; Follow rest</li> <li>· 4-way toolpost</li> <li>· Motor &amp; motor pulley</li> <li>· Dead center &amp; center sleeve</li> <li>· Change gears</li> <li>· Tools &amp; tool box</li> </ul> | <ul style="list-style-type: none"> <li>· 5C collet attachment</li> <li>· Taper turning attachment</li> <li>· Quick change toolpost</li> <li>· Micrometer carriage stop</li> <li>· 4-position carriage stop</li> <li>· Rear splash guard</li> <li>· Chuck guard</li> <li>· Floor stand</li> <li>· Drill chuck with arbor</li> <li>· Coolant system</li> <li>· Work light</li> <li>· CE standard</li> </ul> |
|--|---|

#### BMT 1224BV / BMT 1236BV

- |  |  |
|--|--|
| <ul style="list-style-type: none"> <li>· Back plate</li> <li>· Steady rest</li> <li>· 4-way toolpost</li> <li>· Main motor with inverter</li> <li>· Thread dial indicator</li> <li>· Changer gears</li> <li>· Dead center &amp; center sleeve</li> <li>· Leveling pads</li> <li>· Foot brake &amp; emergency stop</li> <li>· Splash guard</li> <li>· Coolant system &amp; chip tray</li> <li>· Tools &amp; tool box</li> </ul> | <ul style="list-style-type: none"> <li>· 3-jaw &amp; 4-jaw chuck</li> <li>· Face plate</li> <li>· Follow rest</li> <li>· 5C collet attachment</li> <li>· Taper turning attachment</li> <li>· Quick change toolpost</li> <li>· Micrometer carriage stop</li> <li>· 4-position carriage stop</li> <li>· Live center</li> <li>· Drill chuck &amp; arbor</li> <li>· Chuck guard</li> <li>· Toolpost guard</li> <li>· Digital readout</li> <li>· Halogen lamp</li> <li>· CE &amp; CSA standard</li> </ul> |
|--|--|

# CONVENTIONAL LATHE



## 2.SWING OVER BED 330 MM

▼ BMT 1324E / BMT 1340E



▼ BMT 1330T / BMT 1340T

▼ BMT 1330SM / BMT 1340SM



### SPECIFICATION:

Description	BMT 1324E	BMT 1330P	BMT 1330SM BMT 1330SMV	BMT 1330AS BMT 1330ASL BMT 1330ASV
Swing over bed	330 mm			
Swing over cross slide	195 mm	190 mm	195 mm	
Swing over gap	490 mm	510 mm	490 mm	
Center height	165 mm			
Distance between centers	600 mm	750 mm		
Bed width	190 mm	185 mm	190 mm	206 mm
Compound rest travel	100 mm	95 mm		
Cross slide travel	165 mm	145 mm	160.5 mm	157 mm
Spindle nose	D1-4			
Spindle bore	40 mm	35 mm	38 mm	
Taper of spindle bore	MT 5	MT 4	MT 5	
Spindle speed	9 steps / 82~2000 rpm	8 steps / 105~2000 rpm Vari. speeds / 40~2500 rpm (opt.)	12 steps / 45~1800 rpm Vari. speeds / 30~2000 rpm	8 steps / 90~1800 rpm Vari. speeds / 30~2200 rpm
Taper of tailstock	MT 3			
Tailstock quill travel	100 mm	95 mm		110 mm
Tailstock quill diameter	40 mm		45 mm	
Main motor	2 HP / 1 PH 3 HP / 3 PH (opt.)	3 HP		
Coolant pump motor	1/8 HP			
Machine size (L x W x H)	1230 x 720 x 1150 mm	1550 x 724 x 1175 mm	1685 x 736 x 1175 mm 1685 x 736 x 1298 mm	1660 x 740 x 1180 mm 1660 x 852 x 1298 mm
Machine packing size (L x W x H)	1473 x 762 x 1473 mm	1625 x 760 x 1473 mm	1700 x 762 x 1550 mm	1700 x 762 x 1550 mm
Net weight (approx.)	580 kgs	620 kgs	650 kgs / 700 kgs	650 kgs
Gross weight (approx.)	660 kgs	750 kgs	770 kgs / 820 kgs	770 kgs

\*Specifications are subject to change without prior notice.

BMT 1324E / BMT 1340E
<ul style="list-style-type: none"> <li>STANDARD ACCESSORIES</li> <li>3-jaw 6" scroll chuck</li> <li>4-jaw 8" independent chuck</li> <li>Back plate &amp; Face plate</li> <li>Steady rest &amp; Follow rest</li> <li>4-way toolpost</li> <li>Motor &amp; electric control system</li> <li>Dead center &amp; center sleeve</li> <li>Rapid foot brake</li> <li>Thread dial indicator</li> <li>Gap bed</li> <li>Change gears</li> <li>Dual dials</li> <li>Rear splash guard</li> <li>Coolant system</li> <li>Tools &amp; tool box</li> </ul>
<ul style="list-style-type: none"> <li>OPTIONAL ACCESSORIES</li> <li>Live center</li> <li>Drill chuck with arbor</li> <li>Chuck guard</li> <li>Micrometer carriage stop</li> <li>4-position carriage stop</li> <li>Milling attachment</li> <li>Taper turning attachment</li> <li>Quick change toolpost</li> <li>Single toolpost</li> <li>Digital readout</li> <li>Work lamp</li> <li>CE &amp; CSA standard</li> </ul>

BMT 1330P / BMT 1340P	
<ul style="list-style-type: none"> <li>STANDARD ACCESSORIES</li> <li>Back plate</li> <li>4-way toolpost</li> <li>Motor &amp; electric control system</li> <li>Thread dial indicator</li> <li>Low voltage control system</li> <li>Dead center &amp; center sleeve</li> <li>Leveling pads</li> <li>Coolant system</li> <li>Tools &amp; tool box</li> </ul>	<ul style="list-style-type: none"> <li>OPTIONAL ACCESSORIES</li> <li>3-jaw &amp; 4-jaw chuck</li> <li>Face plate</li> <li>Steady rest &amp; Follow rest</li> <li>Gap bed</li> <li>5C collet attachment</li> <li>Taper turning attachment</li> <li>Quick change toolpost</li> <li>Chuck guard</li> <li>Chip guard</li> <li>Full length splash guard</li> <li>Micrometer carriage stop</li> <li>Two-speed motor</li> <li>Leadscrew cover</li> <li>Electromagnetic brake</li> <li>Live center</li> <li>Universal gear box</li> <li>LED lamp</li> <li>CE &amp; CSA standard</li> </ul>

BMT 1336GH / BMT 1340GH	
<ul style="list-style-type: none"> <li>STANDARD ACCESSORIES</li> <li>3-jaw 6" scroll chuck</li> <li>4-jaw 8" independent chuck</li> <li>Back plate &amp; Face plate</li> <li>Steady rest &amp; Follow rest</li> <li>4-way toolpost</li> <li>Motor &amp; motor pulley</li> <li>Dead center &amp; center sleeve</li> <li>Change gears</li> <li>Tools &amp; tool box</li> </ul>	<ul style="list-style-type: none"> <li>OPTIONAL ACCESSORIES</li> <li>5C collet attachment</li> <li>Taper turning attachment</li> <li>Quick change toolpost</li> <li>Micrometer carriage stop</li> <li>4-position carriage stop</li> <li>Rear splash guard</li> <li>Chuck guard</li> <li>Floor stand</li> <li>Drill chuck with arbor</li> <li>Coolant system</li> <li>Work light</li> <li>CE standard</li> </ul>

▼ BMT 1330AS / BMT 1340AS  
BMT 1330ASV / BMT 1340ASV



▼ BMT 1330ASL  
BMT 1340ASL



▼ BMT 1336GH  
BMT 1340GH



▼ BMT 1340BV



### SPECIFICATION:

Description	BMT 1336GH	BMT 1340GH	BMT 1340E	BMT 1340P	BMT 1340SM BMT 1340SMV	BMT 1340AS BMT 1340ASL BMT 1340ASV	BMT 1340BV
Swing over bed	330 mm						
Swing over cross slide	195 mm		190 mm	195 mm	195 mm	210 mm	
Swing over gap	480 mm	490 mm		510 mm	490 mm	470 mm	
Center height	165 mm						
Distance between centers	915 mm	1000 mm					
Bed width	190 mm			185 mm	190 mm	206 mm	190 mm
Compound rest travel	100 mm				95 mm		92 mm
Cross slide travel	170 mm	165 mm		145 mm	160.5 mm	157 mm	168 mm
Spindle nose	D1-4						
Spindle bore	40 mm			35 mm	38 mm		40 mm
Taper of spindle bore	MT 5			MT 4	MT 5		
Spindle speed	12 steps / 70~1500 rpm		9 steps / 82~2000 rpm	8 steps / 105~2000 rpm Vari. speeds / 40~2500 rpm (opt.)	12 steps / 45~1800 rpm Vari. speeds / 30~2000 rpm	8 steps / 90~1800 rpm Vari. speeds / 30~2200 rpm	Vari. speeds / 40~2000 rpm
Taper of tailstock	MT 3						
Tailstock quill travel	100 mm				95 mm	110 mm	95 mm
Tailstock quill diameter	40 mm					45 mm	40 mm
Main motor	1.5 HP / 1 PH or 2 HP / 3 PH		2 HP / 1 PH 3 HP / 3 PH (opt.)	3 HP			
Coolant pump motor	1/8 HP						
Machine size (L x W x H)	1635 x 730 x 518 mm	1720 x 730 x 518 mm	1460 x 720 x 1150 mm	1800 x 724 x 1175 mm	1935 x 736 x 1175 mm 1935 x 829 x 1318 mm	1920 x 740 x 1180 mm 1920 x 852 x 1298 mm	1885 x 717 x 1163 mm
Machine packing size (L x W x H)	1780 x 760 x 760 mm	1855 x 760 x 760 mm	1855 x 762 x 1473 mm	1930 x 760 x 1473 mm	1960 x 762 x 1550 mm	1960 x 762 x 1550 mm	1905 x 762 x 1550 mm
Net weight (approx.)	310 kgs	320 kgs	600 kgs	670 kgs	650 kgs / 700 kgs	700 kgs	600 kgs
Gross weight (approx.)	370 kgs	390 kgs	660 kgs	820 kgs	770 kgs / 820 kgs	820 kgs	720 kgs

\*Specifications are subject to change without prior notice.

BMT 1330SM / BMT 1330SMV BMT 1340SM / BMT 1340SMV	
<ul style="list-style-type: none"> <li>STANDARD ACCESSORIES</li> <li>Back plate</li> <li>4-way toolpost</li> <li>Motor &amp; electric control system</li> <li>Thread dial indicator</li> <li>Low voltage control system</li> <li>Dead center &amp; center sleeve</li> <li>Leveling pads</li> <li>Coolant system</li> <li>Tools &amp; tool box</li> </ul>	<ul style="list-style-type: none"> <li>OPTIONAL ACCESSORIES</li> <li>3-jaw &amp; 4-jaw chuck</li> <li>Face plate</li> <li>Follow rest</li> <li>5C collet attachment</li> <li>Taper turning attachment</li> <li>Quick change toolpost</li> <li>Micrometer carriage stop</li> <li>4-position carriage stop</li> <li>Live center</li> <li>Drill chuck &amp; arbor</li> <li>Chuck guard</li> <li>Toolpost guard</li> <li>Electromagnetic brake</li> <li>Digital readout</li> <li>Halogen lamp</li> <li>CE &amp; CSA standard</li> </ul>

BMT 1330AS / BMT 1330ASL / BMT 1330ASV BMT 1340AS / BMT 1340ASL / BMT 1340ASV	
<ul style="list-style-type: none"> <li>STANDARD ACCESSORIES</li> <li>Back plate</li> <li>Steady rest</li> <li>4-way toolpost</li> <li>Main motor</li> <li>Thread dial indicator</li> <li>Change gears</li> <li>Dead center &amp; center sleeve</li> <li>Leveling pads</li> <li>Splash guard</li> <li>Foot brake &amp; emergency stop</li> <li>Universal gear box</li> </ul>	<ul style="list-style-type: none"> <li>OPTIONAL ACCESSORIES</li> <li>3-jaw &amp; 4-jaw chuck</li> <li>Face plate</li> <li>Follow rest</li> <li>2 speed motor (3PH ONLY)</li> <li>Enlarged motor</li> <li>Electromagnetic brake</li> <li>Universal gear box</li> <li>5C collet attachment</li> <li>Taper turning attachment</li> <li>Quick change toolpost</li> <li>Micrometer carriage stop</li> <li>4-position carriage stop</li> <li>Live center</li> <li>Drill chuck &amp; arbor</li> <li>Chuck guard</li> <li>Toolpost guard</li> <li>Digital readout</li> <li>Halogen lamp</li> <li>CE &amp; CSA standard</li> </ul>

BMT 1340BV	
<ul style="list-style-type: none"> <li>STANDARD ACCESSORIES</li> <li>Back plate</li> <li>Steady rest</li> <li>4-way toolpost</li> <li>Main motor with inverter</li> <li>Thread dial indicator</li> <li>Changer gears</li> <li>Dead center &amp; center sleeve</li> <li>Leveling pads</li> <li>Foot brake &amp; emergency stop</li> <li>Splash guard</li> <li>Coolant system &amp; chip tray</li> <li>Tools &amp; tool box</li> </ul>	<ul style="list-style-type: none"> <li>OPTIONAL ACCESSORIES</li> <li>3-jaw &amp; 4-jaw chuck</li> <li>Face plate</li> <li>Follow rest</li> <li>5C collet attachment</li> <li>Taper turning attachment</li> <li>Quick change toolpost</li> <li>Micrometer carriage stop</li> <li>4-position carriage stop</li> <li>Live center</li> <li>Drill chuck &amp; arbor</li> <li>Chuck guard</li> <li>Toolpost guard</li> <li>Digital readout</li> <li>Halogen lamp</li> <li>CE &amp; CSA standard</li> </ul>

# CONVENTIONAL LATHE



## 3. SWING OVER BED 342 MM & 356 MM

### ▼ BMT 1330ER / BMT 1340ER



### ▼ BMT 1430SM / BMT 1440SM



· Machines shown with optional accessories.

### ▼ BMT 1430AS / BMT 1440AS BMT 1430ASV / BMT 1440ASV

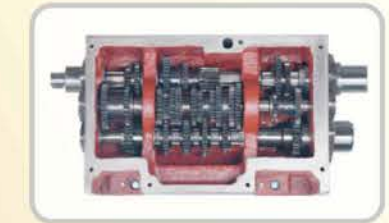

▲ Universal type gear box

· Machines shown with optional accessories.

#### SPECIFICATION:

Description	BMT 1330ER BMT 1330ERV	BMT 1340ER BMT 1340ERV	BMT 1430SM BMT 1430SMV	BMT 1430AS BMT 1430ASL BMT 1430ASV	BMT 1440SM BMT 1440SMV	BMT 1440AS BMT 1440ASL BMT 1440ASV
Swing over bed	342 mm		356 mm			
Swing over cross slide	205 mm		220 mm			
Swing over gap	512 mm		515 mm			
Center height	171 mm		178 mm			
Distance between centers	760 mm	1000 mm	750 mm		1000 mm	
Bed width	230 mm		190 mm	206 mm	190 mm	206 mm
Compound rest travel	100 mm		95 mm	101 mm	95 mm	101 mm
Cross slide travel	180 mm		160.5 mm	167 mm	160.5 mm	167 mm
Spindle nose	D1-4					
Spindle bore	40 mm		38 mm			
Taper of spindle bore	MT 5					
Spindle speed	8 steps / 80~2000 rpm		12 steps / 45~1800 rpm	8 steps / 90~1800 rpm	12 steps / 45~1800 rpm	8 steps / 90~1800 rpm
	Vari. speeds / 100~3000 rpm		Vari. speeds / 30~2000 rpm	Vari. speeds / 30~2200 rpm	Vari. speeds / 30~2000 rpm	Vari. speeds / 30~2200 rpm
Taper of tailstock	MT 3					
Tailstock quill travel	112 mm		95 mm	110 mm	95 mm	110 mm
Tailstock quill diameter	50 mm		40 mm	45 mm	40 mm	45 mm
Main motor	3 HP / 5 HP (opt.)		3 HP			
Coolant pump motor	1/8 HP					
Machine size (L x W x H)	1800 x 790 x 1215 mm	2100 x 790 x 1215 mm	1685 x 736 x 1200mm	1660 x 740 x 1194 mm	1935 x 736 x 1200 mm	1920 x 740 x 1194 mm
	1800 x 900 x 1380 mm	2100 x 900 x 1380 mm	1685 x 852 x 1318mm	1660 x 740 x 1194 mm 1660 x 852 x 1298 mm	1685 x 852 x 1318 mm	1920 x 740 x 1194 mm 1920 x 852 x 1298 mm
Machine packing size (L x W x H)	2000 x 965 x 1745 mm		2270 x 965 x 1745 mm		1700 x 762 x 1550 mm	
Net weight (approx.)	850 kgs		1000 kgs		700 kgs	
Gross weight (approx.)	1000 kgs		1200 kgs		830 kgs	

\*Specifications are subject to change without prior notice.

#### BMT 1330ER / BMT 1330ERV BMT 1340ER / BMT 1340ERV

- |  |   |
|--|---|
| <ul style="list-style-type: none"> <li>■ STANDARD ACCESSORIES</li> <li>· Z axis stop set</li> <li>· Back plate</li> <li>· Steady rest &amp; Follow rest</li> <li>· Splash guard</li> <li>· Dead center &amp; center sleeve</li> <li>· Leveling pads</li> <li>· Halogen lamp</li> <li>· Tools &amp; tool box</li> </ul> | <ul style="list-style-type: none"> <li>■ OPTIONAL ACCESSORIES</li> <li>· 3-jaw &amp; 4-jaw chuck</li> <li>· Face plate</li> <li>· 5C collets &amp; collet attachment</li> <li>· 16 steps speed motor</li> <li>· Quick change toolpost</li> <li>· Taper turning attachment</li> <li>· Hydraulic copying attachment</li> <li>· Micrometer carriage stop</li> <li>· Drill chuck &amp; arbor</li> <li>· Chuck safety guard</li> <li>· Digital readout</li> <li>· CE standard</li> </ul> |
|--|---|

#### BMT 1430SM / BMT 1430SMV / BMT 1440SM / BMT 1440SMV BMT 1430AS / BMT 1430ASL / BMT 1430ASV BMT 1440AS / BMT 1440ASL / BMT 1440ASV

- |   |  |
|---|--|
| <ul style="list-style-type: none"> <li>■ STANDARD ACCESSORIES</li> <li>· Back plate</li> <li>· Steady rest</li> <li>· 4-way toolpost</li> <li>· Main motor</li> <li>· Thread dial indicator</li> <li>· Change gears</li> <li>· Dead center &amp; center sleeve</li> <li>· Leveling pads</li> <li>· Splash guard</li> <li>· Foot brake &amp; emergency stop</li> <li>· Universal gear box for BMT 1430ASL &amp; BMT 1440ASL</li> <li>· Coolant system &amp; chip tray</li> <li>· Tools &amp; tool box</li> </ul> | <ul style="list-style-type: none"> <li>■ OPTIONAL ACCESSORIES</li> <li>· 3-jaw &amp; 4-jaw chuck</li> <li>· Face plate</li> <li>· Follow rest</li> <li>· Enlarged motor except BMT 1430SM, BMT 1430SMV, BMT 1440SM &amp; BMT 1440SMV</li> <li>· Electromagnetic brake</li> <li>· 5C collet attachment</li> <li>· Taper turning attachment</li> <li>· Quick change toolpost</li> <li>· Micrometer carriage stop</li> <li>· 4-position carriage stop</li> <li>· Live center</li> <li>· Drill chuck &amp; arbor</li> <li>· Chuck guard</li> <li>· Toolpost guard</li> <li>· Digital readout</li> <li>· Halogen lamp</li> <li>· CE &amp; CSA standard</li> </ul> |
|---|--|

# CONVENTIONAL LATHE



## 4. SWING OVER BED 360 MM

### ▼ BMT 1430S / BMT 1440S



### ▼ BMT 1440E



· Machines shown with optional accessories.

#### SPECIFICATION:

Description	BMT 1430S	BMT 1440E	BMT 1440TS	BMT 1440VE
Swing over bed	360 mm			
Swing over cross slide	215 mm		225 mm	
Swing over gap	560 mm		520 mm	
Center height	178 mm		180 mm	
Distance between center	750 mm		1000 mm	
Bed width	250 mm	190 mm		230 mm
Compound rest travel	100 mm			96 mm
Cross slide travel	195 mm	165 mm		180 mm
Spindle nose	D1-5		D1-4	
Spindle bore	42 mm		40 mm	
Taper of spindle bore	MT 5			
Spindle speed	8 steps / 70~2000 rpm Vari. speeds / 35~2500 rpm (opt.)	9 steps / 82~2000 rpm	12 steps / 50~2000 rpm	Vari. speeds / 36~2200 rpm
Taper of tailstock	MT 3			
Tailstock quill travel	120 mm		100 mm	
Tailstock quill diameter	50 mm		40 mm	
Main motor	5 HP	2HP/1PH / 3HP/3PH (opt.)		5 HP
Coolant pump motor	1/8 HP			
Machine size (L x W x H)	1610 x 888 x 1223 mm	1460 x 720 x 1165 mm		1849 x 800 x 1297 mm
Machine packing size (L x W x H)	1830 x 915 x 1525 mm	1855 x 762 x 1473 mm		1930 x 813 x 1600 mm
Net weight (approx.)	850 kgs	620 kgs		720 kgs
Gross weight (approx.)	1000 kgs	680 kgs		800 kgs

\*Specifications are subject to change without prior notice.

#### BMT 1430S / BMT 1440S

- |  |  |
|--|--|
| <ul style="list-style-type: none"> <li>STANDARD ACCESSORIES</li> <li>· Back plate</li> <li>· 4-way toolpost</li> <li>· Motor &amp; electric control system</li> <li>· Thread dial indicator</li> <li>· Low voltage control system</li> <li>· Dead center &amp; center sleeve</li> <li>· Leveling pads</li> <li>· Coolant system</li> <li>· Tools &amp; tool box</li> </ul> | <ul style="list-style-type: none"> <li>OPTIONAL ACCESSORIES</li> <li>· 3-jaw &amp; 4-jaw chuck</li> <li>· Face plate</li> <li>· Steady rest &amp; Follow rest</li> <li>· Gap bed</li> <li>· 5C collet attachment</li> <li>· Taper turning attachment</li> <li>· Quick change toolpost</li> <li>· Chuck guard</li> <li>· Chip guard</li> <li>· Full length splash guard</li> <li>· One-shot lubrication system</li> <li>· 2 speed motor</li> <li>· Electromagnetic brake</li> <li>· Micrometer carriage stop</li> <li>· Leadscrew cover</li> <li>· Live center</li> <li>· Digital readout</li> <li>· CE &amp; CSA standard</li> </ul> |
|--|--|

#### BMT 1440E / BMT 1440VE / BMT 1440TS

- |  |   |
|--|---|
| <ul style="list-style-type: none"> <li>STANDARD ACCESSORIES</li> <li>· 3-jaw 6" scroll chuck</li> <li>· 4-jaw 8" independent chuck</li> <li>· Back plate &amp; Face plate</li> <li>· Steady rest &amp; Follow rest</li> <li>· 4-way toolpost</li> <li>· Motor &amp; electric control system</li> <li>· Dead center &amp; center sleeve</li> <li>· Rapid foot brake</li> <li>· Thread dial indicator</li> <li>· Gap bed</li> <li>· Change gears</li> <li>· Dual dials</li> <li>· Rear splash guard</li> <li>· Coolant system</li> <li>· Tools &amp; tool box</li> </ul> | <ul style="list-style-type: none"> <li>OPTIONAL ACCESSORIES</li> <li>· Live center</li> <li>· Drill chuck with arbor</li> <li>· Chuck guard</li> <li>· Micrometer carriage stop</li> <li>· 4-position carriage stop</li> <li>· Milling attachment</li> <li>· Taper turning attachment</li> <li>· Quick change toolpost</li> <li>· Single toolpost</li> <li>· Digital readout</li> <li>· Work lamp</li> <li>· CE &amp; CSA standard</li> </ul> |
|--|---|

### ▼ BMT 1440TS / BMT 1440VE



### ▼ BMT 1440RMV / BMT 1460RMV



· Machines shown with optional accessories.

#### SPECIFICATION:

Description	BMT 1440S	BMT 1440RM / 1440RMV	BMT 1460RM / 1460RMV
Swing over bed	360 mm		
Swing over cross slide	215 mm		212 mm
Swing over gap	560 mm		533 mm
Center height	178 mm		180 mm
Distance between center		1000 mm	1500 mm
Bed width	250 mm		260 mm
Compound rest travel	100 mm		130 mm
Cross slide travel	195 mm		220 mm
Spindle nose	D1-5		D1-6
Spindle bore	42 mm		52.5 mm
Taper of spindle bore	MT 5		MT 6
Spindle speed	8 steps / 70~2000 rpm Vari. speeds / 35~2500 rpm (opt.)		8 steps / 70~1800 rpm Vari. speeds / 20~2500 rpm
Taper of tailstock			MT 4
Tailstock quill travel	120 mm		152 mm
Tailstock quill diameter	50 mm		52 mm
Main motor	5 HP		
Coolant pump motor	1/8 HP		
Machine size (L x W x H)	1864 x 888 x 1223 mm	2080 x 900 x 1240 mm / 2080 x 990 x 1370 mm	2580 x 900 x 1240 mm / 2080 x 990 x 1370 mm
Machine packing size (L x W x H)	2135 x 915 x 1525 mm	2270 x 1120 x 1745 mm	2785 x 1120 x 1745 mm
Net weight (approx.)	900 kgs	1350 kgs	1450 kgs
Gross weight (approx.)	1100 kgs	1500 kgs	1600 kgs

\*Specifications are subject to change without prior notice.

#### BMT 1440RM / BMT 1440RMV BMT 1460RM / BMT 1460RMV

- |  |   |
|--|---|
| <ul style="list-style-type: none"> <li>STANDARD ACCESSORIES</li> <li>· Z axis stop set</li> <li>· Back plate</li> <li>· Steady rest &amp; Follow rest</li> <li>· Dead center &amp; center sleeve</li> <li>· Leveling pads</li> <li>· Full length splash guard</li> <li>· Halogen lamp</li> <li>· Tools &amp; tool box</li> </ul> | <ul style="list-style-type: none"> <li>OPTIONAL ACCESSORIES</li> <li>· 3-jaw &amp; 4-jaw chuck</li> <li>· Face plate</li> <li>· Driving plate</li> <li>· 5C collets</li> <li>· 5C collet attachment</li> <li>· 16 steps speed motor</li> <li>· Quick change toolpost</li> <li>· Taper turning attachment</li> <li>· Hydraulic copying attachment</li> <li>· Micrometer carriage stop</li> <li>· Chuck safety guard</li> <li>· Digital readout</li> <li>· CE standard</li> </ul> |
|--|---|

# CONVENTIONAL LATHE



## 5. SWING OVER BED 380 MM & 390 MM

▼ BMT 1540A / BMT 1560A



BMT 1540AV / BMT 1560AV ▼



▼ BMT 1550BH



· Machines shown with optional accessories.

▼ BMT 1530C / BMT 1540C / BMT 1550C



· Machines shown with optional accessories.

### SPECIFICATION:

Description	BMT 1540A BMT 1540AV	BMT 1550BH BMT 1550BHV	BMT 1560A BMT 1560AV	BMT 1530C	BMT 1540C	BMT 1550C
Swing over bed	380 mm			390 mm		
Swing over cross slide	225 mm	238 mm	225 mm	240 mm		
Swing over gap	580 mm	610 mm	580 mm	610 mm		
Center height	191 mm	190 mm	191 mm	190 mm		
Distance between centers	1000 mm	1250 mm	1500 mm	760 mm	1000 mm	1250 mm
Bed width	300 mm	280 mm	300 mm	270 mm		
Compound rest travel	235 mm	120 mm	235 mm	120 mm		
Cross slide travel	235 mm			230 mm		
Spindle nose	D1-6					
Spindle bore	58 mm	56 mm	58 mm	54 mm		
Taper of spindle bore	MT 6					
Spindle speed	12 steps / 20~2000 rpm	16 steps / 25~2000 rpm	12 steps / 20~2000 rpm	16 steps / 25~2000 rpm Vari. speeds / 18~2500 rpm (opt.)		
	Vari. speeds / 10~2000 rpm	Vari. speeds / 2~2500 rpm	Vari. speeds / 10~2000 rpm			
Taper of tailstock	MT 4					
Tailstock quill travel	125 mm	127 mm	125 mm	155 mm		
Tailstock quill diameter	58 mm			58.5 mm		
Main motor	7.5 HP					
Coolant pump motor	1/8 HP					
Machine size (L x W x H)	2300 x 985 x 1240 mm	2450 x 955 x 1235 mm	2810 x 985 x 1240 mm	1955 x 1031 x 1232 mm	2205 x 1031 x 1232 mm	2455 x 1031 x 1232 mm
	2300 x 985 x 1403 mm	2450 x 1075 x 1435 mm	2810 x 985 x 1403 mm			
Machine packing size (L x W x H)	2340 x 1170 x 1600 mm	2580 x 1120 x 1745 mm	2900 x 1170 x 1600 mm	1970 x 1016 x 1600 mm	2210 x 1016 x 1600 mm	2515 x 1016 x 1600 mm
Net weight (approx.)	1400 kgs	1450 kgs	1600 kgs	1000 kgs	1150 kgs	1300 kgs
Gross weight (approx.)	1600 kgs	1800 kgs	1800 kgs	1200 kgs	1350 kgs	1500 kgs

\*Specifications are subject to change without prior notice.

#### BMT 1540A / BMT 1540AV BMT 1560A / BMT 1560AV

- |  |  |
|--|--|
| <ul style="list-style-type: none"> <li>· Back plate</li> <li>· Steady rest</li> <li>· 4-way toolpost</li> <li>· 4-position carriage stop</li> <li>· Main motor</li> <li>· Thread dial indicator</li> <li>· Change gears</li> <li>· Foot brake &amp; emergency stop</li> <li>· Electromagnetic brake</li> <li>· Universal gear box</li> <li>· Dead center &amp; center sleeve</li> <li>· Leveling pads</li> <li>· Splash guard</li> <li>· Coolant system</li> <li>· Tools &amp; tool box</li> </ul> | <ul style="list-style-type: none"> <li>· 3-jaw &amp; 4-jaw chuck</li> <li>· Face plate</li> <li>· Follow rest</li> <li>· Taper turning attachment</li> <li>· Quick change toolpost</li> <li>· Live center</li> <li>· Drill chuck &amp; arbor</li> <li>· Chuck guard</li> <li>· Toolpost guard</li> <li>· Digital readout</li> <li>· Halogen lamp</li> <li>· CE &amp; CSA standard</li> </ul> |
|--|--|

#### BMT 1550BH / BMT 1550BHV

- |   |   |
|---|---|
| <ul style="list-style-type: none"> <li>· Back plate</li> <li>· Steady rest &amp; Follow rest</li> <li>· Dead center &amp; center sleeve</li> <li>· Leveling pads</li> <li>· Splash guard</li> <li>· Halogen lamp</li> <li>· Tools &amp; tool box</li> </ul> | <ul style="list-style-type: none"> <li>· 3-jaw &amp; 4-jaw chuck</li> <li>· Face plate</li> <li>· Driving plate</li> <li>· 5C collet &amp; collet attachment</li> <li>· Quick change toolpost</li> <li>· Taper turning attachment</li> <li>· Hydraulic copying attachment</li> <li>· Micrometer carriage stop</li> <li>· Drill chuck &amp; arbor</li> <li>· Chuck safety guard</li> <li>· Digital readout</li> <li>· CE standard</li> </ul> |
|---|---|

#### BMT 1530C / BMT 1540C / BMT 1550C

- |   |   |
|---|---|
| <ul style="list-style-type: none"> <li>· Back plate</li> <li>· 4-way toolpost</li> <li>· Motor &amp; electric control system</li> <li>· Thread dial indicator</li> <li>· Low voltage control system</li> <li>· Dead centers &amp; center sleeve</li> <li>· Leveling pads</li> <li>· Coolant system</li> <li>· Tools &amp; tool box</li> </ul> | <ul style="list-style-type: none"> <li>· 3-jaw &amp; 4-jaw chuck</li> <li>· Face plate</li> <li>· Steady rest &amp; Follow rest</li> <li>· Gap bed</li> <li>· 5C collet attachment</li> <li>· Taper turning attachment</li> <li>· Quick change toolpost</li> <li>· Chuck guard</li> <li>· Chip guard</li> <li>· Full length splash guard</li> <li>· Leadscrew cover</li> <li>· Micrometer carriage stop</li> <li>· Electromagnetic brake</li> <li>· Live center</li> <li>· LED lamp</li> <li>· CE &amp; CSA standard</li> </ul> |
|---|---|



## 6. SWING OVER BED 400 MM & 410 MM

▼ BMT 1525K / BMT 1550K



▼ BMT 1640A / BMT 1660A



▼ BMT 1640RMV / BMT 1660RMV



▼ BMT 1640TM / BMT 1660TM



### SPECIFICATION:

· Machines shown with optional accessories.

Description	BMT 1525K	BMT 1640A	BMT 1550K	BMT 1660A
Swing over bed	400 mm			
Swing over cross slide	246 mm	242 mm	246 mm	242 mm
Swing over gap	585 mm	552 mm	585 mm	552 mm
Center height	195 mm	200 mm	195 mm	200 mm
Distance between centers	650 mm	1000 mm	1250 mm	1500 mm
Bed width	318 mm	260 mm	318 mm	260 mm
Compound rest travel	100 mm	90 mm	100 mm	90 mm
Cross slide travel	250 mm	200 mm	250 mm	200 mm
Spindle nose	D1-6			
Spindle bore	54 mm	55 mm	54 mm	55 mm
Taper of spindle bore	MT 6			
Spindle speed	16 steps / 25~2000 rpm	12 steps / 50~2000 rpm	16 steps / 25~2000 rpm	12 steps / 50~2000 rpm
Taper of tailstock	MT 5	MT 4	MT 5	MT 4
Tailstock quill travel	145 mm	110 mm	145 mm	110 mm
Tailstock quill diameter	63 mm	52 mm	63 mm	52 mm
Main motor	10 HP	5 HP	10 HP	5 HP
Coolant pump motor	1/8 HP			
Machine size (L x W x H)	1864 x 1092 x 1232 mm	1900 x 780 x 1180 mm	2464 x 1092 x 1232 mm	2400 x 780 x 1180 mm
Machine packing size (L x W x H)	2080 x 1270 x 1630 mm	2083 x 864 x 1524 mm	2660 x 1270 x 1230 mm	2590 x 864 x 1524 mm
Net weight (approx.)	1350 kgs	860 kgs	1500 kgs	1020 kgs
Gross weight (approx.)	1550 kgs	960 kgs	1800 kgs	1140 kgs

\*Specifications are subject to change without prior notice.

#### BMT 1525K / BMT 1550K

- |  |   |
|--|---|
| <ul style="list-style-type: none"> <li>STANDARD ACCESSORIES</li> <li>· Back plate</li> <li>· Gap bed</li> <li>· Main spindle w/ gamet bearings</li> <li>· Thread dial indicator</li> <li>· Low voltage control system</li> <li>· Quick change toolpost</li> <li>· Dead center &amp; center sleeve</li> <li>· Coolant system &amp; chip guard</li> <li>· Chuck guard &amp; Splash guard</li> <li>· Leadscrew cover</li> <li>· Electromagnetic brake</li> <li>· Halogen lamp</li> <li>· CE standard</li> <li>· Tools &amp; tool box</li> </ul> | <ul style="list-style-type: none"> <li>OPTIONAL ACCESSORIES</li> <li>· 3-jaw &amp; 4-jaw chuck</li> <li>· Face plate</li> <li>· Steady rest &amp; Follow rest</li> <li>· Taper turning attachment</li> <li>· Micrometer carriage stop</li> <li>· Variable speed</li> <li>· Live center</li> <li>· LED lamp</li> <li>· CSA standard</li> </ul> |
|--|---|

#### BMT 1640A / BMT 1660A

- |   |  |
|---|--|
| <ul style="list-style-type: none"> <li>STANDARD ACCESSORIES</li> <li>· Back plate</li> <li>· Dead center &amp; center sleeve</li> <li>· Main motor</li> <li>· Change gear</li> <li>· Rear splash guard</li> <li>· Coolant system</li> <li>· Tools &amp; tool box</li> </ul> | <ul style="list-style-type: none"> <li>OPTIONAL ACCESSORIES</li> <li>· 3-jaw &amp; 4-jaw chuck</li> <li>· Face plate</li> <li>· Steady rest &amp; Follow rest</li> <li>· Micrometer carriage stop</li> <li>· 4-position carriage stop</li> <li>· Taper turning attachment</li> <li>· Quick change toolpost</li> <li>· Chuck guard</li> <li>· Digital readout</li> <li>· Work light</li> <li>· CE standard</li> </ul> |
|---|--|

### SPECIFICATION:

· Machines shown with optional accessories.

Description	BMT 1640RM BMT 1640RMV	BMT 1640TM	BMT 1660RM BMT 1660RMV	BMT 1660TM
Swing over bed	410 mm			
Swing over cross slide	262 mm			
Swing over gap	583 mm			
Center height	205 mm			
Distance between centers	1000 mm		1500 mm	
Bed width	260 mm			
Compound rest travel	130 mm			
Cross slide travel	220 mm			
Spindle nose	D1-6			
Spindle bore	52.5 mm			
Taper of spindle bore	MT 6			
Spindle speed	8 steps / 70~1800 rpm Vari. speeds / 20~2500 rpm	12 steps / 36~1800 rpm	8 steps / 70~1800 rpm Vari. speeds / 20~2500 rpm	12 steps / 36~1800 rpm
Taper of tailstock	MT 4			
Tailstock quill travel	152 mm			
Tailstock quill diameter	52 mm			
Main motor	5 HP			
Coolant pump motor	1/8 HP			
Machine size (L x W x H)	2080 x 900 x 1245 mm 2080 x 990 x 1370 mm	2080 x 900 x 1245 mm	2580 x 900 x 1245 mm 2580 x 990 x 1370 mm	2580 x 990 x 1245 mm
Machine packing size (L x W x H)	2270 x 1120 x 1745 mm		2785 x 1120 x 1745 mm	
Net weight (approx.)	1400 kgs	1500 kgs	1600 kgs	1600 kgs
Gross weight (approx.)	1550 kgs	1650 kgs	1750 kgs	1750 kgs

\*Specifications are subject to change without prior notice.

#### BMT 1640RM / BMT 1640RMV / BMT 1660RM BMT 1660RMV / BMT 1640TM / BMT 1660TM

- |   |  |
|---|--|
| <ul style="list-style-type: none"> <li>STANDARD ACCESSORIES</li> <li>· Back plate</li> <li>· Steady rest &amp; Follow rest</li> <li>· Dead center &amp; center sleeve</li> <li>· Leveling pads</li> <li>· Full length splash guard</li> <li>· Halogen lamp</li> <li>· Tools &amp; tool box</li> </ul> | <ul style="list-style-type: none"> <li>OPTIONAL ACCESSORIES</li> <li>· 3-jaw &amp; 4-jaw chuck</li> <li>· Face plate</li> <li>· Driving plate</li> <li>· 5C collet &amp; collet attachment</li> <li>· 16 steps speed motor</li> <li>· Quick change toolpost</li> <li>· Taper turning attachment</li> <li>· Hydraulic copying attachment</li> <li>· Micrometer carriage stop</li> <li>· Chuck safety guard</li> <li>· Digital readout</li> <li>· CE standard</li> </ul> |
|---|--|

## 7. SWING OVER BED 430 MM & 432 MM

▼ **BMT 1722G / BMT 1730G / BMT 1740G**  
**BMT 1760G / BMT 1790G**



▼ **BMT 1722GV / BMT 1730GV / BMT 1740GV**  
**BMT 1760GV / BMT 1790GV**



### SPECIFICATION:

· Machines shown with optional accessories.

Description	BMT 1722G BMT 1722GV	BMT 1730G BMT 1730GV	BMT 1740G BMT 1740GV	BMT 1760G BMT 1760GV	BMT 1790G BMT 1790GV
Swing over bed	430 mm				
Swing over cross slide	240 mm				
Swing over gap	650 mm				
Center height	215 mm				
Distance between centers	560 mm	760 mm	1000 mm	1500 mm	2200 mm
Bed width	300 mm				
Compound rest travel	125 mm				
Cross slide travel	250 mm				
Spindle nose	D1-6 / D1-8 (opt.)				
Spindle bore	58 mm				
Taper of spindle bore	MT 6 / MT 7 (opt.)				
Spindle speed	12 steps / 20~2000 rpm Vari. speeds / 20~2000rpm				
Taper of tailstock	MT 4				
Tailstock quill travel	150 mm				
Tailstock quill diameter	58 mm				
Main motor	5 HP / 7.5 HP (opt.)				
Coolant pump motor	1/8 HP				
Machine size (L x W x H)	1650 x 810 x 1190 mm	1890 x 810 x 1190 mm	2150 x 810 x 1190 mm	2650 x 810 x 1190 mm	3420 x 810 x 1190 mm
Machine packing size (L x W x H)	1820 x 950 x 1680 mm	2000 x 950 x 1680 mm	2280 x 950 x 1680 mm	2790 x 950 x 1680 mm	3550 x 950 x 1680 mm
Net weight (approx.)	1500 kgs	1680 kgs	1760 kgs	2050 kgs	2405 kgs
Gross weight (approx.)	1600 kgs	1780 kgs	1860 kgs	2200 kgs	2555 kgs

\*Specifications are subject to change without prior notice.

### BMT 1722G / BMT 1722GV / BMT 1730G / BMT 1730GV / BMT 1740G BMT 1740GV / BMT 1760G / BMT 1760GV / BMT 1790G / BMT 1790GV

#### STANDARD ACCESSORIES

- 3-jaw chuck
- Back plate
- Steady rest & Follow rest
- 4-way toolpost
- Auto-feed stopper ring
- Dead center & center sleeve
- Leveling pads
- Rear splash guard
- Coolant system
- Work light
- Tools & tool box

#### OPTIONAL ACCESSORIES

- 3-jaw & 4-jaw chuck
- Face plate
- Steady rest
- Enlarged spindle bore
- Enlarged motor
- Taper turning attachment
- Micrometer carriage stop
- 4-position carriage stop
- Live center
- Rear cutter rest
- Chuck guard
- American toolpost
- Change gears for D.P and module thread
- 5C collet attachment
- Driving plate
- Quick change toolpost
- Hydraulic copying attachment
- Chip guard
- ID/OD grinder
- Digital readout
- CE & CSA standard

## ▼ BMT 1740CL / BMT 1760CL



## ▼ BMT 1740LM / BMT 1760LM



### SPECIFICATION:

· Machines shown with optional accessories.

Description	BMT 1740CL BMT 1740CLV	BMT 1740LM BMT 1740LMV	BMT 1760CL BMT 1760CLV	BMT 1760LM BMT 1760LMV
Swing over bed	432 mm			
Swing over cross slide	277 mm			
Swing over gap	622 mm			
Center height	216 mm			
Distance between centers	1000 mm		1500 mm	
Bed width	305 mm			
Compound rest travel	160 mm			
Cross slide travel	235 mm			
Spindle nose	D1-6			
Spindle bore	52.5 mm	80 mm	52.5 mm	80 mm
Taper of spindle bore	MT 6	85 mm Taper 1/19.18	MT 6	85 mm Taper 1/19.18
Spindle speed	8 steps / 80~2000 rpm	12 steps / 36~1800 rpm	8 steps / 80~2000 rpm	12 steps / 36~1800 rpm
	Vari. speeds / 20~2500 rpm	Vari. speeds / 30~2200 rpm	Vari. speeds / 20~2500 rpm	Vari. speeds / 30~2200 rpm
Taper of tailstock	MT 4			
Tailstock quill travel	127 mm			
Tailstock quill diameter	59 mm			
Main motor	5 HP	7.5 HP	5 HP	7.5 HP
Coolant pump motor	1/8 HP			
Machine size (L x W x H)	2210 x 1000 x 1205 mm	2210 x 1125 x 1340 mm	2710 x 1000 x 1205 mm	2710 x 1125 x 1340 mm
	2210 x 1140 x 1455 mm	2210 x 1150 x 1535 mm	2710 x 1140 x 1455 mm	2710 x 1150 x 1535 mm
Machine packing size (L x W x H)	2400 x 1120 x 1745 mm	2400 x 1120 x 1756 mm	2900 x 1120 x 1745 mm	2900 x 1120 x 1756 mm
Net weight (approx.)	1600 kgs	1700 kgs	1850 kgs	1850 kgs
Gross weight (approx.)	1900 kgs	2000 kgs	2150 kgs	2150 kgs

\*Specifications are subject to change without prior notice.

### BMT 1740CL / BMT 1740CLV / BMT 1760CL / BMT 1760CLV BMT 1740LM / BMT 1740LMV / BMT 1760LM / BMT 1760LMV

#### STANDARD ACCESSORIES

- Back plate or Face plate
- Steady rest & Follow rest
- Dead center & center sleeve
- Leveling pads
- Full length splash guard
- Coolant system
- Halogen lamp
- Tools & tool box

#### OPTIONAL ACCESSORIES

- 3-jaw & 4-jaw chuck
- Face plate
- 5C collet & collet attachment
- 16 steps speed motor for BMT 1740CL, BMT 1740CLV, BMT 1760CL & BMT 1760CLV
- Micrometer carriage stop for BMT 1740CL, BMT 1740CLV, BMT 1760CL & BMT 1760CLV
- Quick change toolpost
- Taper turning attachment
- Hydraulic copying attachment
- Chuck safety guard
- Digital readout
- CE standard

## 8. SWING OVER BED 434 MM & 440 MM

▼ BMT 1740A / BMT 1760A



BMT 1740AV / BMT 1760AV ▼



▼ BMT 1740AS / BMT 1760AS / BMT 1780AS



· Machines shown with optional accessories.

BMT 1740ASV / BMT 1760ASV / BMT 1780ASV ▼



· Machines shown with optional accessories.

### SPECIFICATION:

Description	BMT 1740A BMT 1740AV	BMT 1760A BMT 1760AV	BMT 1740AS BMT 1740ASV	BMT 1760AS BMT 1760ASV	BMT 1780AS BMT 1780ASV
Swing over bed	434 mm		440 mm		
Swing over cross slide	277 mm		272 mm		
Swing over gap	630 mm		660 mm		
Center height	217 mm		220 mm		
Distance between centers	1000 mm	1500 mm	1000 mm	1500 mm	2000 mm
Bed width	300 mm		330 mm		
Compound rest travel	235 mm		260 mm		
Cross slide travel	235 mm		260 mm		
Spindle nose	D1-6		D1-8		
Spindle bore	58 mm		86 mm		
Taper of spindle bore	MT 6		MT 5		
Spindle speed	12 steps / 20~2000 rpm		12 steps / 20~1800 rpm		
	Vari. speeds / 10~2000 rpm		Vari. speeds / 10~2000 rpm		
Taper of tailstock	MT 4		MT 5		
Tailstock quill travel	125 mm		150 mm		
Tailstock quill diameter	58 mm		75 mm		
Main motor	7.5 HP		10 HP		
Coolant pump motor	1/8 HP				
Machine size (L x W x H)	2300 x 985 x 1265 mm	2810 x 985 x 1240 mm	2340 x 1085 x 1220 mm	2850 x 1085 x 1220 mm	3360 x 1085 x 1220 mm
	2300 x 985 x 1428 mm	2810 x 985 x 1428 mm	2340 x 1085 x 1325 mm	2850 x 1085 x 1325 mm	3360 x 1085 x 1325 mm
Machine packing size (L x W x H)	2340 x 1170 x 1680 mm	2900 x 1170 x 1680 mm	2340 x 1170 x 1650 mm	2950 x 1170 x 1660 mm	3450 x 1170 x 1650 mm
			2340 x 1270 x 1650 mm	2950 x 1270 x 1650 mm	3450 x 1270 x 1650 mm
Net weight (approx.)	1500 kgs	1700 kgs	1900 kgs	2000 kgs	2200 kgs
Gross weight (approx.)	1700 kgs	1900 kgs	2100 kgs	2200 kgs	2400 kgs

\*Specifications are subject to change without prior notice.

#### BMT 1740A / BMT 1740AV BMT 1760A / BMT 1760AV

##### STANDARD ACCESSORIES

- Back plate
- Steady rest
- 4-way toolpost
- 4-position carriage stop
- Main motor
- Thread dial indicator
- Change gears
- Foot brake & emergency stop
- Electromagnetic brake
- Universal gear box
- Dead center & center sleeve
- Leveling pads
- Splash guard
- Coolant system
- Tools & tool box

##### OPTIONAL ACCESSORIES

- 3-jaw & 4-jaw chuck
- Face plate
- Follow rest
- Taper turning attachment
- Quick change toolpost
- Live center
- Drill chuck & arbor
- Chuck guard
- Toolpost guard
- Digital readout
- Halogen lamp
- CE & CSA standard

#### BMT 1740AS / BMT 1740ASV / BMT 1760AS BMT 1760ASV / BMT 1780AS / BMT 1780ASV

##### STANDARD ACCESSORIES

- Back plate
- Steady rest
- 4-way toolpost
- 4-position carriage stop
- Main motor
- Thread dial indicator
- Changer gears
- Foot brake & emergency stop
- Dead center & center sleeve
- Leveling pads
- Splash guard
- Universal gear box
- Coolant system
- Tools & tool box

##### OPTIONAL ACCESSORIES

- 3-jaw & 4-jaw chuck
- Face plate
- Follow rest
- Taper turning attachment
- Quick change toolpost
- Live center
- Drill chuck & arbor
- Chuck guard
- Toolpost guard
- Digital readout
- Halogen lamp
- CE & CSA standard

## 9.SWING OVER BED 460 MM

▼ **BMT 1840M / BMT 1860M / BMT 1880M**



▼ **BMT 1840MA / BMT 1860MA / BMT 1880MA / BMT 18120MA**



· Machines shown with optional accessories.

### SPECIFICATION:

Description	BMT 1840M	BMT 1840MA	BMT 1860M	BMT 1860MA	BMT 1880M	BMT 1880MA	BMT 18120MA
Swing over bed	460 mm						
Swing over cross slide	285 mm	290 mm	285 mm	290 mm	285 mm	290 mm	
Swing over gap	640 mm (opt.)	710 mm	640 mm (opt.)	710 mm	640 mm (opt.)	710 mm	
Center height	230 mm	228 mm	230 mm	228 mm	230 mm	228 mm	
Distance between centers	1000 mm		1500 mm		2000 mm		3000 mm
Bed width	350 mm	345 mm	350 mm	345 mm	350 mm	345 mm	
Compound rest travel	120 mm	130 mm	120 mm	130 mm	120 mm	130 mm	
Cross slide travel	280 mm	265 mm	280 mm	265 mm	280 mm	265 mm	
Spindle nose	D1-6	D1-8	D1-6	D1-8	D1-6	D1-8	
Spindle bore	56 mm	80 mm	56 mm	80 mm	56 mm	80 mm	
Taper of spindle bore	-	MT 7	-	MT 7	-	MT 7	
Spindle speed	18 steps / 39~2800 rpm Vari. speeds / 33~3100rpm (opt.)	16 steps / 20~1600 rpm Vari. speeds / 16~2000 rpm (opt.)	18 steps / 39~2800 rpm Vari. speeds / 33~3100rpm (opt.)	16 steps / 20~1600 rpm Vari. speeds / 16~2000 rpm (opt.)	18 steps / 39~2800 rpm Vari. speeds / 33~3100rpm (opt.)	16 steps / 20~1600 rpm Vari. speeds / 16~2000 rpm (opt.)	
Taper of tailstock	MT 5						
Tailstock quill travel	170 mm	180 mm	170 mm	180 mm	170 mm	180 mm	
Tailstock quill diameter	75 mm						
Main motor	7.5 HP / 10 HP (opt.)	10 HP / 12.5 HP (opt.)	7.5 HP / 10 HP (opt.)	10 HP / 12.5 HP (opt.)	7.5 HP / 10 HP (opt.)	10 HP / 12.5 HP (opt.)	12.5 HP
Coolant pump motor	1/8 HP						
Machine size (L x W x H)	2385 x 1150 x 1862 mm	2237 x 1086 x 1325 mm	2885 x 1150 x 1826 mm	2745 x 1086 x 1325 mm	3385 x 1150 x 1826 mm	3254 x 1086 x 1325 mm	4254 x 1086 x 1325 mm
Machine packing size (L x W x H)	2290 x 1200 x 1700 mm	2460 x 1100 x 1573 mm	2790 x 1200 x 1700 mm	2947 x 1100 x 1573 mm	3290 x 1200 x 1700 mm	3455 x 1100 x 1573 mm	4470 x 1100 x 1573 mm
Net weight (approx.)	2000 kgs	1800 kgs	2250 kgs	2000 kgs	2500 kgs	2300 kgs	3300 kgs
Gross weight (approx.)	-	2050 kgs	-	2300 kgs	-	2650 kgs	3800 kgs

\*Specifications are subject to change without prior notice.

#### BMT 1840M / BMT 1860M / BMT 1880M

- |   |  |
|---|--|
| <ul style="list-style-type: none"> <li>■ STANDARD ACCESSORIES</li> <li>· 4-way toolpost</li> <li>· Main drive motor</li> <li>· Dead center &amp; center sleeve</li> <li>· Coolant system</li> <li>· Tools &amp; tool box</li> </ul> | <ul style="list-style-type: none"> <li>■ OPTIONAL ACCESSORIES</li> <li>· Z-axis rapid traverse</li> <li>· 3-jaw &amp; 4-jaw chuck</li> <li>· Face plate</li> <li>· Steady rest &amp; Follow rest</li> <li>· Gap bed</li> <li>· Electromagnetic brake</li> <li>· Inverter driven</li> <li>· Quick change toolpost</li> <li>· Taper turning attachment</li> <li>· Full length splash guard</li> <li>· Leadscrew guard</li> <li>· Micrometer carriage stopper</li> <li>· Turret type 5 position bed stopper</li> <li>· Live center</li> <li>· Digital readout</li> <li>· Halogen lamp</li> <li>· CE standard</li> </ul> |
|---|--|

#### BMT 1840MA / BMT 1860MA BMT 1880MA / BMT 18120MA

- |   |   |
|---|---|
| <ul style="list-style-type: none"> <li>■ STANDARD ACCESSORIES</li> <li>· Back plate</li> <li>· 4-way toolpost</li> <li>· Gap bed</li> <li>· Motor &amp; electric control system</li> <li>· Thread dial indicator</li> <li>· Low voltage control system</li> <li>· Dead center &amp; center sleeve</li> <li>· Leveling pads</li> <li>· Coolant system</li> <li>· Tools &amp; tool box</li> </ul> | <ul style="list-style-type: none"> <li>■ OPTIONAL ACCESSORIES</li> <li>· Z-axis rapid traverse</li> <li>· 3-jaw &amp; 4-jaw chuck</li> <li>· Face plate</li> <li>· Steady rest &amp; Follow rest</li> <li>· Taper turning attachment</li> <li>· Quick change toolpost</li> <li>· Chuck guard</li> <li>· Chip guard</li> <li>· Full length splash guard</li> <li>· Leadscrew cover</li> <li>· Electromagnetic brake</li> <li>· Micrometer carriage stop</li> <li>· Live center</li> <li>· LED lamp</li> <li>· CE &amp; CSA standard</li> </ul> |
|---|---|

## 10.SWING OVER BED 462 MM

▼ **BMT 1840FC / BMT 1860FC / BMT 1880FC**  
**BMT 1840FCV / BMT 1860FCV / BMT 1880FCV**



▼ **BMT 1840AH / BMT 1860AH / BMT 1880AH**

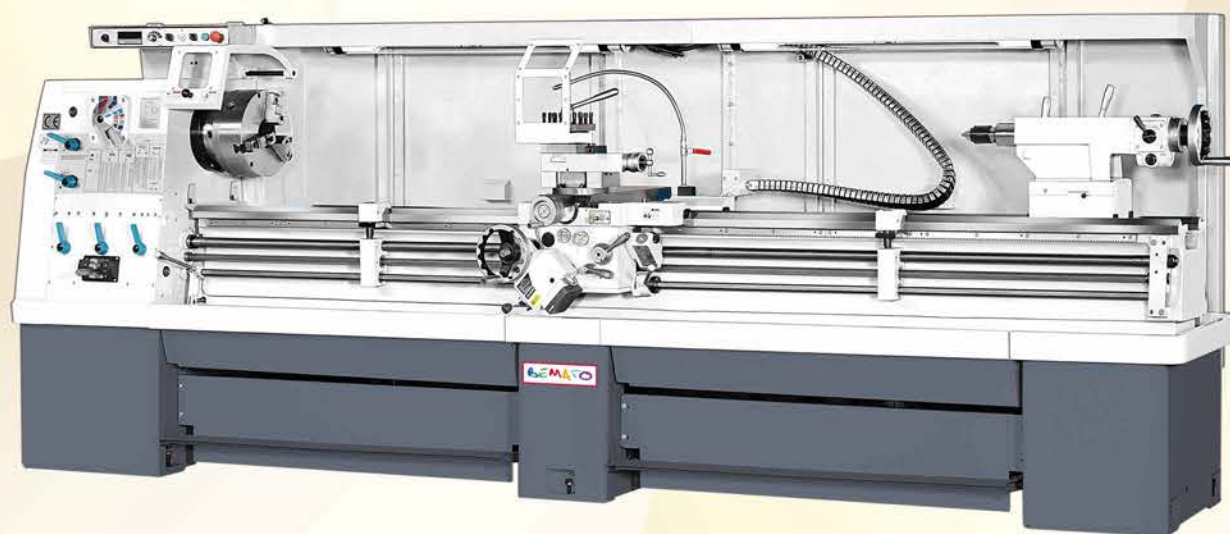

· Machines shown with optional accessories.

▼ **BMT 1840AHV / BMT 1860AHV / BMT 1880AHV**



· Machines shown with optional accessories.

### SPECIFICATION:

Description	BMT 1840AH BMT 1840AHV	BMT 1840FC BMT 1840FCV	BMT 1860AH BMT 1860AHV	BMT 1860FC BMT 1860FCV	BMT 1880AH BMT 1880AHV	BMT 1880FC BMT 1880FCV
Swing over bed	462 mm					
Swing over cross slide	298 mm	305 mm	298 mm	305 mm	298 mm	305 mm
Swing over gap	710 mm	650 mm	710 mm	650 mm	710 mm	650 mm
Center height	231 mm					
Distance between centers	1000 mm		1500 mm		2000 mm	2200 mm
Bed width	345 mm	320 mm	345 mm	320 mm	345 mm	320 mm
Compound rest travel	137 mm	150 mm	137 mm	150 mm	137 mm	150 mm
Cross slide travel	272 mm	300 mm	272 mm	300 mm	272 mm	300 mm
Spindle nose	D1-8	D1-8 / A1-8 (opt.)	D1-8	D1-8 / A1-8 (opt.)	D1-8	D1-8 / A1-8 (opt.)
Spindle bore	80 mm					
Taper of spindle bore	MT 7	85 mm Taper 1/19.18	MT 7	85 mm Taper 1/19.18	MT 7	85 mm Taper 1/19.18
Spindle speed	16 steps / 20~1600 rpm	12 steps / 26~1500 rpm	16 steps / 20~1600 rpm	12 steps / 26~1500 rpm	16 steps / 20~1600 rpm	12 steps / 26~1500 rpm
	Var. speeds / 18~1800 rpm	Var. speeds / 25~1800 rpm	Var. speeds / 18~1800 rpm	Var. speeds / 25~1800 rpm	Var. speeds / 18~1800 rpm	Var. speeds / 25~1800 rpm
Taper of tailstock	MT 5	MT 4	MT 5	MT 4	MT 5	MT 4
Tailstock quill travel	165 mm	127 mm	165 mm	127 mm	165 mm	153 mm
Tailstock quill diameter	76 mm	59 mm	76 mm	59 mm	76 mm	68 mm
Main motor	10 HP	10 HP / 12.5 HP (opt.)	10 HP	10 HP / 12.5 HP (opt.)	10 HP	10 HP / 12.5 HP (opt.)
Coolant pump motor	1/8 HP					
Machine size (L x W x H)	2385 x 1075 x 1455 mm	2377 x 1450 x 1336mm	2885 x 1075 x 1455 mm	2877 x 1450 x 1336mm	3385 x 1075 x 1455 mm	3677 x 1450 x 1336mm
	2385 x 1145 x 1575 mm		2885 x 1145 x 1575 mm		3385 x 1145 x 1575 mm	
Machine packing size (L x W x H)	2535 x 1120 x 1745 mm	2400 x 1155 x 1900mm	3035 x 1120 x 1745 mm	2900 x 1155 x 1900mm	3535 x 1120 x 1745 mm	3700 x 1155 x 1900mm
Net weight (approx.)	2000 kgs	1800 kgs	2350 kgs	1950 kgs	2700 kgs	2350 kgs
Gross weight (approx.)	2350 kgs	2000 kgs	2700 kgs	2200 kgs	3100 kgs	2650 kgs

\*Specifications are subject to change without prior notice.

#### BMT 1840AH / BMT 1840AHV / BMT 1860AH BMT 1860AHV / BMT 1880AH / BMT 1880AHV

- |   |   |
|---|---|
| <ul style="list-style-type: none"> <li>STANDARD ACCESSORIES</li> <li>· Back plate</li> <li>· Steady rest &amp; Follow rest</li> <li>· Dead center &amp; center sleeve</li> <li>· Leveling pads</li> <li>· Full length splash guard</li> <li>· Halogen lamp</li> <li>· Tools &amp; tool box</li> </ul> | <ul style="list-style-type: none"> <li>OPTIONAL ACCESSORIES</li> <li>· 3-jaw &amp; 4-jaw chuck</li> <li>· Face plate</li> <li>· 5C collet &amp; collet attachment</li> <li>· Rapid traverse motor</li> <li>· Quick change toolpost</li> <li>· Taper turning attachment</li> <li>· Hydraulic copying attachment</li> <li>· Micrometer carriage stop</li> <li>· Chuck safety guard</li> <li>· Digital readout</li> <li>· CE standard</li> </ul> |
|---|---|

#### BMT 1840FC / BMT 1840FCV / BMT 1860FC BMT 1860FCV / BMT 1880FC / BMT 1880FCV

- |  |  |
|--|--|
| <ul style="list-style-type: none"> <li>STANDARD ACCESSORIES</li> <li>· Back plate</li> <li>· Dead center &amp; center sleeve</li> <li>· Leveling pads</li> <li>· Tools &amp; tool box</li> </ul> | <ul style="list-style-type: none"> <li>OPTIONAL ACCESSORIES</li> <li>· 3-jaw &amp; 4-jaw chuck</li> <li>· Face plate</li> <li>· A1-8 spindle taper</li> <li>· Enlarge motor 12.5HP</li> <li>· Quick change toolpost</li> <li>· Taper turning attachment</li> <li>· Hydraulic copying attachment</li> <li>· Chuck safety guard</li> <li>· Digital readout</li> <li>· CE standard</li> </ul> |
|--|--|

## 11. SWING OVER BED 470 MM

▼ BMT 1922G / BMT 1930G / BMT 1940G / BMT 1960G / BMT 1990G



▼ BMT 1922GV / BMT 1930GV / BMT 1940GV / BMT 1960GV / BMT 1990GV



· Machines shown with optional accessories.



◀ Plastic gear on the rear side of headstock

### SPECIFICATION:

Description	BMT 1922G BMT 1922GV	BMT 1930G BMT 1930GV	BMT 1940G BMT 1940GV	BMT 1960G BMT 1960GV	BMT 1990G BMT 1990GV
Swing over bed	470 mm				
Swing over cross slide	280 mm				
Swing over gap	690 mm				
Center height	235 mm				
Distance between centers	560 mm	760 mm	1000 mm	1500 mm	2200 mm
Bed width	300 mm				
Compound rest travel	125 mm				
Cross slide travel	250 mm				
Spindle nose	D1-6 / D1-8 (opt.)				
Spindle bore	58 mm / 80 mm (opt.)				
Taper of spindle bore	MT 6 / MT 7 (opt.)				
Spindle speed	12 steps / 20~2000 rpm Vari. speeds / 20~2000 rpm				
Taper of tailstock	MT 4				
Tailstock quill travel	150 mm				
Tailstock quill diameter	68 mm				
Main motor	7.5 HP / 10 HP (opt.)				
Coolant pump motor	1/8 HP				
Machine size (L x W x H)	1650 x 810 x 1220 mm	1890 x 810 x 1220 mm	2150 x 810 x 1220 mm	2650 x 810 x 1220 mm	3420 x 810 x 1220 mm
Machine packing size (L x W x H)	1820 x 950 x 1680 mm	2000 x 950 x 1680 mm	2280 x 950 x 1680 mm	2790 x 950 x 1680 mm	3550 x 950 x 1680 mm
Net weight (approx.)	1540 kgs	1720 kgs	1800 kgs	2075 kgs	2465 kgs
Gross weight (approx.)	1640 kgs	1820 kgs	1900 kgs	2225 kgs	2615 kgs

\*Specifications are subject to change without prior notice.

### BMT 1922G / BMT 1922GV / BMT 1930G / BMT 1930GV / BMT 1940G BMT 1940GV / BMT 1960G / BMT 1960GV / BMT 1990G / BMT 1990GV

#### ■ STANDARD ACCESSORIES

- 3-jaw chuck
- Back plate
- Steady rest & Follow rest
- 4-way toolpost
- Auto-feed stopper ring
- Dead center & center sleeve
- Leveling pads
- Rear splash guard
- Coolant system
- Work light
- Tools & tool box

#### ■ OPTIONAL ACCESSORIES

- 3-jaw & 4-jaw chuck
- Face plate
- Steady rest
- Enlarged spindle bore
- Enlarged motor
- Taper turning attachment
- Micrometer carriage stop
- 4-position carriage stop
- Live center
- Rear cutter rest
- Chuck guard
- American toolpost
- Change gears for D.P and module thread
- 5C collet attachment
- Driving plate
- Quick change toolpost
- Hydraulic copying attachment
- Chip guard
- ID/OD grinder
- Digital readout
- CE & CSA standard

## 12.SWING OVER BED 508 MM & 510 MM

### ▼ BMT 2040LM / BMT 2060LM



### ▼ BMT 2040AS / BMT 2060AS / BMT 2080AS



· Machines shown with optional accessories.

### SPECIFICATION:

Description	BMT 2040LM BMT 2040LMV	BMT 2060LM BMT 2060LMV	BMT 2040AS BMT 2040ASV	BMT 2040MA
Swing over bed	508 mm		510 mm	
Swing over cross slide	353 mm		342 mm	340 mm
Swing over gap	698 mm		730 mm	760 mm
Center height	254 mm		255 mm	254 mm
Distance between centers	1000 mm	1500 mm	1000 mm	
Bed width	305 mm		330 mm	345 mm
Compound rest travel	160 mm		260 mm	130 mm
Cross slide travel	272 mm		260 mm	265 mm
Spindle nose	D1-6		D1-8	
Spindle bore	80 mm		86 mm	80 mm
Taper of spindle bore	85 mm Taper 1/19.18		MT 5	MT 7
Spindle speed	12 steps / 36~1800 rpm		12 steps / 20~1800 rpm	16 steps / 20~1600 rpm Vari. speeds / 16~2000 rpm (opt.)
	Vari. speeds / 30~2200 rpm		Vari. speeds / 10~2000 rpm	
Taper of tailstock	MT 4		MT 5	
Tailstock quill travel	127 mm		150 mm	180 mm
Tailstock quill diameter	59 mm		75 mm	
Main motor	7.5 HP		10 HP	
Coolant pump motor	1/8 HP			
Machine size (L x W x H)	2210 x 1125 x 1340 mm	2710 x 1125 x 1340 mm	2340 x 1085 x 1257 mm	2237 x 1086 x 1349 mm
	2210 x 1150 x 1535 mm	2710 x 1150 x 1535 mm	2340 x 1085 x 1362 mm	
Machine packing size (L x W x H)	2400 x 1120 x 1756 mm	2900 x 1120 x 1756 mm	2340 x 1170 x 1700 mm	2460 x 1100 x 1778 mm
			2340 x 1270 x 1700 mm	
Net weight (approx.)	1750 kgs	1900 kgs	2000 kgs	2000 kgs
Gross weight (approx.)	2050 kgs	2200 kgs	2200 kgs	2250 kgs

\*Specifications are subject to change without prior notice.

#### BMT 2040LM / BMT 2040LMV BMT 2060LM / BMT 2060LMV

- |   |   |
|---|---|
| <ul style="list-style-type: none"> <li>STANDARD ACCESSORIES</li> <li>· Back plate or Face plate</li> <li>· Steady rest &amp; Follow rest</li> <li>· Dead center &amp; center sleeve</li> <li>· Leveling pads</li> <li>· Full length splash guard</li> <li>· Coolant system</li> <li>· Halogen lamp</li> <li>· Tools &amp; tool box</li> </ul> | <ul style="list-style-type: none"> <li>OPTIONAL ACCESSORIES</li> <li>· 3-jaw &amp; 4-jaw chuck</li> <li>· Face plate</li> <li>· 5C collet &amp; collet attachment</li> <li>· Quick change toolpost</li> <li>· Taper turning attachment</li> <li>· Hydraulic copying attachment</li> <li>· Chuck safety guard</li> <li>· Digital readout</li> <li>· CE standard</li> </ul> |
|---|---|

#### BMT 2040AS / BMT 2040ASV / BMT 2060AS BMT 2060ASV / BMT 2080AS / BMT 2080ASV

- |  |  |
|--|--|
| <ul style="list-style-type: none"> <li>STANDARD ACCESSORIES</li> <li>· Back plate</li> <li>· Steady rest</li> <li>· 4-way toolpost</li> <li>· 4-position carriage stop</li> <li>· Main motor</li> <li>· Thread dial indicator</li> <li>· Changer gears</li> <li>· Foot brake &amp; emergency stop</li> <li>· Dead center &amp; center sleeve</li> <li>· Leveling pads</li> <li>· Splash guard</li> <li>· Universal gear box</li> <li>· Coolant system</li> <li>· Tools &amp; tool box</li> </ul> | <ul style="list-style-type: none"> <li>OPTIONAL ACCESSORIES</li> <li>· 3-jaw &amp; 4-jaw chuck</li> <li>· Face plate</li> <li>· Follow rest</li> <li>· Taper turning attachment</li> <li>· Quick change toolpost</li> <li>· Live center</li> <li>· Drill chuck &amp; arbor</li> <li>· Chuck guard</li> <li>· Toolpost guard</li> <li>· Digital readout</li> <li>· Halogen lamp</li> <li>· CE &amp; CSA standard</li> </ul> |
|--|--|



· Machines shown with optional accessories.

### ▼ BMT 2040MA / BMT 2060MA / BMT 2080MA / BMT 20120MA

### SPECIFICATION:

Description	BMT 2060AS BMT 2060ASV	BMT 2060MA	BMT 2080AS BMT 2080ASV	BMT 2080MA	BMT 20120MA
Swing over bed			510 mm		
Swing over cross slide	342 mm	340 mm	342 mm	340 mm	
Swing over gap	730 mm	760 mm	730 mm	760 mm	
Center height	255 mm	254 mm	255 mm	254 mm	
Distance between centers	1500 mm		2000 mm		3000 mm
Bed width	330 mm	345 mm	330 mm	345 mm	
Compound rest travel	260 mm	130 mm	260 mm	130 mm	
Cross slide travel	260 mm	265 mm	260 mm	265 mm	
Spindle nose	D1-8				
Spindle bore	86 mm	80 mm	86 mm	80 mm	
Taper of spindle bore	MT 5	MT 7	MT 5	MT 7	
Spindle speed	12 steps / 20~1800 rpm	16 steps / 20~1600 rpm Vari. speeds 16~2000 rpm (opt.)	12 steps / 20~1800 rpm	16 steps / 20~1600 rpm Vari. speeds / 16~2000 rpm (opt.)	
	Vari. speeds / 10~2000 rpm				
Taper of tailstock	MT 5				
Tailstock quill travel	150 mm	180 mm	150 mm	180 mm	
Tailstock quill diameter	75 mm				
Main motor	10 HP				12.5 HP
Coolant pump motor	1/8 HP				
Machine size (L x W x H)	2850 x 1085 x 1257 mm	2745 x 1086 x 1349 mm	3360 x 1085 x 1257 mm	3254 x 1086 x 1349 mm	4254 x 1086 x 1349 mm
	2850 x 1085 x 1362 mm		3360 x 1085 x 1362 mm		
Machine packing size (L x W x H)	2950 x 1170 x 1700 mm	2947 x 1100 x 1778mm	3450 x 1170 x 1700 mm	3455 x 1100 x 1778 mm	4470 x 1100 x 1778 mm
	2950 x 1270 x 1700 mm		3450 x 1270 x 1700 mm		
Net weight (approx.)	2100 kgs	2200 kgs	2300 kgs	2500 kgs	3500 kgs
Gross weight (approx.)	2300 kgs	2500 kgs	2500 kgs	2850 kgs	4000 kgs

\*Specifications are subject to change without prior notice.

#### BMT 2040MA / BMT 2060MA / BMT 2080MA / BMT 20120MA

- |   |   |  |
|---|---|--|
| <ul style="list-style-type: none"> <li>STANDARD ACCESSORIES</li> <li>· Back plate</li> <li>· 4-way toolpost</li> <li>· Gap bed</li> <li>· Motor &amp; electric control system</li> <li>· Thread dial indicator</li> <li>· Low voltage control system</li> <li>· Dead center &amp; center sleeve</li> <li>· Leveling pads</li> <li>· Coolant system</li> <li>· Tools &amp; tool box</li> </ul> | <ul style="list-style-type: none"> <li>OPTIONAL ACCESSORIES</li> <li>· Z-axis rapid traverse</li> <li>· 3-jaw &amp; 4-jaw chuck</li> <li>· Face plate</li> <li>· Steady rest &amp; Follow rest</li> <li>· Enlarged motor</li> <li>· Taper turning attachment</li> <li>· Quick change toolpost</li> <li>· Chuck guard</li> </ul> | <ul style="list-style-type: none"> <li>· Chip guard</li> <li>· Full length splash guard</li> <li>· Leadscrew cover</li> <li>· Electromagnetic brake</li> <li>· Micrometer carriage stop</li> <li>· Live center</li> <li>· LED lamp</li> <li>· CE &amp; CSA standard</li> </ul> |
|---|---|--|

## 13. SWING OVER BED 520 MM

▼ BMT 2122G / BMT 2130G / BMT 2140G / BMT 2160G / BMT 2190G



▼ BMT 2122GV / BMT 2130GV / BMT 2140GV / BMT 2160GV / BMT 2190GV



· Machines shown with optional accessories.



◀ Clutched hand wheel, prevent rotation and collision of the handle during rapid traverse

### SPECIFICATION:

Description	BMT 2122G BMT 2122GV	BMT 2130G BMT 2130GV	BMT 2140G BMT 2140GV	BMT 2160G BMT 2160GV	BMT 2190G BMT 2190GV
Swing over bed	520 mm				
Swing over cross slide	330 mm				
Swing over gap	740 mm				
Center height	260 mm				
Distance between centers	560 mm	760 mm	1000 mm	1500 mm	2200 mm
Bed width	300 mm				
Compound rest travel	125 mm				
Cross slide travel	275 mm				
Spindle nose	D1-6 / D1-8 (opt.)				
Spindle bore	80 mm				
Taper of spindle bore	MT 6 / MT 7 (opt.)				
Spindle speed	12 steps / 20~2000 rpm Vari. speeds / 20~2000 rpm				
Taper of tailstock	MT 4				
Tailstock quill travel	150 mm				
Tailstock quill diameter	68 mm				
Main motor	7.5 HP / 10 HP (opt.)				
Coolant pump motor	1/8 HP				
Machine size (L x W x H)	1650 x 810 x 1250 mm	1890 x 810 x 1250 mm	2150 x 810 x 1250 mm	2650 x 810 x 1250 mm	3420 x 810 x 1220 mm
Machine packing size (L x W x H)	1820 x 950 x 1680 mm	2000 x 950 x 1680 mm	2280 x 950 x 1680 mm	2790 x 950 x 1680 mm	3550 x 950 x 1680 mm
Net weight (approx.)	1580 kgs	1760 kgs	1810 kgs	2135 kgs	2525 kgs
Gross weight (approx.)	1680 kgs	1860 kgs	1910 kgs	2285 kgs	2675 kgs

\*Specifications are subject to change without prior notice.

### BMT 2122G / BMT 2122GV / BMT 2130G / BMT 2130GV / BMT 2140G BMT 2140GV / BMT 2160G / BMT 2160GV / BMT 2190G / BMT 2190GV

#### STANDARD ACCESSORIES

- 3-jaw chuck
- Back plate
- Steady rest & Follow rest
- 4-way toolpost
- Auto-feed stopper ring
- Dead center & center sleeve
- Leveling pads
- Rear splash guard
- Coolant system
- Work light
- Tools & tool box

#### OPTIONAL ACCESSORIES

- 3-jaw & 4-jaw chuck
- Face plate
- Enlarged spindle bore
- Enlarged motor
- Taper turning attachment
- Micrometer carriage stop
- 4-position carriage stop
- Live center
- Rear cutter rest
- Chuck guard
- American toolpost
- Change gears for D.P and module thread
- 5C collet attachment
- Driving plate
- Quick change toolpost
- Hydraulic copying attachment
- Chip guard
- ID/OD grinder
- Digital readout
- CE & CSA standard



## 14. SWING OVER BED 540 MM & 542 MM

▼ **BMT 2140M / BMT 2160M / BMT 2180M / BMT 21120M**



· Machines shown with optional accessories.

### SPECIFICATION:

Description	BMT 2140M	BMT 2160M	BMT 2180M	BMT 21120M
Swing over bed	540 mm			
Swing over cross slide	360 mm			
Swing over gap	720 mm (opt.)			
Center height	270 mm			
Distance between centers	1000 mm	1500 mm	2000 mm	3000 mm
Bed width	350 mm			
Compound rest travel	150 mm			
Cross slide travel	330 mm			
Spindle nose	D1-8 / A2-11 (opt.)			
Spindle bore	85 mm			
Taper of spindle bore	-			
Spindle speed	18 steps / 25~1545 rpm Vari. speeds / 27~2250 rpm (opt.)			
Taper of tailstock	MT 5			
Tailstock quill travel	170 mm			
Tailstock quill diameter	75 mm			
Main motor	10 HP / 15 HP (opt.)			
Coolant pump motor	1/8 HP			
Machine size (L x W x H)	2390 x 1150 x 1900 mm	2890 x 1150 x 1900 mm	3390 x 1150 x 1900 mm	4390 x 1150 x 1900 mm
Machine packing size (L x W x H)	2290 x 1200 x 1700 mm	2790 x 1200 x 1700 mm	3290 x 1200 x 1700 mm	4290 x 1200 x 1700 mm
Net weight (approx.)	2200 kgs	2450 kgs	2600 kgs	2700 kgs
Gross weight (approx.)	-			

\*Specifications are subject to change without prior notice.

### BMT 2140M / BMT 2160M / BMT 2180M / BMT 21120M

STANDARD ACCESSORIES	OPTIONAL ACCESSORIES
<ul style="list-style-type: none"> <li>4-way toolpost</li> <li>Dead center &amp; center sleeve</li> <li>Coolant system</li> <li>Tools &amp; tool box</li> </ul>	<ul style="list-style-type: none"> <li>Z-axis rapid traverse</li> <li>3-jaw &amp; 4-jaw chuck</li> <li>Face plate</li> <li>Steady rest &amp; Follow rest</li> <li>Gap bed</li> <li>Enlarged spindle bore</li> <li>Electromagnetic brake</li> <li>Inverter driven</li> <li>Quick change toolpost</li> <li>Taper turning attachment</li> <li>Full length splash guard</li> <li>Leadscrew guard</li> <li>Micrometer carriage stopper</li> <li>Turret type 5 position bed stopper</li> <li>Live center</li> <li>Digital readout</li> <li>Halogen lamp</li> <li>CE standard</li> </ul>

▼ **BMT 2140FC / BMT 2160FC  
BMT 2180FC**



▼ **BMT 2140AH / BMT 2160AH  
BMT 2180AH / BMT 21120AH**



· Machines shown with optional accessories.

### SPECIFICATION:

Description	BMT 2140FC BMT 2140FCV	BMT 2140AH BMT 2140AHV	BMT 2160FC BMT 2160FCV	BMT 2160AH BMT 2160AHV	BMT 2180AH BMT 2180AHV	BMT 2180FC BMT 2180FCV	BMT 21120AH BMT 21120AHV
Swing over bed	542 mm						
Swing over cross slide	387 mm	380 mm	387 mm	380 mm	387 mm	380 mm	380 mm
Swing over gap	730 mm	790 mm	730 mm	790 mm	730 mm	790 mm	790 mm
Center height	271 mm						
Distance between centers	1000 mm		1500 mm		2000 mm	2200 mm	3000 mm
Bed width	320 mm	345 mm	320 mm	345 mm	320 mm	345 mm	345 mm
Compound rest travel	150 mm	137 mm	150 mm	137 mm	150 mm	137 mm	137 mm
Cross slide travel	300 mm	272 mm	300 mm	272 mm	300 mm	272 mm	272 mm
Spindle nose	D1-8						
Spindle bore	80 mm						
Taper of spindle bore	85 mm Taper 1/19,18	MT 7	85 mm Taper 1/19,18	MT 7	85 mm Taper 1/19,18	MT 7	MT 7
Spindle speed	12 steps / 26~1500 rpm Vari. speeds / 25~1800 rpm	16 steps / 20~1600 rpm Vari. speeds / 18~1800 rpm	12 steps / 26~1500 rpm Vari. speeds / 25~1800 rpm	16 steps / 20~1600 rpm Vari. speeds / 18~1800 rpm	12 steps / 26~1500 rpm Vari. speeds / 25~1800 rpm	16 steps / 20~1600 rpm Vari. speeds / 18~1800 rpm	16 steps / 20~1600 rpm Vari. speeds / 18~1800 rpm
Taper of tailstock	MT 4	MT 5	MT 4	MT 5	MT 4	MT 5	MT 5
Tailstock quill travel	127 mm	165 mm	127 mm	165 mm	153 mm	165 mm	165 mm
Tailstock quill diameter	59 mm	76 mm	59 mm	76 mm	68 mm	76 mm	76 mm
Main motor	10 HP / 12.5 HP (opt.)	12.5 HP	10 HP / 12.5 HP (opt.)	12.5 HP	10 HP / 12.5 HP (opt.)	12.5 HP	12.5 HP
Coolant pump motor	1/8 HP						
Machine size (L x W x H)	2377 x 1450 x 1336 mm	2385 x 1075 x 1455 mm 2385 x 1145 x 1575 mm	2877 x 1450 x 1336 mm	2885 x 1075 x 1455 mm 2885 x 1145 x 1575 mm	3385 x 1075 x 1455 mm 3385 x 1145 x 1575 mm	3677 x 1450 x 1336 mm	4410 x 1075 x 1455 mm 4410 x 1145 x 1575 mm
Machine packing size (L x W x H)	2400 x 1155 x 1900 mm	2535 x 1120 x 1745 mm	2900 x 1155 x 1900 mm	3035 x 1120 x 1745 mm	3535 x 1120 x 1745 mm	3700 x 1155 x 1900 mm	4624 x 1120 x 1745 mm
Net weight (approx.)	1850 kgs	2300 kgs	2000 kgs	2650 kgs	3000 kgs	2400 kgs	3700 kgs
Gross weight (approx.)	2050 kgs	2650 kgs	2900 kgs	3000 kgs	3400 kgs	2700 kgs	4200 kgs

\*Specifications are subject to change without prior notice.

### BMT 2140FC / BMT 2140FCV / BMT 2160FC BMT 2160FCV / BMT 2180FC / BMT 2180FCV

STANDARD ACCESSORIES	OPTIONAL ACCESSORIES
<ul style="list-style-type: none"> <li>Back plate</li> <li>Dead center &amp; center sleeve</li> <li>Leveling pads</li> <li>Tools &amp; tool box</li> </ul>	<ul style="list-style-type: none"> <li>3-jaw &amp; 4-jaw chuck</li> <li>Face plate</li> <li>A1-8 spindle taper</li> <li>Enlarged motor 12.5HP</li> <li>Quick change toolpost</li> <li>Taper turning attachment</li> <li>Chuck safety guard</li> <li>Digital readout</li> <li>CE standard</li> </ul>

### BMT 2140AH / BMT 2140AHV / BMT 2160AH BMT 2160AHV / BMT 2180AH / BMT 2180AHV

STANDARD ACCESSORIES	OPTIONAL ACCESSORIES
<ul style="list-style-type: none"> <li>Back plate</li> <li>Steady rest &amp; Follow rest</li> <li>Dead center &amp; center sleeve</li> <li>Leveling pads</li> <li>Full length splash guard</li> <li>Halogen lamp</li> <li>Tools &amp; tool box</li> </ul>	<ul style="list-style-type: none"> <li>3-jaw &amp; 4-jaw chuck</li> <li>Face plate</li> <li>5C collet &amp; collet attachment</li> <li>Rapid traverse motor</li> <li>Quick change toolpost</li> <li>Taper turning attachment</li> <li>Hydraulic copying attachment</li> <li>Micrometer carriage stop</li> <li>Chuck safety guard</li> <li>Digital readout</li> <li>CE standard</li> </ul>

## 15.SWING OVER BED 560 MM

▼ BMT 2240M / BMT 2260M / BMT 2290M



▼ BMT 2240L / BMT 2260L / BMT 2280L  
BMT 22100L / BMT 22120L / BMT 22160L



· Machines shown with optional accessories.

### SPECIFICATION:

Description	BMT 2240M	BMT 2240L	BMT 2240MA	BMT 2260M	BMT 2260L	BMT 2260MA
Swing over bed	560 mm					
Swing over cross slide	340 mm		390 mm	340 mm		390 mm
Swing over gap	788 mm		810 mm	788 mm		810 mm
Center height	280 mm					
Distance between centers	1000 mm			1500 mm		
Bed width	350 mm	400 mm	345 mm	350 mm	400 mm	345 mm
Compound rest travel	200 mm		130 mm	200 mm		130 mm
Cross slide travel	300 mm	375 mm	265 mm	300 mm	375 mm	265 mm
Spindle nose	D1-8	D1-8 / D1-11 (opt.)	D1-8	D1-8	D1-8 / D1-11 (opt.)	D1-8
Spindle bore	85 mm / 105 mm (opt.)		80 mm	85 mm / 105 mm (opt.)		80 mm
Taper of spindle bore	MT 7					
Spindle speed	12 steps / 15~1500 rpm		16 steps / 20~1600 rpm Vari. speeds / 16~2000 rpm (opt.)	12 steps / 15~1500 rpm		16 steps / 20~1600 rpm Vari. speeds / 16~2000 rpm (opt.)
Taper of tailstock	MT 5					
Tailstock quill travel	165 mm		180 mm	165 mm		180 mm
Tailstock quill diameter	75 mm	85 mm	75 mm	85 mm	75 mm	75 mm
Main motor	7.5 HP / 10 HP (opt.)	10 HP / 15 HP (opt.)	10 HP / 12.5 HP (opt.)	7.5 HP / 10 HP (opt.)	10 HP / 15 HP (opt.)	10 HP / 12.5 HP (opt.)
Coolant pump motor	1/8 HP					
Machine size (L x W x H)	2290 x 990 x 1250 mm	2380 x 1030 x 1260 mm	2237 x 1086 x 1375 mm	2780 x 990 x 1250 mm	2900 x 1030 x 1260 mm	2745 x 1086 x 1375 mm
Machine packing size (L x W x H)	2380 x 1150 x 1700 mm	2700 x 1150 x 1930 mm	2460 x 1100 x 1830 mm	2900 x 1150 x 1700 mm	3150 x 1150 x 1930 mm	2947 x 1100 x 1830 mm
Net weight (approx.)	2200 kgs			2400 kgs	2550 kgs	2400 kgs
Gross weight (approx.)	2350 kgs	2300 kgs	2500 kgs	2550 kgs	2650 kgs	2700 kgs

\*Specifications are subject to change without prior notice.

### BMT 2240M / BMT 2260M / BMT 2290M

STANDARD ACCESSORIES	OPTIONAL ACCESSORIES
<ul style="list-style-type: none"> <li>3-jaw chuck</li> <li>Back plate</li> <li>Steady rest &amp; Follow rest</li> <li>4-way toolpost</li> <li>Screw wrench for cutter setting</li> <li>Auto-feed stopper ring</li> <li>Dead center &amp; center sleeve</li> <li>Leveling pads</li> <li>Rear splash guard</li> <li>Coolant system</li> <li>Work light</li> <li>Tools &amp; tool box</li> </ul>	<ul style="list-style-type: none"> <li>Z axis rapid traverse</li> <li>3-jaw &amp; 4-jaw chuck</li> <li>Face plate</li> <li>Steady rest</li> <li>Driving plate</li> <li>Rear cutter rest</li> <li>Micrometer carriage stop</li> <li>4-position carriage stop</li> <li>Live center</li> <li>Enlarged spindle bore</li> <li>Enlarged motor</li> <li>Change gears</li> <li>5C collet attachment</li> <li>American toolpost</li> <li>Quick change toolpost</li> <li>Taper turning attachment</li> <li>Hydraulic copying attachment</li> <li>Chip guard</li> <li>Chuck guard</li> <li>ID/OD grinder</li> <li>Digital readout</li> <li>CE &amp; CSA standard</li> </ul>

### BMT 2240MA / BMT 2260MA BMT 2280MA / BMT 22120MA

STANDARD ACCESSORIES	OPTIONAL ACCESSORIES
<ul style="list-style-type: none"> <li>Back plate</li> <li>4-way toolpost</li> <li>Gap bed</li> <li>Motor &amp; electric control system</li> <li>Thread dial indicator</li> <li>Low voltage control system</li> <li>Dead center &amp; center sleeve</li> <li>Leveling pads</li> <li>Coolant system</li> <li>Tools &amp; tool box</li> </ul>	<ul style="list-style-type: none"> <li>Z-axis rapid traverse</li> <li>3-jaw &amp; 4-jaw chuck</li> <li>Face plate</li> <li>Steady rest &amp; Follow rest</li> <li>Taper turning attachment</li> <li>Quick change toolpost</li> <li>Chuck guard</li> <li>Chip guard</li> <li>Full length splash guard</li> <li>Leadscrew cover</li> <li>Electromagnetic brake</li> <li>Micrometer carriage stop</li> <li>Live center</li> <li>LED lamp</li> <li>CE &amp; CSA standard</li> </ul>

## ▼ BMT 2240MA / BMT 2260MA / BMT 2280MA / BMT 22120MA



· Machines shown with optional accessories.

### SPECIFICATION:

Description	BMT 2280L	BMT 2280MA	BMT 2290M	BMT 22100L	BMT 22120MA	BMT 22120L	BMT 22160L
Swing over bed	560 mm						
Swing over cross slide	340 mm	390 mm	340 mm		390 mm		340 mm
Swing over gap	788 mm	810 mm	788 mm		810 mm		788 mm
Center height	280 mm						
Distance between centers	2000 mm		2200 mm	2500 mm	3000 mm	3300 mm	4300 mm
Bed width	400 mm	345 mm	350 mm	400 mm	345 mm		400 mm
Compound rest travel	200 mm	130 mm	200 mm		130 mm		200 mm
Cross slide travel	375 mm	265 mm	300 mm	375 mm	265 mm		375 mm
Spindle nose	D1-8 / D1-11 (opt.)		D1-8		D1-8 / D1-11 (opt.)		D1-8
Spindle bore	85 mm / 120 mm (opt.)	80 mm	85 mm / 105 mm (opt.)		80 mm	85 mm / 120 mm (opt.)	
Taper of spindle bore	MT 7						
Spindle speed	12 steps / 15~1500 rpm	16 steps / 20~1600 rpm Vari. speeds / 16~2000 rpm (opt.)	12 steps / 15~1500 rpm		16 steps / 20~1600 rpm Vari. speeds / 16~2000 rpm (opt.)	12 steps / 15~1500 rpm	
Taper of tailstock	MT 5						
Tailstock quill travel	165 mm	180 mm	165 mm		180 mm	165 mm	
Tailstock quill diameter	85 mm	75 mm		85 mm	75 mm	85 mm	
Main motor	10 HP / 15 HP (opt.)	10 HP / 12.5 HP (opt.)	7.5 HP / 10 HP (opt.)	10 HP / 15 HP (opt.)	12.5 HP	10 HP / 15 HP (opt.)	
Coolant pump motor	1/8 HP						
Machine size (L x W x H)	3470 x 1030 x 1260 mm	3254 x 1086 x 1375 mm	3530 x 990 x 1250 mm	3980 x 1030 x 1260 mm	4254 x 1086 x 1375 mm	4730 x 1030 x 1260 mm	5550 x 1030 x 1260 mm
Machine packing size (L x W x H)	3610 x 1150 x 1930 mm	3455 x 1100 x 1830 mm	3610 x 1150 x 1700 mm	4260 x 1150 x 1930 mm	4470 x 1100 x 1830 mm	4850 x 1150 x 1930 mm	5880 x 1150 x 1930 mm
Net weight (approx.)	2900 kgs	2700 kgs	2750 kgs	3150 kgs	3700 kgs	3650 kgs	4860 kgs
Gross weight (approx.)	3050 kgs	3050 kgs	2900 kgs	3300 kgs	4200 kgs	3800 kgs	5060 kgs

\*Specifications are subject to change without prior notice.

### BMT 2240L / BMT 2260L / BMT 2280L / BMT 22100L / BMT 22120L / BMT 22160L

STANDARD ACCESSORIES	OPTIONAL ACCESSORIES
<ul style="list-style-type: none"> <li>Z axis rapid traverse for BMT 22100L / BMT 22120L / BMT 22160L</li> <li>3-jaw chuck</li> <li>Back plate</li> <li>Steady rest &amp; Follow rest</li> <li>4-way toolpost</li> <li>Screw wrench for cutter setting</li> <li>Auto-feed stopper ring</li> </ul>	<ul style="list-style-type: none"> <li>Dead center &amp; center sleeve</li> <li>Leveling pads</li> <li>Rear splash guard</li> <li>Coolant system</li> <li>Work light</li> <li>Tools &amp; tool box</li> <li>One piece bed, floor type casting for BMT 22120L / BMT 22160L</li> <li>X axis rapid traverse for BMT 22100L / BMT 22120L / BMT 22160L</li> <li>X/Z axis rapid traverse for BMT 2240L / BMT 2260L / BMT 2280L</li> <li>3-jaw &amp; 4-jaw chuck</li> <li>Face plate</li> <li>Steady rest</li> <li>Driving plate</li> <li>Rear cutter rest</li> <li>Micrometer carriage stop</li> <li>4-position carriage stop</li> <li>Live center</li> <li>Enlarged spindle bore</li> <li>Enlarged motor</li> <li>Change gears</li> <li>5C collet attachment</li> <li>American toolpost</li> <li>Quick change toolpost</li> <li>Taper turning attachment</li> <li>Hydraulic copying attachment</li> <li>Chip guard</li> <li>Chuck guard</li> <li>ID/OD grinder</li> <li>Digital readout</li> <li>CE &amp; CSA standard</li> </ul>

## 16.SWING OVER BED 600 MM

▼ BMT 3A2460 / BMT 3A24120 / BMT 3A24160 / BMT 3A24200



▼ BMT 3A2480



▲ The 3rd rail (auxiliary guideway) enhances the cutting force

▲ Longitudinal stop device

· Machines shown with optional accessories.

### OPTIONAL ACCESSORIES:



▲ Powerful apron, carriage with rapid traverse & controls



▲ Double chuck



▲ Hydraulic copy device (Templates are made by customers.)



▲ Quick change toolpost

### SPECIFICATION:

Description	BMT 3A2460	BMT 3A2480	BMT 3A24120	BMT 3A24160	BMT 3A24200
Swing over bed	600 mm				
Swing over cross slide	390 mm				
Swing over gap	820 mm				
Center height	300 mm				
Distance between centers	1500 mm	2000 mm	3000 mm	4000 mm	5000 mm
Bed width	400 mm				
Compound rest travel	230 mm				
Cross slide travel	300 mm				
Spindle nose	A1-8, D1-8 / A2-11, D1-11 (opt.)				
Spindle bore	80 mm / 104 mm (opt.)				
Taper of spindle bore	MT 4				
Spindle speed	12 steps / 17~1200 rpm				
Taper of tailstock	MT 5				
Tailstock quill travel	230 mm				
Tailstock quill diameter	80 mm				
Main motor	15 HP				
Coolant pump motor	1/8 HP				
Machine size (L x W x H)	2890 x 1420 x 1475 mm	3390 x 1420 x 1475 mm	4390 x 1420 x 1475 mm	5390 x 1420 x 1475 mm	6390 x 1420 x 1475 mm
Machine packing size (L x W x H)	3150 x 1370 x 1790 mm	3650 x 1370 x 1790 mm	4650 x 1370 x 1790 mm	5650 x 1370 x 1790 mm	6650 x 1370 x 1790 mm
Net weight (approx.)	2750 kgs	2950 kgs	3500 kgs	4050 kgs	4700 kgs
Gross weight (approx.)	3000 kgs	3250 kgs	3850 kgs	4500 kgs	5250 kgs

\*Specifications are subject to change without prior notice.

### BMT 3A2460 / BMT 3A2480 / BMT 3A24120 / BMT 3A24160 / BMT 3A24200

#### ■ STANDARD ACCESSORIES

- X/Z axis rapid traverse
- 4-way toolpost
- Auto lubrication system
- Dead center & center sleeve
- Leveling pads
- Tailstock center
- Meter/inch community gear box
- Independent electrical box
- Coolant system
- Tools & tool box

#### ■ OPTIONAL ACCESSORIES

- 3-jaw & 4-jaw chuck
- Face plate
- Steady rest & Follow rest
- Rear toolpost
- Taper turning attachment
- Live center
- Quick change toolpost
- Micrometer carriage stop
- Turret type 4-position bed stopper
- Boring attachment
- Grinding attachment
- Splash guard
- Chuck guard
- Digital readout
- Work light
- CE & CSA standard

## 17.SWING OVER BED 610 MM & 630 MM

### ▼ BMT 2480SM / BMT 24120SM / BMT 24160SM

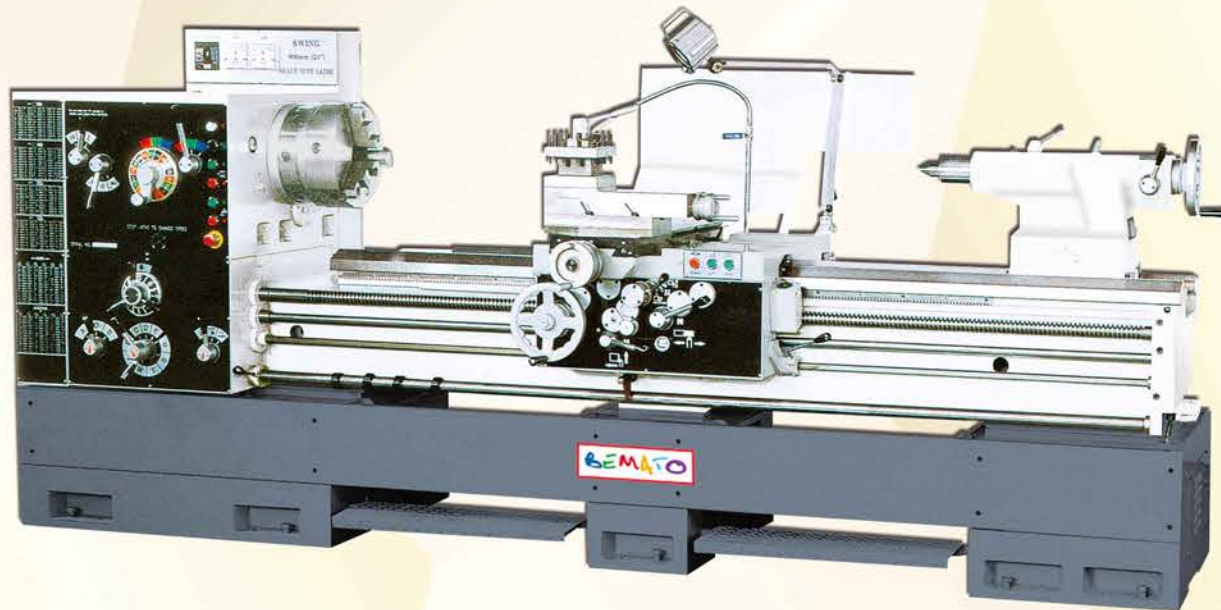

### ▼ BMT 2540M / BMT 2560M / BMT 2580M / BMT 25120M



· Machines shown with optional accessories.

### FOR BMT 2540M / BMT 2560M / BMT 2580M / BMT 25120M:



▲ Conventional Type



▲ Inverter Type (OPT.)

### SPECIFICATION:

Description	BMT 2480SM	BMT 24120SM	BMT 24160SM	BMT 2540M	BMT 2560M	BMT 2580M	BMT 25120M
Swing over bed	610 mm			630 mm			
Swing over cross slide	350 mm			450 mm			
Swing over gap	820 mm			810 mm (opt.)			
Center height	305 mm			315 mm			
Distance between centers	2033 mm	3050 mm	4050 mm	1000 mm	1500 mm	2000 mm	3000 mm
Bed width	485 mm			350 mm			
Compound rest travel	375 mm			150 mm			
Cross slide travel	375 mm			330 mm			
Spindle nose	D1-11			D1-8 / A 2-11 (opt.)			
Spindle bore	105 mm			85 mm / 105 / 155 mm (opt.)			
Taper of spindle bore	MT 5			-			
Spindle speed	18 steps / 10~1200 rpm			18 steps / 25~1545 rpm Vari. speeds / 27~2250 rpm (opt.)			
Taper of tailstock				MT 5			
Tailstock quill travel	195 mm			170 mm			
Tailstock quill diameter	80 mm			75 mm			
Main motor	15 HP			10 HP / 15 HP (opt.)			
Coolant pump motor				1/8 HP			
Machine size (L x W x H)	3570 x 1467 x 1500 mm	4790 x 1467 x 1500 mm	5790 x 1467 x 1500 mm	2390 x 1150 x 1945 mm	2890 x 1150 x 1945 mm	3390 x 1150 x 1945 mm	4390 x 1150 x 1945 mm
Machine packing size (L x W x H)	3760 x 1570 x 1850 mm	4800 x 1570 x 1850 mm	5870 x 1200 x 1850 mm	2290 x 1200 x 1700 mm	2790 x 1200 x 1700 mm	3290 x 1200 x 1700 mm	4290 x 1200 x 1700 mm
Net weight (approx.)	3500 kgs	4000 kgs	4500 kgs	2300 kgs	2550 kgs	2700 kgs	2800 kgs
Gross weight (approx.)	3800 kgs	4300 kgs	4800 kgs	-			

\*Specifications are subject to change without prior notice.

#### BMT 2480SM / BMT 24120SM / BMT 24160SM

##### ■ STANDARD ACCESSORIES

- Back plate
- Steady rest
- 4-way toolpost
- 4-way rapid traverse
- 4-position carriage stop
- 2 speed feed tailstock
- Thread dial indicator
- Change gears
- Dead center & center sleeve
- Leveling pads
- Universal gear box
- Foot brake & emergency stop
- Auto lubrication system
- Electromagnetic brake
- Coolant system
- Tools & tool box

##### ■ OPTIONAL ACCESSORIES

- 3-jaw & 4-jaw chuck
- Face plate
- Steady rest & Follow rest
- Enlarged motor
- Taper turning attachment
- Quick change toolpost
- Live center
- Drill chuck & arbor
- Splash guard
- Chuck guard
- Toolpost guard
- Digital readout
- Halogen lamp
- CE & CSA standard

#### BMT 2540M / BMT 2560M BMT 2580M / BMT 25120M

##### ■ STANDARD ACCESSORIES

- 4-way toolpost
- Dead center & center sleeve
- Coolant system
- Tools & tool box

##### ■ OPTIONAL ACCESSORIES

- Z-axis rapid traverse
- 3-jaw & 4-jaw chuck
- Face plate
- Steady rest & Follow rest
- Gap bed
- Enlarged spindle bore
- Electromagnetic brake
- Inverter driven
- Quick change toolpost
- Taper turning attachment
- Full length splash guard
- Leadscrew guard
- Micrometer carriage stop
- Turret type 5 position bed stopper
- Live center
- Digital readout
- Halogen lamp
- CE standard

## 18. SWING OVER BED 660 MM

▼ BMT 2640M / BMT 2660M / BMT 2690M



▼ BMT 2640L / BMT 2660L / BMT 2680L  
BMT 26100L / BMT 26120L / BMT 26160L



· Machines shown with optional accessories.

### SPECIFICATION:

Description	BMT 2640M	BMT 2640L	BMT 2660M	BMT 2660L	BMT 2660J	BMT 2680L	BMT 2680J
Swing over bed	660 mm						
Swing over cross slide	440 mm			470 mm			
Swing over gap	890 mm			860 mm			
Center height	330 mm						
Distance between centers	1000 mm			1500 mm		2000 mm	
Bed width	350 mm	400 mm	350 mm	400 mm	480 mm	400 mm	480 mm
Compound rest travel	200 mm				190 mm	200 mm	190 mm
Cross slide travel	300 mm	375 mm	300 mm	375 mm	390 mm	375 mm	390 mm
Spindle nose	D1-8	D1-8 / D1-11 (opt.)	D1-8	D1-8 / D1-11 (opt.)	D1-11 / A2-11 (opt.)	D-8 / D1-11 (opt.)	D1-11 / A2-11 (opt.)
Spindle bore	85 mm / 105 mm (opt.)	85 mm / 120 mm (opt.)	85 mm / 105 mm (opt.)	85 mm / 120 mm (opt.)	104 mm	85 mm / 120 mm (opt.)	104 mm
Taper of spindle bore	MT 7						
Spindle speed	12 steps / 15~1500 rpm				Vari. speeds / 20~1800 rpm	12 steps / 15~1500 rpm	Vari. speeds / 20~1800 rpm
Taper of tailstock	MT 5				MT 6	MT 5	MT 6
Tailstock quill travel	165 mm				300 mm	195 mm	300 mm
Tailstock quill diameter	75 mm	85 mm	75 mm	85 mm	105 mm	80 mm	105 mm
Main motor	7.5 HP / 10 HP (opt.)	10 HP / 15 HP (opt.)	7.5 HP / 10 HP (opt.)	10 HP / 15 HP (opt.)	20 HP / 30 HP (opt.)	10 HP / 15 HP (opt.)	20 HP / 30 HP (opt.)
Coolant pump motor	1/8 HP				1/4 HP	1/8 HP	1/4 HP
Machine size (L x W x H)	2290 x 990 x 1300 mm	2380 x 1030 x 1310 mm	2780 x 990 x 1300 mm	2900 x 1030 x 1310 mm	3900 x 2000 x 1700 mm	3470 x 1030 x 1310 mm	4425 x 2000 x 1700 mm
Machine packing size (L x W x H)	2380 x 1150 x 1700 mm	2520 x 1150 x 1930 mm	2900 x 1150 x 1700 mm	3150 x 1150 x 1930 mm	3620 x 1940 x 2250 mm	3610 x 1150 x 1930 mm	4120 x 1940 x 2250 mm
Net weight (approx.)	2250 kgs	2280 kgs	2450 kgs	2630 kgs	3800 kgs	2980 kgs	4300 kgs
Gross weight (approx.)	2400 kgs	2380 kgs	2600 kgs	2730 kgs	4300 kgs	3130 kgs	5000 kgs

\*Specifications are subject to change without prior notice.

### BMT 2640M / BMT 2660M / BMT 2690M

- |  |   |  |
|--|---|--|
| <b>STANDARD ACCESSORIES</b> <ul style="list-style-type: none"> <li>3-jaw chuck</li> <li>Back plate</li> <li>Steady rest &amp; Follow rest</li> <li>4-way toolpost</li> <li>Screw wrench for cutter setting</li> <li>Auto-feed stopper ring</li> <li>Dead center &amp; center sleeve</li> <li>Leveling pads</li> <li>Rear splash guard</li> <li>Coolant system</li> <li>Work light</li> <li>Tools &amp; tool box</li> </ul> | <b>OPTIONAL ACCESSORIES</b> <ul style="list-style-type: none"> <li>Z axis rapid traverse</li> <li>3-jaw &amp; 4-jaw chuck</li> <li>Face plate</li> <li>Driving plate</li> <li>Rear cutter rest</li> <li>Micrometer carriage stop</li> <li>4-position carriage stop</li> <li>Live center</li> <li>Enlarged spindle bore</li> <li>Enlarged motor</li> <li>Change gears</li> </ul> | <ul style="list-style-type: none"> <li>5C collet attachment</li> <li>American toolpost</li> <li>Quick change toolpost</li> <li>Taper turning attachment</li> <li>Hydraulic copying attachment</li> <li>Chip guard</li> <li>Chuck guard</li> <li>ID/OD grinder</li> <li>Digital readout</li> <li>CE &amp; CSA standard</li> </ul> |
|--|---|--|

## ▼ BMT 2660J / BMT 2680J / BMT 26120J / BMT 26160J



▲ Bearings on the spindle are imported from Germany.

· Machines shown with optional accessories.

### SPECIFICATION:

Description	BMT 2690M	BMT 26100L	BMT 26120J	BMT 26120L	BMT 26160J	BMT 26160L
Swing over bed	660 mm					
Swing over cross slide	440 mm		470 mm	440 mm	470 mm	440 mm
Swing over gap	890 mm		860 mm	890 mm	860 mm	890 mm
Center height	330 mm					
Distance between centers	2200 mm	2500 mm	3000 mm	3300 mm	4000 mm	4300 mm
Bed width	350 mm	400 mm	480 mm	400 mm	480 mm	400 mm
Compound rest travel	200 mm		190 mm	200 mm	190 mm	200 mm
Cross slide travel	300 mm	375 mm	390 mm	375 mm	390 mm	375 mm
Spindle nose	D1-8	D1-8 / D1-11 (opt.)	D1-11 / A2-11 (opt.)	D1-8 / D1-11 (opt.)	D1-11 / A2-11 (opt.)	D1-8 / D1-11 (opt.)
Spindle bore	85 mm / 105 mm (opt.)	85 mm / 120 mm (opt.)	104 mm	85 mm / 120 mm (opt.)	104 mm	85 mm / 120 mm (opt.)
Taper of spindle bore	MT 7					
Spindle speed	12 steps / 15~1500 rpm		Vari. speeds / 20~1800 rpm	12 steps / 15~1500 rpm	Vari. speeds / 20~1800 rpm	12 steps / 15~1500 rpm
Taper of tailstock	MT 5		MT 6	MT 5	MT 6	MT 5
Tailstock quill travel	165 mm		300 mm	165 mm	300 mm	165 mm
Tailstock quill diameter	75 mm	85 mm	105 mm	85 mm	105 mm	85 mm
Main motor	7.5 HP / 10 HP (opt.)	10 HP / 15 HP (opt.)	20 HP / 30 HP (opt.)	10 HP / 15 HP (opt.)	20 HP / 30 HP (opt.)	10 HP / 15 HP (opt.)
Coolant pump motor	1/8 HP		1/4 HP	1/8 HP	1/4 HP	1/8 HP
Machine size (L x W x H)	3530 x 990 x 1300 mm	3980 x 1030 x 1310 mm	5425 x 2000 x 1700 mm	4730 x 1030 x 1310 mm	6425 x 2000 x 1700 mm	5550 x 1030 x 1310 mm
Machine packing size (L x W x H)	3610 x 1150 x 1700 mm	4260 x 1150 x 1930 mm	5120 x 1940 x 2250 mm	4850 x 1150 x 1930 mm	6120 x 1940 x 2250 mm	5880 x 1150 x 1930 mm
Net weight (approx.)	2800 kgs	3230 kgs	5400 kgs	3730 kgs	6500 kgs	4940 kgs
Gross weight (approx.)	2950 kgs	3380 kgs	6000 kgs	3880 kgs	7200 kgs	5140 kgs

\*Specifications are subject to change without prior notice.

### BMT 2640L / BMT 2660L / BMT 2680L BMT 26100L / BMT 26120L / BMT 26160L

- |  |   |  |
|--|---|--|
| <b>STANDARD ACCESSORIES</b> <ul style="list-style-type: none"> <li>Z axis rapid traverse for BMT 26100L / BMT 26120L / BMT 26160L</li> <li>3-jaw chuck</li> <li>Back plate</li> <li>Steady rest &amp; Follow rest</li> <li>4-way toolpost</li> <li>Screw wrench for cutter setting</li> <li>Auto-feed stopper ring</li> <li>Dead center &amp; center sleeve</li> <li>Leveling pads</li> <li>Rear splash guard</li> <li>Coolant system</li> <li>Work light</li> <li>Tools &amp; tool box</li> </ul> | <b>OPTIONAL ACCESSORIES</b> <ul style="list-style-type: none"> <li>One piece bed, floor type casting for BMT 26120L / BMT 26160L</li> <li>X axis rapid traverse for BMT 26100L / BMT 26120L / BMT 26160L</li> <li>X/Z axis rapid traverse for BMT 2640L / BMT 2660L / BMT 2680L</li> <li>3-jaw &amp; 4-jaw chuck</li> <li>Face plate</li> <li>Steady rest</li> <li>Driving plate</li> <li>Rear cutter rest</li> <li>Micrometer carriage stop</li> <li>4-position carriage stop</li> </ul> | <ul style="list-style-type: none"> <li>Live center</li> <li>Enlarged spindle bore</li> <li>Enlarged motor</li> <li>Change gears</li> <li>5C collet attachment</li> <li>American toolpost</li> <li>Quick change toolpost</li> <li>Taper turning attachment</li> <li>Hydraulic copying attachment</li> <li>Chip guard</li> <li>Chuck guard</li> <li>ID/OD grinder</li> <li>Digital readout</li> <li>CE &amp; CSA standard</li> </ul> |
|--|---|--|

### BMT 2660J / BMT 2680J BMT 26120J / BMT 26160J

- |  |  |
|--|--|
| <b>STANDARD ACCESSORIES</b> <ul style="list-style-type: none"> <li>X/Y axis rapid traverse</li> <li>Back plate</li> <li>Gap bed</li> <li>Motor &amp; electric control system</li> <li>Thread dial indicator</li> <li>Low voltage control system</li> <li>Dead center &amp; center sleeve</li> <li>Leveling pads</li> <li>Full length splash guard</li> <li>Leadscrew cover</li> <li>Inverter brake system</li> <li>Coolant system</li> <li>Tools &amp; tool box</li> </ul> | <b>OPTIONAL ACCESSORIES</b> <ul style="list-style-type: none"> <li>3-jaw &amp; 4-jaw chuck</li> <li>Steady rest &amp; Follow rest</li> <li>Taper turning attachment</li> <li>Quick change toolpost</li> <li>Chip guard</li> <li>Live center</li> <li>Micrometer carriage stop</li> <li>LED light</li> <li>CE &amp; CSA standard</li> </ul> |
|--|--|

## 19.SWING OVER BED 670 MM

▼ BMT 3A2660 / BMT 3A2680 / BMT 3A26120 / BMT 3A26160 / BMT 3A26200



### SPECIFICATION:

· Machines shown with optional accessories.

Description	BMT 3A2660	BMT 3A2660W	BMT 3A2680	BMT 3A2680W	BMT 3A26120
Swing over bed	670 mm				
Swing over cross slide	460 mm				
Swing over gap	890 mm				
Center height	335 mm				
Distance between centers	1500 mm		2000 mm		3000 mm
Bed width	400 mm	460 mm	400 mm	460 mm	400 mm
Compound rest travel	230 mm				
Cross slide travel	300 mm	385 mm	300 mm	385 mm	300 mm
Spindle nose	A1-8, D1-8 / A2-11, D1-11 (opt.)	A2-11, D1-11 / A2-15 (opt.)	A1-8, D1-8 / A2-11, D1-11 (opt.)	A2-11, D1-11 / A2-15 (opt.)	A1-8, D1-8 / A2-11, D1-11 (opt.)
Spindle bore	80 mm / 104 mm (opt.)	104 mm / 156 / 230 mm (opt.)	80 mm / 104 mm (opt.)	104 mm / 156 / 230 mm (opt.)	80 mm / 104 mm (opt.)
Taper of spindle bore	MT 4 / MT 5 (opt.)	MT 5 / MT 6 (opt.)	MT 4 / MT 5 (opt.)	MT 5 / MT 6 (opt.)	MT 4 / MT 5 (opt.)
Spindle speed	12 steps / 17~1200 rpm	12 steps / 15~1000 rpm	12 steps / 17~1200 rpm	12 steps / 15~1000 rpm	12 steps / 17~1200 rpm
Taper of tailstock	MT 5				
Tailstock quill travel	230 mm				
Tailstock quill diameter	80 mm	95 mm	80 mm	95 mm	80 mm
Main motor	15 HP	15 HP / 20 HP (opt.)	15 HP	15 HP / 20 HP (opt.)	15 HP
Coolant pump motor	1/8 HP				
Machine size (L x W x H)	2890 x 1420 x 1540 mm	3130 x 1420 x 1540 mm	3390 x 1420 x 1540 mm	3630 x 1420 x 1540 mm	4390 x 1420 x 1540 mm
Machine packing size (L x W x H)	3150 x 1370 x 1790 mm	3300 x 1370 x 1870 mm	3650 x 1370 x 1790 mm	3800 x 1370 x 1870 mm	4650 x 1370 x 1790 mm
Net weight (approx.)	2850 kgs	2950 kgs	3050 kgs	3150 kgs	3600 kgs
Gross weight (approx.)	3100 kgs	3200 kgs	3350 kgs	3450 kgs	3950 kgs

\*Specifications are subject to change without prior notice.

## ▼ BMT 3A2660W / BMT 3A2680W / BMT 3A26120W / BMT 3A26160W / BMT 3A26200W



### SPECIFICATION:

· Machines shown with optional accessories.

Description	BMT 3A26120W	BMT 3A26160	BMT 3A26160W	BMT 3A26200	BMT 3A26200W
Swing over bed	670 mm				
Swing over cross slide	460 mm				
Swing over gap	890 mm				
Center height	335 mm				
Distance between centers	3000 mm	4000 mm		5000 mm	
Bed width	460 mm	400 mm	460 mm	400 mm	460 mm
Compound rest travel	230 mm				
Cross slide travel	385 mm	300 mm	385 mm	300 mm	385 mm
Spindle nose	A2-11, D1-11 / A2-15 (opt.)	A1-8, D1-8 / A2-11, D1-11 (opt.)	A2-11, D1-11 / A2-15 (opt.)	A1-8, D1-8 / A2-11, D1-11 (opt.)	A2-11, D1-11 / A2-15 (opt.)
Spindle bore	104 mm / 156 / 230 mm (opt.)	80 mm / 104 mm (opt.)	104 mm / 156 / 230 mm (opt.)	80 mm / 104 mm (opt.)	104 mm / 156 / 230 mm (opt.)
Taper of spindle bore	MT 5 / MT 6 (opt.)	MT 4 / MT 5 (opt.)	MT 5 / MT 6 (opt.)	MT 4 / MT 5 (opt.)	MT 5 / MT 6 (opt.)
Spindle speed	12 steps / 15~1000 rpm	12 steps / 17~1200 rpm	12 steps / 15~1000 rpm	12 steps / 17~1200 rpm	12 steps / 15~1000 rpm
Taper of tailstock	MT 5				
Tailstock quill travel	230 mm				
Tailstock quill diameter	95 mm	80 mm	95 mm	80 mm	95 mm
Main motor	15 HP / 20 HP (opt.)	15 HP	15 HP / 20 HP (opt.)	15 HP	15 HP / 20 HP (opt.)
Coolant pump motor	1/8 HP				
Machine size (L x W x H)	4630 x 1420 x 1540 mm	5390 x 1420 x 1540 mm	5630 x 1420 x 1540 mm	6390 x 1420 x 1540 mm	6630 x 1420 x 1540 mm
Machine packing size (L x W x H)	4800 x 1370 x 1870 mm	5650 x 1370 x 1790 mm	5800 x 1370 x 1870 mm	6650 x 1370 x 1790 mm	6800 x 1370 x 1870 mm
Net weight (approx.)	3700 kgs	4150 kgs	4250 kgs	4800 kgs	4900 kgs
Gross weight (approx.)	4050 kgs	4600 kgs	4700 kgs	5350 kgs	5450 kgs

\*Specifications are subject to change without prior notice.

### ALL BMT 3A26 SERIES

- |   |   |   |
|---|---|---|
| <ul style="list-style-type: none"> <li>■ STANDARD ACCESSORIES</li> <li>· X/Z axis rapid traverse</li> <li>· 4-way toolpost</li> <li>· Auto lubrication system</li> <li>· Dead center &amp; center sleeve</li> <li>· Leveling pads</li> <li>· Tailstock center</li> <li>· Meter/inch community gear box</li> <li>· Independent electrical box</li> <li>· Coolant system</li> <li>· Tools &amp; tool box</li> </ul> | <ul style="list-style-type: none"> <li>■ OPTIONAL ACCESSORIES</li> <li>· 3-jaw &amp; 4-jaw chuck</li> <li>· Face plate</li> <li>· Steady rest &amp; Follow rest</li> <li>· Rear toolpost</li> <li>· Taper turning attachment</li> <li>· Live center</li> <li>· Quick change toolpost</li> </ul> | <ul style="list-style-type: none"> <li>· Micrometer carriage stop</li> <li>· Turret type 4-position carriage stop</li> <li>· Boring attachment</li> <li>· Grinding attachment</li> <li>· Splash guard &amp; Chip guard</li> <li>· Digital readout</li> <li>· Work light</li> <li>· CE &amp; CSA standard</li> </ul> |
|---|---|---|

# CONVENTIONAL LATHE



## 20.SWING OVER BED 760 MM

▼ **BMT 3040L / BMT 3060L / BMT 3080L**  
**BMT 30100L / BMT 30120L / BMT 30160L**



▼ **BMT 3060J / BMT 3080J**  
**BMT 30120J / BMT 30160J**



· Machines shown with optional accessories.

### SPECIFICATION:

Description	BMT 3040L	BMT 3060L	BMT 3060J	BMT 3080L	BMT 3080J	BMT 3080SM	BMT 30100L
Swing over bed	760 mm						
Swing over cross slide	540 mm		570 mm	540 mm	570 mm	500 mm	540 mm
Swing over gap	990 mm		960 mm	990 mm	960 mm	970 mm	990 mm
Center height	380 mm						
Distance between centers	1000 mm	1500 mm		2000 mm		2033 mm	2500 mm
Bed width	400 mm		480 mm	400 mm	480 mm	485 mm	400 mm
Compound rest travel	200 mm		190 mm	200 mm	190 mm	375 mm	200 mm
Cross slide travel	375 mm		390 mm	375 mm	390 mm	375 mm	
Spindle nose	D1-11		D1-11 / A2-11 (opt.)	D1-11	D1-11 / A2-11 (opt.)	D1-11	
Spindle bore	120 mm		104 mm	120 mm	104 mm	105 mm	120 mm
Taper of spindle bore	MT 7					MT 5	MT 7
Spindle speed	12 steps / 15~1500 rpm		Vari. speeds / 20~1800 rpm	12 steps / 15~1500 rpm	Vari. speeds / 20~1800 rpm	18 steps / 10~1200 rpm	12 steps / 15~1500 rpm
Taper of tailstock	MT 5		MT 6	MT 5	MT 6	MT 5	
Tailstock quill travel	165 mm		300 mm	165 mm	300 mm	195 mm	165 mm
Tailstock quill diameter	85 mm		105 mm	85 mm	105 mm	80 mm	85 mm
Main motor	15 HP		20 HP / 30 HP (opt.)	15 HP	20 HP / 30 HP (opt.)	15 HP	
Coolant pump motor	1/8 HP		1/4 HP	1/8 HP	1/4 HP	1/8 HP	
Machine size (L x W x H)	2380 x 1030 x 1370 mm	2900 x 1030 x 1370 mm	3900 x 2000 x 1955 mm	3470 x 1030 x 1370 mm	4425 x 2000 x 1955 mm	3570 x 1467 x 1575 mm	3980 x 1030 x 1370 mm
Machine packing size (L x W x H)	2520 x 1150 x 1930 mm	3000 x 1150 x 1930 mm	3620 x 1940 x 2250 mm	3610 x 1150 x 1930 mm	4120 x 1940 x 2250 mm	3760 x 1575 x 1930 mm	4260 x 1150 x 1930 mm
Net weight (approx.)	2360 kgs	2710 kgs	4000 kgs	3060 kgs	4500 kgs	3800 kgs	3310 kgs
Gross weight (approx.)	2460 kgs	2810 kgs	4500 kgs	3210 kgs	5200 kgs	4100 kgs	3460 kgs

\*Specifications are subject to change without prior notice.

### BMT 3040L / BMT 3060L / BMT 3080L / BMT 30100L / BMT 30120L / BMT 30160L

#### STANDARD ACCESSORIES

- Z axis rapid traverse for BMT 30100L / BMT 30120L / BMT 30160L
- 3-jaw chuck
- Back plate
- Steady rest & Follow rest
- 4-way toolpost
- Screw wrench for cutter setting
- Auto-feed stopper ring
- Dead center & center sleeve
- Leveling pads
- Rear splash guard
- Coolant system
- Work light
- Tools & tool box

#### OPTIONAL ACCESSORIES

- One piece bed, floor type casting for BMT 30120L / BMT 30160L
- X axis rapid traverse for BMT 30100L / BMT 30120L / BMT 30160L
- X/Z axis rapid traverse for BMT 3040L / BMT 3060L / BMT 3080L
- 3-jaw & 4-jaw chuck
- Face plate
- Steady rest
- Driving plate
- Rear cutter rest
- Micrometer carriage stop
- 4-position carriage stop
- Live center
- Enlarged spindle bore
- Enlarged motor
- Change gears
- 5C collet attachment
- American toolpost
- Quick change toolpost
- Taper turning attachment
- Hydraulic copying attachment
- Chip guard
- Chuck guard
- ID/OD grinder
- Digital readout
- CE & CSA standard

## ▼ BMT 3080SM / BMT 30120SM / BMT 30160SM



· Machines shown with optional accessories.



▲ Automatic lubrication system



▲ Electro-magnetic clutch & brake



▲ Four-way rapid carriage movement



▲ Multiple threading system for cutting wormhas two-speed feed



▲ Tailstock hand-wheel



▲ Width of bed ways 19inch, 485mm

### SPECIFICATION:

Description	BMT 30120J	BMT 30120SM	BMT 30120L	BMT 30160J	BMT 30160SM	BMT 30160L
Swing over bed	760 mm					
Swing over cross slide	570 mm	500 mm	540 mm	570 mm	500 mm	540 mm
Swing over gap	960 mm	970 mm	990 mm	960 mm	970 mm	990 mm
Center height	380 mm					
Distance between centers	3000 mm	3050 mm	3300 mm	4000 mm	4050 mm	4300 mm
Bed width	480 mm	485 mm	400 mm	480 mm	485 mm	400 mm
Compound rest travel	190 mm	375 mm	200 mm	190 mm	375 mm	200 mm
Cross slide travel	390 mm	375 mm		390 mm	375 mm	
Spindle nose	D1-11 / A2-11 (opt.)		D1-11	D1-11 / A2-11 (opt.)		D1-11
Spindle bore	104 mm	105 mm	120 mm	104 mm	105 mm	120 mm
Taper of spindle bore	MT 7	MT 5	MT 7		MT 5	MT 7
Spindle speed	Vari. speeds / 20~1800 rpm		18 steps / 10~1200 rpm	12 steps / 15~1500 rpm	Vari. speeds / 20~1800 rpm	18 steps / 10~1200 rpm
Taper of tailstock	MT 6		MT 5	MT 6		MT 5
Tailstock quill travel	300 mm	195 mm	165 mm	300 mm	195 mm	165 mm
Tailstock quill diameter	105 mm	80 mm	85 mm	105 mm	80 mm	85 mm
Main motor	20 HP / 30 HP (opt.)		15 HP	20 HP / 30 HP (opt.)		15 HP
Coolant pump motor	1/4 HP		1/8 HP	1/4 HP		1/8 HP
Machine size (L x W x H)	5424 x 2000 x 1955 mm	4790 x 1467 x 1575 mm	4730 x 1030 x 1370 mm	6425 x 2000 x 1955 mm	4790 x 1467 x 1575 mm	5550 x 1030 x 1370 mm
Machine packing size (L x W x H)	5120 x 1940 x 2250 mm	4810 x 1575 x 1930 mm	4850 x 1150 x 1930 mm	6120 x 1940 x 2250 mm	5870 x 1575 x 1930 mm	5880 x 1150 x 1930 mm
Net weight (approx.)	5600 kgs	4300 kgs	3810 kgs	6700 kgs	4800 kgs	5020 kgs
Gross weight (approx.)	6200 kgs	4600 kgs	3960 kgs	7400 kgs	5100 kgs	5220 kgs

\*Specifications are subject to change without prior notice.

### BMT 3060J / BMT 3080J BMT 30120J / BMT 30160J

#### STANDARD ACCESSORIES

- X/Y axis rapid traverse
- Back plate
- Gap bed
- Motor & electric control system
- Thread dial indicator
- Low voltage control system
- Dead center & center sleeve
- Leveling pads
- Full length splash guard
- Leadscrew cover
- Inverter brake system
- Coolant system
- Tools & tool box

#### OPTIONAL ACCESSORIES

- 3-jaw & 4-jaw chuck
- Steady rest & Follow rest
- Taper turning attachment
- Quick change toolpost
- Chuck guard
- Chip guard
- Live center
- Micrometer carriage stop
- LED light
- CE & CSA standard

### BMT 3080SM / BMT 30120SM / BMT 30160SM

#### STANDARD ACCESSORIES

- Back plate
- Steady rest
- 4-way toolpost
- 4-way rapid traverse
- 4-position carriage stop
- 2 speed feed tailstock
- Main motor
- Thread dial indicator
- Change gears
- Dead center & center sleeve
- Leveling pads
- Universal gear box
- Foot brake & emergency stop
- Auto lubrication system
- Electromagnetic brake
- Coolant system
- Tools & tool box

#### OPTIONAL ACCESSORIES

- 3-jaw & 4-jaw chuck
- Face plate
- Follow rest
- Enlarged motor
- Taper turning attachment
- Quick change toolpost
- Live center
- Drill chuck & arbor
- Splash guard
- Chuck guard
- Toolpost guard
- Digital readout
- Halogen lamp
- CE & CSA standard

## 21.SWING OVER BED 770 MM

▼ **BMT 3A3060 / BMT 3A3080 / BMT 3A30120**  
**BMT 3A30160 / BM 3A30200**



▼ **BMT 3A3060W / BMT 3A3080W / BMT 3A30120W**  
**BMT 3A30160W / BMT 3A30200W**



· Machines shown with optional accessories.

### SPECIFICATION:

Description	BMT 3A3060	BMT 3A3060W	BMT 3060M	BMT 3A3080	BMT 3A3080W	BMT 3080M	BMT 3A30120	BMT 3A30120W
Swing over bed	770 mm							
Swing over cross slide	560 mm		520 mm	560 mm		520 mm	560 mm	
Swing over gap	990 mm		1010 mm (opt.)	990 mm		1010 mm (opt.)	990 mm	
Center height	385 mm							
Distance between centers	1500 mm		1600 mm	2000 mm		2100 mm	3000 mm	
Bed width	400 mm	460 mm	450 mm	400 mm	460 mm	450 mm	400 mm	460 mm
Compound rest travel	230 mm		250 mm	230 mm		250 mm	230 mm	
Cross slide travel	385 mm	435 mm	450 mm	385 mm	435 mm	450 mm	385 mm	435 mm
Spindle nose	A1-8, D1-8 / A2-11, D1-11 (opt.)	A2-11, D1-11 / A2-15	A2-11	A1-8, D1-8 / A2-11, D1-11 (opt.)	A2-11, D1-11 / A2-15	A2-11	A1-8, D1-8 / A2-11, D1-11 (opt.)	A2-11, D1-11 / A2-15
Spindle bore	80 mm / 104 mm (opt.)	104 mm / 156 / 230 mm (opt.)	105 mm / 155 mm (opt.)	80 mm / 104 mm (opt.)	104 mm / 156 / 230 mm (opt.)	105 mm / 155 mm (opt.)	80 mm / 104 mm (opt.)	104 mm / 156 / 230 mm (opt.)
Taper of spindle bore	MT 4 / MT 5 (opt.)	MT 5 / MT 6 (opt.)	-	MT 4 / MT 5 (opt.)	MT 5 / MT 6 (opt.)	-	MT 4 / MT 5 (opt.)	MT 5 / MT 6 (opt.)
Spindle speed	12 steps / 17~1200 rpm	12 steps / 15~1000 rpm	18 steps / 23~1293 rpm Vari. speeds / 20~1500 rpm (opt.)	12 steps / 17~1200 rpm	12 steps / 15~1000 rpm	18 steps / 23~1293 rpm Vari. speeds / 20~1500 rpm (opt.)	12 steps / 17~1200 rpm	12 steps / 15~1000 rpm
Taper of tailstock	MT 5							
Tailstock quill travel	230 mm		220 mm	230 mm		220 mm	230 mm	
Tailstock quill diameter	80 mm	95 mm	105 mm	80 mm	95 mm	105 mm	80 mm	95 mm
Main motor	15 HP	15 HP / 20 HP (opt.)		15 HP	15 HP / 20 HP (opt.)		15 HP	15 HP / 20 HP (opt.)
Coolant pump motor	1/8 HP							
Machine size (L x W x H)	2890 x 1530 x 1640 mm	3130 x 1530 x 1640 mm	3606 x 800 x 1460 mm	3390 x 1530 x 1640 mm	3630 x 1530 x 1640 mm	4106 x 800 x 1460 mm	4390 x 1530 x 1640 mm	4630 x 1530 x 1640 mm
Machine packing size (L x W x H)	3150 x 1370 x 1840 mm	3300 x 1370 x 1920 mm	3650 x 1700 x 1800 mm	3650 x 1370 x 1840 mm	3800 x 1370 x 1920 mm	4150 x 1700 x 1800 mm	4650 x 1370 x 1840 mm	4800 x 1370 x 1920 mm
Net weight (approx.)	3000 kgs	3100 kgs	3350 kgs	3200 kgs	3300 kgs	3600 kgs	3750 kgs	3850 kgs
Gross weight (approx.)	3250 kgs	3350 kgs	-	3500 kgs	3600 kgs	-	4100 kgs	4200 kgs

\*Specifications are subject to change without prior notice.

### ALL BMT 3A30 SERIES

#### STANDARD ACCESSORIES

- X/Z axis rapid traverse
- 4-way toolpost
- Auto lubrication system
- Dead center & center sleeve
- Leveling pads

- Tailstock center
- Meter/inch community gear box
- Independent electrical box
- Coolant system
- Tools & tool box

#### OPTIONAL ACCESSORIES

- 3-jaw & 4-jaw chuck
- Face plate
- Steady rest & Follow rest
- Rear toolpost
- Taper turning attachment
- Live center
- Quick change toolpost
- Micrometer carriage stop
- Turret type 4-position carriage stop
- Boring attachment & Grinding attachment
- Splash guard & Chip guard
- Digital readout
- Work light
- CE & CSA standard

▼ **BMT 3060M / BMT 3080M / BMT 30120M**  
**BMT 30160M / BMT 30200M / BMT 30240M**



▲ Powerful apron, carriage with rapid traverse & controls

· Machines shown with optional accessories.

### SPECIFICATION:

Description	BMT 30120M	BMT 3A30160	BMT 3A30160W	BMT 30160M	BMT 3A30200	BMT 3A30200W	BMT 30200M	BMT 30240M
Swing over bed	770 mm							
Swing over cross slide	520 mm	560 mm		520 mm	560 mm		520 mm	
Swing over gap	1010 mm (opt.)	990 mm		1010 mm (opt.)	990 mm		1010 mm (opt.)	
Center height	385 mm							
Distance between centers	3100 mm	4000 mm		4100 mm	5000 mm		5100 mm	6100 mm
Bed width	450 mm	400 mm	460 mm	450 mm	400 mm	460 mm		450 mm
Compound rest travel	250 mm	230 mm		250 mm	230 mm			250 mm
Cross slide travel	450 mm	385 mm	435 mm	450 mm	385 mm	435 mm		450 mm
Spindle nose	A2-11	A1-8, D1-8 / A2-11, D1-11 (opt.)	A2-11, D1-11 / A2-15	A2-11	A1-8, D1-8 / A2-11, D1-11 (opt.)	A2-11, D1-11 / A2-15		A2-11
Spindle bore	105 mm / 155 mm (opt.)	80 mm / 104 mm (opt.)	104 mm / 156 / 230 mm (opt.)	105 mm / 155 mm (opt.)	80 mm / 104 mm (opt.)	104 mm / 156 / 230 mm (opt.)		105 mm / 155 mm (opt.)
Taper of spindle bore	-	MT 4 / MT 5 (opt.)	MT 5 / MT 6 (opt.)	-	MT 4 / MT 5 (opt.)	MT 5 / MT 6 (opt.)		-
Spindle speed	18 steps / 23~1293 rpm Vari. speeds / 20~1500 rpm (opt.)	12 steps / 17~1200 rpm	12 steps / 15~1000 rpm	18 steps / 23~1293 rpm Vari. speeds / 20~1500 rpm (opt.)	12 steps / 17~1200 rpm	12 steps / 15~1000 rpm	18 steps / 23~1293 rpm Vari. speeds / 20~1500 rpm (opt.)	18 steps / 23~1293 rpm Vari. speeds / 20~1500 rpm (opt.)
Taper of tailstock	MT 5							
Tailstock quill travel	220 mm	230 mm		220 mm	230 mm		220 mm	
Tailstock quill diameter	105 mm	80 mm	95 mm	105 mm	80 mm	95 mm		105 mm
Main motor	15 HP / 20 HP (opt.)	15 HP		15 HP / 20 HP (opt.)	15 HP		15 HP / 20 HP (opt.)	
Coolant pump motor	1/8 HP							
Machine size (L x W x H)	5106 x 800 x 1460 mm	5390 x 1530 x 1640 mm	5630 x 1530 x 1640 mm	6106 x 800 x 1460 mm	6390 x 1530 x 1640 mm	6630 x 1530 x 1640 mm	7106 x 800 x 1460 mm	8106 x 800 x 1460 mm
Machine packing size (L x W x H)	5150 x 1700 x 1800 mm	5650 x 1370 x 1840 mm	5800 x 1370 x 1920 mm	6150 x 1700 x 1800 mm	6650 x 1370 x 1840 mm	6800 x 1370 x 1920 mm	7150 x 1700 x 1800 mm	8150 x 1700 x 1800 mm
Net weight (approx.)	4100 kgs	4300 kgs	4400 kgs	4600 kgs	4950 kgs	5000 kgs	5100 kgs	5700 kgs
Gross weight (approx.)	-	4750 kgs	4850 kgs	-	5500 kgs	5550 kgs	-	-

\*Specifications are subject to change without prior notice.

### BMT 3060M / BMT 3080M / BMT 30120M / BMT 30160M / BMT 30200M / BMT 30240M

#### STANDARD ACCESSORIES

- X/Z axis rapid traverse
- 4-way toolpost
- Dead center & center sleeve
- Coolant system
- Tools & tool box

#### OPTIONAL ACCESSORIES

- 3-jaw & 4-jaw chuck
- Face plate
- Steady rest & Follow rest
- Gap bed
- Enlarged spindle bore
- Inverter driven

- Quick change toolpost
- Taper turning attachment
- Full length splash guard for BMT 3060M / BMT 3080M / BMT 30120M
- Moving rear splash guard
- Rear connecting plate

- Leadscrew guard
- Micrometer carriage stop
- Turret type 5-position carriage stop
- Live center
- Digital readout
- Halogen lamp
- CE standard



# HEAVY DUTY CONVENTIONAL LATHE



## 22.SWING OVER BED 830 MM & 840 MM

### ▼ BMT 3340L / BMT 3360L / BMT 3380L / BMT 33100L / BMT 33120L / BMT 33160L



### ▼ BMT 3360M / BMT 3380M / BMT 33120M / BMT 33160M / BMT 33200M / BMT 33240M



### ▼ BMT 3A33 / BMT 3A33W



· Machines shown with optional accessories.

### SPECIFICATION:

Description	BMT 3340L / BMT 3360L BMT 3380L / BMT 33100L BMT 33120L / BMT 33160L	BMT 3360M / BMT 3380M BMT 33120M / BMT 33160M BMT 33200M / BMT 33240M	BMT 3A33	BMT 3A33W
Swing over bed	830 mm		840 mm	
Swing over cross slide	610 mm	590 mm	630 mm	
Swing over gap	1060 mm	1080 mm (opt.)	1060 mm	
Center height	415 mm		420 mm	
Distance between centers	1000 / 1500 / 2000 / 2500 / 3300 / 4300 mm	1600 / 2100 / 3100 / 4100 / 5100 / 6100 mm	1500 / 2000 / 3000 / 4000 / 5000 mm	
Bed width	400 mm	450 mm	400 mm	460 mm
Compound rest travel	200 mm	250 mm	230 mm	
Cross slide travel	375 mm	450 mm	385 mm	435 mm
Spindle nose	D1-11	A2-11 / A2-15 (opt.)	A1-8, D1-8 / A2-11, D1-11 (opt.)	
Spindle bore	120 mm	105 mm / 155 / 230 / 255 mm (opt.)	80 mm / 104 mm (opt.)	104 mm / 156 / 230 mm (opt.)
Taper of spindle bore	MT 7	-	MT 4 / MT 5 (opt.)	MT 5 / MT 6 (opt.)
Spindle speed	12 steps / 15~1500 rpm	18 steps / 23~1293 rpm Vari. speeds / 20~1500 rpm (opt.)	12 steps / 17~1200 rpm	12 steps / 15~1000 rpm
Taper of tailstock	MT 5			
Tailstock quill travel	165 mm	220 mm	230 mm	
Tailstock quill diameter	85 mm	105 mm	80 mm	95 mm
Main motor	15 HP	15 HP / 20 HP (opt.)	15 HP	15 HP / 20 HP (opt.)
Coolant pump motor	1/8 HP			
Machine size (L x W x H)	L : 2380 / 2900 / 3470 / 3980 / 4730 / 5550 mm W x H : 1030 x 1410 mm	L : 3606 / 4106 / 5106 / 6106 / 7106 / 8106 mm W x H : 800 x 1495 mm	L : 2890 / 3390 / 4390 / 5390 / 6390 mm W x H : 1530 x 1715 mm	L : 3130 / 3630 / 4630 / 5630 / 6630 mm W x H : 1530 x 1715 mm
Machine packing size (L x W x H)	L : 2520 / 3000 / 3610 / 4260 / 4850 / 5880 mm W x H : 1150 x 1930 mm	L : 3650 / 4150 / 5150 / 6150 / 7150 / 8150 mm W x H : 1700 x 1800 mm	L : 3150 / 3650 / 4650 / 5650 / 6650 mm W x H : 1370 x 1890 mm	L : 3300 / 3800 / 4800 / 5800 / 6800 mm W x H : 1370 x 1970 mm
Net weight (approx.)	2410 / 2760 / 3110 / 3360 / 3860 / 5070 kgs	3450 / 3700 / 4200 / 4700 / 5200 / 5800 kgs	3100 / 3300 / 3850 / 4400 / 5050 kgs	3200 / 3400 / 3950 / 4500 / 5100 kgs
Gross weight (approx.)	2510 / 2860 / 3260 / 3510 / 4010 / 5270 kgs	-	3350 / 3600 / 4200 / 4850 / 5600 kgs	3450 / 3700 / 4300 / 4950 / 5650 kgs

\*Specifications are subject to change without prior notice.

#### BMT 3340L / BMT 3360L / BMT 3380L BMT 33100L / BMT 33120L / BMT 33160L

##### ■ STANDARD ACCESSORIES

- Z axis rapid traverse for BMT 33100L / BMT 33120L / BMT 33160L
- 3-jaw chuck
- Back plate
- Steady rest & Follow rest
- 4-way toolpost
- Screw wrench for cutter setting
- Auto-feed stopper ring
- Dead center & center sleeve
- Leveling pads
- Rear splash guard
- Coolant system
- Work light
- Tools & tool box

##### ■ OPTIONAL ACCESSORIES

- One piece bed, floor type casting for BMT 33120L / BMT 33160L
- X axis rapid traverse for BMT 33100L / BMT 33120L / BMT 33160L
- X/Z axis rapid traverse for BMT 3340L / BMT 3360L / BMT 3380L
- 3-jaw & 4-jaw chuck
- Face plate
- Driving plate
- Rear cutter rest
- Micrometer carriage stop
- 4-position carriage stop
- Live center
- Enlarged spindle bore
- Enlarged motor
- Change gears
- 5C collet attachment
- American toolpost
- Quick change toolpost
- Taper turning attachment
- Hydraulic copying attachment
- Chip guard
- Chuck guard
- ID/OD grinder
- Digital readout
- CE & CSA standard

#### BMT 3360M / BMT 3380M / BMT 33120M BMT 33160M / BMT 33200M / BMT 33240M

##### ■ STANDARD ACCESSORIES

- X/Z axis rapid traverse
- 4-way toolpost
- Dead center & center sleeve
- Coolant system
- Tools & tool box

##### ■ OPTIONAL ACCESSORIES

- 3-jaw & 4-jaw chuck
- Face plate
- Steady rest & Follow rest
- Gap bed
- Enlarged spindle bore
- Inverter driven
- Quick change toolpost
- Taper turning attachment
- Full length splash guard for BMT 3360M / BMT 3380M / BMT 33120M
- Moving rear splash guard
- Rear connecting plate
- Leadscrew guard
- Micrometer carriage stop
- Turret type 5-position carriage stop
- Live center
- Digital readout
- Halogen lamp

#### ALL BMT 3A33 SERIES

##### ■ STANDARD ACCESSORIES

- X/Z axis rapid traverse
- 4-way toolpost
- Auto lubrication system
- Dead center & center sleeve
- Leveling pads
- Tailstock center
- Meter/inch community gear box
- Independent electrical box
- Coolant system
- Tools & tool box

##### ■ OPTIONAL ACCESSORIES

- 3-jaw & 4-jaw chuck
- Face plate
- Steady rest & Follow rest
- Rear toolpost
- Taper turning attachment
- Live center
- Quick change toolpost
- Micrometer carriage stop
- Turret type 4-position carriage stop
- Boring attachment
- Grinding attachment
- Splash guard & Chip guard
- Digital readout
- Work light
- CE & CSA standard

# HEAVY DUTY CONVENTIONAL LATHE



## 23.SWING OVER BED 860 MM & 880 MM

▼ **BMT 3370X / BMT 3390X / BMT 33130X / BMT 33170X**  
**BMT 33210X / BMT 33250X / BMT 33290X / BMT 33330X**



▼ **BMT 35PA**



· Machines shown with optional accessories.

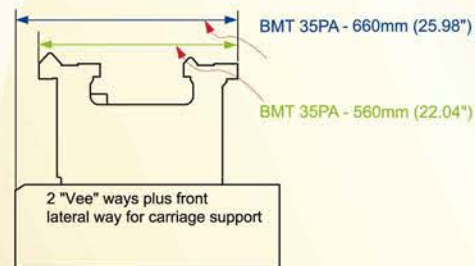

### SPECIFICATION:

Description	BMT 3370X / BMT 3390X / BMT 33130X / BMT 33170X BMT 33210X / BMT 33250X / BMT 33290X / BMT 33330X	BMT 35PA
Swing over bed	860 mm	880 mm
Swing over cross slide	610 mm	615 mm
Swing over gap	1170 mm	-
Center height	430 mm	445 mm
Distance between centers	1810 / 2310 / 3310 / 4310 / 5310 / 6310 / 7310 / 8310 mm	1500 / 2000 / 3000 / 4000 / 5000 / 6000 / 7000 / 8000 / 9000 / 10000 / 11000 / 12000 mm
Bed width	510 mm	560 mm
Compound rest travel	330 mm	450 mm
Cross slide travel	480 mm	670 mm
Spindle nose	A2-11 / A2-15 (opt.)	A2-11 / A2-15-A2-20 (opt.)
Spindle bore	153 mm / 230 mm (opt.)	154 mm / 179-360 mm (opt.)
Taper of spindle bore	MT 7 / 1/20 (opt.)	-
Spindle speed	12 steps / 8-680 rpm	18 steps / 7-700 rpm Vari. speeds (opt.)
Taper of tailstock	MT 5	
Tailstock quill travel	250 mm	200 mm
Tailstock quill diameter	120 mm	115 mm
Main motor	20 HP / 30 HP (opt.)	20 HP / 25 / 30 / 40 / 50 HP (opt.)
Coolant pump motor	1/8 HP	
Machine size (L x W x H)	L : 3750 / 4250 / 5250 / 6250 / 7250 / 8250 / 9250 / 10250 mm W : 1740 mm	L : 3750 / 4250 / 5250 / 6250 / 7250 / 8250 / 9250 / 10250 / 11250 / 12250 / 13250 / 14250 mm W x H : 1800 x 1325 mm
Machine packing size (L x W x H)	L : 4000 / 4250 / 5310 / 6250 / 7500 / 8500 / 9500 / 10500 mm W x H : 1850 x 2080 mm	-
Net weight (approx.)	5700 / 6100 / 6800 / 7600 / 8400 / 9200 / 10000 / 10800 kgs	-
Gross weight (approx.)	5850 / 6250 / 6950 / 7750 / 8550 / 9350 / 10150 / 10950 kgs	-

\*Specifications are subject to change without prior notice.

#### BMT 3370X / BMT 3390X / BMT 33130X / BMT 33170X BMT 33210X / BMT 33250X / BMT 33290X / BMT 33330X

- |  |   |
|--|---|
| <ul style="list-style-type: none"> <li>■ STANDARD ACCESSORIES</li> <li>· One piece bed, floor type casting</li> <li>· 4-jaw chuck</li> <li>· 4-way rapid traverse</li> <li>· Back plate</li> <li>· Steady rest</li> <li>· Dead center &amp; center sleeve</li> <li>· Toolpost wrench</li> <li>· Anchor bolt</li> <li>· Coolant system</li> <li>· Work light</li> <li>· Tools &amp; tool box</li> </ul> | <ul style="list-style-type: none"> <li>■ OPTIONAL ACCESSORIES</li> <li>· 3-jaw chuck</li> <li>· Face plate</li> <li>· Follow rest</li> <li>· Taper turning attachment</li> <li>· Rear splash guard</li> <li>· Micrometer carriage stop</li> <li>· 4-position carriage stop</li> <li>· Quick change toolpost</li> <li>· Live center</li> <li>· Digital readout</li> <li>· CE standard</li> </ul> |
|--|---|

#### BMT 35PA

- |  |   |  |
|--|---|--|
| <ul style="list-style-type: none"> <li>■ STANDARD ACCESSORIES</li> <li>· One piece bed, floor type casting</li> <li>· Gear type headstock</li> <li>· 2-speed tailstock quill</li> <li>· 6-way rapid traverse</li> <li>· 4-way toolpost auto feed</li> <li>· One-shot lubrication system</li> <li>· Meter/inch community gear box</li> <li>· Electromagnetic brake</li> <li>· Carriage position device</li> <li>· Thread dial indicator</li> <li>· Dead center &amp; center sleeve</li> <li>· Follow type splash guard</li> <li>· Leadscrew cover</li> <li>· Water and oil collect plate under apron</li> <li>· Rear side chip and water collect plate</li> <li>· Coolant system</li> <li>· Halogen lamp</li> <li>· Tools &amp; tool box</li> </ul> | <ul style="list-style-type: none"> <li>■ OPTIONAL ACCESSORIES</li> <li>· 3-jaw &amp; 4-jaw chuck</li> <li>· Steady rest &amp; Follow rest</li> <li>· Enlarged spindle bore</li> <li>· Enlarged spindle motor</li> <li>· Enlarged tailstock quill</li> <li>· Roller supporter</li> <li>· Micrometer carriage stop</li> <li>· Boring bar tool holder</li> <li>· Rear chip conveyor</li> <li>· Tower turret</li> <li>· Compound toolpost</li> <li>· 2 axis toolpost</li> <li>· Quick change toolpost</li> <li>· Hydraulic turret (H6)</li> </ul> | <ul style="list-style-type: none"> <li>· Grinding attachment</li> <li>· Milling attachment</li> <li>· Taper turning attachment</li> <li>· Hydraulic copying attachment</li> <li>· Hydraulic taper and profile base</li> <li>· Hydraulic brake system</li> <li>· Semi-automatic cycle turning</li> <li>· Rear chuck adapter</li> <li>· Rear safety chuck guard</li> <li>· Front safety chuck guard</li> <li>· Digital readout</li> <li>· CE standard</li> </ul> |
|--|---|--|

# HEAVY DUTY CONVENTIONAL LATHE



24.SWING OVER BED 960 MM

▼ **BMT 3770X / BMT 3790X / BMT 37130X / BMT 37170X**  
**BMT 37210X / BMT 37250X / BMT 37290X / BMT 37330X**



▼ **BMT 3A38**



· Machines shown with optional accessories.

FOR BMT 3770X / BMT 3790X / BMT 37130X / BMT 37170X  
BMT 37210X / BMT 37250X / BMT 37290X / BMT 37330X :



▲ Chip Guard



▲ Steady Rest



▲ Follow Rest (Optional)

### SPECIFICATION:

Description	BMT 3A38	BMT 3770X / BMT 3790X / BMT 37130X / BMT 37170X BMT 37210X / BMT 37250X / BMT 37290X / BMT 37330X
Swing over bed	960 mm	
Swing over cross slide	650 mm	710 mm
Swing over gap	1510 mm	1260 mm
Center height	480 mm	
Distance between centers	1500 / 2000 / 3000 / 4000 / 5000 / 6000 / 7000 / 8000 / 9000 mm	1810 / 2310 / 3310 / 4310 / 5310 / 6310 / 7310 / 8310 mm
Bed width	560 mm	510 mm
Compound rest travel	300 mm	330 mm
Cross slide travel	540 mm	480 mm
Spindle nose	A2-11 / A2-15 / A2-20 (opt.)	A2-11 / A2-15 (opt.)
Spindle bore	156 mm / 230 / 260 / 310 / 360 mm (opt.)	153 mm / 230 mm (opt.)
Taper of spindle bore	MT 5 / MT 6 (opt.)	MT 7 / 1/20 (opt.)
Spindle speed	12 steps / 9~600 rpm	12 steps / 8~680 rpm
Taper of tailstock	MT 6	
Tailstock quill travel	300 mm	250 mm
Tailstock quill diameter	140 mm	120 mm
Main motor	25 HP / 30 HP (opt.)	20 HP / 30 HP (opt.)
Coolant pump motor	1/4 HP	1/8 HP
Machine size (L x W x H)	L : 3900 / 4400 / 5400 / 6400 / 7400 / 8400 / 9400 / 10400 / 11400 mm W x H : 1749 x 1970 mm	L : 3750 / 4250 / 5250 / 6250 / 7250 / 8250 / 9250 / 10250 mm W : 1740 mm
Machine packing size (L x W x H)	L : 4800 / 5300 / 6300 / 7300 / 8300 / 9300 / 10300 / 11300 / 12300 mm W x H : 2250 x 2150 mm	L : 4000 / 4250 / 5310 / 6250 / 7500 / 8500 / 9500 / 10500 mm W x H : 1850 x 2080 mm
Net weight (approx.)	7695 / 8220 / 8770 / 9320 / 10120 / 10920 / 11820 / 12720 / 13620 kgs	5700 / 6100 / 6800 / 7600 / 8400 / 9200 / 10000 / 10800 kgs
Gross weight (approx.)	8695 / 9220 / 9770 / 10320 / 11120 / 12420 / 13320 / 14220 / 15120 kgs	5850 / 6250 / 6950 / 7750 / 8550 / 9350 / 10150 / 10950 kgs

\*Specifications are subject to change without prior notice.

#### BMT 3A38

##### STANDARD ACCESSORIES

- X/Z axis rapid traverse
- Electromagnetic brake
- Auto lubrication system
- 4-way toolpost
- Meter/inch community gear box
- Guide way hardened, ground with wiper
- Tailstock center
- Leveling pads
- Coolant system
- Tools & tool box

##### OPTIONAL ACCESSORIES

- 3-jaw & 4-jaw chuck
- Face plate
- Steady rest & Follow rest
- 6-way rapid traverse
- Enlarged spindle bore
- Enlarged spindle motor
- Live center
- Quick change toolpost
- Taper turning attachment
- Hydraulic copying attachment
- Auto rapid threading device
- Boring attachment
- Grinding attachment
- Chuck guard
- Splash guard
- Toolpost guard
- Motorized tailstock
- Digital readout
- Work light
- CE & CSA standard

#### BMT 3770X / BMT 3790X / BMT 37130X / BMT 37170X BMT 37210X / BMT 37250X / BMT 37290X / BMT 37330X

##### STANDARD ACCESSORIES

- One piece bed, floor type casting
- 4-jaw chuck
- 4-way rapid traverse
- Back plate
- Steady rest
- Dead center & center sleeve
- Toolpost wrench
- Anchor bolt
- Coolant system
- Work light
- Tools & tool box

##### OPTIONAL ACCESSORIES

- 3-jaw chuck
- Face plate
- Follow rest
- Taper turning attachment
- Rear splash guard
- Micrometer carriage stop
- 4-position carriage stop
- Quick change toolpost
- Live center
- Digital readout
- CE standard

# HEAVY DUTY CONVENTIONAL LATHE



25.SWING OVER BED 1060 MM

▼ BMT 4170X / BMT 4190X / BMT 41130X / BMT 41170X  
BMT 41210X / BMT 41250X / BMT 41290X / BMT 41330X



▼ BMT 3A42



· Machines shown with optional accessories.

## OPTIONAL ACCESSORIES FOR BMT 3A42:



▲ Double Chuck



▲ 6-Way Rapid Traverse



▲ HD Steady Rest  
(2-point type)

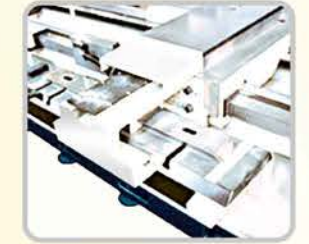

▲ Taper Attachment

## SPECIFICATION:

Description	BMT 4170X / BMT 4190X / BMT 41130X / BMT 41170X BMT 41210X / BMT 41250X / BMT 41290X / BMT 41330X	BMT 3A42
Swing over bed	1060 mm	
Swing over cross slide	810 mm	750 mm
Swing over gap	1360 mm	1610 mm
Center height	530 mm	
Distance between centers	1810 / 2310 / 3310 / 4310 / 5310 / 6310 / 7310 / 8310 mm	1500 / 2000 / 3000 / 4000 / 5000 / 6000 / 7000 / 8000 / 9000 mm
Bed width	510 mm	560 mm
Compound rest travel	330 mm	300 mm
Cross slide travel	480 mm	540 mm
Spindle nose	A2-11 / A2-15 (opt.)	A2-11 / A2-15 / A2-20 (opt.)
Spindle bore	153 mm / 230 mm (opt.)	156 mm / 230 / 260 / 310 / 360 mm (opt.)
Taper of spindle bore	MT 7 / 1/20 (opt.)	MT 5 / MT 6 (opt.)
Spindle speed	12 steps / 8~680 rpm	12 steps / 9~600 rpm
Taper of tailstock	MT 6	
Tailstock quill travel	250 mm	300 mm
Tailstock quill diameter	120 mm	140 mm
Main motor	20 HP / 30 HP (opt.)	25 HP / 30 HP (opt.)
Coolant pump motor	1/8 HP	1/4 HP
Machine packing size (L x W x H)	L : 3750 / 4250 / 5250 / 6250 / 7250 / 8250 / 9250 / 10250 mm W : 1740 mm	L : 3900 / 4400 / 5400 / 6400 / 7400 / 8400 / 9400 / 10400 / 11400 mm W x H : 1749 x 2020 mm
Machine size (L x W x H)	L: 4000 / 4250 / 5310 / 6250 / 7500 / 8500 / 9500 / 10500 mm W x H : 1850 x 2080 mm	L : 4800 / 5300 / 6300 / 7300 / 8300 / 9300 / 10300 / 11300 / 12300 mm W x H : 2250 x 2250 mm
Net weight (approx.)	5700 / 6100 / 6800 / 7600 / 8400 / 9200 / 10000 / 10800 kgs	8555 / 9080 / 9630 / 10180 / 10980 / 11780 / 12680 / 13580 / 14480 kgs
Gross weight (approx.)	5850 / 6250 / 6950 / 7750 / 8550 / 9350 / 10150 / 10950 kgs	9555 / 10080 / 10630 / 11180 / 11980 / 13280 / 14180 / 15080 / 15980 kgs

\*Specifications are subject to change without prior notice.

### BMT 4170X / BMT 4190X / BMT 41130X / BMT 41170X BMT 41210X / BMT 41250X / BMT 41290X / BMT 41330X

#### ■ STANDARD ACCESSORIES

- One piece bed, floor type casting
- 4-jaw chuck
- 4-way rapid traverse
- Back plate
- Steady rest
- Dead center & center sleeve
- Toolpost wrench
- Anchor bolt
- Coolant system
- Work light
- Tools & tool box

#### ■ OPTIONAL ACCESSORIES

- 3-jaw chuck
- Face plate
- Follow rest
- Taper turning attachment
- Rear splash guard
- Micrometer carriage stop
- 4-position carriage stop
- Quick change toolpost
- Live center
- Digital readout
- CE standard

### BMT 3A42

#### ■ STANDARD ACCESSORIES

- X/Z axis rapid traverse
- Electromagnetic brake
- Auto lubrication system
- 4-way toolpost
- Meter/inch community gear box
- Guide way hardened, ground with wiper
- Tailstock center
- Leveling pads
- Coolant system
- Tools & tool box

#### ■ OPTIONAL ACCESSORIES

- 3-jaw & 4-jaw chuck
- Face plate
- Steady rest & Follow rest
- 6-way rapid traverse
- Enlarged spindle bore
- Enlarged spindle motor
- Live center
- Quick change toolpost
- Taper turning attachment
- Hydraulic copying attachment
- Auto rapid threading device
- Boring attachment
- Grinding attachment
- Chuck guard
- Splash guard
- Toolpost guard
- Motorized tailstock
- Digital readout
- Work light
- CE & CSA standard

# HEAVY DUTY CONVENTIONAL LATHE



26.SWING OVER BED 1010 MM & 1135 MM

▼ **BMT 40PA / BMT 45PA**



· Machines shown with optional accessories.

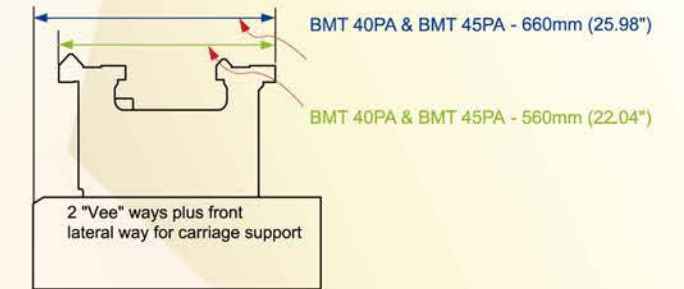

**OPTIONAL ACCESSORIES:**



▲ Tower Turret Turret square : 205mm (8.07")



▲ Compound Tool Post (Power Feed) Travel: 450mm (17.72")



▲ 2-axes Tool Post



▲ Hydraulic Turret (H6)



▲ 3-Jaw Scroll Chuck (Back Plate Type)



▲ 3-Jaw Scroll Chuck (Direct Mount)



▲ 4-Jaw Independent Chuck Steel Body Type



▲ 4-Jaw Independent Chuck Semi-Steel Body Type



▲ 4-Jaw Independent Chuck Face Plate Type

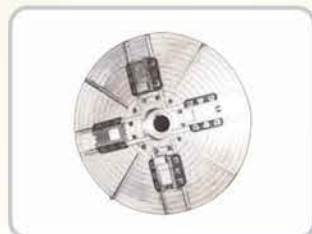

▲ 4-Jaw Independent Chuck Top Jaw Type

**SPECIFICATION:**

Description	BMT 40PA	BMT 45PA
Swing over bed	1010 mm	1135 mm
Swing over cross slide	745 mm	875 mm
Center height	510 mm	575 mm
Distance between centers	1500 / 2000 / 3000 / 4000 / 5000 / 6000 / 7000 / 8000 / 9000 / 10000 / 11000 / 12000 mm	
Bed width	560 mm	
Compound rest travel	450 mm	
Cross slide travel	670 mm	
Spindle nose	A2-11 / A2-15 / A2-20 (opt.)	A2-11 / A2-15-A2-28 (opt.)
Spindle bore	154 mm / 179-360 mm (opt.)	154 mm / 179-470 mm (opt.)
Spindle speed	18 steps / 7-700 rpm	
Taper of tailstock	MT 6	
Tailstock quill travel	200 mm	
Tailstock quill diameter	115 mm	
Main motor	20 HP / 25 / 30 / 40 / 50 HP (opt.)	
Coolant pump motor	1/8 HP	
Machine size (L x W x H)	L : 3750 / 4250 / 5250 / 6250 / 7250 / 8250 / 9250 / 10250 / 11250 / 12250 / 13250 / 14250 mm W x H : 1800 x 1325 mm	

\*Specifications are subject to change without prior notice.

**BMT 40PA / BMT 45PA**

■ **STANDARD ACCESSORIES**

- One piece bed, floor type casting
- Gear type headstock
- 2-speed tailstock quill
- 6-way rapid traverse
- 4-way toolpost auto feed
- One-shot lubrication system
- Meter/inch community gear box
- Electromagnetic brake
- Carriage position device
- Thread dial indicator
- Dead center & center sleeve
- Follow type splash guard
- Leadscrew cover
- Water and oil collect plate under apron
- Rear side chip and water collect plate
- Coolant system
- Halogen lamp
- Tools & tool box

■ **OPTIONAL ACCESSORIES**

- 3-jaw & 4-jaw chuck
- Steady rest & Follow rest
- Enlarged spindle bore
- Enlarged spindle motor
- Enlarged tailstock quill
- Roller support
- Micrometer carriage stop
- Boring bar tool holder
- Rear chip conveyor
- Tower turret
- Compound toolpost
- 2 axis toolpost
- Quick change toolpost
- Hydraulic turret (H6)
- Grinding attachment
- Milling attachment
- Taper turning attachment
- Hydraulic copying attachment
- Hydraulic taper and profile base
- Hydraulic brake system
- Semi-automatic cycle turning
- Rear chuck adapter
- Rear safety chuck guard
- Front safety chuck guard
- Digital readout
- CE standard

# HEAVY DUTY CONVENTIONAL LATHE



27.SWING OVER BED 1165 MM ~ 1200 MM

## ▼ BMT 45PB

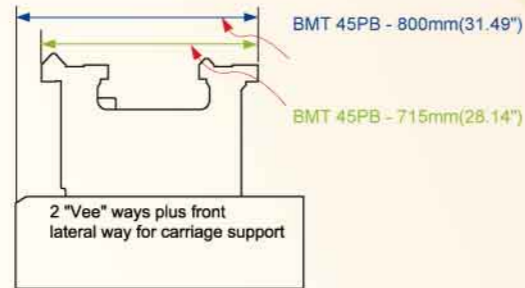

## SPECIFICATION:

Description	BMT 45PB	BMT 3A46	BMT 3A47
Swing over bed	1165 mm	1170 mm	1200 mm
Swing over cross slide	840 mm	860 mm	830 mm
Swing over gap	-	1720 mm	1750 mm
Center height	590 mm	585 mm	600 mm
Distance between centers	1500 / 2000 / 3000 / 4000 / 5000 / 6000 / 7000 / 8000 / 9000 / 10000 / 11000 / 12000 mm	1500 / 2000 / 3000 / 4000 / 5000 / 6000 / 7000 / 8000 / 9000 mm	2000 / 3000 / 4000 / 5000 / 6000 / 7000 / 8000 / 9000 mm
Bed width	715 mm	560 mm	800 mm
Compound rest travel	500 mm	300 mm	350 mm
Cross slide travel	800 mm	540 mm	760 mm
Spindle nose	A2-11 / A2-15~A2-28 (opt.)	A2-11 / A2-15 / A2-20 (opt.)	A2-15 / A2-20 / A2-28 (opt.)
Spindle bore	154 mm / 179~470 mm (opt.)	156 mm / 230 / 260 / 310 / 360 mm (opt.)	230 mm / 260 / 310 / 360 / 535 mm (opt.)
Taper of spindle bore	-	MT 5 / MT 6 (opt.)	MT 6
Spindle speed	18 steps / 7~700 rpm	12 steps / 9~600 rpm	12 steps / 6~400 rpm
Taper of tailstock	MT 6		MT 7
Tailstock quill travel	200 mm	300 mm	
Tailstock quill diameter	145 mm	140 mm	200 mm / 290 mm (opt.)
Main motor	30 HP / 40 / 50 HP (opt.)	25 HP / 30 HP (opt.)	30 HP / 40 / 50 HP (opt.)
Coolant pump motor	1/8 HP	1/4 HP	
Machine size (L x W x H)	L : 4050 / 4550 / 5550 / 6550 / 7550 / 8550 / 9550 / 10550 / 11550 / 12550 / 13550 / 14550 mm W x H : 1990 x 1455 mm	L : 3900 / 4400 / 5400 / 6400 / 7400 / 8400 / 9400 / 10400 / 11400 mm W x H : 1749 x 2090 mm	L : 4649 / 5649 / 6649 / 7649 / 8649 / 9649 / 10649 / 11649 mm W x H : 2206 x 2415 mm
Machine packing size (L x W x H)	-	L : 4800 / 5300 / 6300 / 7300 / 8300 / 9300 / 10300 / 11300 / 12300 mm W x H : 2250 x 2350 mm	L : 5300 / 6300 / 7300 / 8300 / 9300 / 10300 / 11300 / 12300 mm W x H : 2250 x 2150 mm
Net weight (approx.)	-	8705 / 9230 / 9780 / 10330 / 11130 / 11930 / 12830 / 13730 / 14630 kgs	13750 / 15450 / 17600 / 19900 / 22200 / 24550 / 27000 / 29600 kgs
Gross weight (approx.)	-	9705 / 10230 / 10780 / 11330 / 12130 / 13430 / 14330 / 15230 / 16130 kgs	14750 / 16450 / 18600 / 20900 / 23700 / 26050 / 28500 / 31100 kgs

\*Specifications are subject to change without prior notice.

## ▼ BMT 3A46 / BMT 3A47

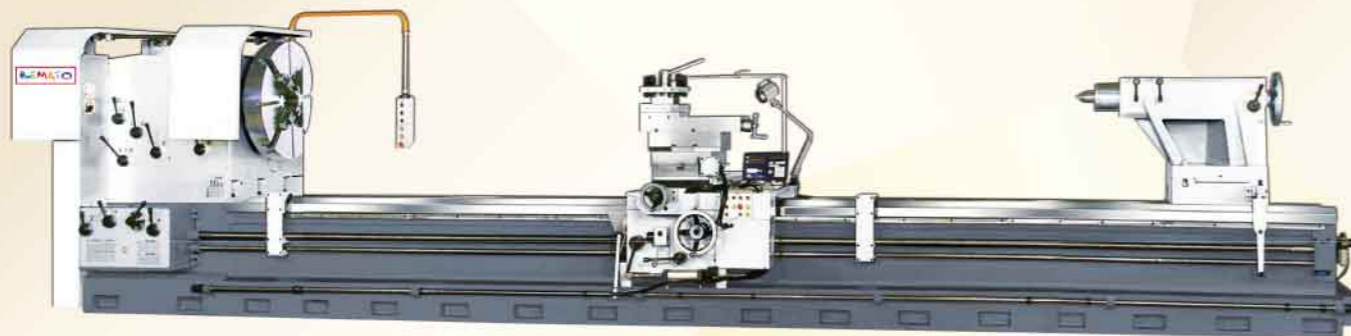

· Machines shown with optional accessories.

### BMT 45PB

#### ■ STANDARD ACCESSORIES

- One piece bed, floor type casting
- Gear type headstock
- 2-speed tailstock quill
- 6-way rapid traverse
- 4-way toolpost auto feed
- One-shot lubrication system
- Meter/inch community gear box
- Electromagnetic brake
- Carriage position device
- Thread dial indicator
- Dead center & center sleeve
- Follow type splash guard
- Leadscrew cover
- Water and oil collect plate under apron
- Rear side chip and water collect plate
- Coolant system
- Halogen lamp
- Tools & tool box

#### ■ OPTIONAL ACCESSORIES

- 3-jaw & 4-jaw chuck
- Steady rest & Follow rest
- Enlarged spindle bore
- Enlarged spindle motor
- Enlarged tailstock quill
- Roller support
- Micrometer carriage stop
- Boring bar tool holder
- Rear chip conveyor
- Tower turret
- Compound toolpost
- 2 axis toolpost
- Quick change toolpost
- Hydraulic turret (H6)
- Grinding attachment
- Milling attachment
- Taper turning attachment
- Hydraulic copying attachment
- Hydraulic taper and profile base
- Hydraulic brake system
- Semi-automatic cycle turning
- Rear chuck adapter
- Rear safety chuck guard
- Front safety chuck guard
- Digital readout
- CE standard

### BMT 3A46 / BMT 3A47

#### ■ STANDARD ACCESSORIES

- X/Z axis rapid traverse
- Main motor
- Electromagnetic brake
- Auto lubrication system
- 4-way toolpost
- Meter/inch community gear box
- Guide way hardened, ground with wiper
- Tailstock center
- Leveling pads
- Coolant system
- Tools & tool box

#### ■ OPTIONAL ACCESSORIES

- 3-jaw & 4-jaw chuck
- Face plate
- Steady rest & Follow rest
- 6-way rapid traverse
- Enlarged spindle bore
- Enlarged spindle motor
- Yaskawa inverter for BMT 3A47
- Live center
- Quick change toolpost
- Taper turning attachment
- Hydraulic copying attachment
- Auto rapid threading device
- Boring attachment
- Grinding attachment
- Chuck guard & Splash guard
- Toolpost guard
- Motorized tailstock
- Digital readout
- Work light
- CE & CSA standard

# HEAVY DUTY CONVENTIONAL LATHE



28.SWING OVER BED 1275 MM & 1280 MM

## ▼ BMT 50PA



## ▼ BMT 50PB



· Machines shown with optional accessories.

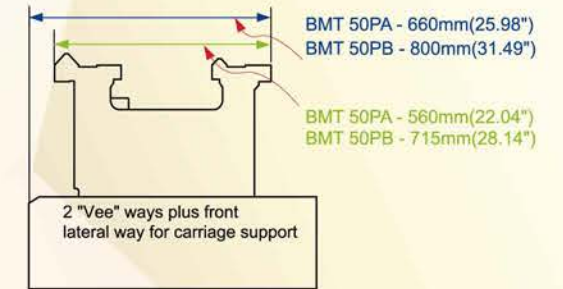

### SPECIFICATION:

Description	BMT 50PA	BMT 50PB
Swing over bed	1275 mm	1280 mm
Swing over cross slide	1015 mm	950 mm
Center height	645 mm	650 mm
Distance between centers	1500 / 2000 / 3000 / 4000 / 5000 / 6000 / 7000 / 8000 / 9000 / 10000 / 11000 / 12000 mm	
Bed width	560 mm	715 mm
Compound rest travel	450 mm	500 mm
Cross slide travel	670 mm	800 mm
Spindle nose	A2-11 / A2-15~A2-32 (opt.)	A2-11 / A2-15~A2-32 (opt.)
Spindle bore	154 mm / 179~565 mm (opt.)	154 mm / 179~610 mm (opt.)
Spindle speed	18 steps / 7~700 rpm	
Taper of tailstock	MT 6	
Tailstock quill travel	200 mm	
Tailstock quill diameter	115 mm	145 mm
Main motor	20 HP / 25 / 30 / 40 / 50 HP (opt.)	30 HP / 40 / 50 HP (opt.)
Coolant pump motor	1/8 HP	
Machine size (L x W x H)	L : 3750 / 4250 / 5250 / 6250 / 7250 / 8250 / 9250 / 10250 / 11250 / 12250 / 13250 / 14250 mm W x H : 1800 x 1325 mm	L : 4050 / 4550 / 5550 / 6550 / 7550 / 8550 / 9550 / 10550 / 11550 / 12550 / 13550 / 14550 mm W x H : 1990 x 1455 mm

\*Specifications are subject to change without prior notice.

### BMT 50PA / BMT 50PB

#### ■ STANDARD ACCESSORIES

- One piece bed, floor type casting
- Gear type headstock
- 2 shear bed way with extra way
- 6-way rapid traverse
- 4-way toolpost auto feed
- One-shot lubrication system
- Meter/inch community gear box
- Electromagnetic brake
- Carriage position device
- Thread dial indicator
- Dead center & center sleeve
- Follow type splash guard
- Leadscrew cover
- Water and oil collect plate under apron
- Rear side chip and water collect plate
- Coolant system
- Halogen lamp
- Tools & tool box

#### ■ OPTIONAL ACCESSORIES

- 3-jaw & 4-jaw chuck
- Steady rest & Follow rest
- Enlarged spindle bore
- Enlarged spindle motor
- Enlarged tailstock quill
- Roller supporter
- Micrometer carriage stop
- Boring bar tool holder
- Rear chip conveyor
- Tower turret
- Compound toolpost
- 2 axis toolpost
- Quick change toolpost
- Hydraulic turret (H6)
- Grinding attachment
- Milling attachment
- Taper turning attachment
- Hydraulic copying attachment
- Hydraulic taper and profile base
- Hydraulic brake system
- Semi-automatic cycle turning
- Rear chuck adapter
- Rear safety chuck guard
- Front safety chuck guard
- Digital readout
- CE standard

# HEAVY DUTY CONVENTIONAL LATHE



## 29.SWING OVER BED 1300 MM & 1400 MM

### ▼ BMT 50PH

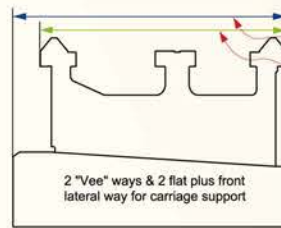
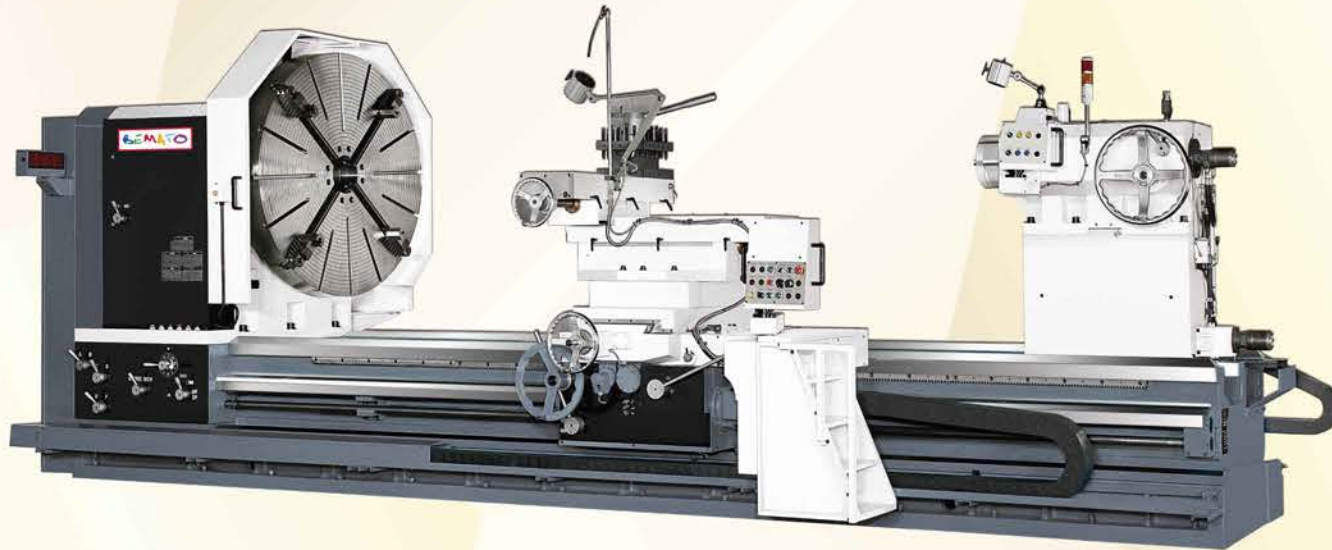

BMT 50PH - 1270mm(50.00")  
BMT 50PH - 1100mm(43.30")

### ▼ BMT 3A55

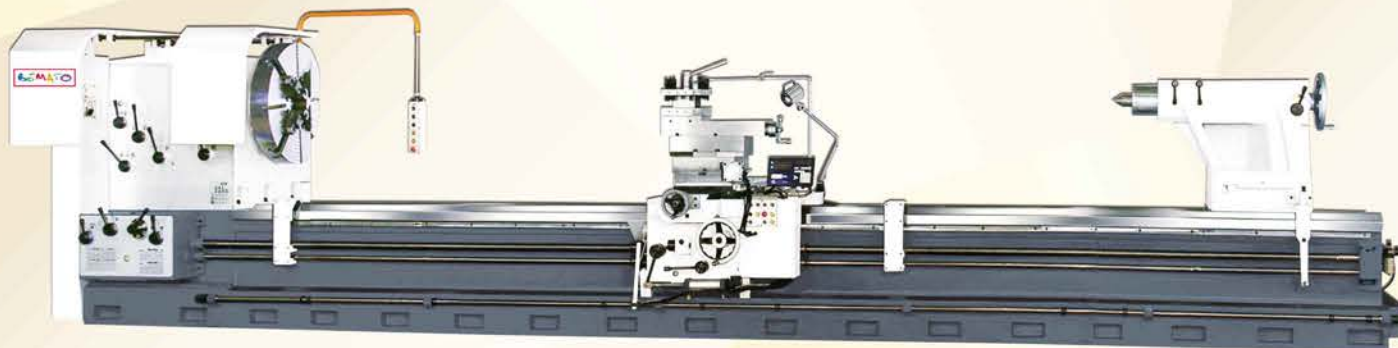

· Machines shown with optional accessories.

### SPECIFICATION:

Description	BMT 50PH	BMT 3A55
Swing over bed	1300 mm	1400 mm
Swing over cross slide (short carriage)	985 mm	1030 mm
Swing over cross slide (Long carriage)	785 mm	-
Swing over gap	-	1950 mm
Center height	650 mm	700 mm
Distance between centers	3000 / 4000 / 5000 / 6000 / 7000 / 8000 / 9000 / 10000 / 11000 / 12000 mm	2000 / 3000 / 4000 / 5000 / 6000 / 7000 / 8000 / 9000 mm
Bed width	1100 mm	800 mm
Compound rest travel	600 mm	350 mm
Cross slide travel	Short carriage : 415 mm / Long carriage : 1170 mm	760 mm
Spindle nose	A2-15 / A2-20-A2-32 (opt.)	A2-15 / A2-20 / A2-28 (opt.)
Spindle bore	179 mm / 205-610 mm (opt.)	230 mm / 260 / 310 / 360 / 535 mm (opt.)
Taper of spindle bore	-	MT 6
Spindle speed	18 steps / 7-535 rpm	12 steps / 6-400 rpm
Taper of tailstock	MT 6	MT 7
Tailstock quill travel	200 mm	300 mm
Tailstock quill diameter	235 mm	200 mm / 290 mm (opt.)
Main motor	40 HP / 50 / 60 / 75 / 100 HP (opt.)	30 HP / 40 / 50 HP (opt.)
Coolant pump motor	1/2 HP	1/4 HP
Machine size (L x W x H)	L : 6370 / 7370 / 8370 / 9370 / 10370 / 11370 / 12370 / 13370 / 14370 / 15370 mm W x H : 2660 x 1820 mm	L : 4649 / 5649 / 6649 / 7649 / 8649 / 9649 / 10649 / 11649 mm W x H : 2206 x 2315 mm
Machine packing size (L x W x H)	-	L : 5300 / 6300 / 7300 / 8300 / 9300 / 10300 / 11300 / 12300 mm W x H : 2250 x 2250 mm
Net weight (approx.)	-	14650 / 16550 / 18700 / 21000 / 23300 / 25650 / 28000 / 30700 kgs
Gross weight (approx.)	-	15650 / 17550 / 19700 / 22000 / 24800 / 27150 / 29500 / 32200 kgs

\*Specifications are subject to change without prior notice.

#### BMT 50PH

##### ■ STANDARD ACCESSORIES

- One piece bed, floor type casting
- 4 shear bed with dual way center guide & front lateral way
- 2-speed tailstock quill
- 6-way rapid traverse
- One-shot lubrication system
- Meter/inch community gear box
- Electromagnetic brake
- Carriage position device
- Thread dial indicator
- Dead center & center sleeve
- Follow type splash guard
- Leadscrew cover
- Water and oil collect plate under apron
- Rear side chip and water collect plate
- Coolant system
- Halogen lamp
- Tools & tool box

##### ■ OPTIONAL ACCESSORIES

- 3-jaw & 4-jaw chuck
- Steady rest & Follow rest
- Roller support
- Micrometer carriage stop
- Boring bar tool holder
- Rear chip conveyor
- Tower turret
- Compound toolpost
- 2 axis toolpost
- Quick change toolpost
- Hydraulic turret (H6)
- Taper turning attachment
- Hydraulic copying attachment
- Hydraulic taper and profile base
- Semi-automatic cycle turning
- Rear adapter
- Rear safety chuck guard
- Front safety chuck guard
- Digital readout
- CE standard

#### BMT 3A55

##### ■ STANDARD ACCESSORIES

- X/Z axis rapid traverse
- Main motor
- Electromagnetic brake
- Auto lubrication system
- 4-way toolpost
- Meter/inch community gear box
- Guide way hardened, ground with wiper
- Tailstock center
- Leveling pads
- Coolant system
- Tools & tool box

##### ■ OPTIONAL ACCESSORIES

- 3-jaw & 4-jaw chuck
- Face plate
- Steady rest & Follow rest
- 6-way rapid traverse
- Enlarged spindle bore
- Enlarged spindle motor
- Live center
- Quick change toolpost
- Taper turning attachment
- Hydraulic copying attachment
- Auto rapid threading device
- Boring attachment
- Grinding attachment
- Chuck guard & Splash guard
- Toolpost guard
- Motorized tailstock
- Digital readout
- Work light
- CE & CSA standard



# HEAVY DUTY CONVENTIONAL LATHE



## 30.SWING OVER BED 1530 MM ~ 1600 MM

### ▼ BMT 60PB



### ▼ BMT 60PC



### ▼ BMT 60PH

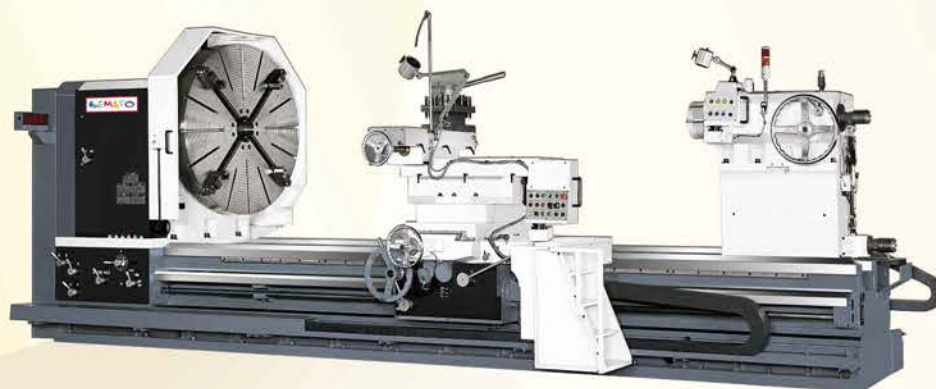

### ▼ BMT 3A63

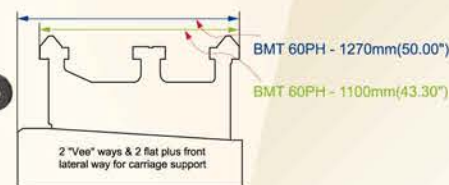
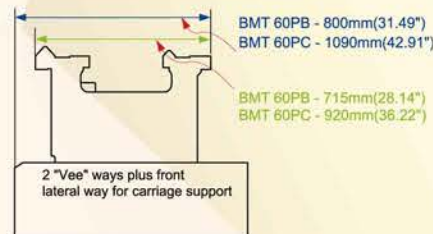
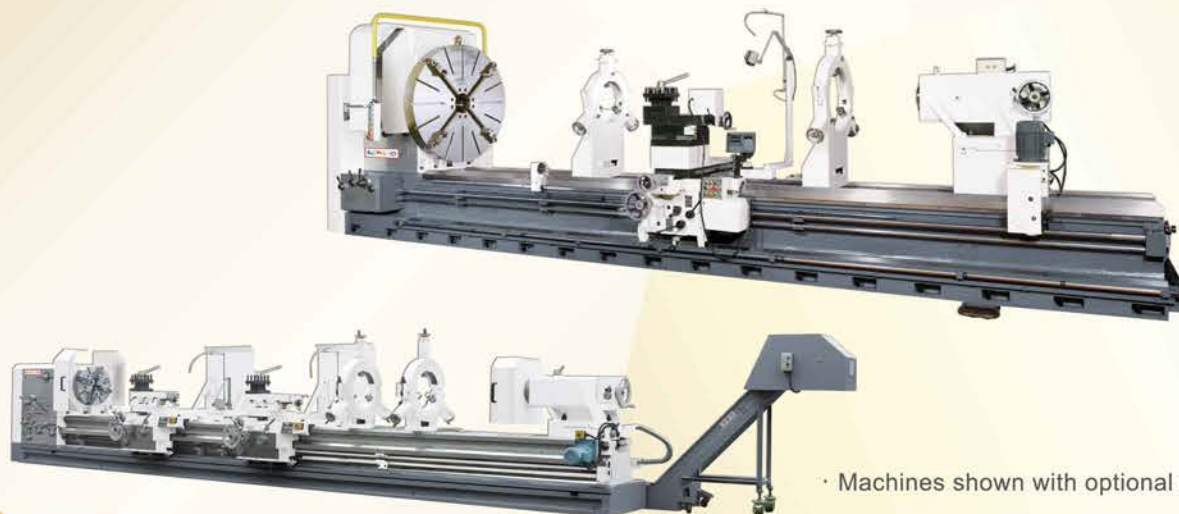

Machines shown with optional accessories.

### SPECIFICATION:

Description	BMT 60PB	BMT 60PC	BMT 60PH	BMT 3A63
Swing over bed	1530 mm	1560 mm	1550 mm	1600 mm
Swing over cross slide (short carriage)	1210 mm	1100 mm	1225 mm	1230 mm
Swing over cross slide (Long carriage)	-	-	1035 mm	-
Center height	775 mm	805 mm	775 mm	800 mm
Distance between centers	1500 / 2000 / 3000 / 4000 / 5000 / 6000 / 7000 / 8000 / 9000 / 10000 / 11000 / 12000 mm	1500 / 2000 / 3000 / 4000 / 5000 / 6000 / 7000 / 8000 / 9000 / 10000 / 11000 / 12000 mm	3000 / 4000 / 5000 / 6000 / 7000 / 8000 / 9000 / 10000 / 11000 / 12000 mm	2000 / 3000 / 4000 / 5000 / 6000 / 7000 / 8000 / 9000 mm
Bed width	715 mm	920 mm	1100 mm	800 mm
Compound rest travel	500 mm	600 mm		350 mm
Cross slide travel	800 mm	1170 mm	Short carriage : 415 mm / Long carriage : 1170 mm	760 mm
Spindle nose	A2-15 / A2-20~A2-40 (opt.)			A2-15 / A2-20 / A2-28 (opt.)
Spindle bore	179 mm / 205~765 mm (opt.)			230 mm / 260 / 310 / 360 / 535 mm (opt.)
Taper of spindle bore	-			MT 6
Spindle speed	18 steps / 7~535 rpm			12 steps / 6~400 rpm
Taper of tailstock	MT 6			MT 7
Tailstock quill travel	200 mm			300 mm
Tailstock quill diameter	145 mm	160 mm	235 mm	200 mm / 290 mm (opt.)
Main motor	30 HP / 40 / 50 HP (opt.)	30 HP / 40 / 50 / 60 / 75 HP (opt.)	40 HP / 50 / 60 / 75 / 100 HP (opt.)	30 HP / 40 / 50 HP (opt.)
Coolant pump motor	1/8 HP	1/8 HP	1/2 HP	1/4 HP
Machine size (L x W x H)	L : 4050 / 4550 / 5550 / 6550 / 7550 / 8550 / 9550 / 10550 / 11550 / 12550 / 13550 / 14550 mm W x H : 1990 x 1455 mm	L : 4390 / 4890 / 5890 / 6890 / 7890 / 8890 / 9890 / 10890 / 11890 / 12890 / 13890 / 14890 mm W x H : 2090 x 1730 mm	L : 6370 / 7370 / 8370 / 9370 / 10370 / 11370 / 12370 / 13370 / 14370 / 15370 mm W x H : 2660 x 1820 mm	L : 4870 / 5870 / 6870 / 7870 / 8870 / 9870 / 10870 / 11870 / 12870 mm W x H : 1850 x 2150 mm
Machine packing size (L x W x H)	-			L : 5300 / 6300 / 7300 / 8300 / 9300 / 10300 / 11300 / 12300 mm W x H : 2250 x 2350 mm
Net weight (approx.)	-			15550 / 17250 / 19400 / 21700 / 24000 / 26350 / 28700 / 31400 kgs
Gross weight (approx.)	-			16550 / 18250 / 20400 / 22700 / 25500 / 27850 / 30200 / 32900 kgs

\*Specifications are subject to change without prior notice.

BMT 60PB		BMT 60PC / BMT 60PH		BMT 3A63	
<b>STANDARD ACCESSORIES</b> <ul style="list-style-type: none"> <li>One piece bed, floor type casting</li> <li>Gear type headstock</li> <li>2-speed tailstock quill</li> <li>6-way rapid traverse</li> <li>4-way toolpost auto feed</li> <li>One-shot lubrication system</li> <li>Meter/inch community gear box</li> <li>Electromagnetic brake</li> <li>Carriage position device</li> <li>Thread dial indicator</li> <li>Dead center &amp; center sleeve</li> <li>Follow type splash guard</li> <li>Leadscrew cover</li> <li>Water and oil collect plate under apron</li> <li>Rear side chip and water collect plate</li> <li>Coolant system</li> <li>Halogen lamp</li> <li>Tools &amp; tool box</li> </ul>	<b>OPTIONAL ACCESSORIES</b> <ul style="list-style-type: none"> <li>3-jaw &amp; 4-jaw chuck</li> <li>Steady rest &amp; Follow rest</li> <li>Enlarged spindle bore</li> <li>Enlarged spindle motor</li> <li>Enlarged tailstock quill</li> <li>Roller supporter</li> <li>Micrometer carriage stop</li> <li>Boring bar tool holder</li> <li>Rear chip conveyor</li> <li>Tower turret</li> <li>Compound toolpost</li> <li>2 axis toolpost</li> <li>Quick change toolpost</li> <li>Hydraulic turret (H6)</li> <li>Grinding attachment</li> <li>Milling attachment</li> <li>Taper turning attachment</li> <li>Hydraulic copying attachment</li> <li>Hydraulic taper and profile base</li> <li>Hydraulic brake system</li> <li>Semi-automatic cycle turning</li> <li>Rear chuck adapter</li> <li>Rear safety chuck guard</li> <li>Front safety chuck guard</li> <li>Digital readout</li> <li>CE standard</li> </ul>	<b>STANDARD ACCESSORIES</b> <ul style="list-style-type: none"> <li>One piece bed, floor type casting</li> <li>4 shear bed with dual way center guide &amp; front lateral way for BMT 60PH</li> <li>2 shear bed with extra way for BMT 60PC</li> <li>Variable spindle speed through pneumatic shifting for BMT 60PH</li> <li>Gear type headstock for BMT 60PC</li> <li>2-speed tailstock quill</li> <li>6-way rapid traverse</li> <li>One-shot lubrication system</li> <li>Meter/inch community gear box</li> <li>Electromagnetic brake</li> <li>Carriage position device</li> <li>Thread dial indicator</li> <li>Dead center &amp; center sleeve</li> <li>Follow type splash guard</li> <li>Leadscrew cover</li> <li>Water and oil collect plate under apron</li> <li>Rear side chip and water collect plate</li> <li>Coolant system</li> <li>Halogen lamp</li> <li>Tools &amp; tool box</li> </ul>	<b>OPTIONAL ACCESSORIES</b> <ul style="list-style-type: none"> <li>3-jaw &amp; 4-jaw chuck</li> <li>Steady rest &amp; Follow rest</li> <li>Roller support</li> <li>Micrometer carriage stop</li> <li>Boring bar tool holder</li> <li>Rear chip conveyor</li> <li>Tower turret</li> <li>Compound toolpost</li> <li>2 axis toolpost</li> <li>Quick change toolpost</li> <li>Hydraulic turret (H6)</li> <li>Taper turning attachment</li> <li>Hydraulic copying attachment</li> <li>Hydraulic taper and profile base</li> <li>Semi-automatic cycle turning</li> <li>Rear adapter</li> <li>Rear safety chuck guard</li> <li>Front safety chuck guard</li> <li>Digital readout</li> <li>CE standard</li> </ul>	<b>STANDARD ACCESSORIES</b> <ul style="list-style-type: none"> <li>X/Z axis rapid traverse</li> <li>Main motor</li> <li>Electromagnetic brake</li> <li>Auto lubrication system</li> <li>4-way toolpost</li> <li>Meter/inch community gear box</li> <li>Guide way hardened, ground with wiper</li> <li>Tailstock center</li> <li>Leveling pads</li> <li>Coolant system</li> <li>Tools &amp; tool box</li> </ul>	<b>OPTIONAL ACCESSORIES</b> <ul style="list-style-type: none"> <li>3-jaw &amp; 4-jaw chuck</li> <li>Face plate</li> <li>Steady rest &amp; Follow rest</li> <li>6-way rapid traverse</li> <li>Enlarged spindle bore</li> <li>Enlarged spindle motor</li> <li>Yaskawa inverter</li> <li>Live center</li> <li>Quick change toolpost</li> <li>Taper turning attachment</li> <li>Hydraulic copying attachment</li> <li>Auto rapid threading device</li> <li>Boring attachment</li> <li>Grinding attachment</li> <li>Chuck guard</li> <li>Splash guard</li> <li>Toolpost guard</li> <li>Motorized tailstock</li> <li>Digital readout</li> <li>Work light</li> <li>CE &amp; CSA standard</li> </ul>

# HEAVY DUTY CONVENTIONAL LATHE



## 31.SWING OVER BED 1800 MM & 1805 MM

### ▼ BMT 3A70



### ▼ BMT 70PH

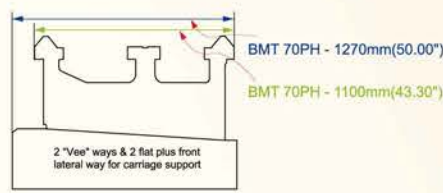
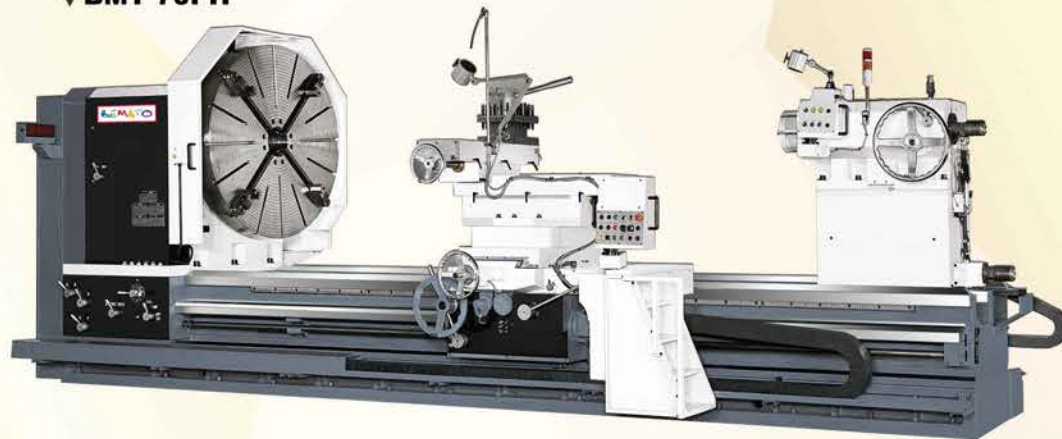

### ▼ BMT 70PC

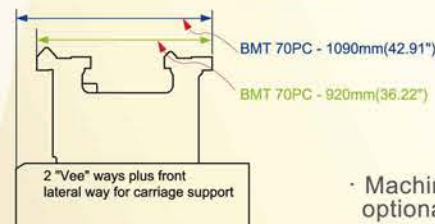

Machines shown with optional accessories.

### SPECIFICATION:

Description	BMT 3A70	BMT 70PH	BMT 70PC
Swing over bed	1800 mm		1805 mm
Swing over cross slide (short carriage)	1350 mm	1470 mm	1350 mm
Swing over cross slide (Long carriage)	-	1285 mm	-
Center height	900 mm		930 mm
Distance between centers (DBC)	3000 / 4000 / 5000 / 6000 / 7000 / 8000 / 9000 / 10000 / 11000 / 12000 mm		1500 / 2000 / 3000 / 4000 / 5000 / 6000 / 7000 / 8000 / 9000 / 10000 / 11000 / 12000 mm
Bed width	1345 mm	1100 mm	920 mm
Compound rest trave	X1: 250 mm / Z1: 400 mm (auto feeding)	600 mm	
Cross slide travel	1250 mm	Short carriage : 415 mm / Long : 1170 mm	1170 mm
Spindle nose	A2-15 / A2-20 (opt.)	A2-15 / A2-20~A2-40 (opt.)	
Spindle bore	210 mm	235 mm / 255~815 mm (opt.)	
Taper of spindle bore	MT 6	-	
Spindle speed	4 steps / 5~460 rpm	18 steps / 6~480 rpm	
Taper of tailstock	MT 7	MT 6	
Tailstock quill travel	300 mm	200 mm	
Tailstock quill diameter	290 mm / 350 mm (opt.)	235 mm	160 mm
Main motor	75 HP / 100 HP (opt.)	40 HP / 50 / 60 / 75 / 100 HP (opt.)	30 HP / 40 / 50 / 60 / 75 HP (opt.)
Coolant pump motor	1 HP	1/2 HP	1/8 HP
Machine size (L x W x H)	L : 7627 / 8627 / 9627 / 10627 / 11627 / 12627 / 13627 / 14627 / 15627 / 16627 mm W x H : 3237 x 3967 mm	L : 6370 / 7370 / 8370 / 9370 / 10370 / 11370 / 12370 / 13370 / 14370 / 15370 mm W x H : 2660 x 1820 mm	L : 4390 / 4890 / 5890 / 6890 / 7890 / 8890 / 9890 / 10890 / 11890 / 12890 / 13890 / 14890 mm W x H : 2090 x 1730 mm
Machine packing size (Container type)	DBC 3m , 4m : one 40' HQ + one 40' GP DBC 5m, 6m : one 40' HQ + two 40' GP DBC 7m, 8m, 9m : one 40' FR/HQ + two 40' HQ DBC 10m, 11m, 12m : four 40' HQ	-	
Net weight (approx.)	30 / 33.5 / 37 / 40.5 / 44 / 47.5 / 51 / 54.5 / 58 / 61.5 tons	-	
Gross weight (approx.)	31.5 / 35 / 38.5 / 42.5 / 46 / 49.5 / 53 / 56.5 / 60 / 63.5 tons	-	

\*Specifications are subject to change without prior notice.

BMT 3A70	
<b>STANDARD ACCESSORIES</b> <ul style="list-style-type: none"> <li>4-way toolpost</li> <li>6-way rapid traverse</li> <li>Main motor with inverter</li> <li>Auto lubrication system</li> <li>Hydraulic spindle disk brake</li> <li>Metric/inch community gear box</li> <li>Tailstock dead center</li> <li>Tailstock rotary quill</li> <li>Motorized tailstock</li> <li>Leveling pads</li> <li>Coolant system</li> <li>Tools &amp; tool box</li> </ul>	<b>OPTIONAL ACCESSORIES</b> <ul style="list-style-type: none"> <li>3-jaw &amp; 4-jaw chuck</li> <li>Face plate</li> <li>Steady rest &amp; Follow rest</li> <li>Boring attachment</li> <li>Grinding attachment</li> <li>Chuck guard</li> <li>Splash guard</li> <li>Digital readout</li> <li>Work light</li> <li>CE &amp; CSA standard</li> </ul>

BMT 70PH / BMT 70PC	
<b>STANDARD ACCESSORIES</b> <ul style="list-style-type: none"> <li>One piece bed, floor type casting</li> <li>4 shear bed with dual way center guide &amp; front lateral way for BMT 70PH</li> <li>2 shear bed with extra way for BMT 70PC</li> <li>Variable spindle speed through pneumatic shifting for BMT 70PH</li> <li>Gear type headstock for BMT 70PC</li> <li>2-speed tailstock quill</li> <li>6-way rapid traverse</li> <li>One-shot lubrication system</li> <li>Meter/inch community gear box</li> <li>Electromagnetic brake</li> <li>Carriage position device</li> <li>Thread dial indicator</li> <li>Dead center &amp; center sleeve</li> <li>Follow type splash guard</li> <li>Leadscrew cover</li> <li>Water and oil collect plate under apron</li> <li>Rear side chip and water collect plate</li> <li>Coolant system</li> <li>Halogen lamp</li> <li>Tools &amp; tool box</li> </ul>	<b>OPTIONAL ACCESSORIES</b> <ul style="list-style-type: none"> <li>3-jaw &amp; 4-jaw chuck</li> <li>Steady rest &amp; Follow rest</li> <li>Roller support</li> <li>Micrometer carriage stop</li> <li>Boring bar tool holder</li> <li>Rear chip conveyor</li> <li>Tower turret</li> <li>Compound toolpost</li> <li>2 axis toolpost</li> <li>Quick change toolpost</li> <li>Hydraulic turret (H6)</li> <li>Taper turning attachment</li> <li>Hydraulic copying attachment</li> <li>Hydraulic taper and profile base</li> <li>Semi-automatic cycle turning</li> <li>Rear adapter</li> <li>Rear safety chuck guard</li> <li>Front safety chuck guard</li> <li>Digital readout</li> <li>CE standard</li> </ul>

# HEAVY DUTY CONVENTIONAL LATHE



## 32.SWING OVER BED 2000 MM & 2050 MM

### ▼BMT 3A80



### ▼BMT 80PC

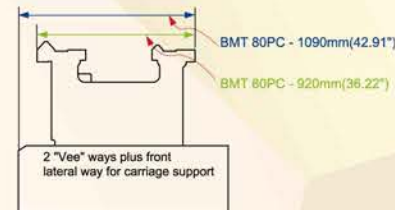
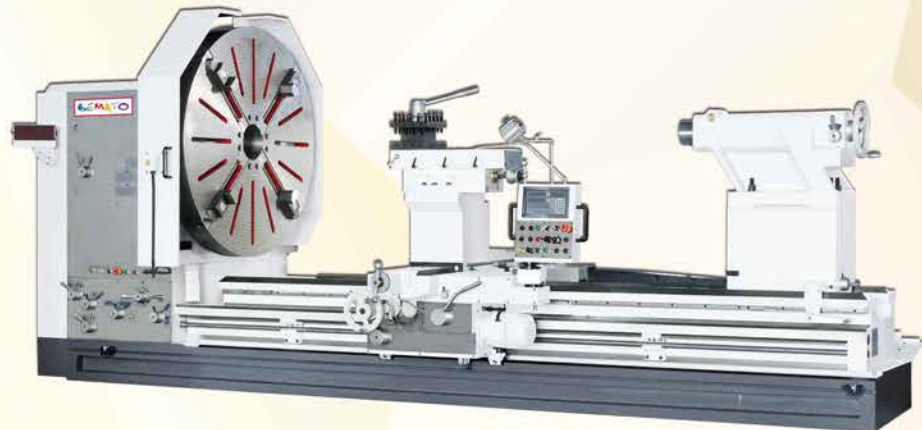

### ▼BMT 80PH

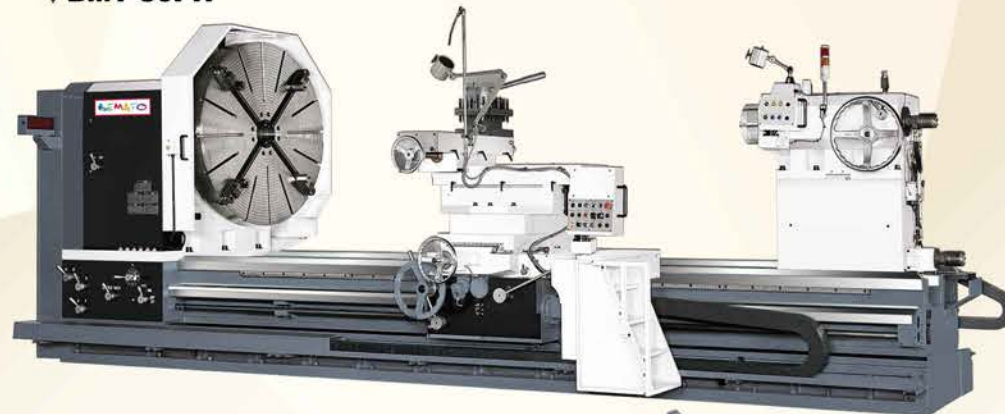

### ▼BMT 80PKA

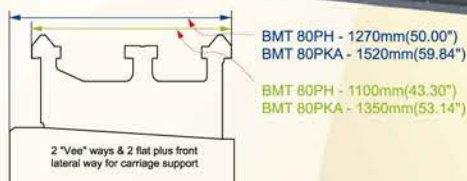
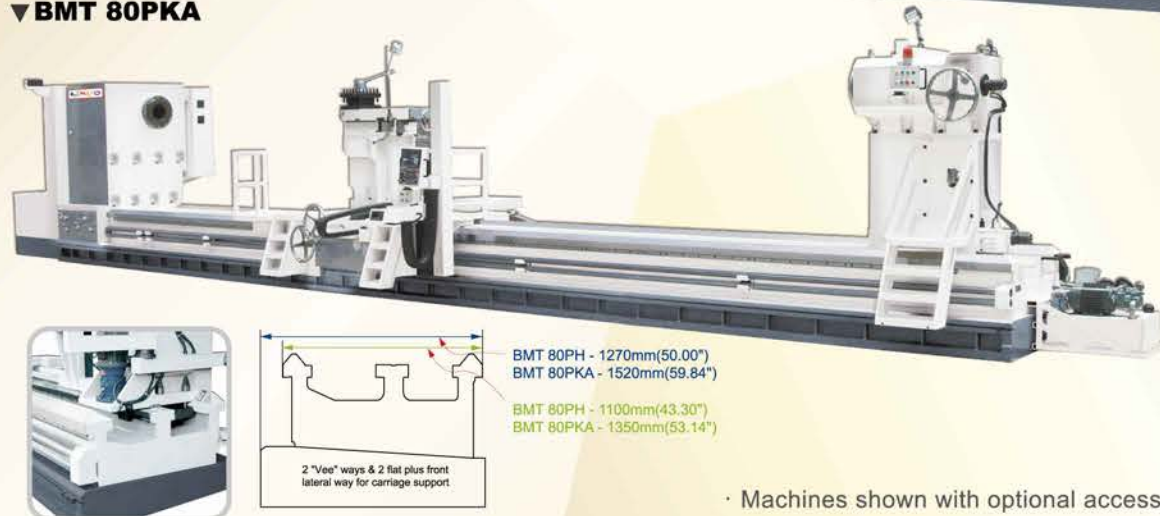

· Machines shown with optional accessories.

### SPECIFICATION:

www.e-bemato.com

Description	BMT 3A80	BMT 80PC	BMT 80PH	BMT 80PKA
Swing over bed	2000 mm	2050 mm		
Swing over cross slide (short carriage)	1550 mm	1600 mm	1720 mm	
Swing over cross slide (Long carriage)	-	-	1535 mm	1480 mm
Center height	1000 mm	1055 mm	1020 mm	
Distance between centers (DBC)	3000 / 4000 / 5000 / 6000 / 7000 / 8000 / 9000 / 10000 / 11000 / 12000 mm	1500 / 2000 / 3000 / 4000 / 5000 / 6000 / 7000 / 8000 / 9000 / 10000 / 11000 / 12000 mm	3000 / 4000 / 5000 / 6000 / 7000 / 8000 / 9000 / 10000 / 11000 / 12000 mm	
Bed width	1345 mm	920 mm	1100 mm	1350 mm
Compound rest travel	X1: 250 mm / Z1: 400 mm (auto feeding)	600 mm		700 mm
Cross slide travel	1250 mm	1170 mm	Short carriage : 415 mm / Long carriage : 1170 mm	Short carriage : 665 mm / Long carriage : 1450 mm
Spindle nose	A2-15 / A2-20 (opt.)	A2-15 / A2-20~A2-40 (opt.)		
Spindle bore	210 mm	235 mm / 255~815 mm (opt.)		
Taper of spindle bore	MT 6	-		
Spindle speed	4 steps / 5~460 rpm	18 steps / 6~480 rpm		
Taper of tailstock	MT 7	MT 6		MT 7
Tailstock quill travel	300 mm	200 mm		250 mm
Tailstock quill diameter	290 mm / 350 mm (opt.)	160 mm	235 mm	280 mm
Main motor	75 HP / 100 HP (opt.)	30 HP / 40 / 50 / 60 / 75 HP (opt.)	40 HP / 50 / 60 / 75 / 100 HP (opt.)	50 HP / 60 / 75 / 100 / 150 / 200 HP (opt.)
Coolant pump motor	1 HP	1/8 HP	1/2 HP	
Machine size (L x W x H)	L : 7627 / 8627 / 9627 / 10627 / 11627 / 12627 / 13627 / 14627 / 15627 / 16627 mm W x H : 3237 x 3967 mm	L : 4390 / 4890 / 5890 / 6890 / 7890 / 8890 / 9890 / 10890 / 11890 / 12890 / 13890 / 14890 mm W x H : 2090 x 1730 mm	L : 6370 / 7370 / 8370 / 9370 / 10370 / 11370 / 12370 / 13370 / 14370 / 15370 mm W x H : 2660 x 1820 mm	L : 6600 / 7600 / 8600 / 9600 / 10600 / 11600 / 12600 / 13600 / 14600 / 15600 mm W x H : 2815 x 2070 mm
Machine packing size (Container type)	DBC 3m, 4m : one 40' HQ + one 40' GP DBC 5m, 6m : one 40' HQ + two 40' GP DBC 7m, 8m, 9m : one 40' FR/HQ + two 40' HQ DBC 10m, 11m, 12m : four 40' HQ			
Net weight (approx.)	30 / 33.5 / 37 / 40.5 / 44 / 47.5 / 51 / 54.5 / 58 / 61.5 tons	-		
Gross weight (approx.)	31.5 / 35 / 38.5 / 42.5 / 46 / 59.5 / 53 / 56.5 / 60 / 63.5 tons	-		

\*Specifications are subject to change without prior notice.

#### BMT 3A80

##### ■ STANDARD ACCESSORIES

- 4-way toolpost
- 6-way rapid traverse
- Main motor with inverter
- Auto lubrication system
- Hydraulic spindle disk brake
- Metric/inch community gear box
- Tailstock dead center
- Tailstock rotary quill
- Motorized tailstock
- Leveling pads
- Coolant system
- Tools & tool box

##### ■ OPTIONAL ACCESSORIES

- 3-jaw & 4-jaw chuck
- Face plate
- Steady rest & Follow rest
- Boring attachment
- Grinding attachment
- Chuck guard
- Splash guard
- Digital readout
- Work light
- CE & CSA standard

#### BMT 80PH / BMT 80PC / BMT 80PKA

##### ■ STANDARD ACCESSORIES

- One piece bed, floor type casting
- 4 shear bed w/ dual way center guide & front lateral way for BMT 80PH / BMT 80PKA
- 2 shear bed w/ extra way for BMT 80PC
- Variable spindle speed through pneumatic shifting for BMT 80PH / BMT 80PKA
- Gear type headstock for BMT 80PC
- 2-speed tailstock quill
- 6-way rapid traverse
- One-shot lubrication system
- Meter/inch community gear box
- Electromagnetic brake
- Carriage position device
- Thread dial indicator
- Dead center & center sleeve
- Follow type splash guard
- Leadscrew cover
- Water and oil collect plate under apron
- Rear side chip and water collect plate
- Coolant system
- Halogen lamp
- Tools & tool box

##### ■ OPTIONAL ACCESSORIES

- 3-jaw & 4-jaw chuck
- Steady rest & Follow rest
- Roller support
- Micrometer carriage stop
- Boring bar tool holder
- Rear chip conveyor
- Tower turret
- Compound toolpost
- 2 axis toolpost
- Quick change toolpost
- Hydraulic turret (H6)
- Taper turning attachment
- Hydraulic copying attachment
- Hydraulic taper and profile base
- Semi-automatic cycle turning
- Rear adapter
- Rear safety chuck guard
- Front safety chuck guard
- Digital readout

# HEAVY DUTY CONVENTIONAL LATHE



## 33.SWING OVER BED 2250 MM & 2290 MM

### ▼ BMT 3A90

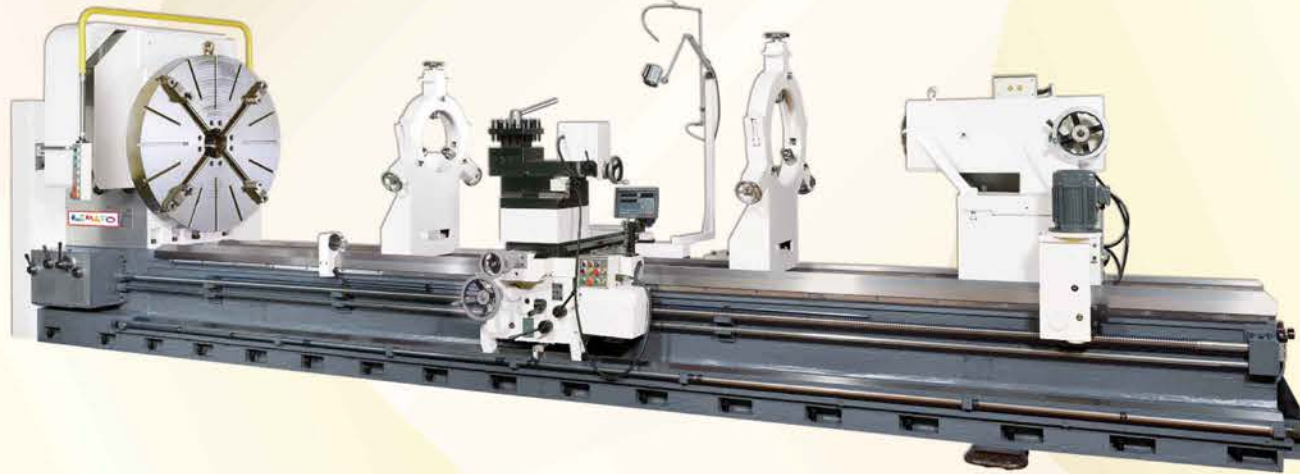

### ▼ BMT 90PKA

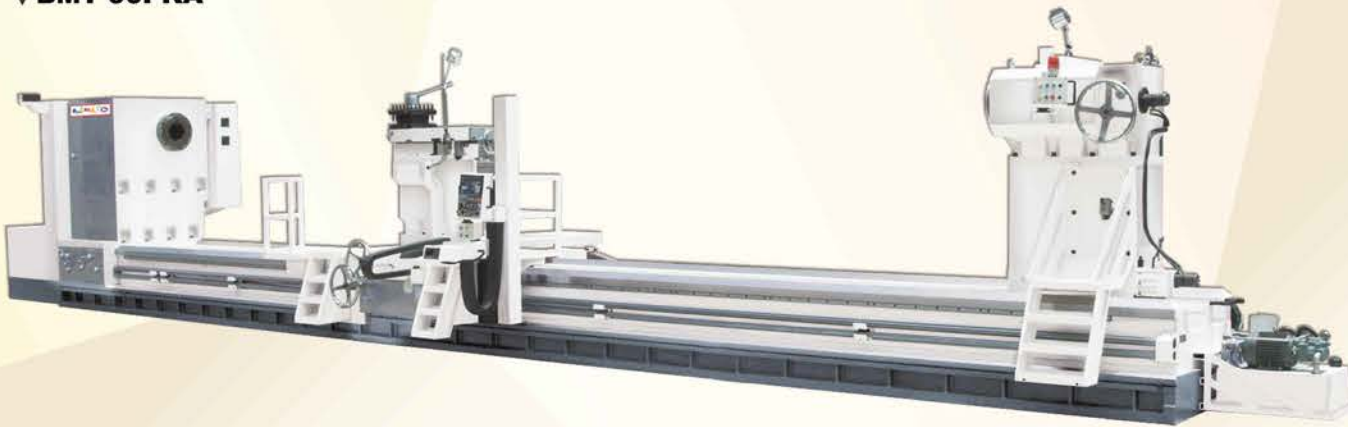

· Machines shown with optional accessories.

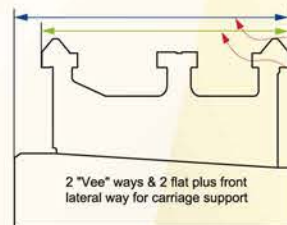

BMT 90PKA - 1520mm(59.84")

BMT 90PKA - 1350mm(53.14")

2 "Vee" ways & 2 flat plus front lateral way for carriage support

### SPECIFICATION:

Description	BMT 3A90	BMT 90PKA
Swing over bed	2250 mm	2290 mm
Swing over cross slide (short carriage)	1800 mm	1960 mm
Swing over cross slide (Long carriage)	-	1730 mm
Center height	1125 mm	1145 mm
Distance between centers (DBC)	3000 / 4000 / 5000 / 6000 / 7000 / 8000 / 9000 / 10000 / 11000 / 12000 mm	
Bed width	1345 mm	1350 mm
Compound rest travel	X1: 250 mm / Z1: 400 mm (auto feeding)	
Cross slide travel	1250 mm	Short carriage : 665 mm / Long carriage : 1450 mm
Spindle nose	A2-15 / A2-20 (opt.)	A2-15 / A2-20~A2-40 (opt.)
Spindle bore	210 mm	235 mm / 255~815 mm (opt.)
Taper of spindle bore	MT 6	-
Spindle speed	4 steps / 5~460 rpm	18 steps / 6~480 rpm
Taper of tailstock	MT 7	
Tailstock quill travel	300 mm	250 mm
Tailstock quill diameter	290 mm / 350 mm (opt.)	280 mm
Main motor	75 HP / 100 HP (opt.)	50 HP / 60 / 75 / 100 / 150 / 200 HP (opt.)
Coolant pump motor	1 HP	1/2 HP
Machine size (L x W x H)	L : 7627 / 8627 / 9627 / 10627 / 11627 / 12627 / 13627 / 14627 / 15627 / 16627 mm W x H : 3237 x 3967 mm	L : 6600 / 7600 / 8600 / 9600 / 10600 / 11600 / 12600 / 13600 / 14600 / 15600 mm W x H : 2815 x 2070 mm
Machine packing size (Container type)	DBC 3m, 4m : one 40' HQ + one 40' GP DBC 5m, 6m : one 40' HQ + two 40' GP DBC 7m, 8m, 9m : one 40' FR/HQ + two 40' HQ DBC 10m, 11m, 12m : four 40' HQ	-
Net weight (approx.)	30 / 33.5 / 37 / 40.5 / 44 / 47.5 / 51 / 54.5 / 58 / 61.5 tons	-
Gross weight (approx.)	31.5 / 35 / 38.5 / 42.5 / 46 / 49.5 / 53 / 56.5 / 60 / 63.5 tons	-

\*Specifications are subject to change without prior notice.

#### BMT 3A90

- |  |   |
|--|---|
| <ul style="list-style-type: none"> <li>■ STANDARD ACCESSORIES</li> <li>· 4-way toolpost</li> <li>· 6-way rapid traverse</li> <li>· Main motor with inverter</li> <li>· Auto lubrication system</li> <li>· Hydraulic spindle disk brake</li> <li>· Metric/inch community gear box</li> <li>· Tailstock dead center</li> <li>· Tailstock rotary quill</li> <li>· Motorized tailstock</li> <li>· Leveling pads</li> <li>· Coolant system</li> <li>· Tools &amp; tool box</li> </ul> | <ul style="list-style-type: none"> <li>■ OPTIONAL ACCESSORIES</li> <li>· 3-jaw &amp; 4-jaw chuck</li> <li>· Face plate</li> <li>· Steady rest &amp; Follow rest</li> <li>· Boring attachment</li> <li>· Grinding attachment</li> <li>· Chuck guard</li> <li>· Splash guard</li> <li>· Digital readout</li> <li>· Work light</li> <li>· CE &amp; CSA standard</li> </ul> |
|--|---|

#### BMT 90PKA

- |  |   |
|--|---|
| <ul style="list-style-type: none"> <li>■ STANDARD ACCESSORIES</li> <li>· One piece bed, floor type casting</li> <li>· 4 shear bed with dual way center guide &amp; front lateral way</li> <li>· Variable spindle speed through pneumatic shifting</li> <li>· 2-speed tailstock quill</li> <li>· 6-way rapid traverse</li> <li>· One-shot lubrication system</li> <li>· Meter/inch community gear box</li> <li>· Electromagnetic brake</li> <li>· Carriage position device</li> <li>· Thread dial indicator</li> <li>· Dead center &amp; center sleeve</li> <li>· Follow type splash guard</li> <li>· Leadscrew cover</li> <li>· Water and oil collect plate under apron</li> <li>· Rear side chip and water collect plate</li> <li>· Coolant system</li> <li>· Halogen lamp</li> <li>· Tools &amp; tool box</li> </ul> | <ul style="list-style-type: none"> <li>■ OPTIONAL ACCESSORIES</li> <li>· 3-jaw &amp; 4-jaw chuck</li> <li>· Steady rest &amp; Follow rest</li> <li>· Roller support</li> <li>· Micrometer carriage stop</li> <li>· Boring bar tool holder</li> <li>· Rear chip conveyor</li> <li>· Tower turret</li> <li>· Compound toolpost</li> <li>· 2 axis toolpost</li> <li>· Quick change toolpost</li> <li>· Hydraulic turret (H6)</li> <li>· Taper turning attachment</li> <li>· Hydraulic copying attachment</li> <li>· Hydraulic taper and profile base</li> <li>· Semi-automatic cycle turning</li> <li>· Rear adapter</li> <li>· Rear safety chuck guard</li> <li>· Front safety chuck guard</li> <li>· Digital readout</li> <li>· CE standard</li> </ul> |
|--|---|

# HEAVY DUTY CONVENTIONAL LATHE



## 34.SWING OVER BED 2500 MM ~ 2700 MM

### ▼ BMT 3A100 / BMT 3A110



### ▼ BMT 100PKA / BMT 100PKB

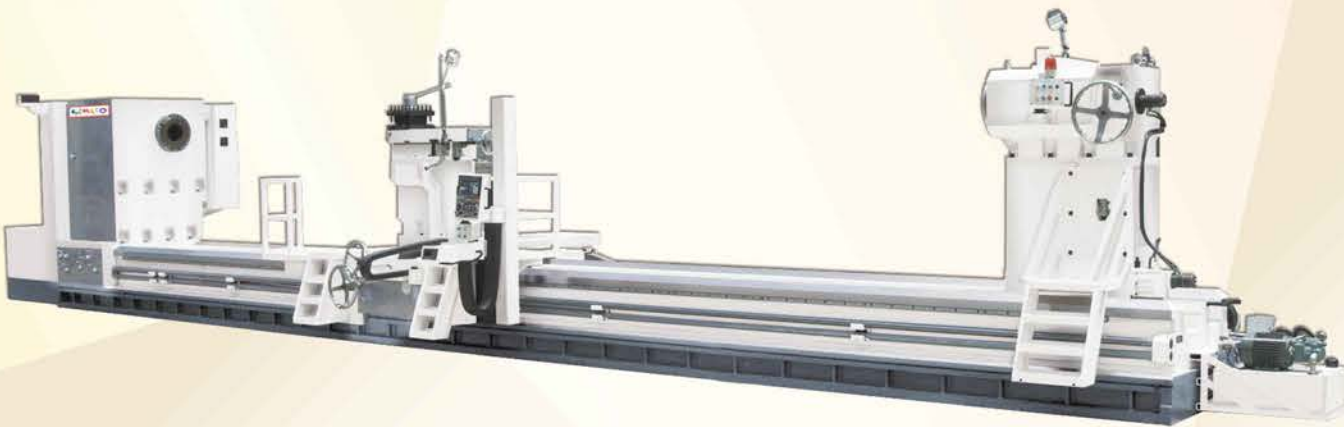

· Machines shown with optional accessories.

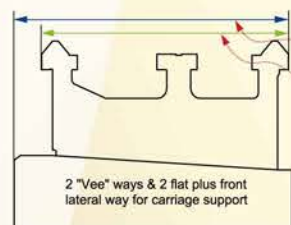

BMT 100PKA - 1520mm(59.84")  
BMT 100PKB - 1850mm(72.83")  
BMT 100PKA - 1350mm(53.14")  
BMT 100PKB - 1680mm(66.14")

2 "Vee" ways & 2 flat plus front lateral way for carriage support

### SPECIFICATION:

Description	BMT 3A100	BMT 100PKA	BMT 100PKB	BMT 3A110
Swing over bed	2500 mm	2530 mm	2560 mm	2700 mm
Swing over cross slide (short carriage)	2050 mm	2200 mm		2250 mm
Swing over cross slide (Long carriage)	-	1980 mm		-
Center height	1250 mm	1270 mm	1400 mm	1375 mm
Distance between centers (DBC)	3000 / 4000 / 5000 / 6000 / 7000 / 8000 / 9000 / 10000 / 11000 / 12000 mm			
Bed width	1345 mm	1350 mm	1680 mm	1345 mm
Compound rest travel	X1: 250 mm / Z1: 400 mm (auto feeding)	700 mm		X1: 250 mm / Z1: 400 mm (auto feeding)
Cross slide travel	1250 mm	Short carriage : 665 mm / Long carriage : 1450 mm	Short carriage : 810 mm / Long carriage : 1830 mm	1250 mm
Spindle nose	A2-15 / A2-20 (opt.)	A2-15 / A2-20~A2-40 (opt.)		A2-15 / A2-20 (opt.)
Spindle bore	210 mm	235 mm / 255~815 mm (opt.)		210 mm
Taper of spindle bore	MT 6	-		MT 6
Spindle speed	4 steps / 5~460 rpm	18 steps / 6~480 rpm		4 steps / 5~460 rpm
Taper of tailstock	MT 7			
Tailstock quill travel	300 mm	250 mm		300 mm
Tailstock quill diameter	290 mm / 350 mm (opt.)	280 mm		290 mm / 350 mm (opt.)
Main motor	75 HP / 100 HP (opt.)	50 HP / 60 / 75 / 100 / 150 / 200 HP (opt.)		75 HP / 100 HP (opt.)
Coolant pump motor	1 HP	1/2 HP		1 HP
Machine size (L x W x H)	L : 7627 / 8627 / 9627 / 10627 / 11627 / 12627 / 13627 / 14627 / 15627 / 16627 mm W x H : 3237 x 3967 mm	L : 6600 / 7600 / 8600 / 9600 / 10600 / 11600 / 12600 / 13600 / 14600 / 15600 mm W x H : 2815 x 2070 mm	L : 6600 / 7600 / 8600 / 9600 / 10600 / 11600 / 12600 / 13600 / 14600 / 15600 mm W x H : 3415 x 2770 mm	L : 7627 / 8627 / 9627 / 10627 / 11627 / 12627 / 13627 / 14627 / 15627 / 16627 mm W x H : 3237 x 3967 mm
Machine packing size (Container type)	DBC 3m, 4m : one 40' HQ + one 40' GP DBC 5m, 6m : one 40' HQ + two 40' GP DBC 7m, 8m, 9m : one 40' FR/HQ + two 40' HQ DBC 10m, 11m, 12m : four 40' HQ	-		DBC 3m, 4m : one 40' HQ + one 40' GP DBC 5m, 6m : one 40' HQ + two 40' GP DBC 7m, 8m, 9m : one 40' FR/HQ + two 40' HQ DBC 10m, 11m, 12m : four 40' HQ
Net weight (approx.)	30 / 33.5 / 37 / 40.5 / 44 / 47.5 / 51 / 54.5 / 58 / 61.5 tons	-		30 / 33.5 / 37 / 40.5 / 44 / 47.5 / 51 / 54.5 / 58 / 61.5 tons
Gross weight (approx.)	31.5 / 35 / 38.5 / 42.5 / 46 / 59.5 / 53 / 56.5 / 60 / 63.5 tons	-		31.5 / 35 / 38.5 / 42.5 / 46 / 59.5 / 53 / 56.5 / 60 / 63.5 tons

\*Specifications are subject to change without prior notice.

#### BMT 3A100 / BMT 3A110

- |  |   |
|--|---|
| <ul style="list-style-type: none"> <li>4-way toolpost</li> <li>6-way rapid traverse</li> <li>Main motor with inverter</li> <li>Auto lubrication system</li> <li>Hydraulic spindle disk brake</li> <li>Metric/inch community gear box</li> <li>Tailstock dead center</li> <li>Tailstock rotary quill</li> <li>Motorized tailstock</li> <li>Leveling pads</li> <li>Coolant system</li> <li>Tools &amp; tool box</li> </ul> | <ul style="list-style-type: none"> <li>3-jaw &amp; 4-jaw chuck</li> <li>Face plate</li> <li>Steady rest &amp; Follow rest</li> <li>Boring attachment</li> <li>Grinding attachment</li> <li>Chuck guard</li> <li>Splash guard</li> <li>Digital readout</li> <li>Work light</li> <li>CE &amp; CSA standard</li> </ul> |
|--|---|

#### BMT 100PKA / BMT 100PKB

- |  |   |
|--|---|
| <ul style="list-style-type: none"> <li>One piece bed, floor type casting</li> <li>4 shear bed w/ dual way center guide &amp; front lateral way</li> <li>Variable spindle speed through pneumatic shifting</li> <li>2-speed tailstock quill</li> <li>6-way rapid traverse</li> <li>One-shot lubrication system</li> <li>Meter/inch community gear box</li> <li>Electromagnetic brake</li> <li>Carriage position device</li> <li>Thread dial indicator</li> <li>Dead center &amp; center sleeve</li> <li>Follow type splash guard</li> <li>Leadscrew cover</li> <li>Water and oil collect plate under apron</li> <li>Rear side chip and water collect plate</li> <li>Coolant system</li> <li>Halogen lamp</li> <li>Tools &amp; tool box</li> </ul> | <ul style="list-style-type: none"> <li>3-jaw &amp; 4-jaw chuck</li> <li>Steady rest &amp; Follow rest</li> <li>Roller support</li> <li>Micrometer carriage stop</li> <li>Boring bar tool holder</li> <li>Rear chip conveyor</li> <li>Tower turret</li> <li>Compound toolpost</li> <li>2 axis toolpost</li> <li>Quick change toolpost</li> <li>Hydraulic turret (H6)</li> <li>Taper turning attachment</li> <li>Hydraulic copying attachment</li> <li>Hydraulic taper and profile base</li> <li>Semi-automatic cycle turning</li> <li>Rear adapter</li> <li>Rear safety chuck guard</li> <li>Front safety chuck guard</li> <li>Digital readout</li> <li>CE standard</li> </ul> |
|--|---|

# HEAVY DUTY CONVENTIONAL LATHE



## 35.SWING OVER BED 3060 MM & 3560 MM

### ▼ BMT 120PKB / BMT 140PKB

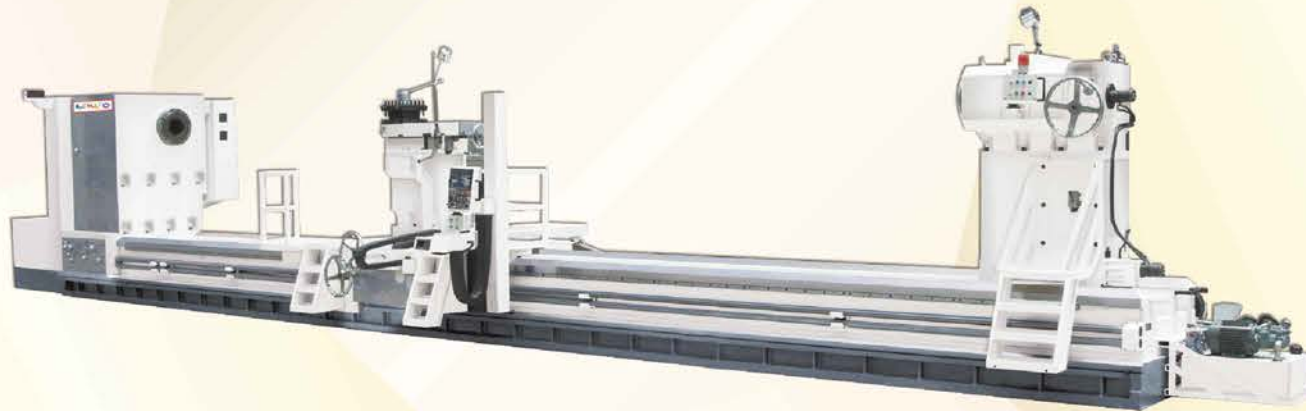

· Machines shown with optional accessories.

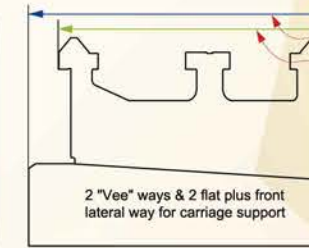

BMT 120PKB & BMT 140PKB - 1850mm(72.83")

BMT 120PKB & BMT 140PKB - 1680mm(66.14")

### SPECIFICATION:

Description	BMT 120PKB	BMT 140PKB
Swing over bed	3060 mm	3560 mm
Swing over cross slide (short carriage)	2700 mm	3190 mm
Swing over cross slide (Long carriage)	2480 mm	2980 mm
Center height	1650 mm	1900 mm
Distance between centers	3000 / 4000 / 5000 / 6000 / 7000 / 8000 / 9000 / 10000 / 11000 / 12000 mm	
Bed width	1680 mm	
Compound rest travel	700 mm	
Cross slide travel	Short carriage : 810 mm / Long carriage : 1830 mm	
Spindle nose	A2-15 / A2-20~A2-40 (opt.)	
Spindle bore	235 mm / 255~815 mm (opt.)	
Spindle speed	18 steps / 6~480 rpm	
Taper of tailstock	MT 7	
Tailstock quill travel	250 mm	
Tailstock quill diameter	280 mm	
Main motor	50 HP / 60 / 75 / 100 / 150 / 200 HP (opt.)	
Coolant pump motor	1/2 HP	
Machine size (L x W x H)	L : 6600 / 7600 / 8600 / 9600 / 10600 / 11600 / 12600 / 13600 / 14600 / 15600 mm W x H : 3415 x 2770 mm	

\*Specifications are subject to change without prior notice.



▲ Taper Turning Attachment +/- 7 degrees  
Travel 500mm (19.69")

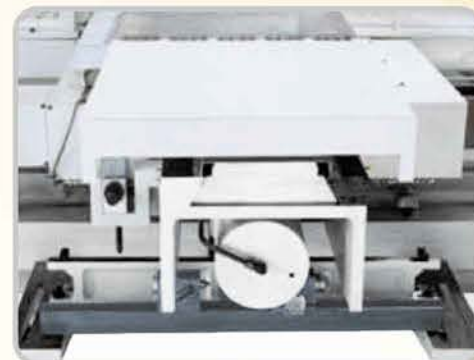

▲ Hydraulic Copying Turning System  
1:1 ratio

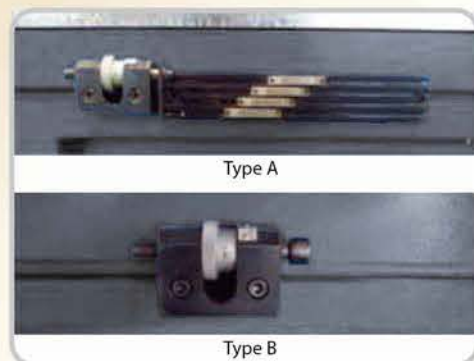

▲ Micrometer Carriage Stop  
(Positioning system and auto power off)

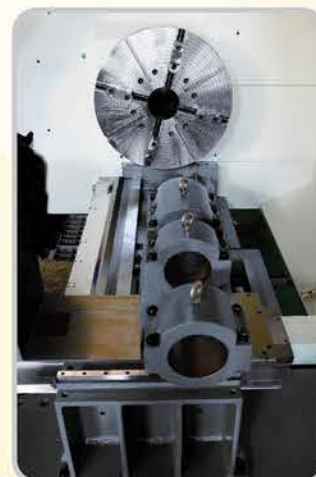

▲ Boring Bar Tool Holder

### BMT 120PKB / BMT 140PKB

#### ■ STANDARD ACCESSORIES

- One piece bed, floor type casting
- 4 shear bed with dual way center guide & front lateral way
- Variable spindle speed through pneumatic shifting
- 2-speed tailstock quill
- 6-way rapid traverse
- One-shot lubrication system
- Meter/inch community gear box
- Electromagnetic brake
- Carriage position device
- Thread dial indicator
- Dead center & center sleeve
- Follow type splash guard
- Leadscrew cover
- Water and oil collect plate under apron
- Rear side chip and water collect plate
- Coolant system
- Halogen lamp
- Tools & tool box

#### ■ OPTIONAL ACCESSORIES

- 3-jaw & 4-jaw chuck
- Steady rest & Follow rest
- Roller support
- Micrometer carriage stop
- Boring bar tool holder
- Rear chip conveyor
- Tower turret
- Compound toolpost
- 2 axis toolpost
- Quick change toolpost
- Hydraulic turret (H6)
- Taper turning attachment
- Hydraulic copying attachment
- Hydraulic taper and profile base
- Semi-automatic cycle turning
- Rear adapter
- Rear safety chuck guard
- Front safety chuck guard
- Digital readout
- CE standard

