

FUL Series

CNC LATHE

SINGLE SPINDLE / SINGLE TURRET

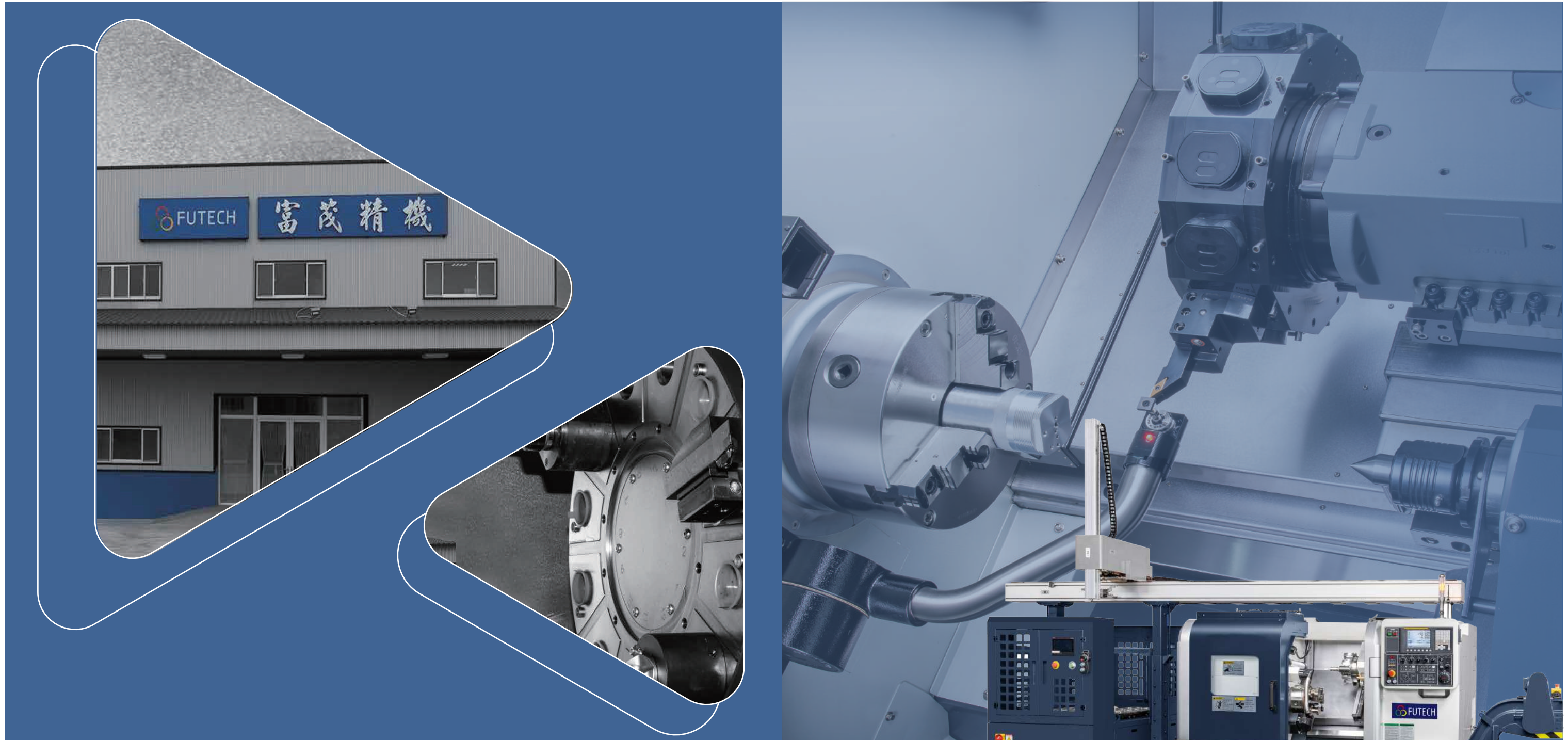

HIGH PRECISION CNC LATHE

SINGLE SPINDLE & SINGLE TURRET CONFIGURATION

FUL - 20

Gantry loading & unloading system
(Opt.)



FUL-15.20.25.30 Series »



FUL-36.38 Series «



FUL-36.38 Series »



» The design concept behind FUL series CNC lathe is to enhance high speed and high accuracy. The series of machine is designed with single spindle and single turret.

» It's 45 degree slant bed construction features high rigidity and high stability. X, Z-axis are mounted with ball type linear guide ways or box guide ways. Axis movement is directly driven by a servo motor, allowing the high rapid traverse rates on X, Z-axis.

» Each machine in the FUL series is equipped with a high precision, high speed spindle, enabling the FUL series to exhibit outstanding performance in high speed and high efficiency machining.

OPTIMIZED STRUCTURE DESIGN

THE ULTIMATE IN RIGIDITY AND STABILITY

- » The major machine parts, such as the base, saddle, headstock, slide and tailstock are made of Meehanite cast iron and are tempered to relieve stress thereby ensuring lifetime accuracy.
- » High performance servo motors are directly coupled to the pre-tensioned ball screws.

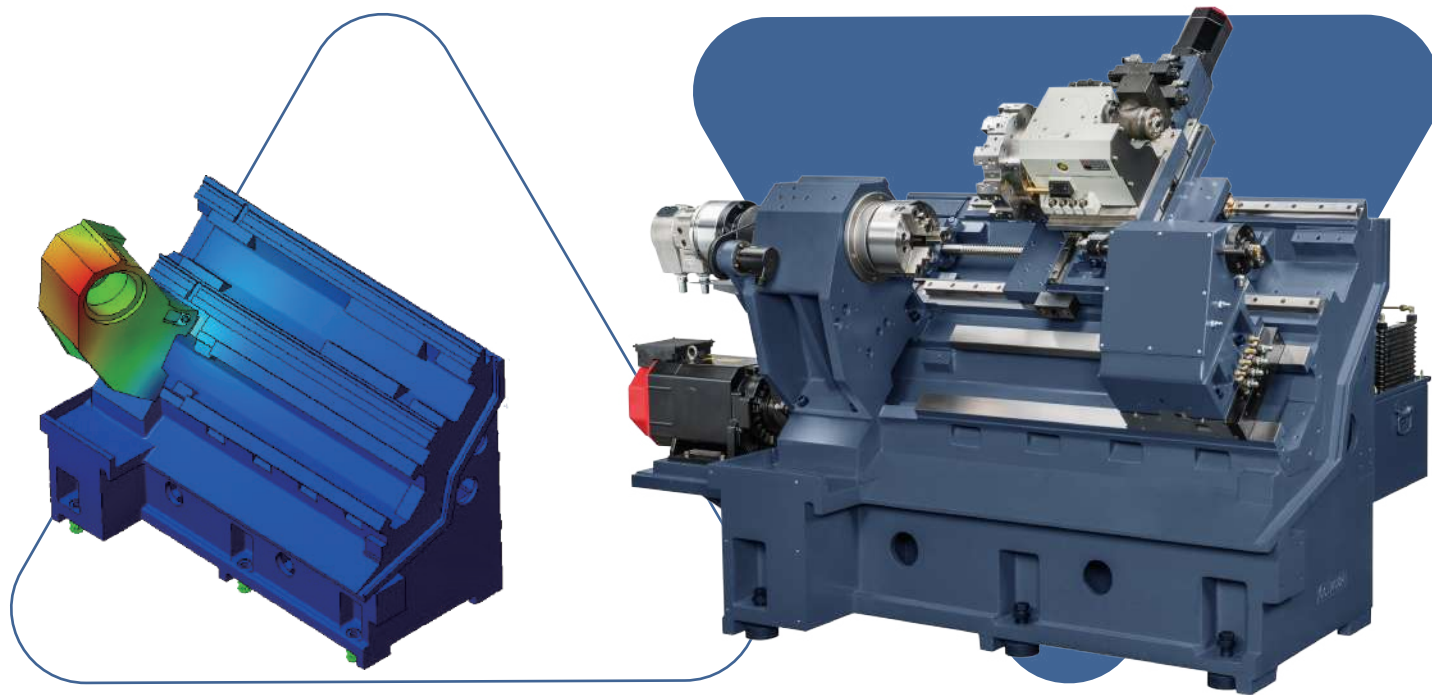

- » Choice of linear guideways or box guideways on X and Z axis.
- » 45 degree slant bed construction features efficient chip removal and firm support.

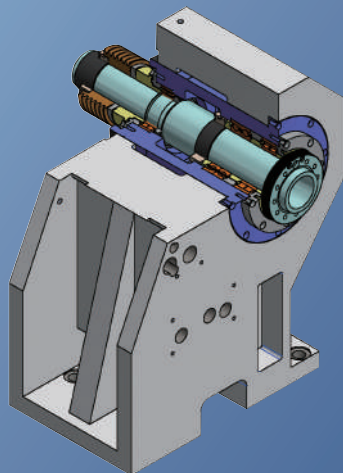
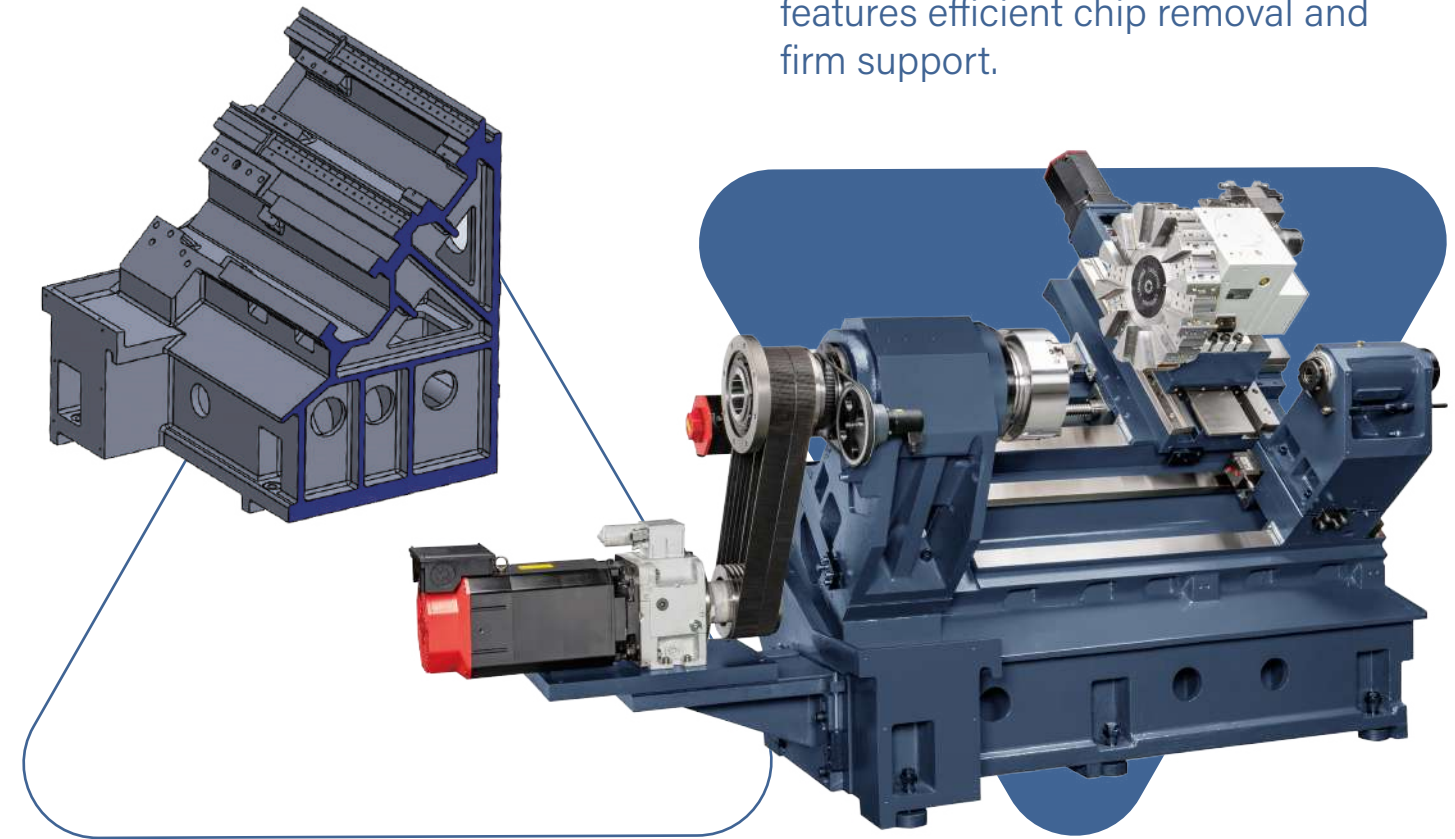

Precision Spindle

- » The cartridge type is easily removed allowing and conveniently maintained servicing.
- » The spindle runs on class p4 precision bearings providing high axial thrust capacity and superior radial stability. This ensures high precision during heavy duty turning.

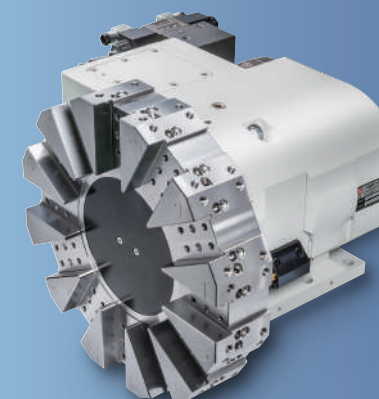

Hydraulic Turret 8-Position Hydraulic Turret (FUL-15/20)

- » The 8-position turret features bi-directional random tool selection. Fast tool positioning can be accomplished in only 1 second for upgrading efficiency.
- » The turret can accommodate 25 x 25 mm O.D. tools and Ø32 mm I.D. tools.

12-Position Hydraulic Turret (FUL-25/30/36/38)

- » The 12-position turret features bi-directional random tool selection. Fast tool positioning can be accomplished in only 1 second for upgrading efficiency.
- » The turret can accommodate 25 x 25 mm and 040 mm I.D. tools. (FUL-25/30)
- » The turret can accommodate 32 x 32 mm and 050 mm I.D. tools. (FUL-36/38)

TOOLING SYSTEM

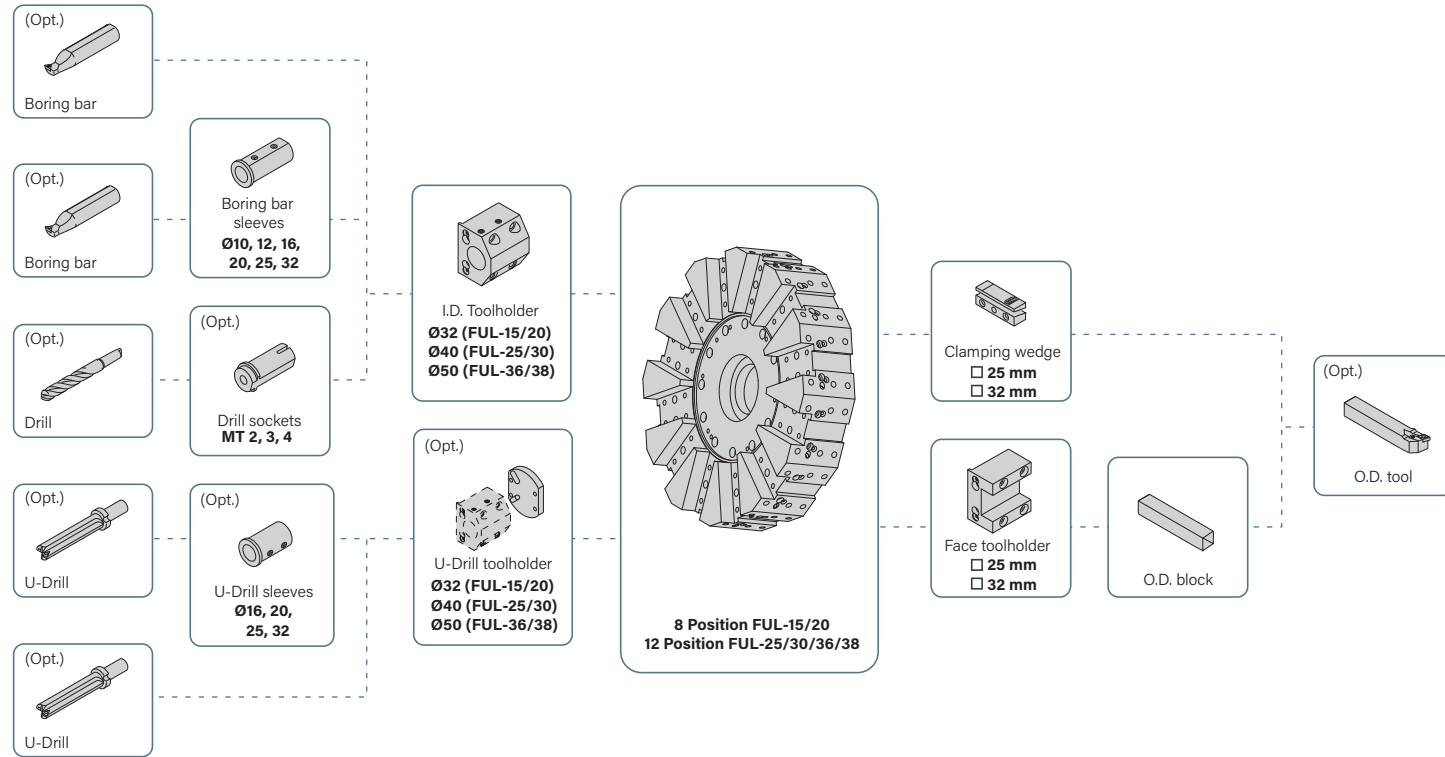

WORKING CAPACITY

The below interference drawing is only for reference. Please confirm correct details with business services.

FUL-15 Series

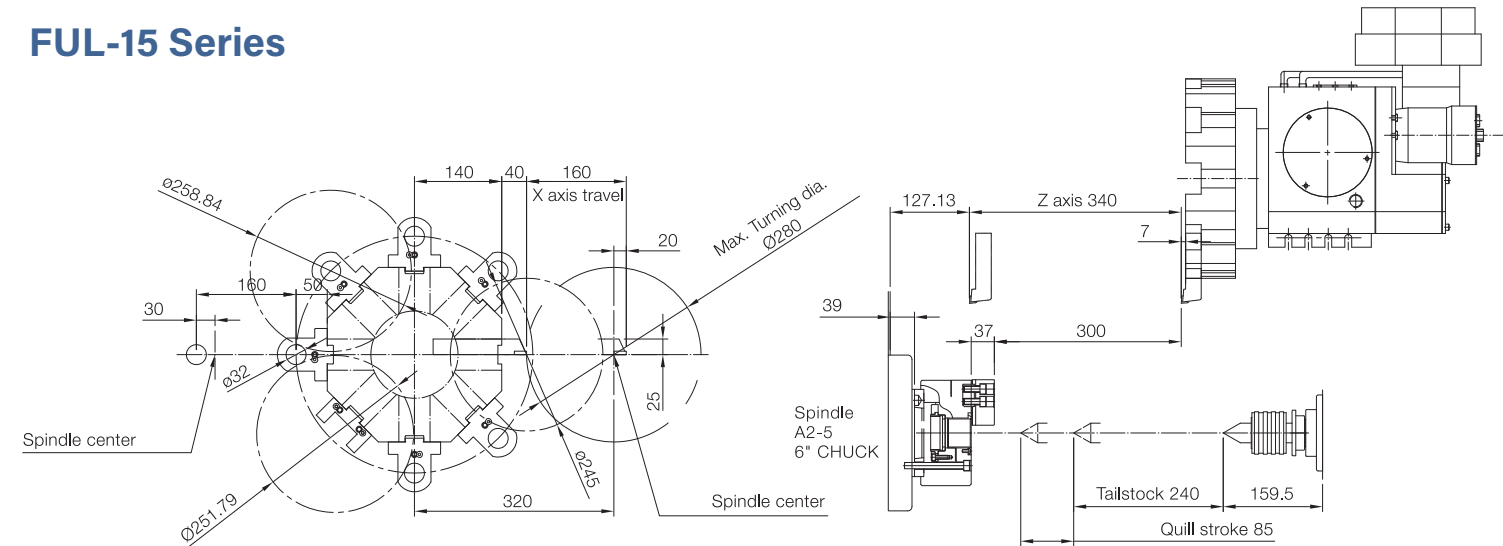

FUL-20 Series

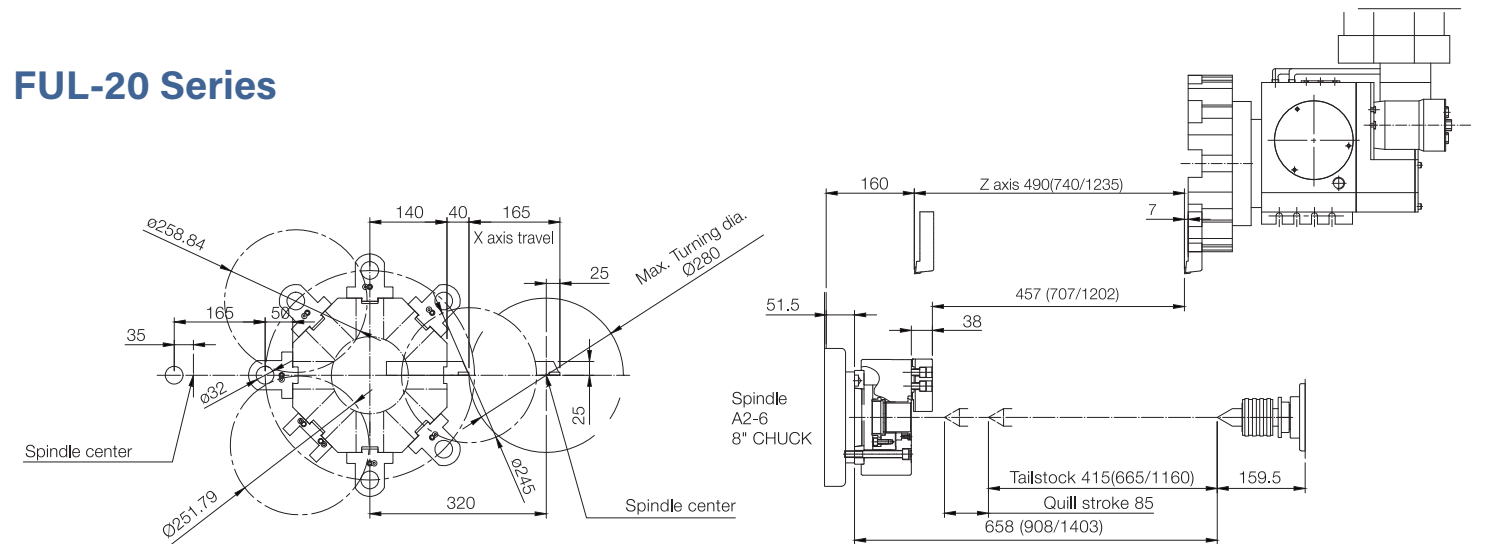

DIMENSIONAL DRAWINGS

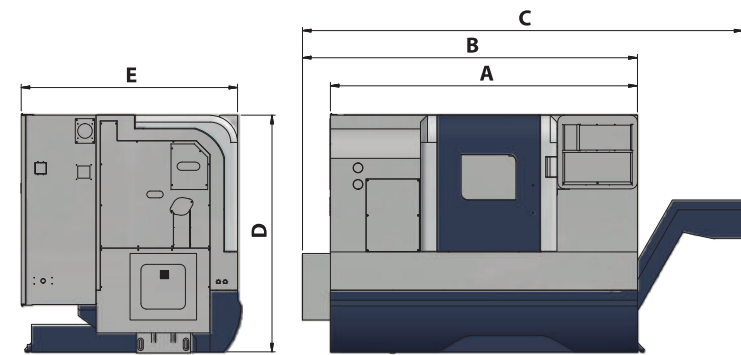

Model	A	B	C	D	E
FUL-1503	1600	1850	2800	1737	1575
FUL-2004	2235	2438	3206	1737	1575
FUL-2007	2800	2970	3738	1737	1575
FUL-2504	2430	2600	3433	2038	1823
FUL-2507	2730	2900	3733	2038	1823
FUL-2512	3600	3750	4744	1980	1870
FUL-3007	2930	3100	3928	2038	1823
FUL-3012	3600	3770	4764	2038	1870
FUL-3607	2760	3354	4181	2090	1896
FUL-3807	2760	3354	4181	2090	1896
FUL-3612	4000	4000	4800	2090	1945
FUL-3812	4000	4000	4800	2090	1945
FUL-3622	5000	5000	5800	2090	1945
FUL-3822	5000	5000	5800	2090	1945

»The above interference drawing only for reference. Please confirm correct details with the business service.

FUL-15

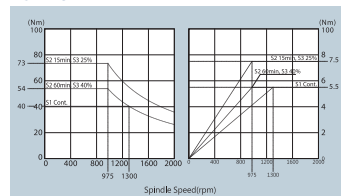

FUL-20S

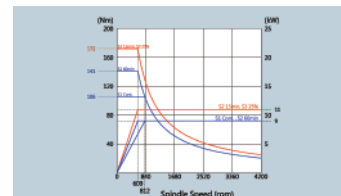

FUL-25S

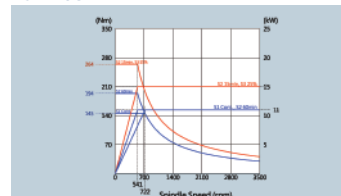

FUL-30S

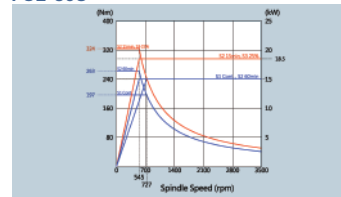

FUL-36S

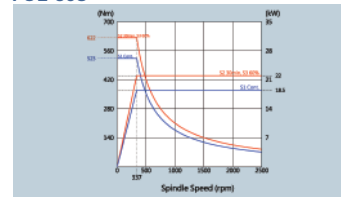

FUL-38S

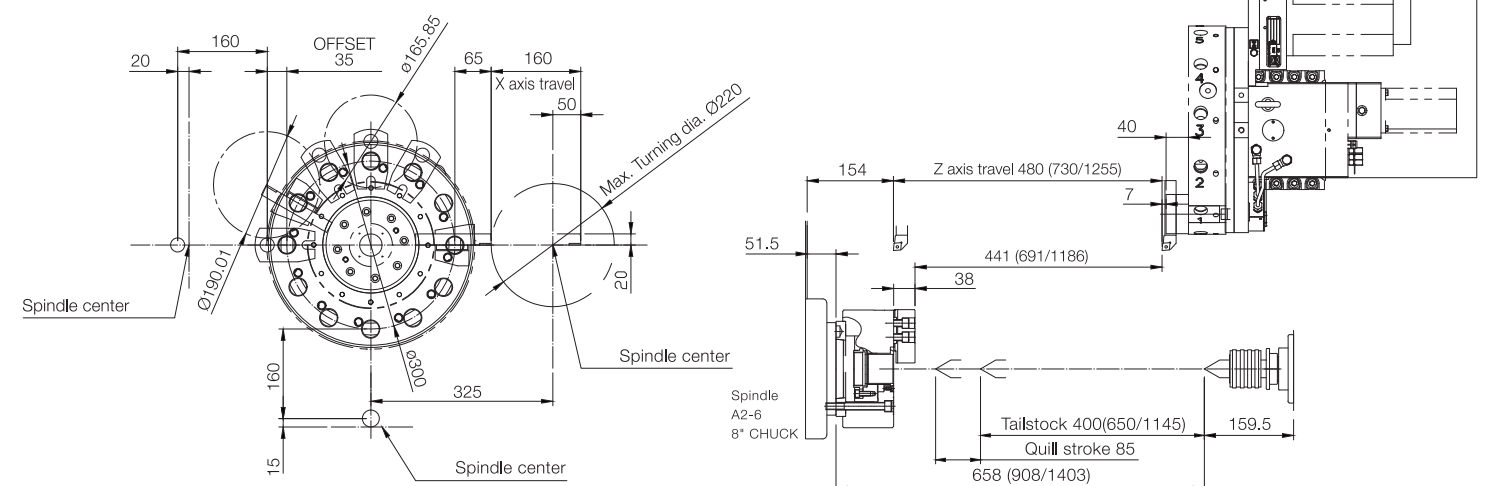
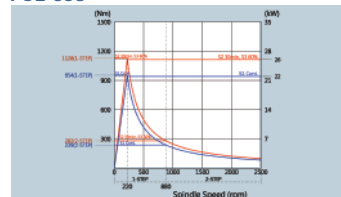

WORKING CAPACITY

FUL-25 Series »

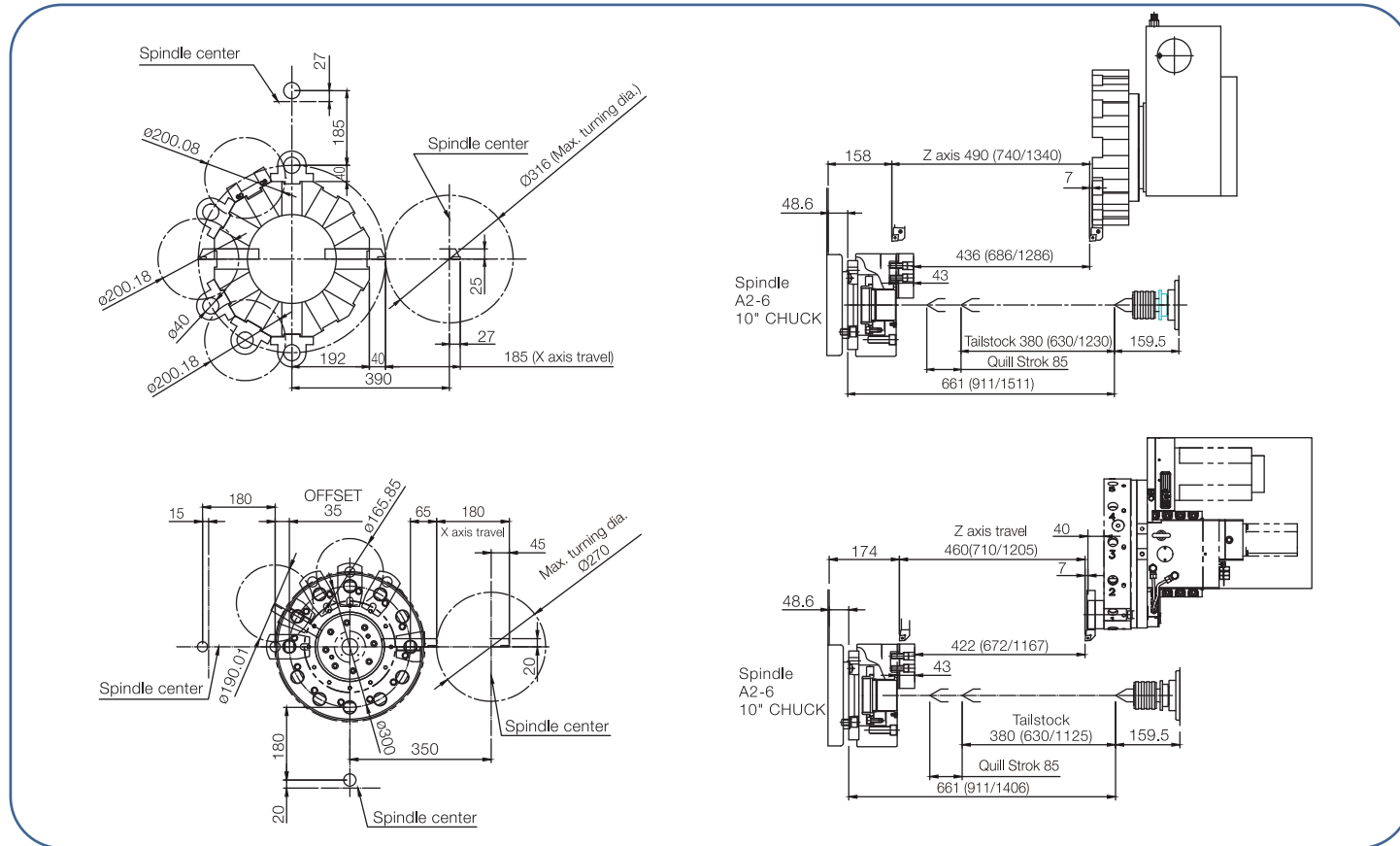

FUL-36 Series »

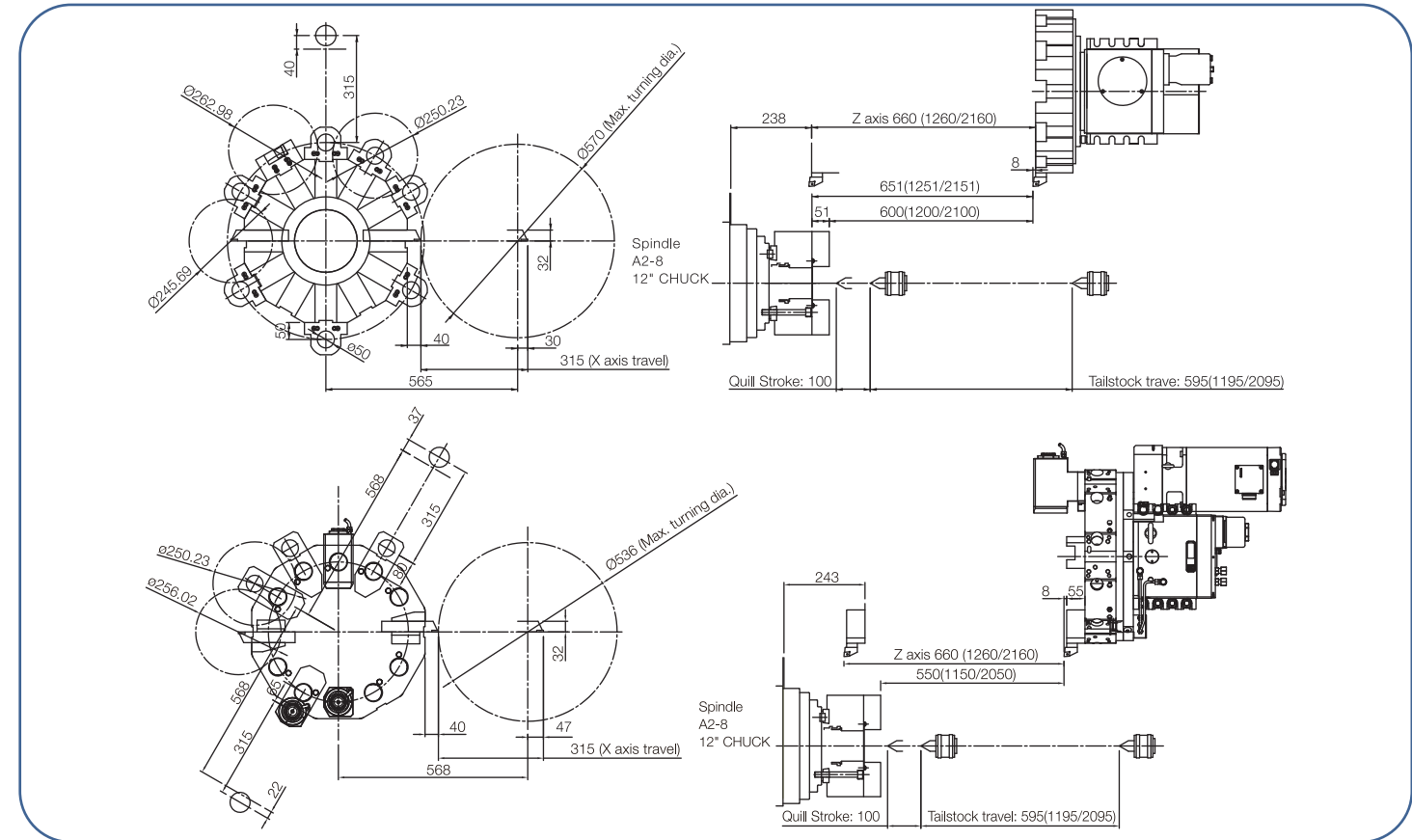

FUL-30 Series »

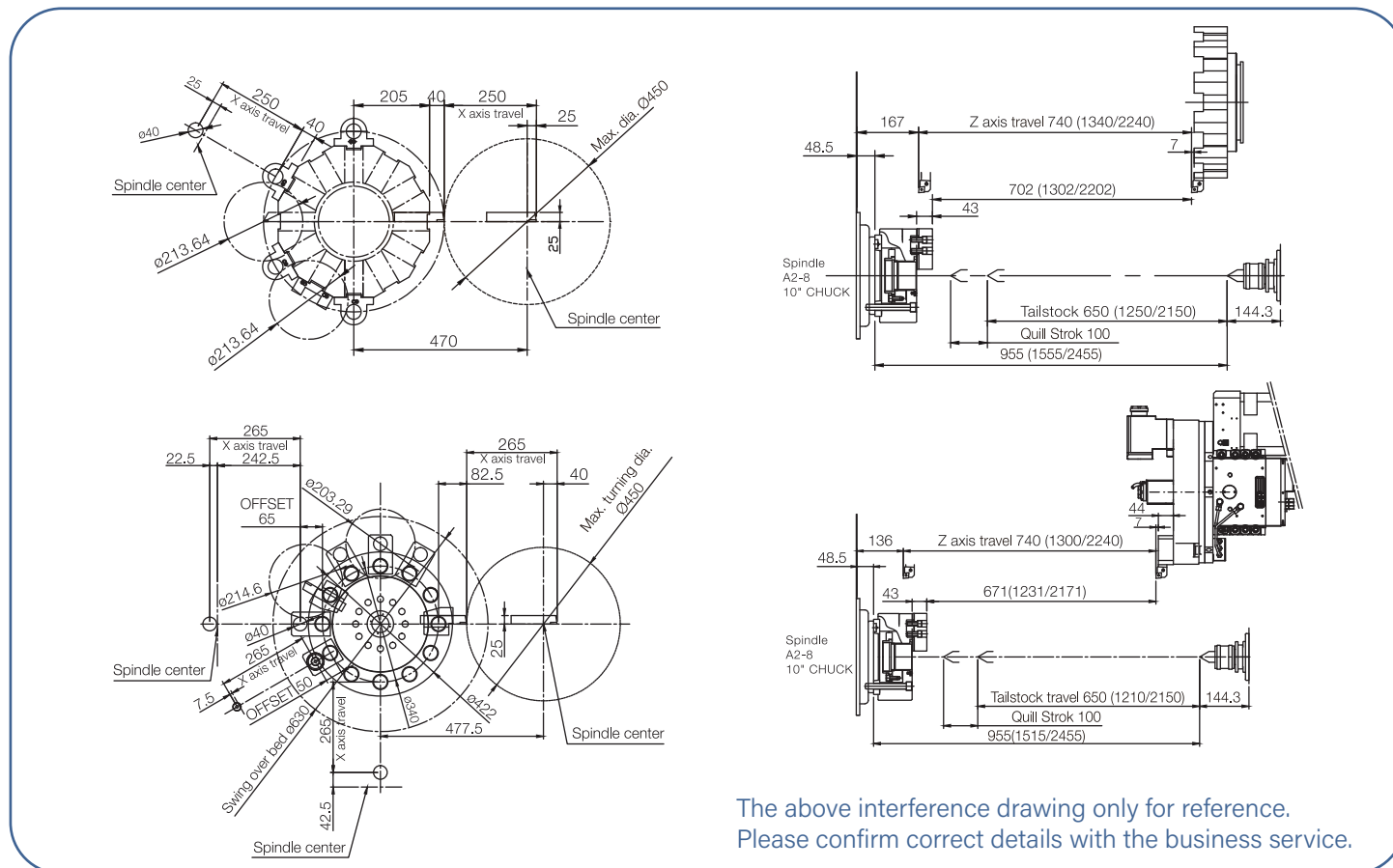

The above interference drawing only for reference. Please confirm correct details with the business service.

FUL-38 Series »

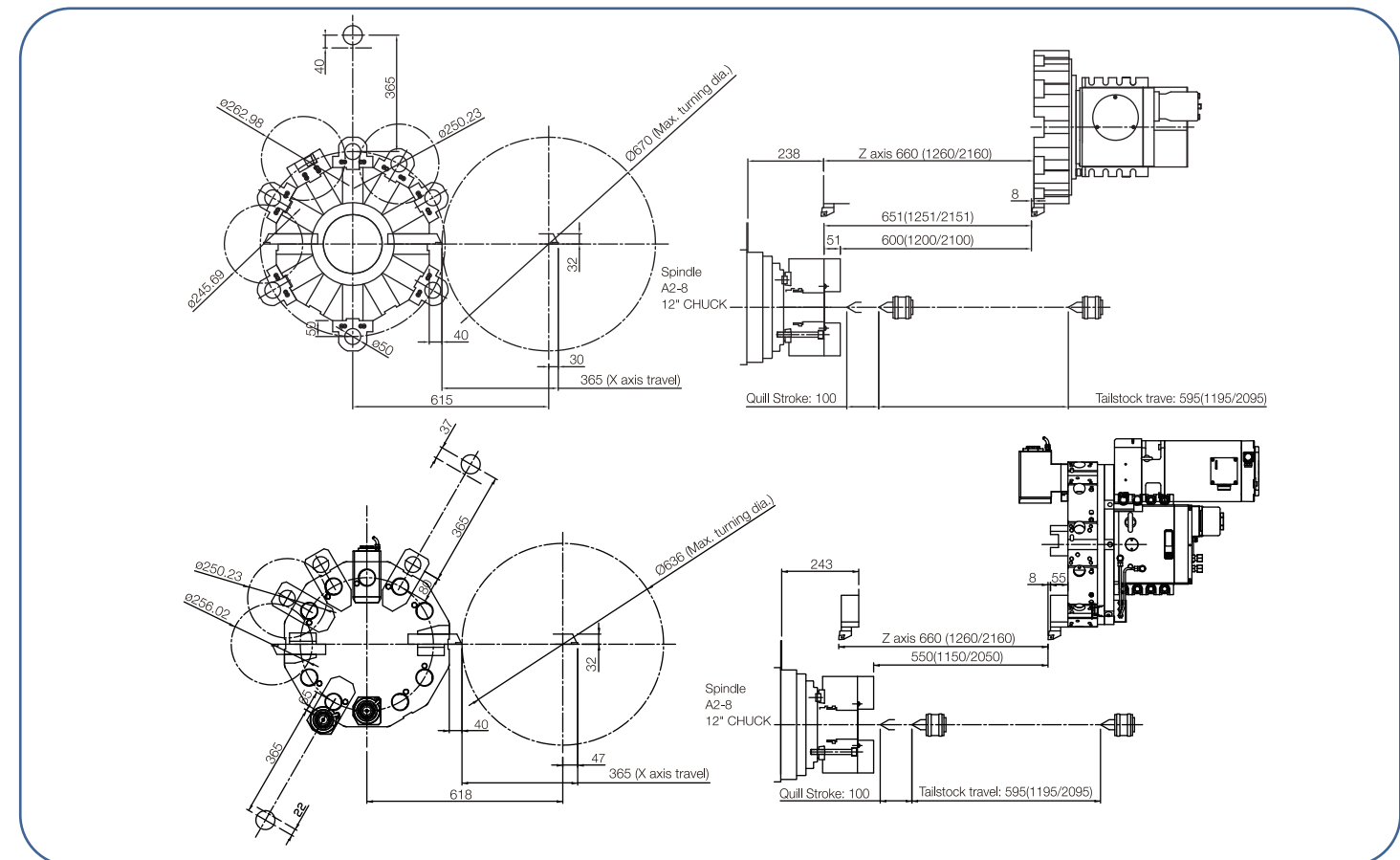

SPECIFICATIONS

MODEL	UNIT	FUL-15	FUL-20		FUL-25			FUL-30			FUL-36			FUL-38			
		FUL-1503	FUL-2004	FUL-2007	FUL-2504	FUL-2507	FUL-2512	FUL-3007	FUL-3012	FUL-3022	FUL-3607	FUL-3612	FUL-3622	FUL-3807	FUL-3812	FUL-3822	
Capacity	No. of axis		2 axis	2 axis / opt. 3 axis (C axis)		2 axis / opt. 3 axis (C axis)			2 axis / opt. 3 axis (C axis)			2 axis / opt. 3 axis (C axis)					
	Swing over bed	mm (in)	Ø460 (18.11")	Ø460 (18.11")		Ø600 (23.62")			Ø630 (24.8")			Ø770 (30.3")			Ø840 (33")		
	Swing over saddle	mm (in)	Ø275 (10.8")	Ø275 (10.8")		Ø450 (17.7")			Ø440 (17.3")			Ø590 (23.22")			Ø670 (26.37")		
	Max. turning dia.	mm (in)	Ø280 (11.02")	Ø280 (11.02")		Ø316 (12.44")			Ø450 (17.72")			Ø570 (22.44")			Ø670 (26.37")		
	Working length	mm (in)	300 (11.8")	455 (17.9")	690 (27.16")	435 (17.12")	690 (27.16")	1290 (50.78")	700 (27.55")	1300 (51.18")	2200 (86.6")	600 (23.6")	1200 (47.2")	2100 (82.7")	600 (23.6")	1200 (47.2")	2100 (82.7")
	Guide way	type	LINEAR	LINEAR / BOX		LINEAR / BOX			LINEAR / BOX		BOX	BOX			BOX		
Spindle	Spindle nose	ISO	A2-5	A2-6		A2-6			A2-8			A2-8 / Opt.: A2-11			A2-8 / Opt.: A2-11		
	Spindle bore	mm (in)	Ø56 (2.2")	Ø61 (2.4")		Ø77 (3.03")			Ø90 (3.54") / Opt.: Ø101 (3.97")			Ø101 (3.97") / Opt.: Ø131 (5.15")			Ø101 (3.97") / Opt.: Ø131 (5.15")		
	Bar capacity	mm (in)	Ø45 (1.77")	Ø52 (2")		Ø65 (2.56")			Ø77 (3.08") / Opt.: Ø91 (3.58")			Ø91 (3.58") / Opt.: Ø117 (4.6")			Ø91 (3.58") / Opt.: Ø117 (4.6")		
	Range of spindle speed	rpm	6000 rpm	4200		3500			3500 / Opt.: 2500			2500 / Opt.: 2000			2500 / Opt.: 2000		
	Living tools speed (opt.)	rpm	NONE	4000	4000	4000	4000	4000	4000			4000			4000		
Chuck	Hydraulic chuck	mm (in)	Ø169 (6")	Ø210 (8")		Ø254 (10")			Ø254 (10") / Opt.: Ø304 (12")			Ø304 (12") / OP: Ø381 (15")			Ø304 (12") / Opt.: Ø381 (15")		
Turret	Tool station (Random)	station	8T	8T (Opt.: servo turret / power turret)		12T (Opt.: servo turret / power turret)			12T / (Opt.: servo turret / power turret)			12T / (Opt.: servo turret / power turret)			12T / (Opt.: servo turret / power turret)		
	O.D. tooling	mm (in)	□25 × 25	□25 × 25		□25 × 25			□25 × 25			□32 × 32			□32 × 32		
	I.D tooling	mm (in)	Ø32 (1.25")	Ø32 (1.25")		Ø40 (1.5")			Ø40 (1.5")			Ø50 (2")			Ø50 (2")		
Cross slide (X-axis) & Carriage (Z-axis)	X-axis travel	mm (in)	160 (140+20) (6.3")	165 (140+25) (6.49")		185 (158+27) (7.28")			250 (225+25) (9.84")			315 (285+30) (12.4")			365 (335+30) (14.4")		
	Z-axis travel	mm (in)	340 (13.3")	490 (19.3")	740 (29.13")	490 (19.3")	740 (29.13")	1340 (52.75")	740 (29.1")	1340 (52.75")	2240 (88.19")	660 (26")	1260 (49.6")	2160 (85")	660 (26")	1260 (49.6")	2160 (85")
	Rapid traverse speed (X-axis)	m/min	30	30 (LINEAR) / 24 (BOX)		30 (LINEAR) / 24 (BOX)			30 (LINEAR) / 24 (BOX)		24 (BOX)	24			24		
	Rapid travers speed (Z-axis)	m/min	30	30 (LINEAR) / 20 (BOX)		30 (LINEAR) / 20 (BOX)			30 (LINEAR) / 20 (BOX)		12 (BOX)	20	20	12	20	20	12
	Cutting feed rate (Both-axis)	mm/rev	0.001-500	0.001-500		0.001-500			0.001-500			0.001-500			0.001-500		
	Dia. of ball screw (X-axis)	mm/rev	Ø32(1.26") P10	Ø32 (1.26") P10		Ø32 (1.26") P10			Ø32 (1.26") P10			Ø36 (1.42") P10			Ø36 (1.42") P10		
Dia. of ball screw (Z-axis)	mm (in)	Ø36(1.42") P10	Ø36 (1.42") P10		Ø36 (1.42") P10			Ø40 (1.57") P10	Ø36 (1.42") P10	Ø40 (1.57") P10	Ø50 (1.97") P10	Ø40 (1.57") P10	Ø40 (1.57") P10	Ø50 (1.97") P10	Ø40 (1.57") P10	Ø40 (1.57") P10	Ø50 (1.97") P10
Motor	Spindle	kW	β6il (5.5/7.5)	βP18i (9/11)		βP22i (11/15)			βP30i (15/18.5)			αP40i (18.5/22)			α22i(22/26) + 2-SPEED GEARBOX		
	X-axis	kW	β8Bis (1.2)	β12Bis (1.8)		β12Bis (1.8)			β22Bis (2.5)			α22Bi (4)			α22Bi (4)		
	Z-axis	kW	β8is (1.2)	β12is (1.8)		β12is (1.8)			β22Bis (2.5)			α22i (4)			α22i (4)		
	Hydraulic oil pump	kW (HP)	1.5 (2)	1.5 (2)		1.5 (2)			1.5 (2)			1.5 (2)			1.5 (2)		
	Coolant pump	W (HP)	750 (1)	750 (1)		750 (1)			750 (1)			750 (1)			750 (1)		
Tailstock	Quill dia.	mm (in)	Ø75(2.95")(OP.)	Ø75 (2.95")		Ø75 (2.95")			Ø90 (3.54")			100 (3.94")			100 (3.94")		
	Quill stroke	mm (in)	85(3.35")(OP.)	85 (3.35")		85 (3.35")			100 (3.94")			100 (3.94")			100 (3.94")		
	Taper of center		MT no.4 (OP.)	MT no.4		MT no.4			MT no.5			MT no.5			MT no.5		
	Tailstock travel	mm (in)	240 (9.44")(OP.)	415 (16.3")	660 (26")	380 (14.96")	630 (24.8")	1230 (48.42")	650 (25.6")	1250 (49.2")	2150 (84.65")	595 (23.4")	1195 (47.04")	2095 (82.48")	595 (23.4")	1195 (47.04")	2095 (82.48")
Tank Capacity	Hydraulic Tank	Liter	40	40	60	60			60			60			60		
	Coolant tank	Liter	110	115	180	190	250	300	250	330	420	280	375	520	280	375	520
Dimensions	Length * width	mm	1850 x 1600	2440 x 1600	2900 x 1600	2600 x 1845	2900 x 1845	3800 x 1845	3100 x 1845	3770 x 1845	4800 x 1845	3100 x 1945	3770 x 1945	5000 x 1945	3350 x 1945	4020 x 1945	5050 x 1945
	Height	mm (in)	1737 (68.4")	1737 (68.4")		2050 (80.7")			2050 (80.7")			2100 (82.67")			2100 (82.67")		
	Weight (NW/GW)	kgs	3600 / 4050	4500 / 5050	5100 / 5460	5000 / 5300	5600 / 5960	6500 / 7000	5600 / 5870	6500 / 7000	8300 / 9100	6600 / 6870	7500 / 8000	8400 / 9300	7200 / 7470	8100 / 8600	9000 / 9900

» All specification, design and characteristics shown on this catalogue are subject to change without prior notice.

MACHINE FEATURES

» STANDARD ACCESSORIES

- 3 bar-750w coolant pump
- Coolant tank
- Hydraulic turret 8-position / 12-Position
- Automatic lubrication system
- Tools & tool box
- Working light
- Three color alarm light
- Hydraulic unit
- Heat exchanger for electric cabinet
- Chip conveyor and bucket

» OPTIONAL ACCESSORIES

- Programmable tailstock
- C.E. electric control
- Automatic tool setter
- C axis and TD axis contour capability
- Main power transformer
- Automatic door & safety switch
- Larger hydraulic chuck
- Servo turret
- Manual tailstock
- Automatic parts catcher
- Prevent crash install of each axis (safety equipment)
- Bar feeder Parts cut off detector
- Larger spindle motor

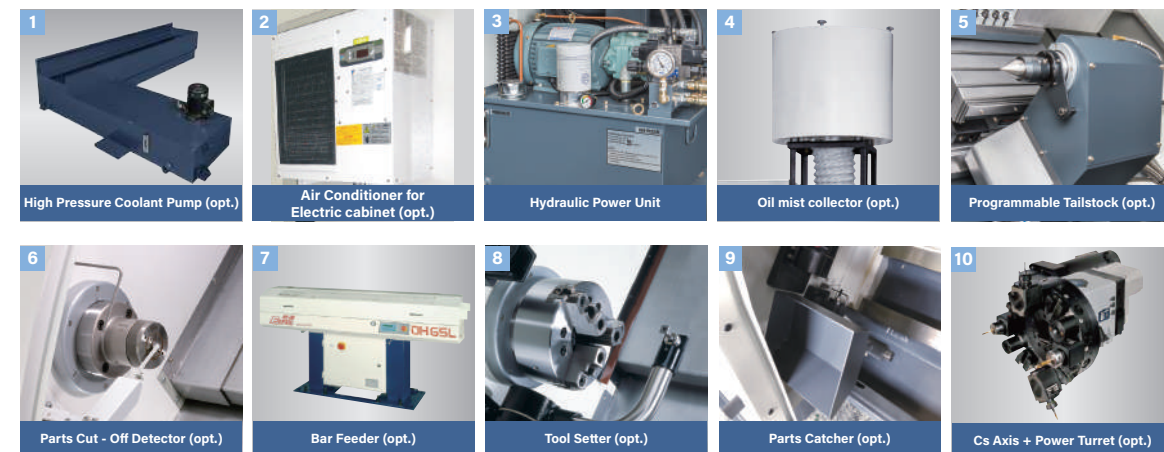

- » The TD axis is driven by a spindle motor or servo motor.
- » 0.001 degree indexing resolution makes it suitable for high precision contour / indexing control.
- » Using the hydraulic disk brake, it can achieve maximum stability in milling and contour machining.