

Frank CAM

Turning Modules

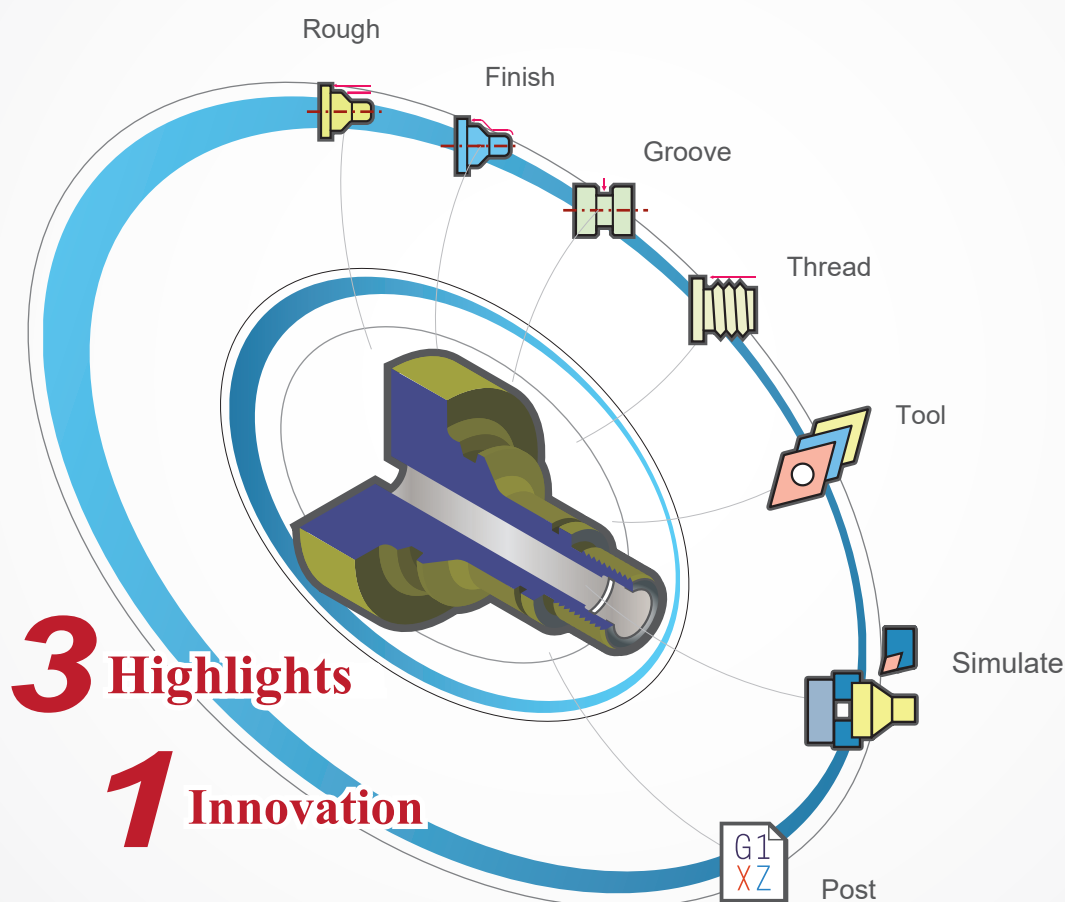

Visualized CAD/CAM system designed specifically for CNC turning professionals, reducing 80% of machining preparation time.

Guided instinctive operation: Follow the steps from up to down to finish the work. Greatly shortens learning time and enhances learning effectiveness. What a simple and thoughtful design!

Follow the icons
Up to down
5 steps only

Greatly reduce machining preparation time.

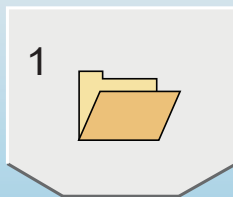

1

Thoughtful File Management & Material Settings Design

A. New Files, Open Files, Recent Files.
B. Material Dimensions Settings

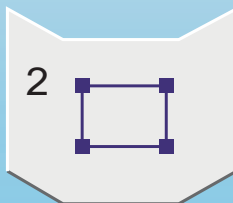

2

Intelligence CAD Drawing Method

Points, lines, arcs and more drawing methods. Whether it's tangent arcs or taper to arc, no shapes are too complicated to be easily handled.

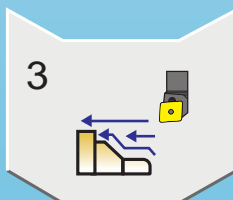

3

Detailed CAM Machining Settings

Guide users with selection icons to set roughing, finishing, grooving, threading, etc. Fine selections, detailed settings – Flawless!

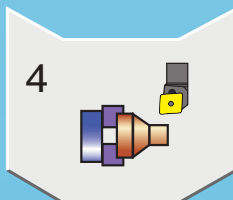

4

3D Animated Machining Simulation

Simulate actual machining in 3D motion to avoid interference and overcutting, verify tool paths to eliminate the uncertainty of collisions.

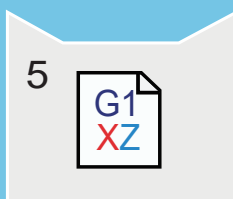

5

CNC Program Generation

Automatic NC code generation. Operation and settings as simple and quick as that. Elevating you to a CNC programming expert

80%

Highlight 1 Geometry Master

Specifically designed to work without computer graphic skills. No need to draw, just directly input coordinates to automatically turn into machining outline.

Get the hang of it easily even without computer graphic skills.

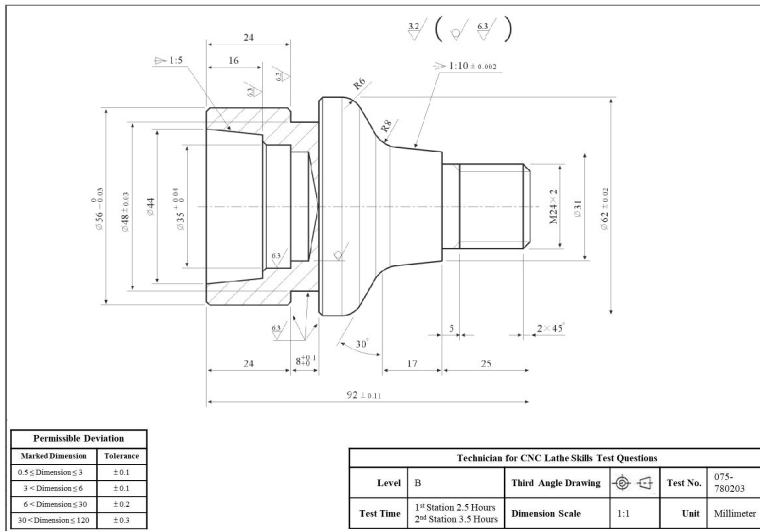

↓ Directly input coordinates and parameters following work drawing.

No.	Contour	X	Z	Radius	Angle	Corner	Chamfer
1	G01	0	-65				
2	G01		0				
3	G01	19.8					
4	G01	23.8	-2				
5	G01		-25				
6	G01	30.049					
7	G03	31.048	-25.475	0.5			
8	G01	32.265	-37.649				
9	G02	40.245	-44.178	8			
10	G01	56	-48.726				
11	G03	62	-53.922	6			

↓ Directly transform into outline.

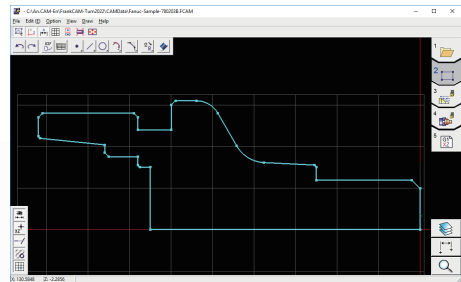

Highlight 2 CounterTurn

Abundant selection of figures for common parts. Create all kinds of parts without using codes. Directly select a figure, input basic dimensions to automatically calculate and create drawing.

↓ Input the known dimensions of the workpiece and the system automatically calculates the other dimensions immediately.

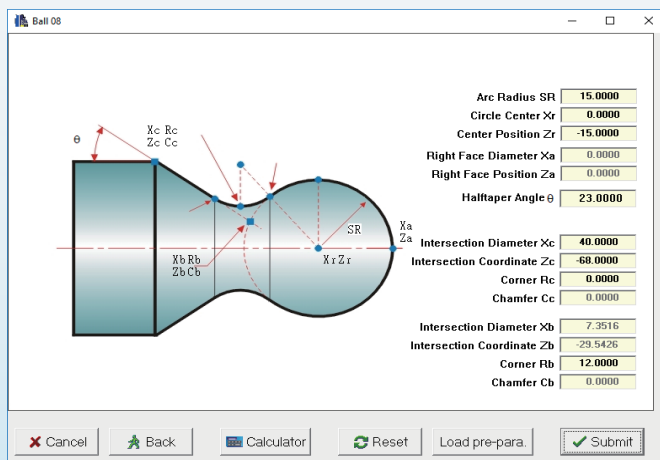

↓ Transform into outline.

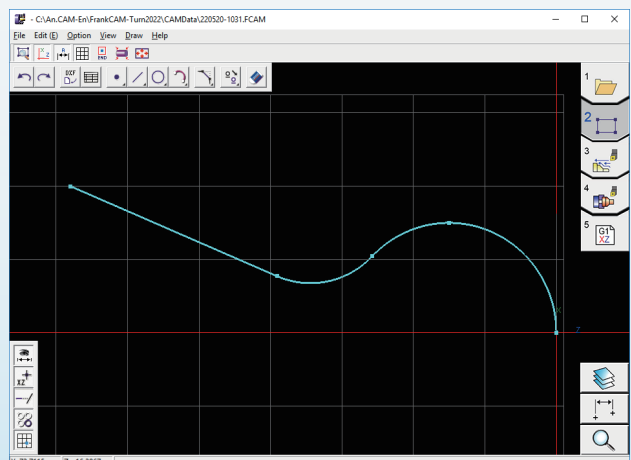

Highlight 3 Grooving Feed Order and Gradual Grooving Options

Utilize gradual same-depth grooving to prevent damaging tool while cutting deep into the workpiece. Coolant helps with cooling tool and removing chips smoothly. Greatly extending tool life up to three times.

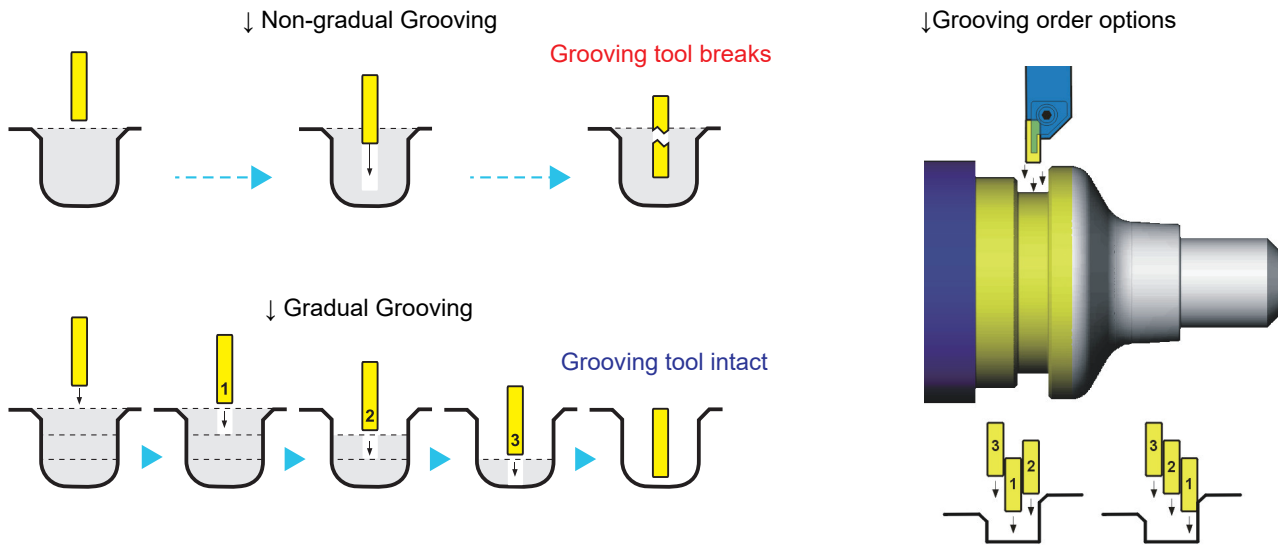

Item	Specifications
Drawing	<ul style="list-style-type: none"> ● Drawing Function <ul style="list-style-type: none"> (1)Point Function : Coordinate, Center, Intersection, Polar, Middle, on Arc (2)Line Function : Two Points Line, Angle, Angle & Tangent Arc, Through Point & Tangent Arc, Two Arc Tangent, Shift (3)Circle Function: Center & Radius, Two Points & Radius, Through Point &Tangent, Through Point & Tangent Circle, Tangent Two Lines, Tangent Line & Arc, Tangent Two Arcs, Begin Middle End, Two Points On Diameter, Center Point & On Circle, Center & Tangent, Wizard For Drawing Circle ● Cut and Corner: Auto Section, Section, Break, Cut, Corner-chamfer ● Modify Drawing: Workpiece Coordinate Zero Point Shift, Absolute Shift, Incremental Shift, Rotate, Mirror, Offset Contour, Scaling ● Layer Management: Add, Delete, Rename, Display ● Import DXF file made with any CAD systems. ● Measurement: Radius, Diameter, Length, Angle

Item	Specifications
Machining Process	<ul style="list-style-type: none"> ● Rough, Finish, Groove. Choose to cut along axial direction or radial direction. ● Set material dimensions directly. System automatically calculates complete cutting path. ● Set cutting times and depth for rough cutting. ● Supports G71 and G72 canned cycle function for rough cutting. ● Supports G74 and G75 canned cycle for grooving and drilling. ● Supports standard thread and taper thread - quick threading settings. ● Supports workpiece cut off settings and generates cutting off program. ● Supports G01, G74 and G83 drilling settings. ● Supports G32, G84 tapping settings. ● Offers approach and retract extension function, control path without additional drawing. ● Simple tool nose type options. Allows adjusting limit tool cutting angle. ● Insert angle, cutting angle, auto overcut judgment, arc overcut judgment. ● Grooving entry options: Gradual peck cut, middle to sides or single direction. ● No drag function to protect grooving tool with only force from one direction. ● Set tool change position to reduce the chance of collisions. ● Display all tool paths at once for comparison.
Machining Simulation	<ul style="list-style-type: none"> ● Tool motion and cutting process displayed in 3D simulation. ● Display tool, tool path, solid, or section during simulation. ● Simulate and display with actual machining. Adjustable simulation speed
Program Generation	<ul style="list-style-type: none"> ● Generate NC code directly in the system. Greatly reduce program generation and commissioning time. ● Simulate and display with actual machining. Adjustable simulation speed

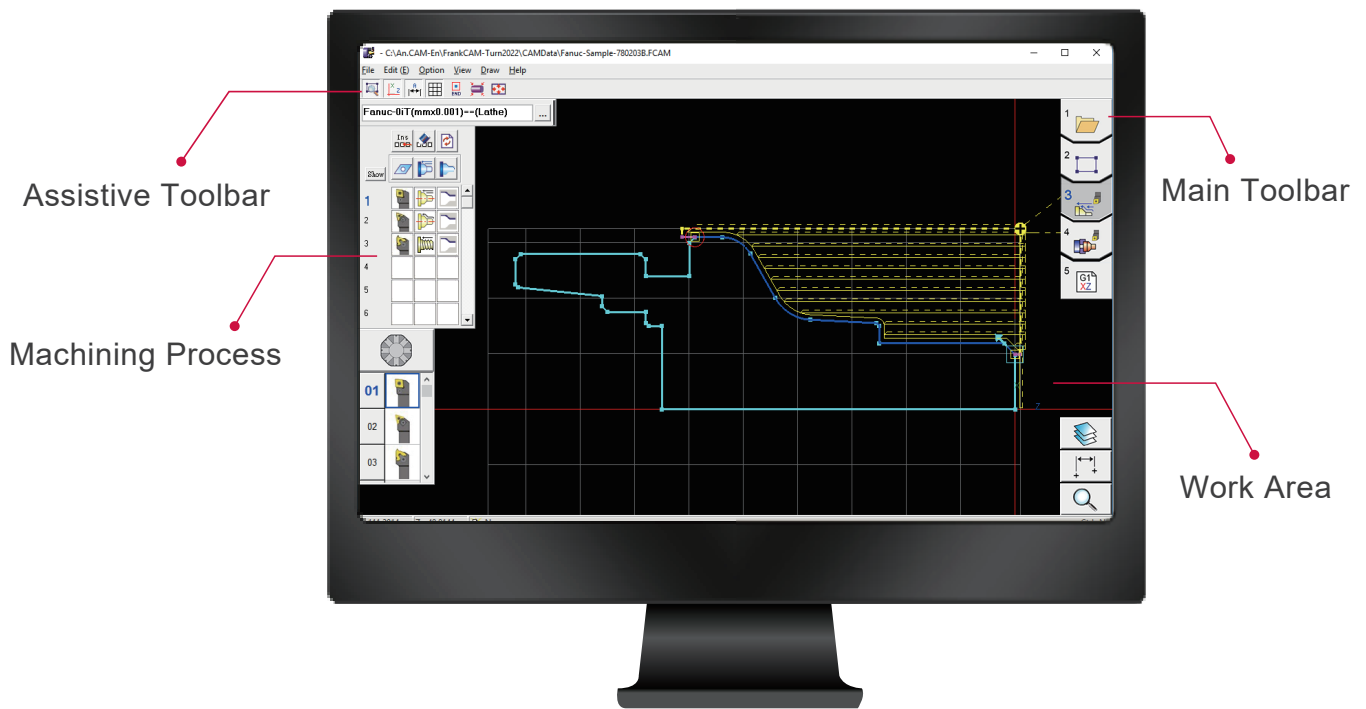

Highlight 1

Geometry Master

Get the hang of it easily even without computer graphic skills.

Highlight 2

CounterTurn

Directly select a figure, input basic dimensions to automatically calculate and draw geometric figures.

Highlight 3

Grooving Feed Order and Gradual Grooving Options

Utilize gradual same-depth grooving to prevent damaging tool while cutting deep into the workpiece. Greatly extending tool life up to three times.

Innovation 1

Guided Machining Steps Setting

Guided instinctive operation: Follow the steps from up to down to finish the work.



RenAn Information Technology Co., Ltd.

5F-3, No.1 Keji Road, Dali District, Taichung City 412025, Taiwan

+886(4)24918777
service@renan.com.tw
www.renan.com.tw



RenAn Website
Jun. 2022