

精搪孔刀桿

Cutting Bar

HBOR50

HBOR63

精搪孔刀座

Cutting Insert Holder

HBOR

精搪孔反搪刀座

Reverse Cutting Insert Holder

HBOR

下刀徑

$D_2 > e$

$D_2 \times 2 - D > HBOR_$

高速切削搪孔平衡系統

High Speed Cutting Boring System

HBOR25P

HBOR32P

HBOR40P

HBOR50P

HBOR63P

HBOR50P-BRM16

HBOR63P-BRM16

搪外徑系統-"正轉"切削

Outer Diameter Boring

System Cutting

HBOR63-BM16D

HBOR 極細微調精搪孔刀系統

Micro-Finishing Cutter Fine Boring System

在預設平衡狀態，在中心軸線裝搪刀，用
1放鬆LOCK螺絲，2微調搪孔尺寸，再鎖
緊LOCK螺絲，進行高速切削。

The boring tools are pre-balance.
1. Loosen locking bolt
2. Rotate the graduation to adjust the size,
then tighten the locking bolt.

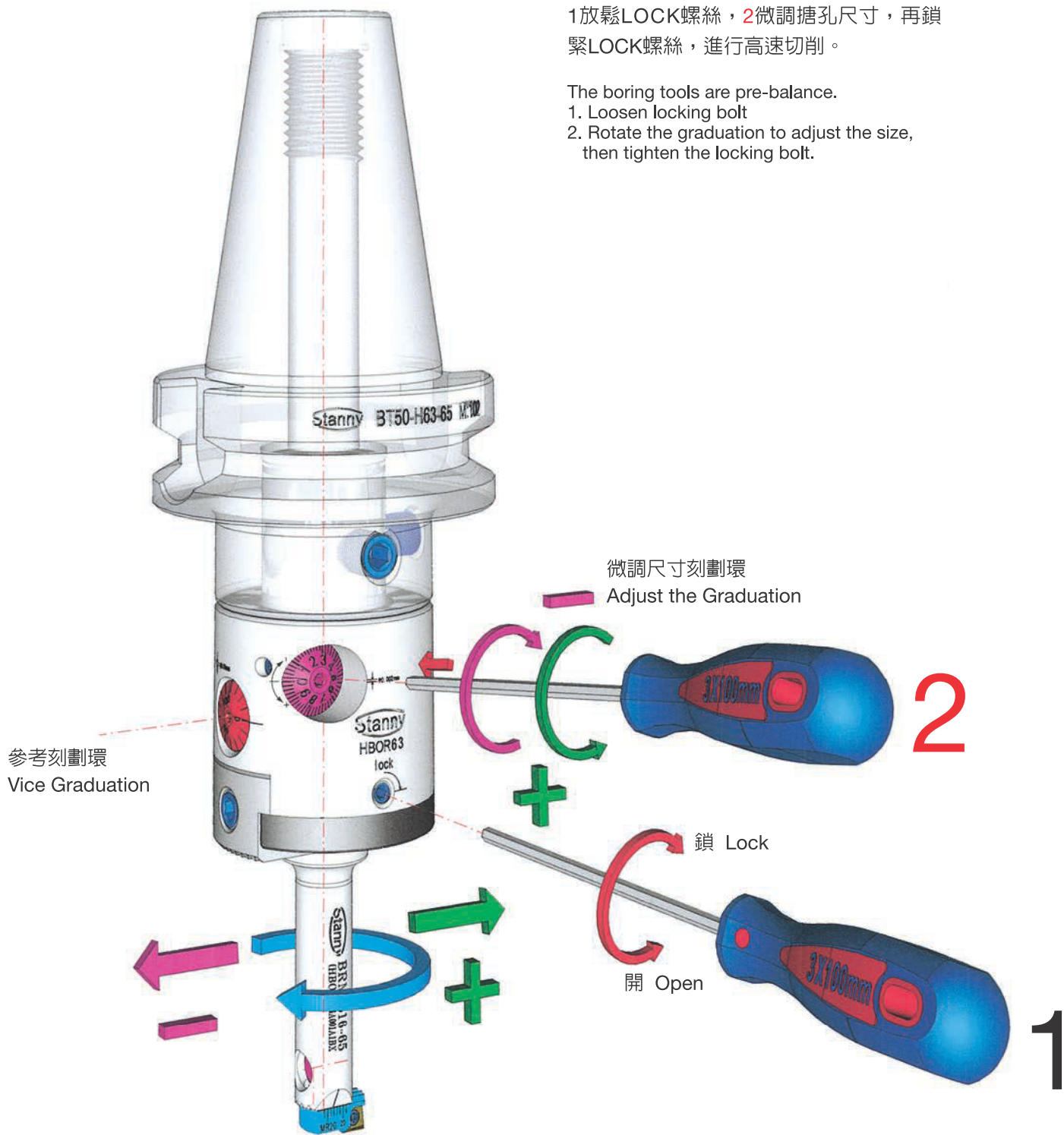

精搪孔刀本體 Body
精搪孔刀桿 Cutting Bar

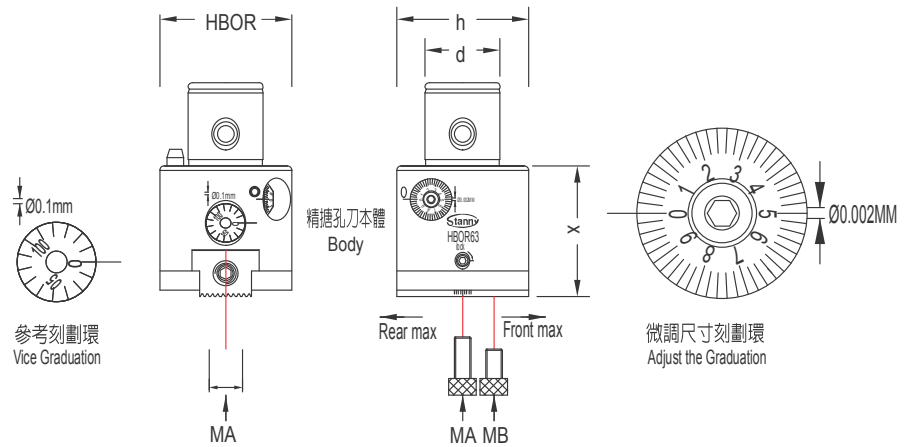

HBOR 極細微調精搪孔刀-精搪孔刀本體
Body for HBOR Micro-Finishing Cutter Fine Boring

| 訂貨編號 Order No. | 規格 Model | h | d | Front | Rear | X | MA Bolt | MB Bolt | 淨重 N.W. |
|-------------------|-------------|----|----|-------|------|----|---------|---------|------------|
| 51000025 | HBOR25 | 25 | 14 | 1 | 1 | 42 | M5×12 | | 0.15 |
| 51000032 | HBOR32 | 32 | 18 | 2 | 2 | 52 | M6×12 | | 0.35 |
| 51000040 | HBOR40 | 40 | 22 | 2 | 2 | 53 | M6×12 | | 0.50 |
| 51000050 | HBOR50 | 50 | 28 | 2 | 2 | 63 | φ 16 | | 0.92 |
| 51000063 | HBOR63 | 63 | 36 | 4 | 4 | 63 | φ 16 | M8×14 | 1.52 |

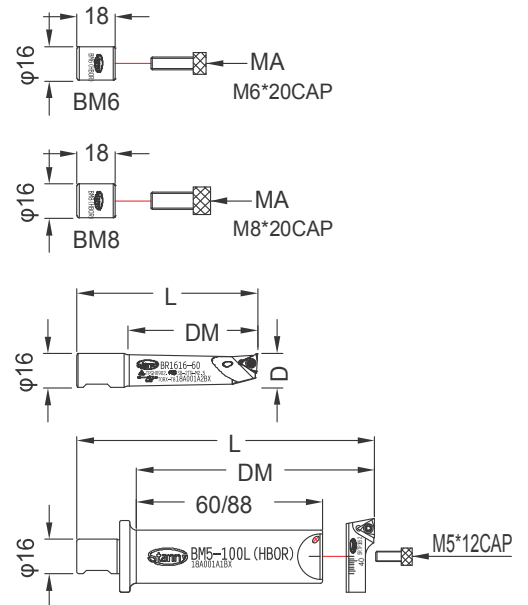

HBOR 極細微調精搪孔刀-精搪孔刀桿
Cutting Bar for HBOR50 and HBOR63 Micro-Finishing Cutter Fine Boring

| 訂貨編號 Order No. | 規格 Model | 範圍 D Boring Range øDMin-øDMax | 深度 Dimensions DM | 系統 System | 刀片 Insert | L | 螺絲 Bolt | 板手 Wrench | 淨重 N.W. |
|-------------------|-------------|-------------------------------------|---------------------------------------|------------------|------------------------------|-------|-------------------------|--------------|------------|
| 50160621 | BR1606-21 | 6-9 | 21 | HBOR50 HBOR63 | WBG0601..L | 54 | SB-1STR-M2 | T6 | 0.04 |
| 50160828 | BR1608-28 | 8-11 | 28 | | TBGT0601..L | 59 | | | 0.04 |
| 50161035 | BR1610-35 | 10-13 | 35 | | | 65 | | | 0.05 |
| 50161242 | BR1612-42 | 12-15 | 42 | | TPGH0902..L (TPGX0902..L) | 70 | SB-2TR-M2.5 (CS250T) | T8 | 0.06 |
| 50161450 | BR1614-50 | 14-17 | 50 | | | 77 | | | 0.07 |
| 50161660 | BR1616-60 | 16-20 | 60 | | | 85 | | | 0.09 |
| 50162065 | BR1620-65 | 20-24 | 65 | | | 88 | | | 0.11 |
| 50162468 | BR1624-68 | 24-28 | 68 | | 91 | 0.12 | | | |
| 50162505 | BM5 | | 60 + SRTP2938 or SRTP3652 or SRTP4468 | | | 80+ | M5×12 | ◇ 4 | 0.25 |
| 50162510 | BM5-100L | | 88 + SRTP2938 or SRTP3652 or SRTP4468 | | | 116+ | | | 0.40 |
| 50501608 | BM8 | | +SRTP5790 or SRTP70110 or SRTP110150 | | | M8×20 | ◇ 6 | 0.03 | |
| 50501606 | BM6 | | +SRTP4468 or SRTP6690 or SRTP88112 | | | M6×20 | ◇ 5 | 0.03 | |

PS.(CS系列螺絲, 請訂貨時另外告知)
PS.Order bolt CS series, please advise in advance.

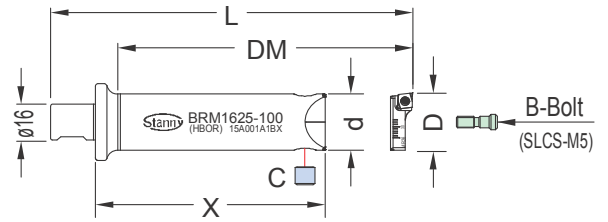

HBOR 極細微調精搪孔刀-接桿
Shank for HBOR50(P) \ HBOR63(P) Micro-Finishing Cutter Fine Boring

| 訂貨編號 Order No. | 規格 Model | X | 深度 DM | L | d | C導程螺帽 C-NUT | B螺絲 B-Bolt | 板手 Wrench | 淨重 N.W. |
|-------------------|-------------|-----|----------|-----|----|----------------|---------------|--------------|------------|
| 50171004 | BRM1610-40 | 45 | 41 | 71 | 10 | NUT6 | SLCS-M3 | T8 | 0.07 |
| 50171205 | BRM1612-50 | 54 | 51 | 81 | 12 | NUT7 | SLCS-M4 | T15 | 0.09 |
| 50171405 | BRM1614-55 | 59 | 56 | 86 | 14 | | | | 0.11 |
| 50171504 | BRM1615-40 | 42 | 41 | 71 | 15 | | | | 0.10 |
| 50171506 | BRM1615-65 | 67 | 66 | 96 | 15 | | | | 0.13 |
| 50171606 | BRM1616-65 | 67 | 66 | 96 | 16 | NUT9 | SLCS-M5 | T25 | 0.14 |
| 50171905 | BRM1619-50 | 52 | 51 | 81 | 19 | | | | 0.14 |
| 50171908 | BRM1619-80 | 82 | 81 | 111 | 19 | | | | 0.20 |
| 50172008 | BRM1620-80 | 82 | 81 | 111 | 20 | | | | 0.22 |
| 50172406 | BRM1624-63 | 65 | 64 | 94 | 24 | | | | 0.26 |
| 50172410 | BRM1624-100 | 102 | 101 | 131 | 24 | 0.38 | | | |
| 50172510 | BRM1625-100 | 102 | 101 | 131 | 25 | 0.41 | | | |

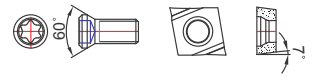
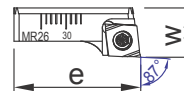

HBOR 極細微調精搪孔刀-MR精搪孔刀座
Cutting Insert Holder

| 訂貨編號 Order No. | 規格 Model | 範圍 D Boring Range øDMin-øDMax | W | e | 接桿 Shank | 刀片 Insert | 螺絲 Bolt | 板手 Wrench | 淨重 N.W. |
|-------------------|-------------|-------------------------------------|------|-------------|---------------------------|--------------|----------------|--------------|------------|
| 50061114 | MR11 | 11-14 | 6 | 10.6 | BRM1610-40 | CCGT0301..L | SB-1630TR-M1.6 | T6 | 0.002 |
| 50061317 | MR13 | 13-17 | 7 | 12.6 | BRM1612-50 | CCGT0401..L | SB-2040TR-M2 | | 0.003 |
| 50061522 | MR15 | 15-22 | 7 | 14.4 | BRM1614-55 | CCGT0602..L | TS25-M2.5 | | 0.003 |
| 50061623 | MR16 | 16-23 | 9 | 15.4 | BRM1615-40 BRM1615-65 | | | T8 | 0.005 |
| 50061723 | MR17 | 17-23 | | 16.6 | BRM1616-65 | | | | 0.005 |
| 50062026 | MR20 | 20-30 | | 19.4 | BRM1619-50 BRM1619-80 | | | | 0.006 |
| 50062329 | MR23 | 23-33 | | 22.4 | BRM1620-80 | 0.008 | | | |
| 50062632 | MR26 | 26-40 | | 25.4 | BRM1624-63 BRM1624-100 | 0.009 | | | |
| 50062943 | MR29 | 29-43 | 28.4 | BRM1625-100 | 0.009 | | | | |

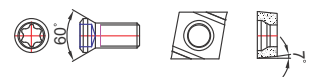
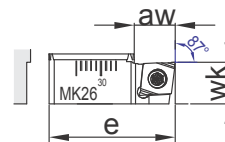

HBOR 極細微調精搪孔刀-MK精搪孔反搪刀座
Reverse Cutting Insert Holder

| 訂貨編號 Order No. | 規格 Model | 範圍 D Boring Range øDMin-øDMax | aw | wk | e | 接桿 Shank | 刀片 Insert | 螺絲 Bolt | 板手 Wrench | 淨重 NW. |
|-------------------|-------------|-------------------------------------|-----|------|-------------|---------------------------|--------------|----------------|--------------|-----------|
| 50051114 | MK11 | 11-14 | 2.5 | 6 | 10.7 | BRM1610-40 | CCGT0301..R | SB-1630TR-M1.6 | T6 | 0.002 |
| 50051317 | MK13 | 13-17 | 2.8 | 7 | 12.6 | BRM1612-50 | CCGT0401..R | SB-2040TR-M2 | | 0.003 |
| 50051522 | MK15 | 15-22 | 4.4 | 7 | 14.4 | BRM1614-55 | CCGT0602..R | TS25-M2.5 | | 0.004 |
| 50051623 | MK16 | 16-23 | 4.5 | 9 | 15.4 | BRM1615-40 BRM1615-65 | | | T8 | 0.005 |
| 50051723 | MK17 | 17-23 | 4 | | 16.6 | BRM1616-65 | | | | 0.006 |
| 50052026 | MK20 | 20-30 | 5.4 | | 19.4 | BRM1619-50 BRM1619-80 | | | | 0.007 |
| 50052329 | MK23 | 23-33 | 6.6 | | 22.4 | BRM1620-80 | 0.009 | | | |
| 50052632 | MK26 | 26-40 | 8.1 | | 25.4 | BRM1624-63 BRM1624-100 | 0.011 | | | |
| 50052943 | MK29 | 29-43 | 9 | 28.4 | BRM1625-100 | 0.014 | | | | |

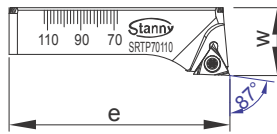

SB系列螺絲(Bolt)

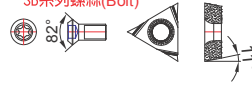

CS系列螺絲(Bolt)

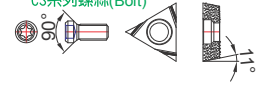

HBOR 極細微調精搪孔刀-精搪孔刀座 Cutting Insert Holder for HBOR Micro-Finishing Cutter Fine Boring

| 訂貨編號 Order No. | 規格 Model | 範圍 D Boring Range øDMin-øDMax | W | e | 系統 System | MA | 刀片 Insert | 螺絲 Bolt | 板手 Wrench | 淨重 N.W. |
|-------------------|-------------|-------------------------------------|----|-----|------------------|-----|------------------------------|-------------------------|--------------|------------|
| 50252938 | SRTP2938 | 29-38 | 11 | 28 | HBOR25 | M5 | TPGH0902..L (TPGX0902..L) | SB-2TR-M2.5 (CS250T) | T8 | 0.01 |
| 50323652 | SRTP3652 | 36-52 | 13 | 35 | HBOR32 | M6 | | | | 0.02 |
| 50404468 | SRTP4468 | 44-68 | 13 | 43 | HBOR40 | M6 | | | | 0.03 |
| 50406690 | SRTP6690 | 66-90 | 13 | 54 | HBOR50 HBOR63 | BM6 | | | | 0.04 |
| 50408811 | SRTP88112 | 88-112 | 13 | 65 | HBOR50 HBOR63 | BM6 | | | | 0.05 |
| 50505790 | SRTP5790 | 57-90 | 20 | 54 | HBOR50 | BM8 | TPGH1103..L (TPGX1103..L) | SB-3TR-M3 (CS300T) | T8 | 0.10 |
| 50637011 | SRTP70110 | 70-110 | 20 | 67 | HBOR63 | BM8 | | | | 0.10 |
| 50637115 | SRTP110150 | 110-150 | 20 | 107 | HBOR63 | BM8 | | | | 0.21 |

PS.(CS系列螺絲，請訂貨時另外告知) PS.Order bolt CS series, please advise in advance.

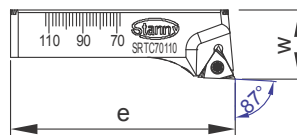

TS系列螺絲

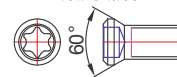

HBOR 極細微調精搪孔刀-精搪孔刀座 Cutting Insert Holder for HBOR Micro-Finishing Cutter Fine Boring

| 訂貨編號 Order No. | 規格 Model | 範圍 D Boring Range øDMin-øDMax | W | e | 系統 System | MA | 刀片 Insert | 螺絲 Bolt | 板手 Wrench | 淨重 N.W. |
|-------------------|-------------|-------------------------------------|----|-----|--------------|-----|--------------|------------|--------------|------------|
| 50323652TC | SRTC3652 | 36-52 | 15 | 35 | HBOR32 | M6 | TCGT1102..L | TS25-M2.5 | T8 | 0.02 |
| 50404468TC | SRTC4468 | 44-68 | 15 | 43 | HBOR40 | M6 | | | | 0.03 |
| 50505790TC | SRTC5790 | 57-90 | 20 | 54 | HBOR50 | BM8 | | | | 0.09 |
| 50637011TC | SRTC70110 | 70-110 | 20 | 67 | HBOR63 | BM8 | | | | 0.10 |
| 50637115TC | SRTC110150 | 110-150 | 20 | 107 | HBOR63 | BM8 | | | | 0.20 |

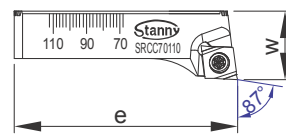

TS系列螺絲(Bolt)

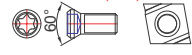

HBOR 極細微調精搪孔刀-菱形精搪孔刀座 Rhombus Cutting Insert Holder for HBOR Micro-Finishing Cutter Fine Boring

| 訂貨編號 Order No. | 規格 Model | 範圍 D Boring Range øDMin-øDMax | W | e | 系統 System | MA | 刀片 Insert | 螺絲 Bolt | 板手 Wrench | 淨重 N.W. |
|-------------------|-------------|-------------------------------------|----|-----|------------------|-----|--------------|------------|--------------|------------|
| 50252938CC | SRCC2938 | 29-38 | 11 | 26 | HBOR25 | M5 | CCGT0602..L | TS25-M2.5 | T8 | 0.01 |
| 50323652CC | SRCC3652 | 36-52 | 13 | 35 | HBOR32 | M6 | | | | 0.02 |
| 50404468CC | SRCC4468 | 44-68 | 13 | 43 | HBOR40 | M6 | | | | 0.03 |
| 50406690CC | SRCC6690 | 66-90 | 13 | 54 | HBOR50 HBOR63 | BM6 | | | | 0.04 |
| 50408811CC | SRCC88112 | 88-112 | 13 | 65 | HBOR50 HBOR63 | BM6 | | | | 0.05 |
| 50505790CC | SRCC5790 | 57-90 | 20 | 54 | HBOR50 | BM8 | CCGT09T3..L | TS4-M4 | T15 | 0.09 |
| 50637011CC | SRCC70110 | 70-110 | 20 | 67 | HBOR63 | BM8 | | | | 0.10 |
| 50637115CC | SRCC110150 | 110-150 | 20 | 107 | HBOR63 | BM8 | | | | 0.20 |
| 50637159CC | SRCC150190 | 150-190 | 22 | 149 | HBOR63 | BM8 | | | | 0.36 |
| 50637193CC | SRCC190230 | 190-230 | 22 | 189 | HBOR63 | BM8 | | | | 0.48 |

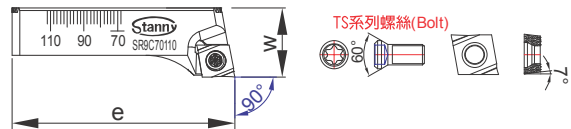

HBOR 極細微調精搪孔刀-90°菱形精搪孔刀座
90° Rhombus Cutting Insert Holder for HBOR Micro-Finishing Cutter Fine Boring

| 訂貨編號 Order No. | 規格 Model | 範圍 D Boring Range øDMin-øDMax | W | e | 系統 System | MA | 刀片 Insert | 螺絲 Bolt | 板手 Wrench | 淨重 N.W. |
|-------------------|-------------|-------------------------------------|----|-----|--------------|-----|--------------|------------|--------------|------------|
| 50252938C9 | SR9C2938 | 29-38 | 11 | 26 | HBOR25 | M5 | | | | 0.01 |
| 50323652C9 | SR9C3652 | 36-52 | 13 | 35 | HBOR32 | M6 | CCGT0602..L | TS25-M2.5 | T8 | 0.02 |
| 50404468C9 | SR9C4468 | 44-68 | 13 | 43 | HBOR40 | M6 | | | | 0.03 |
| 50505790C9 | SR9C5790 | 57-90 | 20 | 54 | HBOR50 | BM8 | | | | 0.09 |
| 50637011C9 | SR9C70110 | 70-110 | 20 | 67 | HBOR63 | BM8 | CCGT09T3..L | TS4-M4 | T15 | 0.10 |
| 50637115C9 | SR9C110150 | 110-150 | 20 | 107 | HBOR63 | BM8 | | | | 0.20 |

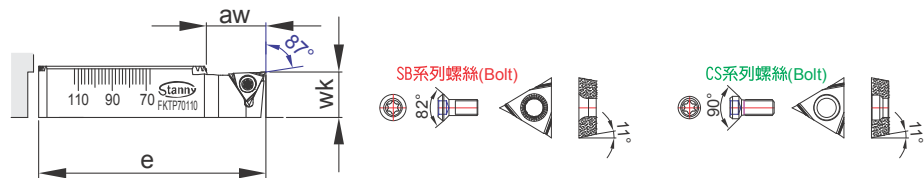

HBOR 極細微調精搪孔刀-精搪孔反搪刀座
Reverse Cutting Insert Holder for HBOR Micro-Finishing Cutter Fine Boring

| 訂貨編號 Order No. | 規格 Model | 範圍 D Boring Range øDMin-øDMax | aw | wk | e | 系統 System | 刀片 Insert | 螺絲 Bolt | 板手 Wrench | 淨重 N.W. |
|-------------------|-------------|-------------------------------------|----|----|-----|--------------|------------------------------|-------------------------|--------------|------------|
| 50252938K | FKTP2938 | 29-38 | 6 | 11 | 27 | HBOR25 | | | | 0.01 |
| 50323652K | FKTP3652 | 36-52 | 10 | 11 | 35 | HBOR32 | TPGH0902..R (TPGX0902..R) | SB-2TR-M2.5 (CS250T) | T8 | 0.02 |
| 50404468K | FKTP4468 | 44-68 | 12 | 11 | 43 | HBOR40 | | | | 0.03 |
| 50505790K | FKTP5790 | 57-90 | 14 | 15 | 54 | HBOR50 | | | | 0.10 |
| 50637011K | FKTP70110 | 70-110 | 16 | 15 | 66 | HBOR63 | TPGH1103..R (TPGX1103..R) | SB-3TR-M3 (CS300T) | | 0.10 |
| 50637115K | FKTP110150 | 110-150 | 25 | 15 | 106 | | | | | 0.21 |

PS.(CS系列螺絲, 請訂貨時另外告知) PS.Order bolt CS series, please advise in advance.

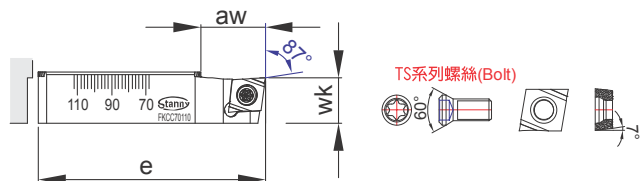

HBOR 極細微調精搪孔刀-菱形精搪孔反搪刀座
Rhombus Reverse Cutting Insert Holder for HBOR Micro-Finishing Cutter Fine Boring

| 訂貨編號 Order No. | 規格 Model | 範圍 D Boring Range øDMin-øDMax | aw | wk | e | 系統 System | 刀片 Insert | 螺絲 Bolt | 板手 Wrench | 淨重 N.W. |
|-------------------|-------------|-------------------------------------|------|----|-----|--------------|--------------|------------|--------------|------------|
| 50252938KC | FKCC2938 | 29-38 | 7 | 11 | 26 | HBOR25 | | | | 0.01 |
| 50323652KC | FKCC3652 | 36-52 | 10 | 11 | 35 | HBOR32 | CCGT0602..R | TS25-M2.5 | T8 | 0.02 |
| 50404468KC | FKCC4468 | 44-68 | 13 | 11 | 43 | HBOR40 | | | | 0.03 |
| 50505790KC | FKCC5790 | 57-90 | 14 | 15 | 54 | HBOR50 | | | | 0.09 |
| 50637011KC | FKCC70110 | 70-110 | 16 | 15 | 67 | HBOR63 | CCGT09T3..R | TS4-M4 | T15 | 0.10 |
| 50637115KC | FKCC110150 | 110-150 | 28 | 15 | 107 | | | | | 0.20 |
| 50637159KC | FKCC150190 | 150-190 | 31.5 | 20 | 105 | | | | | 0.24 |
| 50637193KC | FKCC190230 | 190-230 | 32 | 20 | 125 | | | | | 0.31 |

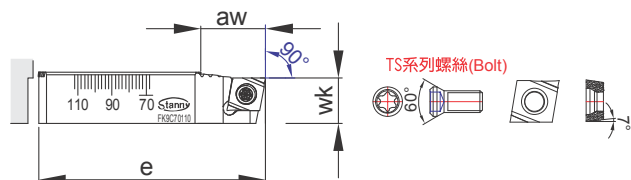

HBOR 極細微調精搪孔刀-90°菱形精搪孔反搪刀座
90° Rhombus Reverse Cutting Insert Holder for HBOR Micro-Finishing Cutter Fine Boring

| 訂貨編號 Order No. | 規格 Model | 範圍 D Boring Range øDMin-øDMax | aw | wk | e | 系統 System | 刀片 Insert | 螺絲 Bolt | 板手 Wrench | 淨重 N.W. |
|-------------------|-------------|-------------------------------------|----|----|-----|--------------|--------------|------------|--------------|------------|
| 50252938K9 | FK9C2938 | 29-38 | 7 | 11 | 26 | HBOR25 | | | | 0.01 |
| 50323652K9 | FK9C3652 | 36-52 | 10 | 11 | 35 | HBOR32 | CCGT0602..R | TS25-M2.5 | T8 | 0.02 |
| 50404468K9 | FK9C4468 | 44-68 | 13 | 11 | 43 | HBOR40 | | | | 0.03 |
| 50505790K9 | FK9C5790 | 57-90 | 14 | 15 | 54 | HBOR50 | | | | 0.09 |
| 50637011K9 | FK9C70110 | 70-110 | 16 | 15 | 67 | HBOR63 | CCGT09T3..R | TS4-M4 | T15 | 0.10 |
| 50637115K9 | FK9C110150 | 110-150 | 28 | 15 | 107 | | | | | 0.20 |

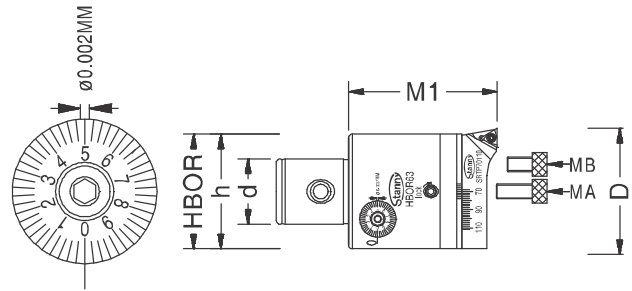

HBOR 極細微調精搪孔刀
HBOR Micro-Finishing Cutter Fine Boring Head

| 訂貨編號 Order No. | 規格 Model | 範圍 D Boring Range $\varnothing D_{Min}-\varnothing D_{Max}$ | M1 | h | 精搪孔系統組合 Micro-Finishing Cutter Fine Boring and Cutting System | | | | 淨重 N.W. |
|-------------------|-------------|---|----|----|--|------------|------------|--------------------------------|------------|
| | | | | | 精搪孔刀本體 Boring Head | MA Bolt | MB Bolt | 精搪孔刀座 Cutting Insert Holder | |
| 52290000 | HBOR25 M | 29-38 | 50 | 25 | HBOR25 | M5×12 | | SRTP2938 | 0.16 |
| 53360000 | HBOR32 M | 36-52 | 63 | 32 | HBOR32 | M6×12 | | SRTP3652 | 0.37 |
| 54440000 | HBOR40 M | 44-68 | 63 | 40 | HBOR40 | M6×12 | | SRTP4468 | 0.53 |
| 55570000 | HBOR50 BM | 57-90 | 80 | 50 | HBOR50 | BM8×20 | | SRTP5790 | 1.05 |
| 56700000 | HBOR63 BM | 70-110 | 80 | 63 | HBOR63 | BM8×20 | M8×14 | SRTP70110 | 1.65 |
| 56710000 | HBOR63 BM | 110-150 | 80 | 63 | HBOR63 | BM8×20 | M8×14 | SRTP110150 | 1.76 |

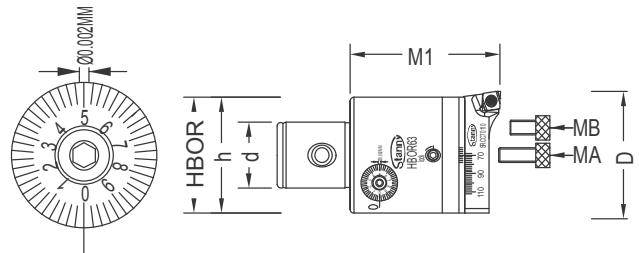

HBOR 極細微調精搪孔刀—菱形
HBOR Micro-Finishing Cutter for Rhombus Fine Boring Head

| 訂貨編號 Order No. | 規格 Model | 範圍 D Boring Range $\varnothing D_{Min}-\varnothing D_{Max}$ | M1 | h | 精搪孔系統組合 Micro-Finishing Cutter Fine Boring and Cutting System | | | | 淨重 N.W. |
|-------------------|-------------|---|----|----|--|------------|------------|--|------------|
| | | | | | 精搪孔刀本體 Boring Head | MA Bolt | MB Bolt | 菱形精搪孔刀座 Rhombus Cutting Insert Holder | |
| 52290000CC | HBOR25 MCC | 29-38 | 50 | 25 | HBOR25 | M5×12 | | SRCC2938 | 0.16 |
| 53360000CC | HBOR32 MCC | 36-52 | 63 | 32 | HBOR32 | M6×12 | | SRCC3652 | 0.37 |
| 54440000CC | HBOR40 MCC | 44-68 | 63 | 40 | HBOR40 | M6×12 | | SRCC4468 | 0.53 |
| 55570000CC | HBOR50 BMCC | 57-90 | 80 | 50 | HBOR50 | BM8×20 | | SRCC5790 | 1.06 |
| 56700000CC | HBOR63 BMCC | 70-110 | 80 | 63 | HBOR63 | BM8×20 | M8×14 | SRCC70110 | 1.65 |
| 56710000CC | HBOR63 BMCC | 110-150 | 80 | 63 | HBOR63 | BM8×20 | M8×14 | SRCC110150 | 1.75 |
| 56720000CC | HBOR63 BMCC | 150-190 | 82 | 63 | HBOR63 | BM8×20 | M8×14 | SRCC150190 | 1.91 |
| 56730000CC | HBOR63 BMCC | 190-230 | 82 | 63 | HBOR63 | BM8×20 | M8×14 | SRCC190230 | 2.03 |

HBOR 極細微調精搪孔刀—90°菱形
HBOR Micro-Finishing Cutter for 90° Rhombus Fine Boring Head

| | | | | | | | | | |
|------------|-------------|---------|----|----|--------|--------|-------|------------|------|
| 52290000C9 | HBOR25 MC9 | 29-38 | 50 | 25 | HBOR25 | M5×12 | | SR9C2938 | 0.16 |
| 53360000C9 | HBOR32 MC9 | 36-52 | 63 | 32 | HBOR32 | M6×12 | | SR9C3652 | 0.37 |
| 54440000C9 | HBOR40 MC9 | 44-68 | 63 | 40 | HBOR40 | M6×12 | | SR9C4468 | 0.53 |
| 55570000C9 | HBOR50 BMC9 | 57-90 | 80 | 50 | HBOR50 | BM8×20 | | SR9C5790 | 1.06 |
| 56700000C9 | HBOR63 BMC9 | 70-110 | 80 | 63 | HBOR63 | BM8×20 | M8×14 | SR9C70110 | 1.65 |
| 56710000C9 | HBOR63 BMC9 | 110-150 | 80 | 63 | HBOR63 | BM8×20 | M8×14 | SR9C110150 | 1.75 |

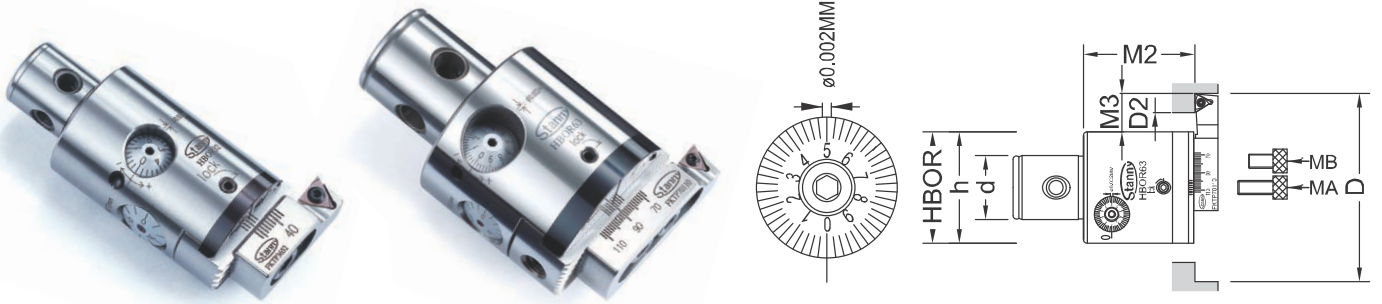

$D_2 > e$
下刀徑: $D_2 \times 2 - D > \text{HBOR}$

HBOR 極細微調精搪孔刀—反搪 HBOR Micro-Finishing Cutter for Reverse Fine Boring Head

| 訂貨編號 Order No. | 規格 Model | 範圍 D Boring Range $\phi D_{\text{Min}} - \phi D_{\text{Max}}$ | M3 | M2 | h | 精搪孔反搪系統組合 Micro-Finishing Cutter for Reverse Fine Boring and Cutting System | | | | 淨重 N.W. |
|-------------------|-------------|---|-------|------|----|--|------------|------------|--|------------|
| | | | | | | 精搪孔刀本體 Boring Head | MA Bolt | MB Bolt | 精搪孔反搪刀座 Reverse Cutting Insert Holder | |
| 52290000K | HBOR25 MK | 29-38 | 2-6 | 42 | 25 | HBOR25 | M5×12 | | FKTP2938 | 0.16 |
| 53360000K | HBOR32 MK | 36-52 | 2-10 | 52.5 | 32 | HBOR32 | M6×12 | | FKTP3652 | 0.37 |
| 54440000K | HBOR40 MK | 44-68 | 2-14 | 53 | 40 | HBOR40 | M6×12 | | FKTP4468 | 0.53 |
| 55570000K | HBOR50 BMK | 57-90 | 3-20 | 64.5 | 50 | HBOR50 | BM8×20 | | FKTP5790 | 1.05 |
| 56700000K | HBOR63 BMK | 70-110 | 3-23 | 62.5 | 63 | HBOR63 | BM8×20 | M8×14 | FKTP70110 | 1.65 |
| 56710000K | HBOR63 BMK | 110-150 | 23-43 | 62.5 | 63 | HBOR63 | BM8×20 | M8×14 | FKTP110150 | 1.76 |

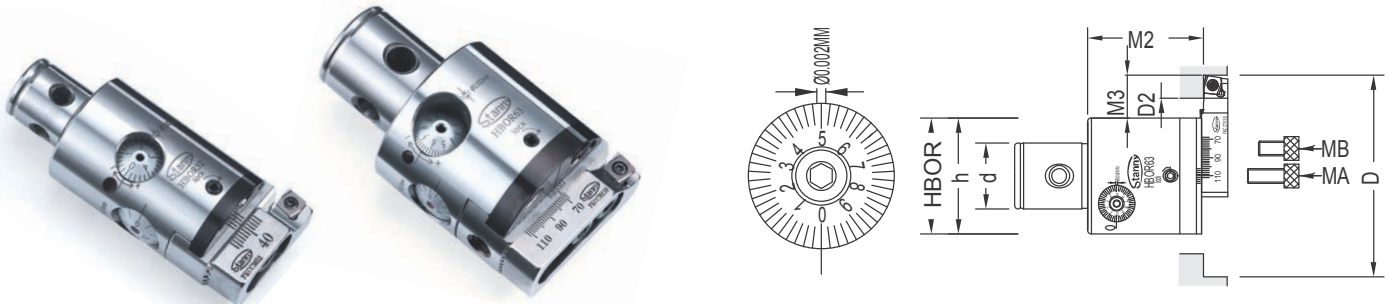

$D_2 > e$
下刀徑: $D_2 \times 2 - D > \text{HBOR}$

HBOR 極細微調精搪孔刀—菱形反搪 HBOR Micro-Finishing Cutter for Rhombus Reverse Fine Boring Head

| 訂貨編號 Order No. | 規格 Model | 範圍 D Boring Range $\phi D_{\text{Min}} - \phi D_{\text{Max}}$ | M3 | M2 | h | 精搪孔反搪系統組合 Micro-Finishing Cutter for Reverse Fine Boring and Cutting System | | | | 淨重 N.W. |
|-------------------|-------------|---|-------|------|----|--|------------|------------|--|------------|
| | | | | | | 精搪孔刀本體 Boring Head | MA Bolt | MB Bolt | 菱形精搪孔反搪刀座 Rhombus Reverse Cutting Insert Holder | |
| 52290000KC | HBOR25 MKC | 29-38 | 2-6 | 42 | 25 | HBOR25 | M5×12 | | FKCC2938 | 0.16 |
| 53360000KC | HBOR32 MKC | 36-52 | 2-10 | 52.5 | 32 | HBOR32 | M6×12 | | FKCC3652 | 0.37 |
| 54440000KC | HBOR40 MKC | 44-68 | 2-14 | 53 | 40 | HBOR40 | M6×12 | | FKCC4468 | 0.53 |
| 55570000KC | HBOR50 BMKC | 57-90 | 3-20 | 64.5 | 50 | HBOR50 | BM8×20 | | FKCC5790 | 1.06 |
| 56700000KC | HBOR63 BMKC | 70-110 | 3-23 | 62.5 | 63 | HBOR63 | BM8×20 | M8×14 | FKCC70110 | 1.65 |
| 56710000KC | HBOR63 BMKC | 110-150 | 23-43 | 62.5 | 63 | HBOR63 | BM8×20 | M8×14 | FKCC110150 | 1.75 |
| 56720000KC | HBOR63 BMKC | 150-190 | 43-63 | 62.5 | 63 | HBOR63 | BM8×20 | M8×14 | FKCC150190 | 1.79 |
| 56730000KC | HBOR63 BMKC | 190-230 | 63-83 | 62.5 | 63 | HBOR63 | BM8×20 | M8×14 | FKCC190230 | 1.86 |

HBOR 極細微調精搪孔刀—90°菱形反搪 HBOR Micro-Finishing Cutter for 90° Rhombus Reverse Fine Boring Head

| | | | | | | | | | | |
|------------|-------------|---------|-------|------|----|--------|--------|-------|------------|------|
| 52290000K9 | HBOR25 MK9 | 29-38 | 2-6 | 42 | 25 | HBOR25 | M5×12 | | FK9C2938 | 0.16 |
| 53360000K9 | HBOR32 MK9 | 36-52 | 2-10 | 52.5 | 32 | HBOR32 | M6×12 | | FK9C3652 | 0.37 |
| 54440000K9 | HBOR40 MK9 | 44-68 | 2-14 | 53 | 40 | HBOR40 | M6×12 | | FK9C4468 | 0.53 |
| 55570000K9 | HBOR50 BMK9 | 57-90 | 3-20 | 64.5 | 50 | HBOR50 | BM8×20 | | FK9C5790 | 1.06 |
| 56700000K9 | HBOR63 BMK9 | 70-110 | 3-23 | 62.5 | 63 | HBOR63 | BM8×20 | M8×14 | FK9C70110 | 1.65 |
| 56710000K9 | HBOR63 BMK9 | 110-150 | 23-43 | 62.5 | 63 | HBOR63 | BM8×20 | M8×14 | FK9C110150 | 1.75 |

搪孔刀柄、精搪孔刀本體、精搪孔刀座 Taper Shank, Body and Cutting Insert Holder



整支 SET

MAS403 BT-HBOR 極細微調精搪孔刀

MAS403 BT and HBOR Micro-Finishing Cutter Fine Boring Head

| 訂貨編號 Order No. | 規格 Model | 範圍 D Boring Range øDMin-øDMax | M | L | 精搪孔系統組合 Micro-Finishing Cutter Fine Boring System | | | | 淨重 N.W. |
|-------------------|-----------------|-------------------------------------|-----|-----|--|-----------------------|------------------|-----------------------------------|------------|
| | | | | | 搪孔刀柄 Taper Shank | 精搪孔刀本體 Boring Head | 連接器 Connector | 精搪孔刀座 Cutting Insert Holder | |
| 52291306 | BT30-HBOR25-60 | M 29-38 | 60 | 85 | BT30-H25-35 | HBOR25 | M5 | SRTP2938 | 0.56 |
| 52291307 | BT30-HBOR25-75 | M 29-38 | 75 | 105 | BT30-H25-55 | HBOR25 | M5 | SRTP2938 | 0.62 |
| 53361307 | BT30-HBOR32-75 | M 36-52 | 75 | 98 | BT30-H32-35 | HBOR32 | M6 | SRTP3652 | 0.82 |
| 53361309 | BT30-HBOR32-93 | M 36-52 | 93 | 118 | BT30-H32-55 | HBOR32 | M6 | SRTP3652 | 0.79 |
| 54441307 | BT30-HBOR40-75 | M 44-68 | 75 | 98 | BT30-H40-35 | HBOR40 | M6 | SRTP4468 | 0.98 |
| 54441309 | BT30-HBOR40-93 | M 44-68 | 93 | 118 | BT30-H40-55 | HBOR40 | M6 | SRTP4468 | 0.95 |
| 55571309 | BT30-HBOR50-93 | BM 57-90 | 93 | 125 | BT30-H50-45 | HBOR50 | BM8 | SRTP5790 | 1.33 |
| 56701309 | BT30-HBOR63-93 | BM 70-110 | 93 | 145 | BT30-H63-65 | HBOR63 | BM8 | SRTP70110 | 2.18 |
| 52291406 | BT40-HBOR25-60 | M 29-38 | 60 | 90 | BT40-H25-40 | HBOR25 | M5 | SRTP2938 | 1.16 |
| 52291409 | BT40-HBOR25-90 | M 29-38 | 90 | 122 | BT40-H25-72 | HBOR25 | M5 | SRTP2938 | 1.28 |
| 52291412 | BT40-HBOR25-123 | M 29-38 | 123 | 150 | BT40-H25-100 | HBOR25 | M5 | SRTP2938 | 1.40 |
| 52291414 | BT40-HBOR25-145 | M 29-38 | 145 | 177 | BT40-H25-127 | HBOR25 | M5 | SRTP2938 | 1.54 |
| 53361407 | BT40-HBOR32-75 | M 36-52 | 75 | 103 | BT40-H32-40 | HBOR32 | M6 | SRTP3652 | 1.37 |
| 53361410 | BT40-HBOR32-102 | M 36-52 | 102 | 135 | BT40-H32-72 | HBOR32 | M6 | SRTP3652 | 1.57 |
| 53361415 | BT40-HBOR32-150 | M 36-52 | 150 | 183 | BT40-H32-120 | HBOR32 | M6 | SRTP3652 | 1.92 |
| 53361416 | BT40-HBOR32-165 | M 36-52 | 165 | 198 | BT40-H32-135 | HBOR32 | M6 | SRTP3652 | 2.03 |
| 54441407 | BT40-HBOR40-73 | M 44-68 | 73 | 103 | BT40-H40-40 | HBOR40 | M6 | SRTP4468 | 1.58 |
| 54441410 | BT40-HBOR40-102 | M 44-68 | 102 | 135 | BT40-H40-72 | HBOR40 | M6 | SRTP4468 | 1.84 |
| 54441416 | BT40-HBOR40-162 | M 44-68 | 162 | 193 | BT40-H40-130 | HBOR40 | M6 | SRTP4468 | 2.48 |
| 54441421 | BT40-HBOR40-212 | M 44-68 | 212 | 248 | BT40-H40-185 | HBOR40 | M6 | SRTP4468 | 3.05 |
| 55571410 | BT40-HBOR50-102 | BM 57-90 | 102 | 130 | BT40-H50-50 | HBOR50 | BM8 | SRTP5790 | 1.91 |
| 55571414 | BT40-HBOR50-142 | BM 57-90 | 142 | 170 | BT40-H50-90 | HBOR50 | BM8 | SRTP5790 | 2.48 |
| 55571418 | BT40-HBOR50-182 | BM 57-90 | 182 | 210 | BT40-H50-130 | HBOR50 | BM8 | SRTP5790 | 3.25 |
| 55571422 | BT40-HBOR50-222 | BM 57-90 | 222 | 250 | BT40-H50-170 | HBOR50 | BM8 | SRTP5790 | 4.12 |
| 56701410 | BT40-HBOR63-102 | BM 70-110 | 102 | 135 | BT40-H63-55 | HBOR63 | BM8 | SRTP70110 | 2.51 |
| 56701415 | BT40-HBOR63-152 | BM 70-110 | 152 | 185 | BT40-H63-105 | HBOR63 | BM8 | SRTP70110 | 3.72 |
| 56701420 | BT40-HBOR63-202 | BM 70-110 | 202 | 235 | BT40-H63-155 | HBOR63 | BM8 | SRTP70110 | 4.81 |
| 56711410 | BT40-HBOR63-102 | BM 110-150 | 102 | 135 | BT40-H63-55 | HBOR63 | BM8 | SRTP110150 | 2.60 |
| 56711415 | BT40-HBOR63-152 | BM 110-150 | 152 | 185 | BT40-H63-105 | HBOR63 | BM8 | SRTP110150 | 3.81 |
| 56711420 | BT40-HBOR63-202 | BM 110-150 | 202 | 235 | BT40-H63-155 | HBOR63 | BM8 | SRTP110150 | 4.90 |

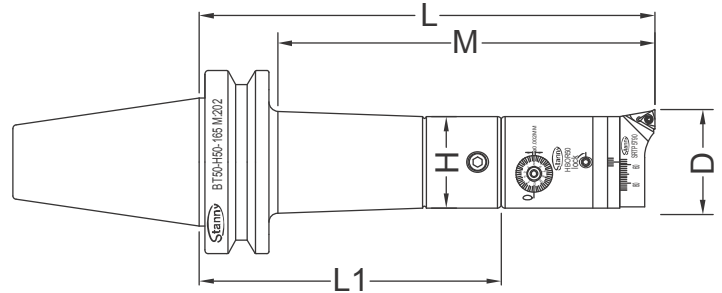

| 訂貨編號 Order No. | 規格 Model | 範圍 D Boring Range øDMin-øDMax | M | L | 精搪孔系統組合 Micro-Finishing Cutter Fine Boring System | | | | 淨重 N.W. |
|-------------------|-----------------|-------------------------------------|-----|-----|--|-----------------------|------------------|-----------------------------------|------------|
| | | | | | 搪孔刀柄 Taper Shank | 精搪孔刀本體 Boring Head | 連接器 Connector | 精搪孔刀座 Cutting Insert Holder | |
| 52291510 | BT50-HBOR25-102 | M 29-38 | 102 | 165 | BT50-H25-115 | | | | 4.31 |
| 52291512 | BT50-HBOR25-127 | M 29-38 | 127 | 190 | BT50-H25-140 | HBOR25 | M5 | SRTP2938 | 4.46 |
| 52291515 | BT50-HBOR25-152 | M 29-38 | 152 | 215 | BT50-H25-165 | | | | 4.56 |
| 53361513 | BT50-HBOR32-135 | M 36-52 | 135 | 198 | BT50-H32-135 | | | | 4.92 |
| 53361516 | BT50-HBOR32-165 | M 36-52 | 165 | 228 | BT50-H32-165 | HBOR32 | | SRTP3652 | 5.17 |
| 53361520 | BT50-HBOR32-200 | M 36-52 | 200 | 263 | BT50-H32-200 | | | | 5.37 |
| 54441513 | BT50-HBOR40-135 | M 44-68 | 135 | 198 | BT50-H40-135 | | | | 5.43 |
| 54441518 | BT50-HBOR40-185 | M 44-68 | 185 | 248 | BT50-H40-185 | HBOR40 | M6 | SRTP4468 | 5.98 |
| 54441522 | BT50-HBOR40-225 | M 44-68 | 225 | 288 | BT50-H40-225 | | | | 6.43 |
| 54441526 | BT50-HBOR40-265 | M 44-68 | 265 | 328 | BT50-H40-265 | | | | 6.83 |
| 55571510 | BT50-HBOR50-102 | BM 57-90 | 102 | 145 | BT50-H50-65 | | | | 4.56 |
| 55571520 | BT50-HBOR50-202 | BM 57-90 | 202 | 245 | BT50-H50-165 | HBOR50 | | SRTP5790 | 6.11 |
| 55571525 | BT50-HBOR50-252 | BM 57-90 | 252 | 295 | BT50-H50-215 | | | | 7.06 |
| 55571530 | BT50-HBOR50-302 | BM 57-90 | 302 | 345 | BT50-H50-265 | | | | 8.22 |
| 56701512 | BT50-HBOR63-122 | BM 70-110 | 122 | 165 | BT50-H63-85 | | | | 5.57 |
| 56701520 | BT50-HBOR63-202 | BM 70-110 | 202 | 245 | BT50-H63-165 | | | | 7.47 |
| 56701525 | BT50-HBOR63-252 | BM 70-110 | 252 | 295 | BT50-H63-215 | | | SRTP70110 | 9.02 |
| 56701530 | BT50-HBOR63-302 | BM 70-110 | 302 | 345 | BT50-H63-265 | | | | 9.97 |
| 56701535 | BT50-HBOR63-352 | BM 70-110 | 352 | 395 | BT50-H63-315 | HBOR63 | BM8 | | 13.22 |
| 56711512 | BT50-HBOR63-122 | BM 110-150 | 122 | 165 | BT50-H63-85 | | | | 5.66 |
| 56711520 | BT50-HBOR63-202 | BM 110-150 | 202 | 245 | BT50-H63-165 | | | | 7.56 |
| 56711525 | BT50-HBOR63-252 | BM 110-150 | 252 | 295 | BT50-H63-215 | | | SRTP110150 | 9.11 |
| 56711530 | BT50-HBOR63-302 | BM 110-150 | 302 | 345 | BT50-H63-265 | | | | 10.06 |
| 56711535 | BT50-HBOR63-352 | BM 110-150 | 352 | 395 | BT50-H63-315 | | | | 13.31 |

搪孔刀柄、精搪孔刀本體、菱形精搪孔刀座 Taper Shank, Body and Rhombus Cutting Insert Holder

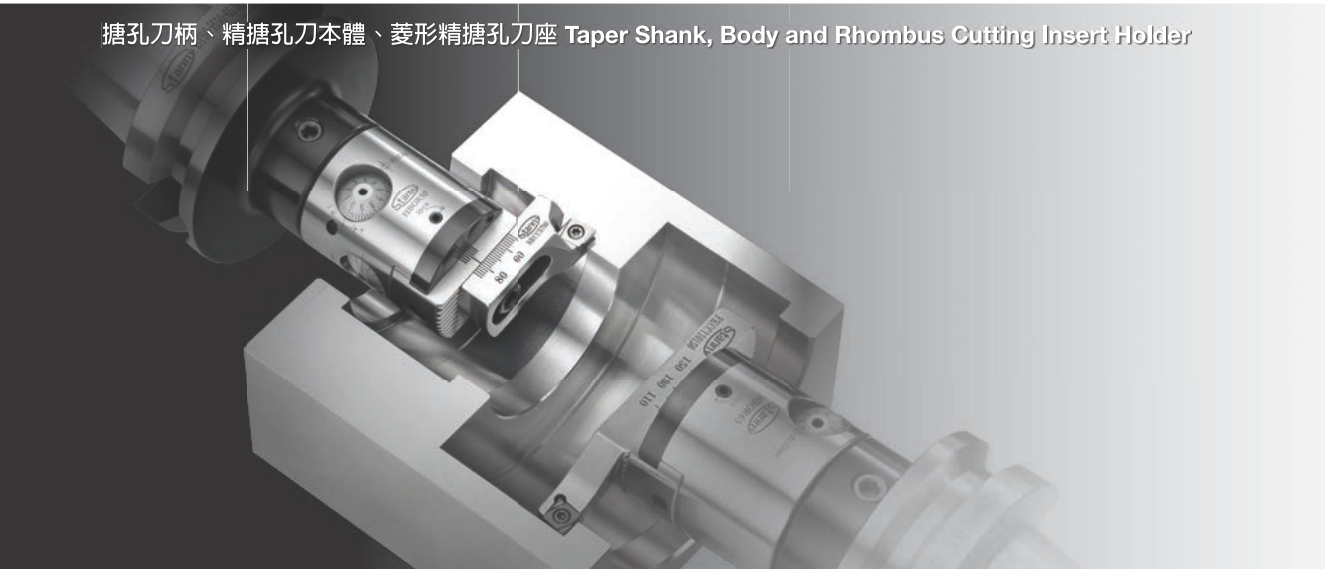

整支 SET

MAS403 BT-HBOR 極細微調精搪孔刀-菱形

MAS403 BT and HBOR Micro-Finishing Rhombus Cutter Fine Boring Head

| 訂貨編號 Order No. | 規格 Model | 範圍 D Boring Range øDMin-øDMax | M | L | 精搪孔系統組合 Micro-Finishing Cutter Fine Boring and Cutting System | | | | 淨重 N.W. | |
|-------------------|-----------------|-------------------------------------|-----|-----|--|-----------------------|------------------|--|------------|------|
| | | | | | 搪孔刀柄 Taper Shank | 精搪孔刀本體 Boring Head | 連接器 Connector | 菱形精搪孔刀座 Rhombus Cutting Insert Holder | | |
| 52291306CC | BT30-HBOR25-60 | MCC 29-38 | 60 | 85 | BT30-H25-35 | HBOR25 | M5 | SRCC2938 | 0.56 | |
| 52291307CC | BT30-HBOR25-75 | MCC 29-38 | 75 | 105 | BT30-H25-55 | | | | 0.62 | |
| 53361307CC | BT30-HBOR32-75 | MCC 36-52 | 75 | 98 | BT30-H32-35 | HBOR32 | M6 | SRCC3652 | 0.82 | |
| 53361309CC | BT30-HBOR32-93 | MCC 36-52 | 93 | 118 | BT30-H32-55 | | | | 0.79 | |
| 54441307CC | BT30-HBOR40-75 | MCC 44-68 | 75 | 98 | BT30-H40-35 | HBOR40 | M6 | SRCC4468 | 0.98 | |
| 54441309CC | BT30-HBOR40-93 | MCC 44-68 | 93 | 118 | BT30-H40-55 | | | | 0.95 | |
| 55571309CC | BT30-HBOR50-93 | BMCC 57-90 | 93 | 125 | BT30-H50-45 | HBOR50 | BM8 | SRCC5790 | 1.33 | |
| 56701309CC | BT30-HBOR63-93 | BMCC 70-110 | 93 | 145 | BT30-H63-65 | | | | 2.18 | |
| 52291406CC | BT40-HBOR25-60 | MCC 29-38 | 60 | 90 | BT40-H25-40 | HBOR25 | M5 | SRCC2938 | 1.16 | |
| 52291409CC | BT40-HBOR25-90 | MCC 29-38 | 90 | 122 | BT40-H25-72 | | | | 1.28 | |
| 52291412CC | BT40-HBOR25-123 | MCC 29-38 | 123 | 150 | BT40-H25-100 | | | | 1.40 | |
| 52291414CC | BT40-HBOR25-145 | MCC 29-38 | 145 | 177 | BT40-H25-127 | | | | 1.54 | |
| 53361407CC | BT40-HBOR32-75 | MCC 36-52 | 75 | 103 | BT40-H32-40 | HBOR32 | M6 | SRCC3652 | 1.37 | |
| 53361410CC | BT40-HBOR32-102 | MCC 36-52 | 102 | 135 | BT40-H32-72 | | | | 1.57 | |
| 53361415CC | BT40-HBOR32-150 | MCC 36-52 | 150 | 183 | BT40-H32-120 | | | | 1.92 | |
| 53361416CC | BT40-HBOR32-165 | MCC 36-52 | 165 | 198 | BT40-H32-135 | | | | 2.03 | |
| 54441407CC | BT40-HBOR40-73 | MCC 44-68 | 73 | 103 | BT40-H40-40 | HBOR40 | M6 | SRCC4468 | 1.58 | |
| 54441410CC | BT40-HBOR40-102 | MCC 44-68 | 102 | 135 | BT40-H40-72 | | | | 1.84 | |
| 54441416CC | BT40-HBOR40-162 | MCC 44-68 | 162 | 193 | BT40-H40-130 | | | | 2.48 | |
| 54441421CC | BT40-HBOR40-212 | MCC 44-68 | 212 | 248 | BT40-H40-185 | | | | 3.05 | |
| 55571410CC | BT40-HBOR50-102 | BMCC 57-90 | 102 | 130 | BT40-H50-50 | HBOR50 | M6 | SRCC5790 | 1.91 | |
| 55571414CC | BT40-HBOR50-142 | BMCC 57-90 | 142 | 170 | BT40-H50-90 | | | | 2.48 | |
| 55571418CC | BT40-HBOR50-182 | BMCC 57-90 | 182 | 210 | BT40-H50-130 | | | | 3.25 | |
| 55571422CC | BT40-HBOR50-222 | BMCC 57-90 | 222 | 250 | BT40-H50-170 | | | | 4.12 | |
| 56701410CC | BT40-HBOR63-102 | BMCC 70-110 | 102 | 135 | BT40-H63-55 | HBOR63 | BM8 | SRCC70110 | 2.51 | |
| 56701415CC | BT40-HBOR63-152 | BMCC 70-110 | 152 | 185 | BT40-H63-105 | | | | 3.72 | |
| 56701420CC | BT40-HBOR63-202 | BMCC 70-110 | 202 | 235 | BT40-H63-155 | | | | 4.81 | |
| 56711410CC | BT40-HBOR63-102 | BMCC 110-150 | 102 | 135 | BT40-H63-55 | | | | 2.60 | |
| 56711415CC | BT40-HBOR63-152 | BMCC 110-150 | 152 | 185 | BT40-H63-105 | HBOR63 | BM8 | SRCC110150 | 3.81 | |
| 56711420CC | BT40-HBOR63-202 | BMCC 110-150 | 202 | 235 | BT40-H63-155 | | | | 4.90 | |
| 56721410CC | BT40-HBOR63-102 | BMCC 150-190 | 102 | 139 | BT40-H63-55 | | | | 2.76 | |
| 56721415CC | BT40-HBOR63-152 | BMCC 150-190 | 152 | 189 | BT40-H63-105 | | | | 3.97 | |
| 56721420CC | BT40-HBOR63-202 | BMCC 150-190 | 202 | 239 | BT40-H63-155 | HBOR63 | BM8 | SRCC150190 | 5.06 | |
| 56731410CC | BT40-HBOR63-102 | BMCC 190-230 | 102 | 139 | BT40-H63-55 | | | | 2.88 | |
| 56731415CC | BT40-HBOR63-152 | BMCC 190-230 | 152 | 189 | BT40-H63-105 | | | | SRCC190230 | 4.09 |
| 56731420CC | BT40-HBOR63-202 | BMCC 190-230 | 202 | 239 | BT40-H63-155 | | | | | 5.18 |

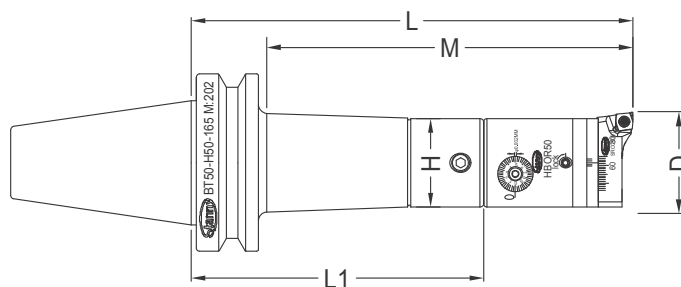

| 訂貨編號 Order No. | 規格 Model | 範圍 D Boring Range øDMin-øDMax | M | L | 精搪孔系統組合 Micro-Finishing Cutter Fine Boring and Cutting System | | | | 淨重 N.W. |
|-------------------|-----------------|-------------------------------------|-----|-----|--|-----------------------|------------------|--|------------|
| | | | | | 搪孔刀柄 Taper Shank | 精搪孔刀本體 Boring Head | 連接器 Connector | 菱形精搪孔刀座 Rhombus Cutting Insert Holder | |
| 52291510CC | BT50-HBOR25-102 | MCC 29-38 | 102 | 165 | BT50-H25-115 | | | | 4.31 |
| 52291512CC | BT50-HBOR25-127 | MCC 29-38 | 127 | 190 | BT50-H25-140 | HBOR25 | M5 | SRCC2938 | 4.46 |
| 52291515CC | BT50-HBOR25-152 | MCC 29-38 | 152 | 215 | BT50-H25-165 | | | | 4.56 |
| 53361513CC | BT50-HBOR32-135 | MCC 36-52 | 135 | 198 | BT50-H32-135 | | | | 4.92 |
| 53361516CC | BT50-HBOR32-165 | MCC 36-52 | 165 | 228 | BT50-H32-165 | HBOR32 | | SRCC3652 | 5.17 |
| 53361520CC | BT50-HBOR32-200 | MCC 36-52 | 200 | 263 | BT50-H32-200 | | | | 5.37 |
| 54441513CC | BT50-HBOR40-135 | MCC 44-68 | 135 | 198 | BT50-H40-135 | | | | 5.43 |
| 54441518CC | BT50-HBOR40-185 | MCC 44-68 | 185 | 248 | BT50-H40-185 | HBOR40 | M6 | SRCC4468 | 5.98 |
| 54441522CC | BT50-HBOR40-225 | MCC 44-68 | 225 | 288 | BT50-H40-225 | | | | 6.43 |
| 54441526CC | BT50-HBOR40-265 | MCC 44-68 | 265 | 328 | BT50-H40-265 | | | | 6.83 |
| 55571510CC | BT50-HBOR50-102 | BMCC 57-90 | 102 | 145 | BT50-H50-65 | | | | 4.56 |
| 55571520CC | BT50-HBOR50-202 | BMCC 57-90 | 202 | 245 | BT50-H50-165 | HBOR50 | | SRCC5790 | 6.11 |
| 55571525CC | BT50-HBOR50-252 | BMCC 57-90 | 252 | 295 | BT50-H50-215 | | | | 7.06 |
| 55571530CC | BT50-HBOR50-302 | BMCC 57-90 | 302 | 345 | BT50-H50-265 | | | | 8.22 |
| 56701512CC | BT50-HBOR63-122 | BMCC 70-110 | 122 | 165 | BT50-H63-85 | | | | 5.57 |
| 56701520CC | BT50-HBOR63-202 | BMCC 70-110 | 202 | 245 | BT50-H63-165 | | | | 7.47 |
| 56701525CC | BT50-HBOR63-252 | BMCC 70-110 | 252 | 295 | BT50-H63-215 | | | SRCC70110 | 9.02 |
| 56701530CC | BT50-HBOR63-302 | BMCC 70-110 | 302 | 345 | BT50-H63-265 | | | | 9.97 |
| 56701535CC | BT50-HBOR63-352 | BMCC 70-110 | 352 | 395 | BT50-H63-315 | | | | 13.22 |
| 56711512CC | BT50-HBOR63-122 | BMCC 110-150 | 122 | 165 | BT50-H63-85 | | | | 5.66 |
| 56711520CC | BT50-HBOR63-202 | BMCC 110-150 | 202 | 245 | BT50-H63-165 | | | | 7.56 |
| 56711525CC | BT50-HBOR63-252 | BMCC 110-150 | 252 | 295 | BT50-H63-215 | | | SRCC110150 | 9.11 |
| 56711530CC | BT50-HBOR63-302 | BMCC 110-150 | 302 | 345 | BT50-H63-265 | | | | 10.06 |
| 56711535CC | BT50-HBOR63-352 | BMCC 110-150 | 352 | 395 | BT50-H63-315 | | | | 13.31 |
| 56721512CC | BT50-HBOR63-122 | BMCC 150-190 | 122 | 169 | BT50-H63-85 | HBOR63 | BM8 | | 5.82 |
| 56721520CC | BT50-HBOR63-202 | BMCC 150-190 | 202 | 249 | BT50-H63-165 | | | | 7.72 |
| 56721525CC | BT50-HBOR63-252 | BMCC 150-190 | 252 | 299 | BT50-H63-215 | | | SRCC150190 | 9.27 |
| 56721530CC | BT50-HBOR63-302 | BMCC 150-190 | 302 | 349 | BT50-H63-265 | | | | 10.22 |
| 56721535CC | BT50-HBOR63-352 | BMCC 150-190 | 352 | 399 | BT50-H63-315 | | | | 13.47 |
| 56731512CC | BT50-HBOR63-122 | BMCC 190-230 | 122 | 169 | BT50-H63-85 | | | | 5.94 |
| 56731520CC | BT50-HBOR63-202 | BMCC 190-230 | 202 | 249 | BT50-H63-165 | | | | 7.84 |
| 56731525CC | BT50-HBOR63-252 | BMCC 190-230 | 252 | 299 | BT50-H63-215 | | | SRCC190230 | 9.39 |
| 56731530CC | BT50-HBOR63-302 | BMCC 190-230 | 302 | 349 | BT50-H63-265 | | | | 10.34 |
| 56731535CC | BT50-HBOR63-352 | BMCC 190-230 | 352 | 399 | BT50-H63-315 | | | | 13.59 |

搪孔刀柄、精搪孔刀本體、精搪孔反搪刀座 Taper Shank, Body and Reverse Cutting Insert Holder



整支 SET

MAS403 BT-HBOR 極細微調反搪精搪孔刀

MAS403 BT and HBOR Micro-Finishing Cutter for Reverse Fine Boring Head

| 訂貨編號 Order No. | 規 格 Model | 範 圍 D Boring Range øDMin-øDMax | M3 | M | L | 反搪精搪孔系統組合 Micro-Finishing Cutter for Reverse Fine Boring and Cutting System | | | | 淨 重 N.W. |
|-------------------|-----------------|--------------------------------------|-------|-----|-----|--|-----------------------|------------------|--|-------------|
| | | | | | | 搪孔刀柄 Taper Shank | 精搪孔刀本體 Boring Head | 連接器 Connector | 精搪孔反搪刀座 Reverse Cutting Insert Holder | |
| | | | | | | | | | | |
| 52291305K | BT30-HBOR25-51 | MK 29-38 | 2-6 | 51 | 87 | BT30-H25-35 | HBOR25 | M5 | FKTP2938 | 0.56 |
| 52291307K | BT30-HBOR25-71 | MK 29-38 | 2-6 | 71 | 107 | BT30-H25-55 | HBOR25 | M5 | FKTP2938 | 0.65 |
| 53361306K | BT30-HBOR32-61 | MK 36-52 | 2-10 | 61 | 99 | BT30-H32-35 | HBOR32 | M6 | FKTP3652 | 0.82 |
| 53361308K | BT30-HBOR32-84 | MK 36-52 | 2-10 | 84 | 119 | BT30-H32-55 | | | | 0.91 |
| 54441306K | BT30-HBOR40-67 | MK 44-68 | 2-14 | 67 | 99 | BT30-H40-35 | HBOR40 | M6 | FKTP4468 | 0.98 |
| 54441308K | BT30-HBOR40-85 | MK 44-68 | 2-14 | 85 | 119 | BT30-H40-55 | | | | 1.16 |
| 55571308K | BT30-HBOR50-85 | BMK 57-90 | 3-20 | 85 | 124 | BT30-H50-45 | HBOR50 | BM8 | FKTP5790 | 1.59 |
| 56701310K | BT30-HBOR63-105 | BMK 70-110 | 3-23 | 105 | 142 | BT30-H63-65 | HBOR63 | | | FKTP70110 |
| 52291405K | BT40-HBOR25-50 | MK 29-38 | 2-6 | 50 | 92 | BT40-H25-40 | HBOR25 | M5 | FKTP2938 | 1.16 |
| 52291408K | BT40-HBOR25-84 | MK 29-38 | 2-6 | 84 | 124 | BT40-H25-72 | | | | 1.28 |
| 52291411K | BT40-HBOR25-113 | MK 29-38 | 2-6 | 113 | 152 | BT40-H25-100 | | | | 1.40 |
| 52291414K | BT40-HBOR25-140 | MK 29-38 | 2-6 | 140 | 179 | BT40-H25-127 | | | | 1.54 |
| 53361406K | BT40-HBOR32-60 | MK 36-52 | 2-10 | 60 | 104 | BT40-H32-40 | HBOR32 | M6 | FKTP3652 | 1.37 |
| 53361409K | BT40-HBOR32-93 | MK 36-52 | 2-10 | 93 | 136 | BT40-H32-72 | | | | 1.57 |
| 53361414K | BT40-HBOR32-141 | MK 36-52 | 2-10 | 141 | 184 | BT40-H32-120 | HBOR32 | M6 | FKTP3652 | 1.92 |
| 53361415K | BT40-HBOR32-156 | MK 36-52 | 2-10 | 156 | 199 | BT40-H32-135 | | | | 2.03 |
| 54441406K | BT40-HBOR40-64 | MK 44-68 | 2-14 | 64 | 106 | BT40-H40-40 | HBOR40 | M6 | FKTP4468 | 1.58 |
| 54441409K | BT40-HBOR40-95 | MK 44-68 | 2-14 | 95 | 136 | BT40-H40-72 | | | | 1.84 |
| 54441415K | BT40-HBOR40-152 | MK 44-68 | 2-14 | 152 | 194 | BT40-H40-130 | HBOR40 | M6 | FKTP4468 | 2.48 |
| 54441420K | BT40-HBOR40-207 | MK 44-68 | 2-14 | 207 | 249 | BT40-H40-185 | | | | 3.05 |
| 55571408K | BT40-HBOR50-84 | BMK 57-90 | 3-20 | 84 | 129 | BT40-H50-50 | HBOR50 | BM8 | FKTP5790 | 1.91 |
| 55571412K | BT40-HBOR50-123 | BMK 57-90 | 3-20 | 123 | 169 | BT40-H50-90 | | | | 2.48 |
| 55571416K | BT40-HBOR50-163 | BMK 57-90 | 3-20 | 163 | 209 | BT40-H50-130 | | | | 3.25 |
| 55571420K | BT40-HBOR50-203 | BMK 57-90 | 3-20 | 203 | 249 | BT40-H50-170 | | | | 4.12 |
| 56701409K | BT40-HBOR63-90 | BMK 70-110 | 3-23 | 90 | 133 | BT40-H63-55 | HBOR63 | BM8 | FKTP70110 | 2.89 |
| 56701414K | BT40-HBOR63-140 | BMK 70-110 | 3-23 | 140 | 183 | BT40-H63-105 | | | | 4.10 |
| 56701419K | BT40-HBOR63-190 | BMK 70-110 | 3-23 | 190 | 233 | BT40-H63-155 | HBOR63 | BM8 | FKTP70110 | 5.19 |
| 56711409K | BT40-HBOR63-90 | BMK 110-150 | 23-43 | 90 | 133 | BT40-H63-55 | | | | 2.99 |
| 56711414K | BT40-HBOR63-140 | BMK 110-150 | 23-43 | 140 | 183 | BT40-H63-105 | HBOR63 | BM8 | FKTP110150 | 4.20 |
| 56711419K | BT40-HBOR63-190 | BMK 110-150 | 23-43 | 190 | 233 | BT40-H63-155 | | | | 5.29 |

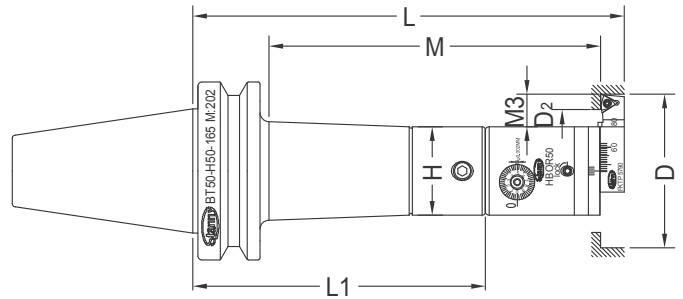

$D_2 > e$
下刀徑: $D_2 \times 2 - D > \text{HBOR}_$

| 訂貨編號 Order No. | 規格 Model | 範圍 D Boring Range $\phi\text{DMin}-\phi\text{DMax}$ | M3 | M | L | 反搪精搪孔系統組合 Micro-Finishing Cutter for Reverse Fine Boring and Cutting System | | | | 淨重 N.W. |
|-------------------|-----------------|---|-------|-----|-----|--|-----------------------|------------------|--|------------|
| | | | | | | 搪孔刀柄 Taper Shank | 精搪孔刀本體 Boring Head | 連接器 Connector | 精搪孔反搪刀座 Reverse Cutting Insert Holder | |
| 52291509K | BT50-HBOR25-94 | MK 29-38 | 2-6 | 94 | 168 | BT50-H25-115 | | | | 4.31 |
| 52291511K | BT50-HBOR25-119 | MK 29-38 | 2-6 | 119 | 193 | BT50-H25-140 | HBOR25 | M5 | FKTP2938 | 4.46 |
| 52291514K | BT50-HBOR25-144 | MK 29-38 | 2-6 | 144 | 218 | BT50-H25-165 | | | | 4.56 |
| 53361512K | BT50-HBOR32-124 | MK 36-52 | 2-10 | 124 | 198 | BT50-H32-135 | | | | 4.92 |
| 53361515K | BT50-HBOR32-154 | MK 36-52 | 2-10 | 154 | 228 | BT50-H32-165 | HBOR32 | | FKTP3652 | 5.17 |
| 53361518K | BT50-HBOR32-189 | MK 36-52 | 2-10 | 189 | 263 | BT50-H32-200 | | | | 5.37 |
| 54441512K | BT50-HBOR40-125 | MK 44-68 | 2-14 | 125 | 199 | BT50-H40-135 | | | | 5.43 |
| 54441517K | BT50-HBOR40-175 | MK 44-68 | 2-14 | 175 | 249 | BT50-H40-185 | HBOR40 | M6 | | 5.98 |
| 54441521K | BT50-HBOR40-215 | MK 44-68 | 2-14 | 215 | 289 | BT50-H40-225 | | | FKTP4468 | 6.43 |
| 54441525K | BT50-HBOR40-255 | MK 44-68 | 2-14 | 255 | 329 | BT50-H40-265 | | | | 6.83 |
| 55571508K | BT50-HBOR50-86 | BMK 57-90 | 3-20 | 86 | 143 | BT50-H50-65 | | | | 4.82 |
| 55571518K | BT50-HBOR50-186 | BMK 57-90 | 3-20 | 186 | 243 | BT50-H50-165 | HBOR50 | | FKTP5790 | 6.37 |
| 55571523K | BT50-HBOR50-236 | BMK 57-90 | 3-20 | 236 | 293 | BT50-H50-215 | | | | 7.32 |
| 55571528K | BT50-HBOR50-286 | BMK 57-90 | 3-20 | 286 | 343 | BT50-H50-265 | | | | 8.22 |
| 56701510K | BT50-HBOR63-105 | BMK 70-110 | 3-23 | 105 | 163 | BT50-H63-85 | | | | 5.95 |
| 56701518K | BT50-HBOR63-185 | BMK 70-110 | 3-23 | 185 | 243 | BT50-H63-165 | | | | 7.85 |
| 56701523K | BT50-HBOR63-235 | BMK 70-110 | 3-23 | 235 | 293 | BT50-H63-215 | HBOR63 | BM8 | FKTP70110 | 9.40 |
| 56701528K | BT50-HBOR63-285 | BMK 70-110 | 3-23 | 285 | 343 | BT50-H63-265 | | | | 10.35 |
| 56701533K | BT50-HBOR63-335 | BMK 70-110 | 3-23 | 335 | 393 | BT50-H63-315 | | | | 13.60 |
| 56711510K | BT50-HBOR63-104 | BMK 110-150 | 23-43 | 104 | 163 | BT50-H63-85 | | | | 6.05 |
| 56711518K | BT50-HBOR63-184 | BMK 110-150 | 23-43 | 184 | 243 | BT50-H63-165 | | | | 7.95 |
| 56711523K | BT50-HBOR63-234 | BMK 110-150 | 23-43 | 234 | 293 | BT50-H63-215 | | | FKTP110150 | 9.50 |
| 56711528K | BT50-HBOR63-284 | BMK 110-150 | 23-43 | 284 | 343 | BT50-H63-265 | | | | 10.45 |
| 56711533K | BT50-HBOR63-334 | BMK 110-150 | 23-43 | 334 | 393 | BT50-H63-315 | | | | 13.70 |

搪孔刀柄、精搪孔刀本體、菱形精搪孔反搪刀座 Taper Shank, Body and Rhombus Reverse Cutting Insert Holder

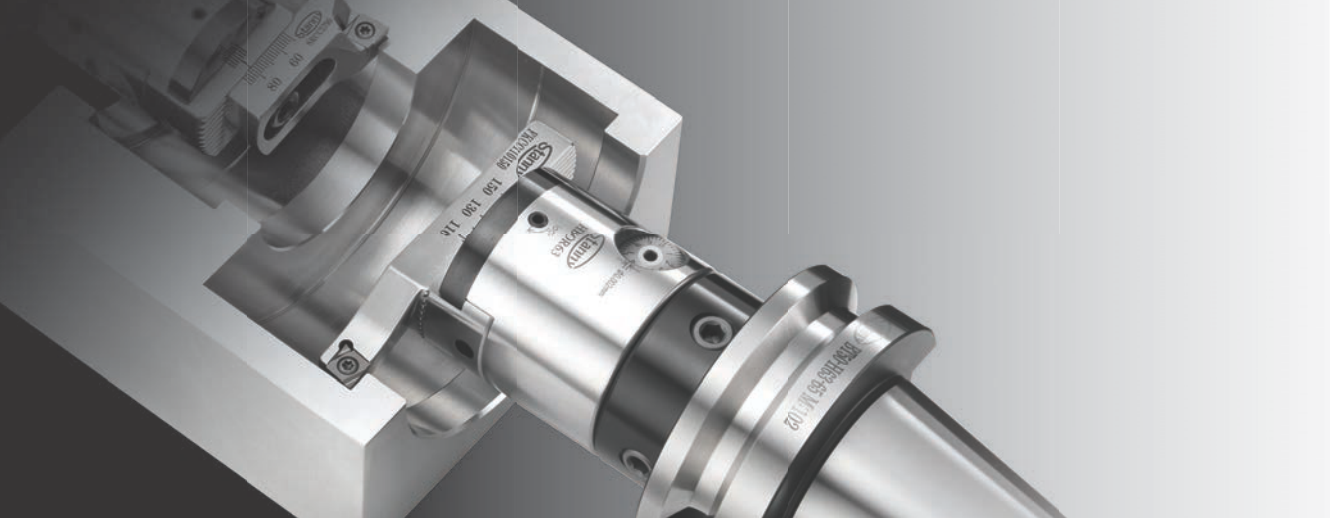

整支 SET

MAS403 BT-HBOR 極細微調菱形反搪精搪孔刀

MAS403 BT and HBOR Micro-Finishing Cutter for Rhombus Reverse Fine Boring Head

| 訂貨編號 Order No. | 規格 Model | 範圍 D Boring Range øDMin-øDMax | M3 | M | L | 反搪精搪孔系統組合 Micro-Finishing Cutter for Reverse Fine Boring and Cutting System | | | | 淨重 N.W. |
|-------------------|-----------------|-------------------------------------|-------|-----|-----|--|---------------------|--|--|------------|
| | | | | | | 搪孔刀柄 Boring Head | 精搪孔刀本體 Connector | 連接器 Rhombus Reverse Cutting Insert Holder | 菱形精搪孔反搪刀座 Rhombus Reverse Cutting Insert Holder | |
| 52291305KC | BT30-HBOR25-51 | MKC 29-38 | 2-6 | 51 | 87 | BT30-H25-35 | HBOR25 | M5 | FKCC2938 | 0.56 |
| 52291307KC | BT30-HBOR25-71 | MKC 29-38 | 2-6 | 71 | 107 | BT30-H25-55 | HBOR25 | M5 | FKCC2938 | 0.65 |
| 53361306KC | BT30-HBOR32-61 | MKC 36-52 | 2-10 | 61 | 99 | BT30-H32-35 | HBOR32 | M6 | FKCC3652 | 0.82 |
| 53361308KC | BT30-HBOR32-84 | MKC 36-52 | 2-10 | 84 | 119 | BT30-H32-55 | HBOR32 | M6 | FKCC3652 | 0.91 |
| 54441306KC | BT30-HBOR40-67 | MKC 44-68 | 2-14 | 67 | 99 | BT30-H40-35 | HBOR40 | M6 | FKCC4468 | 0.98 |
| 54441308KC | BT30-HBOR40-85 | MKC 44-68 | 2-14 | 85 | 119 | BT30-H40-55 | HBOR40 | M6 | FKCC4468 | 1.16 |
| 55571308KC | BT30-HBOR50-85 | BMKC 57-90 | 3-20 | 85 | 124 | BT30-H50-45 | HBOR50 | BM8 | FKCC5790 | 1.59 |
| 56701310KC | BT30-HBOR63-105 | BMKC 70-110 | 3-23 | 105 | 142 | BT30-H63-65 | HBOR63 | BM8 | FKCC70110 | 2.53 |
| 52291405KC | BT40-HBOR25-50 | MKC 29-38 | 2-6 | 50 | 92 | BT40-H25-40 | HBOR25 | M5 | FKCC2938 | 1.16 |
| 52291408KC | BT40-HBOR25-84 | MKC 29-38 | 2-6 | 84 | 124 | BT40-H25-72 | HBOR25 | M5 | FKCC2938 | 1.28 |
| 52291411KC | BT40-HBOR25-113 | MKC 29-38 | 2-6 | 113 | 152 | BT40-H25-100 | HBOR25 | M5 | FKCC2938 | 1.40 |
| 52291414KC | BT40-HBOR25-140 | MKC 29-38 | 2-6 | 140 | 179 | BT40-H25-127 | HBOR25 | M5 | FKCC2938 | 1.54 |
| 53361406KC | BT40-HBOR32-60 | MKC 36-52 | 2-10 | 60 | 104 | BT40-H32-40 | HBOR32 | M6 | FKCC3652 | 1.37 |
| 53361409KC | BT40-HBOR32-93 | MKC 36-52 | 2-10 | 93 | 136 | BT40-H32-72 | HBOR32 | M6 | FKCC3652 | 1.57 |
| 53361414KC | BT40-HBOR32-141 | MKC 36-52 | 2-10 | 141 | 184 | BT40-H32-120 | HBOR32 | M6 | FKCC3652 | 1.92 |
| 53361415KC | BT40-HBOR32-156 | MKC 36-52 | 2-10 | 156 | 199 | BT40-H32-135 | HBOR32 | M6 | FKCC3652 | 2.03 |
| 54441406KC | BT40-HBOR40-64 | MKC 44-68 | 2-14 | 64 | 106 | BT40-H40-40 | HBOR40 | M6 | FKCC4468 | 1.58 |
| 54441409KC | BT40-HBOR40-95 | MKC 44-68 | 2-14 | 95 | 136 | BT40-H40-72 | HBOR40 | M6 | FKCC4468 | 1.84 |
| 54441415KC | BT40-HBOR40-152 | MKC 44-68 | 2-14 | 152 | 194 | BT40-H40-130 | HBOR40 | M6 | FKCC4468 | 2.48 |
| 54441420KC | BT40-HBOR40-207 | MKC 44-68 | 2-14 | 207 | 249 | BT40-H40-185 | HBOR40 | M6 | FKCC4468 | 3.05 |
| 55571408KC | BT40-HBOR50-84 | BMKC 57-90 | 3-20 | 84 | 129 | BT40-H50-50 | HBOR50 | BM8 | FKCC5790 | 1.91 |
| 55571412KC | BT40-HBOR50-123 | BMKC 57-90 | 3-20 | 123 | 169 | BT40-H50-90 | HBOR50 | BM8 | FKCC5790 | 2.48 |
| 55571416KC | BT40-HBOR50-163 | BMKC 57-90 | 3-20 | 163 | 209 | BT40-H50-130 | HBOR50 | BM8 | FKCC5790 | 3.25 |
| 55571420KC | BT40-HBOR50-203 | BMKC 57-90 | 3-20 | 203 | 249 | BT40-H50-170 | HBOR50 | BM8 | FKCC5790 | 4.12 |
| 56701409KC | BT40-HBOR63-90 | BMKC 70-110 | 3-23 | 90 | 133 | BT40-H63-55 | HBOR63 | BM8 | FKCC70110 | 2.89 |
| 56701414KC | BT40-HBOR63-140 | BMKC 70-110 | 3-23 | 140 | 183 | BT40-H63-105 | HBOR63 | BM8 | FKCC70110 | 4.10 |
| 56701419KC | BT40-HBOR63-190 | BMKC 70-110 | 3-23 | 190 | 233 | BT40-H63-155 | HBOR63 | BM8 | FKCC70110 | 5.19 |
| 56711409KC | BT40-HBOR63-90 | BMKC 110-150 | 23-43 | 90 | 133 | BT40-H63-55 | HBOR63 | BM8 | FKCC110150 | 2.99 |
| 56711414KC | BT40-HBOR63-140 | BMKC 110-150 | 23-43 | 140 | 183 | BT40-H63-105 | HBOR63 | BM8 | FKCC110150 | 4.20 |
| 56711419KC | BT40-HBOR63-190 | BMKC 110-150 | 23-43 | 190 | 233 | BT40-H63-155 | HBOR63 | BM8 | FKCC110150 | 5.29 |
| 56721409KC | BT40-HBOR63-90 | BMKC 150-190 | 43-63 | 90 | 138 | BT40-H63-55 | HBOR63 | BM8 | FKCC150190 | 3.03 |
| 56721414KC | BT40-HBOR63-140 | BMKC 150-190 | 43-63 | 140 | 188 | BT40-H63-105 | HBOR63 | BM8 | FKCC150190 | 4.24 |
| 56721419KC | BT40-HBOR63-190 | BMKC 150-190 | 43-63 | 190 | 238 | BT40-H63-155 | HBOR63 | BM8 | FKCC150190 | 5.33 |
| 56731409KC | BT40-HBOR63-90 | BMKC 190-230 | 63-83 | 90 | 138 | BT40-H63-55 | HBOR63 | BM8 | FKCC190230 | 3.10 |
| 56731414KC | BT40-HBOR63-140 | BMKC 190-230 | 63-83 | 140 | 188 | BT40-H63-105 | HBOR63 | BM8 | FKCC190230 | 4.31 |
| 56731419KC | BT40-HBOR63-190 | BMKC 190-230 | 63-83 | 190 | 238 | BT40-H63-155 | HBOR63 | BM8 | FKCC190230 | 5.40 |

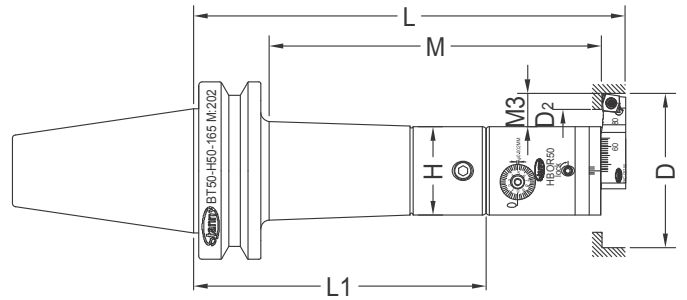

$D_2 > e$
下刀徑: $D_2 \times 2 - D > \text{HBOR}_{\text{---}}$

| 訂貨編號 Order No. | 規格 Model | 範圍 D Boring Range øDMin-øDMax | M3 | M | L | 反搪精搪孔系統組合 Micro-Finishing Cutter for Reverse Fine Boring and Cutting System | | | | 淨重 N.W. |
|-------------------|-----------------|-------------------------------------|-------|-----|-----|--|-----------------------|------------------|--|------------|
| | | | | | | 搪孔刀柄 Taper Shank | 精搪孔刀本體 Boring Head | 連接器 Connector | 菱形精搪孔反搪刀座 Rhombus Reverse Cutting Insert Holder | |
| 52291509KC | BT50-HBOR25-94 | MKC 29-38 | 2-6 | 94 | 168 | BT50-H25-115 | | | | 4.31 |
| 52291511KC | BT50-HBOR25-119 | MKC 29-38 | 2-6 | 119 | 193 | BT50-H25-140 | HBOR25 | M5 | FKCC2938 | 4.46 |
| 52291514KC | BT50-HBOR25-144 | MKC 29-38 | 2-6 | 144 | 218 | BT50-H25-165 | | | | 4.56 |
| 53361512KC | BT50-HBOR32-124 | MKC 36-52 | 2-10 | 124 | 198 | BT50-H32-135 | | | | 4.92 |
| 53361515KC | BT50-HBOR32-154 | MKC 36-52 | 2-10 | 154 | 228 | BT50-H32-165 | HBOR32 | | FKCC3652 | 5.17 |
| 53361518KC | BT50-HBOR32-189 | MKC 36-52 | 2-10 | 189 | 263 | BT50-H32-200 | | | | 5.37 |
| 54441512KC | BT50-HBOR40-125 | MKC 44-68 | 2-14 | 125 | 199 | BT50-H40-135 | | M6 | | 5.43 |
| 54441517KC | BT50-HBOR40-175 | MKC 44-68 | 2-14 | 175 | 249 | BT50-H40-185 | HBOR40 | | FKCC4468 | 5.98 |
| 54441521KC | BT50-HBOR40-215 | MKC 44-68 | 2-14 | 215 | 289 | BT50-H40-225 | | | | 6.43 |
| 54441525KC | BT50-HBOR40-255 | MKC 44-68 | 2-14 | 255 | 329 | BT50-H40-265 | | | | 6.83 |
| 55571508KC | BT50-HBOR50-86 | BMKC 57-90 | 3-20 | 86 | 143 | BT50-H50-65 | | | | 4.82 |
| 55571518KC | BT50-HBOR50-186 | BMKC 57-90 | 3-20 | 186 | 243 | BT50-H50-165 | HBOR50 | | FKCC5790 | 6.37 |
| 55571523KC | BT50-HBOR50-236 | BMKC 57-90 | 3-20 | 236 | 293 | BT50-H50-215 | | | | 7.32 |
| 55571528KC | BT50-HBOR50-286 | BMKC 57-90 | 3-20 | 286 | 343 | BT50-H50-265 | | | | 8.22 |
| 56701510KC | BT50-HBOR63-105 | BMKC 70-110 | 3-23 | 105 | 163 | BT50-H63-85 | | | | 5.95 |
| 56701518KC | BT50-HBOR63-185 | BMKC 70-110 | 3-23 | 185 | 243 | BT50-H63-165 | | | | 7.85 |
| 56701523KC | BT50-HBOR63-235 | BMKC 70-110 | 3-23 | 235 | 293 | BT50-H63-215 | | | FKCC70110 | 9.40 |
| 56701528KC | BT50-HBOR63-285 | BMKC 70-110 | 3-23 | 285 | 343 | BT50-H63-265 | | | | 10.35 |
| 56701533KC | BT50-HBOR63-335 | BMKC 70-110 | 3-23 | 335 | 393 | BT50-H63-315 | | | | 13.60 |
| 56711510KC | BT50-HBOR63-104 | BMKC 110-150 | 23-43 | 104 | 163 | BT50-H63-85 | | | | 6.05 |
| 56711518KC | BT50-HBOR63-184 | BMKC 110-150 | 23-43 | 184 | 243 | BT50-H63-165 | | | | 7.95 |
| 56711523KC | BT50-HBOR63-234 | BMKC 110-150 | 23-43 | 234 | 293 | BT50-H63-215 | | BM8 | FKCC110150 | 9.50 |
| 56711528KC | BT50-HBOR63-284 | BMKC 110-150 | 23-43 | 284 | 343 | BT50-H63-265 | | | | 10.45 |
| 56711533KC | BT50-HBOR63-334 | BMKC 110-150 | 23-43 | 334 | 393 | BT50-H63-315 | HBOR63 | | | 13.70 |
| 56721510KC | BT50-HBOR63-104 | BMKC 150-190 | 43-63 | 104 | 168 | BT50-H63-85 | | | | 6.09 |
| 56721518KC | BT50-HBOR63-184 | BMKC 150-190 | 43-63 | 184 | 248 | BT50-H63-165 | | | | 7.99 |
| 56721523KC | BT50-HBOR63-234 | BMKC 150-190 | 43-63 | 234 | 298 | BT50-H63-215 | | | FKCC150190 | 9.54 |
| 56721528KC | BT50-HBOR63-284 | BMKC 150-190 | 43-63 | 284 | 348 | BT50-H63-265 | | | | 10.49 |
| 56721533KC | BT50-HBOR63-334 | BMKC 150-190 | 43-63 | 334 | 398 | BT50-H63-315 | | | | 13.74 |
| 56731510KC | BT50-HBOR63-104 | BMKC 190-230 | 63-83 | 104 | 168 | BT50-H63-85 | | | | 6.16 |
| 56731518KC | BT50-HBOR63-184 | BMKC 190-230 | 63-83 | 184 | 248 | BT50-H63-165 | | | | 8.06 |
| 56731523KC | BT50-HBOR63-234 | BMKC 190-230 | 63-83 | 234 | 298 | BT50-H63-215 | | | FKCC190230 | 9.61 |
| 56731528KC | BT50-HBOR63-284 | BMKC 190-230 | 63-83 | 284 | 348 | BT50-H63-265 | | | | 10.56 |
| 56731533KC | BT50-HBOR63-334 | BMKC 190-230 | 63-83 | 334 | 398 | BT50-H63-315 | | | | 13.81 |

HBOR25P

極細微調精搪孔系統

Micro-Finishing Cutter Fine Boring System

整組SET G2.5 12000rpm



| 訂貨編號 Order No. | 規格 Model | L1 | 淨重 N.W |
|-------------------|---------------|----|-----------|
| 52161303P | BT30-HBOR25P | 35 | 0.63 |
| 52161404P | BT40-HBOR25P | 40 | 1.22 |
| 52162303P | SK30-HBOR25P | 30 | 0.58 |
| 52162403P | SK40-HBOR25P | 30 | 0.72 |
| 52164604P | HSK63-HBOR25P | 40 | 0.92 |

鎢鋼刀桿 Carbide Bar

| 訂貨編號 Order No. | 規格 Model | 範圍 D Boring Range øDMin-øDMax | 深度 DM | 淨重 N.W |
|-------------------|-------------|-------------------------------------|----------|-----------|
| 50060209T | CA0602-09T | 2-3.2 | 9 | 0.01 |
| 50060316T | CA0603-16T | 3-4.2 | 16 | 0.01 |
| 50060422T | CA0604-22T | 4-5.2 | 22 | 0.02 |
| 50060527T | CA0605-27T | 5-6.2 | 27 | 0.02 |
| 50060632T | CA0606-32T | 6-7.2 | 32 | 0.02 |

鎢鋼刀桿 Carbide Cutting Bar

| 訂貨編號 Order No. | 規格 Model | 範圍 D Boring Range øDMin-øDMax | 深度 DM | 刀片 Insert | 螺絲 Bolt | 板手 Wrench | 淨重 N.W |
|-------------------|-------------|-------------------------------------|----------|--------------|----------------|--------------|-----------|
| 5006605021 | CB06050-21 | 5-6 | 21 | CCGT0301..L | SB-1630TR-M1.6 | T6 | 0.0078 |
| 5006605526 | CB06055-26 | 5.5-6.5 | 26 | | | | 0.0100 |
| 5006606026 | CB06060-26 | 6-7 | 26 | CCGT0301..L | SB-1630TR-M1.6 | T6 | 0.0106 |
| 5006606531 | CB06065-31 | 6.5-7.5 | 31 | | | | 0.0142 |
| 5006607031 | CB06070-31 | 7-8 | 31 | CCGT0401..L | SB-2040TR-M2 | | 0.0146 |

鎢鋼刀桿 Carbide Cutting Bar

| 訂貨編號 Order No. | 規格 Model | 範圍 D Boring Range øDMin-øDMax | 深度 DM | 刀片 Insert | 螺絲 Bolt | 板手 Wrench | 淨重 N.W |
|-------------------|-------------|-------------------------------------|----------|--------------|----------------|--------------|-----------|
| 5006605026 | CB06050-26 | 5-6 | 26 | CCGT0301..L | SB-1630TR-M1.6 | T6 | 0.0090 |
| 5006605531 | CB06055-31 | 5.5-6.5 | 31 | | | | 0.0112 |
| 5006606031 | CB06060-31 | 6-7 | 31 | CCGT0301..L | SB-1630TR-M1.6 | T6 | 0.0124 |
| 5006606536 | CB06065-36 | 6.5-7.5 | 36 | | | | 0.0162 |
| 5006607036 | CB06070-36 | 7-8 | 36 | CCGT0401..L | SB-2040TR-M2 | | 0.0160 |

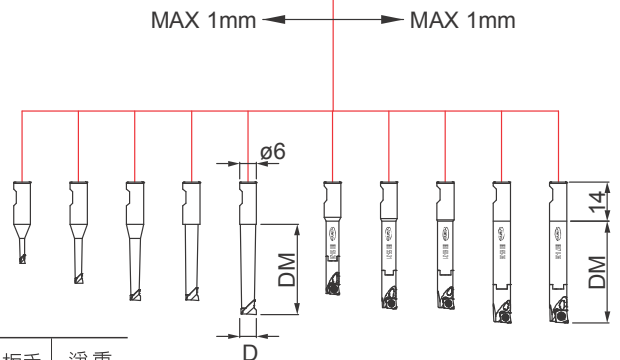
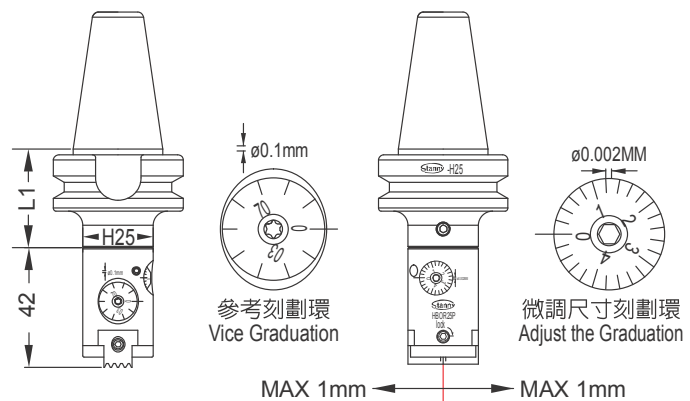

HBOR32P

極細微調精搪孔系統

Micro-Finishing Cutter Fine Boring System

整組SET G2.5 12000rpm



| 訂貨編號 Order No. | 規格 Model | L1 | 淨重 N.W |
|-------------------|---------------|----|-----------|
| 53181303P | BT30-HBOR32P | 35 | 0.76 |
| 53181404P | BT40-HBOR32P | 40 | 1.35 |
| 53182303P | SK30-HBOR32P | 35 | 0.71 |
| 53182403P | SK40-HBOR32P | 35 | 1.3 |
| 53184604P | HSK63-HBOR32P | 40 | 1.32 |

鎢鋼刀桿 Carbide Bar

| 訂貨編號 Order No. | 規格 Model | 範圍 D Boring Range øDMin-øDMax | 深度 DM | 淨重 N.W |
|-------------------|-------------|-------------------------------------|----------|-----------|
| 50080209T | CA0802-09T | 2-3.2 | 9 | 0.03 |
| 50080316T | CA0803-16T | 3-4.2 | 16 | 0.03 |
| 50080422T | CA0804-22T | 4-5.2 | 22 | 0.03 |
| 50080527T | CA0805-27T | 5-6.2 | 27 | 0.04 |
| 50080632T | CA0806-32T | 6-7.2 | 32 | 0.04 |
| 50080737T | CA0807-37T | 7-8.2 | 37 | 0.04 |
| 50080842T | CA0808-42T | 8-9.2 | 42 | 0.05 |

鎢鋼刀桿 Carbide Cutting Bar

| 訂貨編號 Order No. | 規格 Model | 範圍 D Boring Range øDMin-øDMax | 深度 DM | 刀片 Insert | 螺絲 Bolt | 扳手 Wrench | 淨重 N.W |
|-------------------|-------------|-------------------------------------|----------|--------------|--------------|--------------|-----------|
| 5008807031 | CB08070-31 | 7-8 | 31 | CCGT0401..L | SB-2040TR-M2 | T6 | 0.0200 |
| 5008807536 | CB08075-36 | 7.5-8.5 | 36 | | | | 0.0232 |
| 5008808036 | CB08080-36 | 8-9 | 36 | | | | 0.0264 |
| 5008808541 | CB08085-41 | 8.5-9.5 | 41 | | | | 0.0332 |
| 5008809041 | CB08090-41 | 9-10 | 41 | | | | 0.0334 |
| 5008809541 | CB08095-41 | 9.5-10.5 | 41 | | | | 0.0338 |
| 5008810041 | CB08100-41 | 10-11 | 41 | | | | 0.0340 |
| 5008810541 | CB08105-41 | 10.5-11.5 | 41 | | | | 0.0334 |
| 5008811041 | CB08110-41 | 11-12 | 41 | | | | 0.0344 |

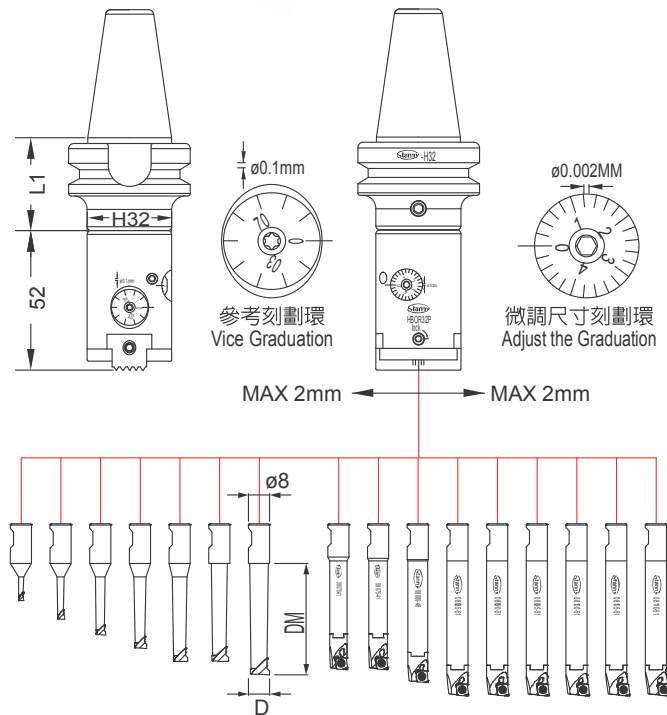

HBOR40P

極細微調精搪孔系統

Micro-Finishing Cutter Fine Boring System

整組SET G2.5 12000rpm



| 訂貨編號 Order No. | 規格 Model | L1 | 淨重 N.W |
|-------------------|---------------|----|-----------|
| 54181303P | BT30-HBOR40P | 35 | 0.95 |
| 54181404P | BT40-HBOR40P | 40 | 1.34 |
| 54182303P | SK30-HBOR40P | 35 | 0.9 |
| 54182403P | SK40-HBOR40P | 35 | 1.29 |
| 54184604P | HSK63-HBOR40P | 45 | 0.92 |

鎢鋼刀桿 Carbide Bar

| 訂貨編號 Order No. | 規格 Model | 範圍 D Boring Range øDMin-øDMax | 深度 DM | 淨重 N.W |
|-------------------|-------------|-------------------------------------|----------|-----------|
| 50080209T | CA0802-09T | 2-3.2 | 9 | 0.03 |
| 50080316T | CA0803-16T | 3-4.2 | 16 | 0.03 |
| 50080422T | CA0804-22T | 4-5.2 | 22 | 0.03 |
| 50080527T | CA0805-27T | 5-6.2 | 27 | 0.04 |
| 50080632T | CA0806-32T | 6-7.2 | 32 | 0.04 |
| 50080737T | CA0807-37T | 7-8.2 | 37 | 0.04 |
| 50080842T | CA0808-42T | 8-9.2 | 42 | 0.05 |

鎢鋼刀桿 Carbide Cutting Bar

| 訂貨編號 Order No. | 規格 Model | 範圍 D Boring Range øDMin-øDMax | 深度 DM | 刀片 Insert | 螺絲 Bolt | 扳手 Wrench | 淨重 N.W |
|-------------------|-------------|-------------------------------------|----------|--------------|--------------|--------------|-----------|
| 5008807041 | CB08070-41 | 7-8 | 41 | CCGT0401..L | SB-2040TR-M2 | T6 | 0.0234 |
| 5008807541 | CB08075-41 | 7.5-8.5 | 41 | | | | 0.0262 |
| 5008808046 | CB08080-46 | 8-9 | 46 | | | | 0.0326 |
| 5008808551 | CB08085-51 | 8.5-9.5 | 51 | | | | 0.0396 |
| 5008809051 | CB08090-51 | 9-10 | 51 | | | | 0.0404 |
| 5008809551 | CB08095-51 | 9.5-10.5 | 51 | | | | 0.0402 |
| 5008810051 | CB08100-51 | 10-11 | 51 | | | | 0.0402 |
| 5008810551 | CB08105-51 | 10.5-11.5 | 51 | | | | 0.0406 |
| 5008811051 | CB08110-51 | 11-12 | 51 | | | | 0.0404 |

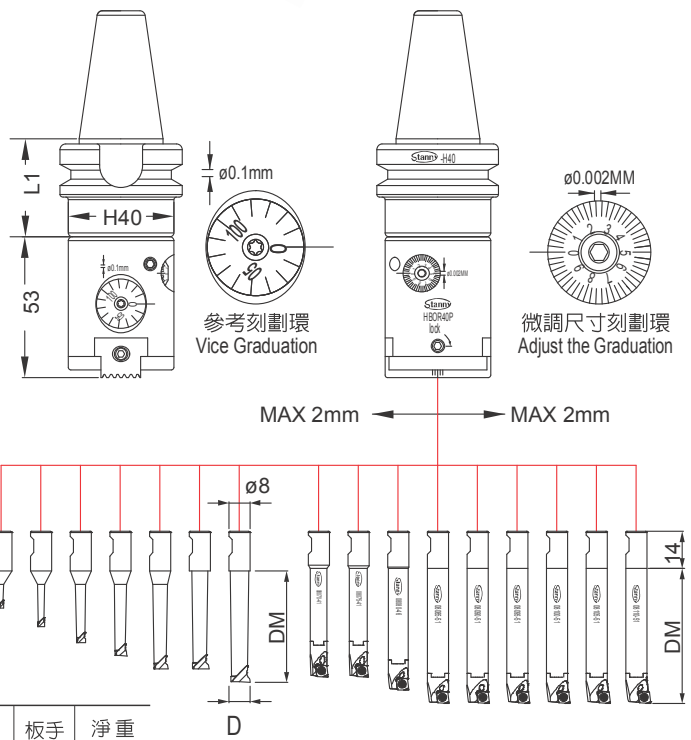

HBOR50P

極細微調精搪孔系統

Micro-Finishing Cutter Fine Boring System

整組SET G2.5 12000rpm $\phi 5 \sim \phi 11$

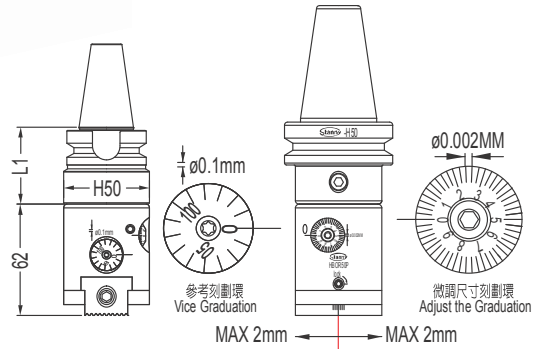

| 訂貨編號 Order No. | 規格 Model | 範圍 D Boring Range $\phi D_{Min} - \phi D_{Max}$ | 組合系統-主軸柄規格 Taper Shank | L1 | 淨重 N.W. |
|-------------------|---------------|---|---------------------------|----|------------|
| 55801304CR | BT30-HBOR50P | 5-11 | MAS403 BT30-H50-45 | 45 | 5.84 |
| 55801405CR | BT40-HBOR50P | 5-11 | MAS403 BT40-H50-50 | 50 | 6.42 |
| 55801506CR | BT50-HBOR50P | 5-11 | MAS403 BT50-H50-65 | 65 | 9.07 |
| 55802305CR | SK30-HBOR50P | 5-11 | DIN69871A ISO30-H50-55 | 55 | 5.97 |
| 55802405CR | SK40-HBOR50P | 5-11 | DIN69871A ISO40-H50-50 | 50 | 6.39 |
| 55802505CR | SK50-HBOR50P | 5-11 | DIN69871A ISO50-H50-50 | 50 | 8.62 |
| 55804605CR | HSK63-HBOR50P | 5-11 | DIN69893A HSK63-H50-57 | 57 | 6.13 |

套筒 Sleeve

| 訂貨編號 Order No. | 規格 Model | 內徑 Inner | L | A螺絲 A-Bolt | 鎢鋼刀桿 Carbide Cutting Bar | 淨重 N.W. |
|-------------------|-------------|-------------|----|---------------|-----------------------------|------------|
| 50081606 | BC1606 | $\phi 6$ | 34 | M5 | CR06... | 0.0542 |
| 50081608 | BC1608 | $\phi 8$ | | M6 | CR08... | 0.0484 |

鎢鋼刀桿 Carbide Cutting Bar

| 訂貨編號 Order No. | 規格 Model | 範圍 D Boring Range $\phi D_{Min} - \phi D_{Max}$ | 深度 DM | 套筒 Sleeve | 刀片 Insert | 螺絲 Bolt | 板手 Wrench | 淨重 N.W |
|-------------------|-------------|---|----------|--------------|--------------|----------------|--------------|-----------|
| 5007605021 | CR06050-21 | 5-6 | 21 | BC1606 | CCGT0301..L | SB-1630TR-M1.6 | T6 | 0.0184 |
| 5007605526 | CR06055-26 | 5.5-6.5 | 26 | | | | | 0.0204 |
| 5007606026 | CR06060-26 | 6-7 | 31 | | | | | 0.0214 |
| 5007606531 | CR06065-31 | 6.5-7.5 | 36 | | | | | 0.0250 |
| 5007607031 | CR06070-31 | 7-8 | 41 | | | | | 0.0250 |
| 5009807031 | CR08070-31 | 7-8 | | | | | | 0.0380 |
| 5009807536 | CR08075-36 | 7.5-8.5 | | 0.0420 | | | | |
| 5009808036 | CR08080-36 | 8-9 | | 0.0450 | | | | |
| 5009808541 | CR08085-41 | 8.5-9.5 | | BC1608 | CCGT0401..L | SB-2040TR-M2 | 0.0518 | |
| 5009809041 | CR08090-41 | 9-10 | | | | | 0.0518 | |
| 5009809541 | CR08095-41 | 9.5-10.5 | | | | | 0.0520 | |
| 5009810041 | CR08100-41 | 10-11 | | | | | 0.0520 | |
| 5009810541 | CR08105-41 | 10.5-11.5 | | | | | 0.0520 | |
| 5009811041 | CR08110-41 | 11-12 | | | | | 0.0524 | |

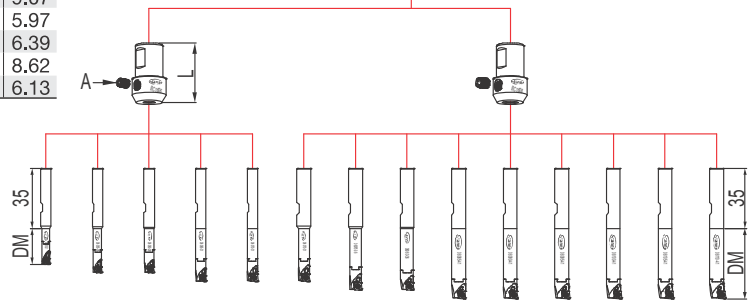

HBOR50P

極細微調精搪孔系統 — 菱形 Micro-Finishing Cutter Fine Boring System

整組SET G2.5 12000rpm $\phi 11 \sim \phi 90$



| 訂貨編號 Order No. | 規格 Model | 範圍 D Boring Range $\phi D_{Min} - \phi D_{Max}$ | 組合系統-主軸柄規格 Taper Shank | L1 | 淨重 N.W. |
|-------------------|---------------|---|---------------------------|----|------------|
| 55801304RM | BT30-HBOR50P | 11-90 | MAS403 BT30-H50-45 | 45 | 6.85 |
| 55801405RM | BT40-HBOR50P | 11-90 | MAS403 BT40-H50-50 | 50 | 7.43 |
| 55801506RM | BT50-HBOR50P | 11-90 | MAS403 BT50-H50-65 | 65 | 10.08 |
| 55802305RM | SK30-HBOR50P | 11-90 | DIN69871A ISO30-H50-55 | 55 | 6.98 |
| 55802405RM | SK40-HBOR50P | 11-90 | DIN69871A ISO40-H50-50 | 50 | 7.40 |
| 55802505RM | SK50-HBOR50P | 11-90 | DIN69871A ISO50-H50-50 | 50 | 9.63 |
| 55804605RM | HSK63-HBOR50P | 11-90 | DIN69893A HSK63-H50-57 | 57 | 7.14 |

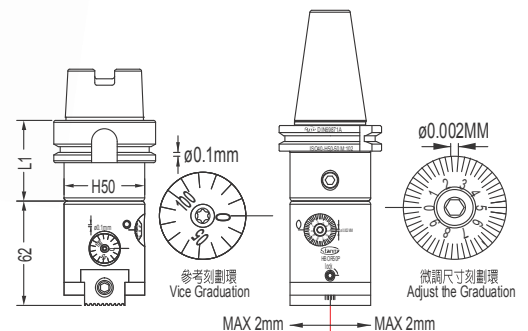

接桿 Shank

| 訂貨編號 Order No. | 規格 Model | X | 深度 DM | C導程螺帽 C-NUT | 螺絲 B-Bolt | 板手 Wrench | 淨重 N.W |
|-------------------|-------------|-----|----------|----------------|--------------|--------------|-----------|
| 50171004 | BRM1610-40 | 45 | 41 | NUT6 | SLCS-M3 | T8 | 0.07 |
| 50171205 | BRM1612-50 | 54 | 51 | NUT7 | SLCS-M4 | T15 | 0.09 |
| 50171405 | BRM1614-55 | 59 | 56 | | | | 0.11 |
| 50171606 | BRM1616-65 | 67 | 66 | NUT9 | SLCS-M5 | T25 | 0.14 |
| 50172008 | BRM1620-80 | 82 | 81 | | | | 0.22 |
| 50172510 | BRM1625-100 | 102 | 101 | | | | 0.41 |
| 50162510 | BM5-100L | 96 | 88+ | | M5×12 | ○4 | 0.40 |
| 50501608 | BM8 | | | | M8×20 | ○6 | 0.03 |

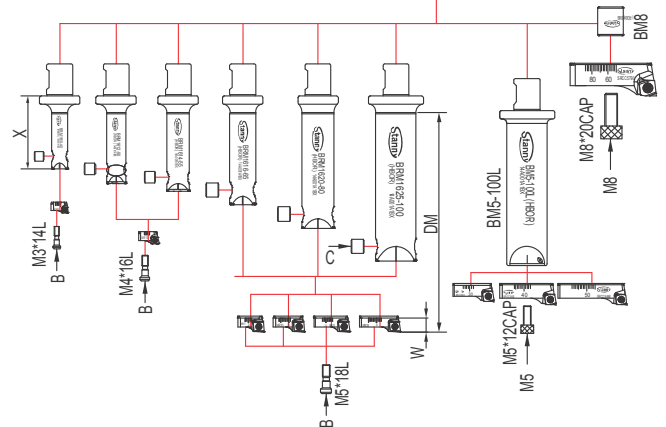

搪孔刀座 Cutting Insert Holder

| 訂貨編號 Order No. | 規格 Model | 範圍 D Boring Range $\phi D_{Min} - \phi D_{Max}$ | 刀座高度 W | 接桿 Shank | 刀片 Insert | 螺絲 Bolt | 板手 Wrench | 淨重 N.W |
|-------------------|-------------|---|-----------|---|--------------|----------------|--------------|-----------|
| 50061114 | MR11 | 11-14 | 6 | BRM1610-40 | CCGT0301..L | SB-1630TR-M1.6 | T6 | 0.002 |
| 50061317 | MR13 | 13-17 | 7 | BRM1612-50 BRM1614-55 | CCGT0401..L | SB-2040TR-M2 | | 0.003 |
| 50061723 | MR17 | 17-23 | 9 | BRM1616-65 BRM1620-80 BRM1625-100 | CCGT0602..L | TS25-M2.5 | T8 | 0.005 |
| 50062026 | MR20 | 20-26 | | | | | | 0.006 |
| 50062329 | MR23 | 23-29 | | | | | | 0.008 |
| 50062632 | MR26 | 26-32 | | | | | | 0.009 |
| 50252938CC | SRCC2938 | 29-38 | 11 | BM5-100L | CCGT09T3..L | TS4-M4 | T15 | 0.010 |
| 50323652CC | SRCC3652 | 36-52 | 13 | | | | | 0.020 |
| 50404468CC | SRCC4468 | 44-68 | 13 | | | | | 0.030 |
| 50505790CC | SRCC5790 | 57-90 | 20 | | | | | 0.100 |

HBOR50

極細微調精搪孔系統 Micro-Finishing Cutter Fine Boring System

整組SET $\phi 6 \sim \phi 90$

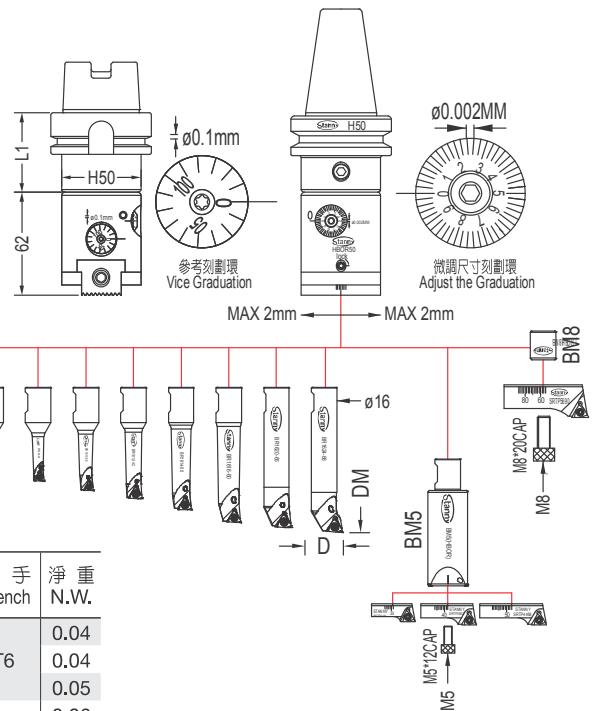

| 訂貨編號 Order No. | 規格 Model | 範圍 D Boring Range $\phi D_{Min} - \phi D_{Max}$ | 組合系統-主軸柄規格 Taper Shank | L1 | 淨重 N.W. |
|-------------------|--------------|---|---------------------------|----|------------|
| 55901309 | BT30-HBOR50 | 6-90 | MAS403 BT30-H50-45 | 45 | 6.7 |
| 55901410 | BT40-HBOR50 | 6-90 | MAS403 BT40-H50-50 | 50 | 7.3 |
| 55901510 | BT50-HBOR50 | 6-90 | MAS403 BT50-H50-65 | 65 | 9.9 |
| 55902309 | SK30-HBOR50 | 6-90 | DIN69871A ISO30-H50-55 | 55 | 6.8 |
| 55902410 | SK40-HBOR50 | 6-90 | DIN69871A ISO40-H50-50 | 50 | 7.3 |
| 55902510 | SK50-HBOR50 | 6-90 | DIN69871A ISO50-H50-50 | 50 | 9.5 |
| 55904610 | HSK63-HBOR50 | 6-90 | DIN69893A HSK63-H50-57 | 57 | 7.0 |

| 訂貨編號 Order No. | 規格 Model | 範圍 D Boring Range $\phi D_{Min} - \phi D_{Max}$ | 深度 DM | 刀片 Insert | 螺絲 Bolt | 扳手 Wrench | 淨重 N.W. |
|-------------------|-------------|---|---------------------------------------|--------------|-------------|--------------|------------|
| 50160621 | BR1606-21 | 6-9 | 21 | WBGT0601..L | | | 0.04 |
| 50160828 | BR1608-28 | 8-11 | 28 | TBGT0601..L | SB-1STR-M2 | T6 | 0.04 |
| 50161035 | BR1610-35 | 10-13 | 35 | | | | 0.05 |
| 50161242 | BR1612-42 | 12-15 | 42 | | | | 0.06 |
| 50161450 | BR1614-50 | 14-17 | 50 | TPGH0902..L | SB-2TR-M2.5 | | 0.07 |
| 50161660 | BR1616-60 | 16-20 | 60 | | | T8 | 0.09 |
| 50162065 | BR1620-65 | 20-24 | 65 | TPGH1103..L | SB-3TR-M3 | | 0.11 |
| 50162468 | BR1624-68 | 24-28 | 68 | | | | 0.12 |
| 50162505 | BM5 | | 60 + SRTP2938 or SRTP3652 or SRTP4468 | | M5x12 | 4 | 0.25 |
| 50252938 | SRTP2938 | 29-38 | 10 | | | | 0.01 |
| 50323652 | SRTP3652 | 36-52 | 12 | TPGH0902..L | SB-2TR-M2.5 | T8 | 0.02 |
| 50404468 | SRTP4468 | 44-68 | 12 | | | | 0.03 |
| 50501608 | BM8 | | | +SRTP5790 | M8x20 | 6 | 0.03 |
| 50505790 | SRTP5790 | 57-90 | 20 | TPGH1103..L | SB-3TR-M3 | T8 | 0.10 |

HBOR63P

極細微調精搪孔系統

Micro-Finishing Cutter Fine Boring System

整組SET G2.5 12000rpm $\phi 5 \sim \phi 11$

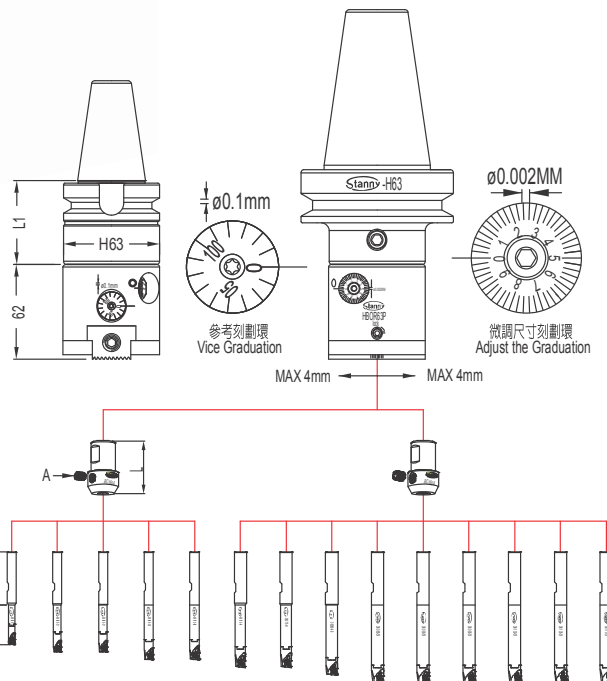

| 訂貨編號 Order No. | 規格 Model | 範圍 D Boring Range $\phi D_{Min} - \phi D_{Max}$ | 組合系統-主軸柄規格 Taper Shank | L1 | 淨重 N.W. |
|-------------------|---------------|---|---------------------------|----|------------|
| 56801405CR | BT40-HBOR63P | 5-11 | MAS403 BT40-H63-55 | 55 | 7.2 |
| 56801506CR | BT50-HBOR63P | 5-11 | MAS403 BT50-H63-65 | 65 | 9.8 |
| 56801508CR | BT50-HBOR63P | 5-11 | MAS403 BT50-H63-85 | 85 | 10.3 |
| 56802406CR | SK40-HBOR63P | 5-11 | DIN69871A ISO40-H63-60 | 60 | 7.2 |
| 56802506CR | SK50-HBOR63P | 5-11 | DIN69871A ISO50-H63-65 | 65 | 9.0 |
| 56804606CR | HSK63-HBOR63P | 5-11 | DIN69893A HSK63-H63-67 | 67 | 7.0 |

套筒 Sleeve

| 訂貨編號 Order No. | 規格 Model | 內徑 Inner | L | A螺絲 A-Bolt | 鎢鋼刀桿 Carbide Cutting Bar | 淨重 N.W. |
|-------------------|-------------|-------------|----|---------------|-----------------------------|------------|
| 50081606 | BC1606 | $\phi 6$ | 34 | M5 | CR06... | 0.0542 |
| 50081608 | BC1608 | $\phi 8$ | | M6 | CR08... | 0.0484 |

鎢鋼刀桿 Carbide Cutting Bar

| 訂貨編號 Order No. | 規格 Model | 範圍 D Boring Range $\phi D_{Min} - \phi D_{Max}$ | 深度 DM | 套筒 Sleeve | 刀片 Insert | 螺絲 Bolt | 板手 Wrench | 淨重 N.W. |
|-------------------|-------------|---|----------|--------------|--------------|----------------|--------------|------------|
| 5007605026 | CR06050-26 | 5-6 | 26 | BC1606 | CCGT0301..L | SB-1630TR-M1.6 | T6 | 0.0192 |
| 5007605531 | CR06055-31 | 5.5-6.5 | 31 | | | | | 0.0216 |
| 5007606031 | CR06060-31 | 6-7 | 36 | | | | | 0.0228 |
| 5007606536 | CR06065-36 | 6.5-7.5 | 36 | | | | | 0.0268 |
| 5007607036 | CR06070-36 | 7-8 | | | CCGT0401..L | SB-2040TR-M2 | 0.0268 | |
| 5009807041 | CR08070-41 | 7-8 | 41 | BC1608 | CCGT0401..L | SB-2040TR-M2 | T6 | 0.0424 |
| 5009807541 | CR08075-41 | 7.5-8.5 | 46 | | | | | 0.0448 |
| 5009808046 | CR08080-46 | 8-9 | 51 | | | | | 0.0512 |
| 5009808551 | CR08085-51 | 8.5-9.5 | | | | | | 0.0586 |
| 5009809051 | CR08090-51 | 9-10 | | | | | | 0.0586 |
| 5009809551 | CR08095-51 | 9.5-10.5 | | | | | | 0.0590 |
| 5009810051 | CR08100-51 | 10-11 | | | | | | 0.0590 |
| 5009810551 | CR08105-51 | 10.5-11.5 | | | | | | 0.0592 |
| 5009811051 | CR08110-51 | 11-12 | | | | | | 0.0592 |

HBOR63P

極細微調精搪孔系統

Micro-Finishing Cutter Fine Boring System

整組SET G2.5 12000rpm $\phi 11 \sim \phi 32$



| 訂貨編號 Order No. | 規格 Model | 範圍D Boring Range $\phi D_{Min} - \phi D_{Max}$ | 組合系統-主軸柄規格 Taper Shank | L1 | 淨重 N.W. |
|-------------------|---------------|--|---------------------------|----|------------|
| 56801405 | BT40-HBOR63P | 11-32 | MAS403 BT40-H63-55 | 55 | 7.5 |
| 56801506 | BT50-HBOR63P | 11-32 | MAS403 BT50-H63-65 | 65 | 10.06 |
| 56801508 | BT50-HBOR63P | 11-32 | MAS403 BT50-H63-85 | 85 | 10.56 |
| 56802406 | SK40-HBOR63P | 11-32 | DIN69871A ISO40-H63-60 | 60 | 7.54 |
| 56802506 | SK50-HBOR63P | 11-32 | DIN69871A ISO50-H63-65 | 65 | 9.26 |
| 56804606 | HSK63-HBOR63P | 11-32 | DIN69893A HSK63-H63-67 | 67 | 7.39 |

套筒 Sleeve

| 訂貨編號 Order No. | 規格 Model | 內徑 Inner | L | A螺絲 A-Bolt | 鎢鋼柄 Carbide Shank | 淨重 N.W. |
|-------------------|-------------|-------------|----|---------------|----------------------|------------|
| 50081610 | BC1610 | $\phi 10$ | 34 | M8 | CM10 | 0.06 |
| 50081612 | BC1612 | $\phi 12$ | | | CM12 | 0.05 |
| 50081614 | BC1614 | $\phi 14$ | | | CM14 | 0.04 |

鎢鋼柄 Carbide Shank

| 訂貨編號 Order No. | 規格 Model | 外徑 Outer | L2 | C導程螺帽 C-NUT | B螺絲 B-Bolt | 淨重 N.W. |
|-------------------|-------------|-------------|-----|----------------|---------------|------------|
| 50071009 | CM10 | $\phi 10$ | 99 | NUT6 | SLCS-M3 | 0.10 |
| 50071211 | CM12 | $\phi 12$ | 112 | NUT7 | SLCS-M4 | 0.16 |
| 50071411 | CM14 | $\phi 14$ | 115 | NUT7 | SLCS-M4 | 0.21 |
| 50071613 | CM16 | $\phi 16$ | 135 | NUT9 | SLCS-M5 | 0.35 |

MR (正搪) 和MK (反搪) 搪孔刀座

MR and MK(Reverse) Cutting Insert Holder

| 訂貨編號 Order No. | 規格 Model | 範圍D Boring Range $\phi D_{Min} - \phi D_{Max}$ | | 刀座高度 | | 深度 DM | L | 鎢鋼柄 Carbide Shank | 套筒 Sleeve | 刀片 Insert | 螺絲 Bolt | 扳手 Wrench | 淨重 N.W. |
|-------------------|-------------|--|----|------|----|----------|-----|-------------------------|--------------|--------------|----------------|--------------|------------|
| | | W | WK | W | WK | | | | | | | | |
| 50061114 | MR11 | 11-14 | | 6 | | 72 | 105 | CM10 | BC1610 | CCGT0301..L | SB-1630TR-M1.6 | T6 | 0.002 |
| 50061317 | MR13 | 13-17 | | 7 | | 86 | 119 | CM12 | BC1612 | CCGT0401..L | SB-2040TR-M2 | T6 | 0.003 |
| 50061723 | MR17 | 17-23 | | 9 | | 124 | 144 | CM16 | | CCGT0602..L | TS25-M2.5 | T8 | 0.005 |
| 50062026 | MR20 | 20-26 | | | | | | | | | | | 0.006 |
| 50062329 | MR23 | 23-29 | | | | | | | | | | | 0.008 |
| 50062632 | MR26 | 26-32 | | | | | | | | | | | 0.009 |
| 50051114 | MK11 | 11-14 | | 7 | 6 | 59 | 106 | CM10 | BC1610 | CCGT0301..R | SB-1630TR-M1.6 | T6 | 0.002 |
| 50051317 | MK13 | 13-17 | | 8 | 7 | 72 | 120 | CM12 | BC1612 | CCGT0401..R | SB-2040TR-M2 | | 0.003 |
| 50051723 | MK17 | 17-23 | | 10 | 9 | 115 | 145 | CM16 | | CCGT0602..R | TS25-M2.5 | | T8 |
| 50052026 | MK20 | 20-26 | | | | | | | | | | 0.007 | |
| 50052329 | MK23 | 23-29 | | | | | | | | | | 0.009 | |
| 50052632 | MK26 | 26-32 | | | | | | | | | | 0.011 | |

