

ROYAL
Royal Precision Tools Corporation

High Precision Spindles Solutions

Total Solution • State of the Art



PRECISION

STABILITY

RIGIDITY

EFFICIENCY

Direct-Drive Spindle

- ▶ High dynamic rotary accuracy
- ▶ High precision, low vibration
- ▶ Same flange dimensions, high adaptability



Model	Housing OD (mm)	Max. Speed (rpm)	Taper	Clamping force (kgf)	Bearing ID (mm)	Lubrication	Cooling	Weight (kg)	CTS
RD3068	Ø100	24000	BT30/BBT30	250±50	Ø40	Grease Oil-air	Oil	Approx. 38	Optional
RD3006	Ø120	18000	BT30/BBT30	350±50	Ø60			Approx. 38	
RD4172		15000	BT40/BBT40	900±100	Ø60			Approx. 38	
RDH085		HSK A63	1800~2300	Ø60	Approx. 38				
RD4230	Ø150	12000	BT40/BBT40	1200~1320	Ø70			Approx. 60	
RD4152		18000	BT40/BBT40	1200±100	Ø70			Approx. 60	
RDH069		HSK A63	1800~2300	Ø70	Approx. 60				
RD4014	Ø155	15000	BT40/BBT40	1000±100	Ø70			Approx. 80	
RD5012		10000	BT50/BBT50	1500±100	Ø80			Approx. 70	
RD5002	Ø190	12000	BT50/BBT50	1800±100	Ø90			Approx. 112	
RDH061			HSK A100	4500~5800	Ø90			Approx. 112	
RD5059	Ø200	12000	BT50/BBT50	1800±100	Ø100			Approx. 134	
RDH008			HSK A100	4500~5800	Ø100			Approx. 134	

RD3006

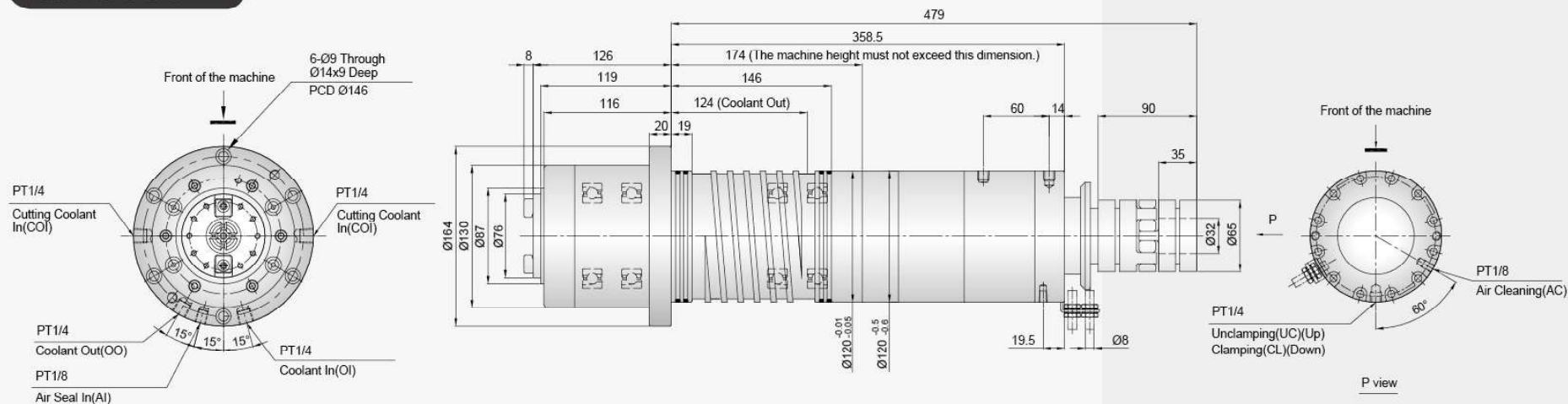

RD4172

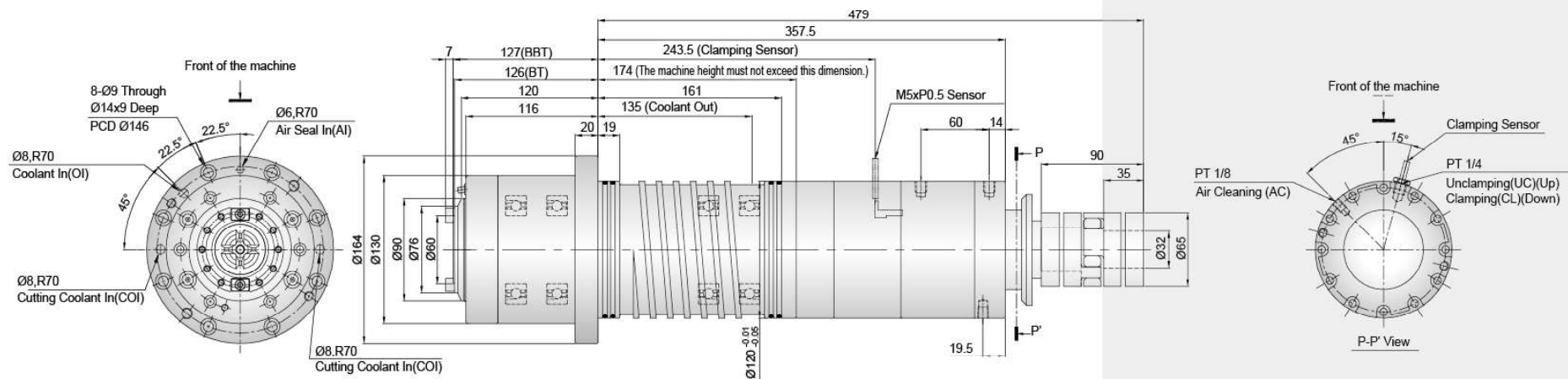

RD4152

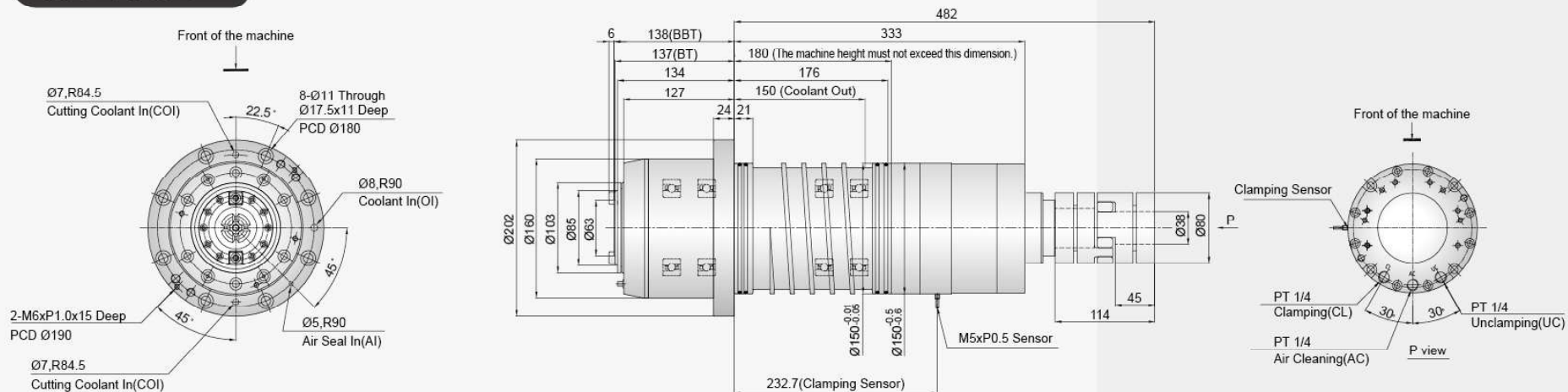

RDH069

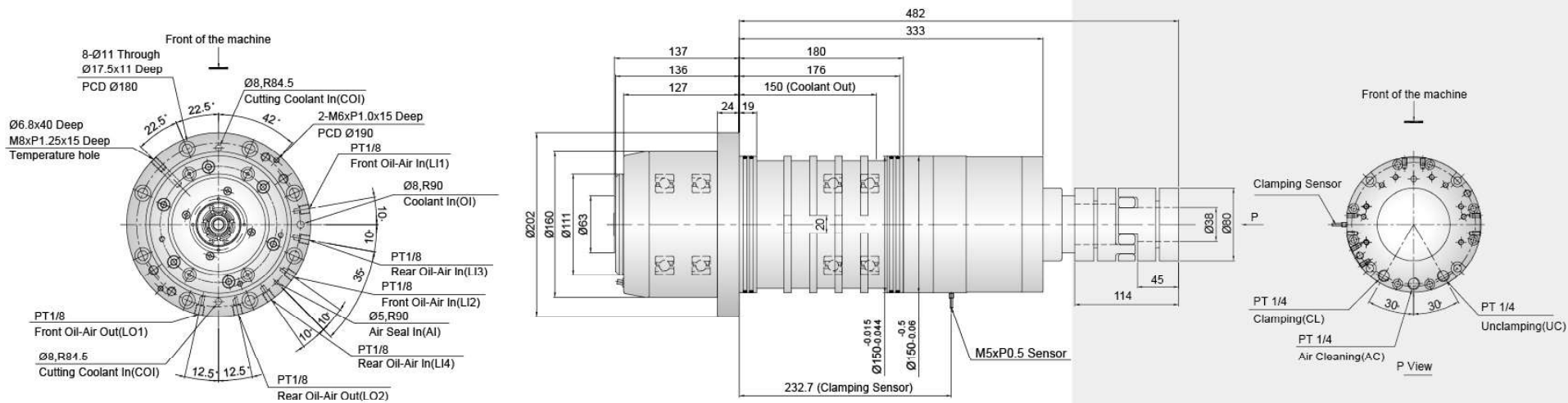

RD4230

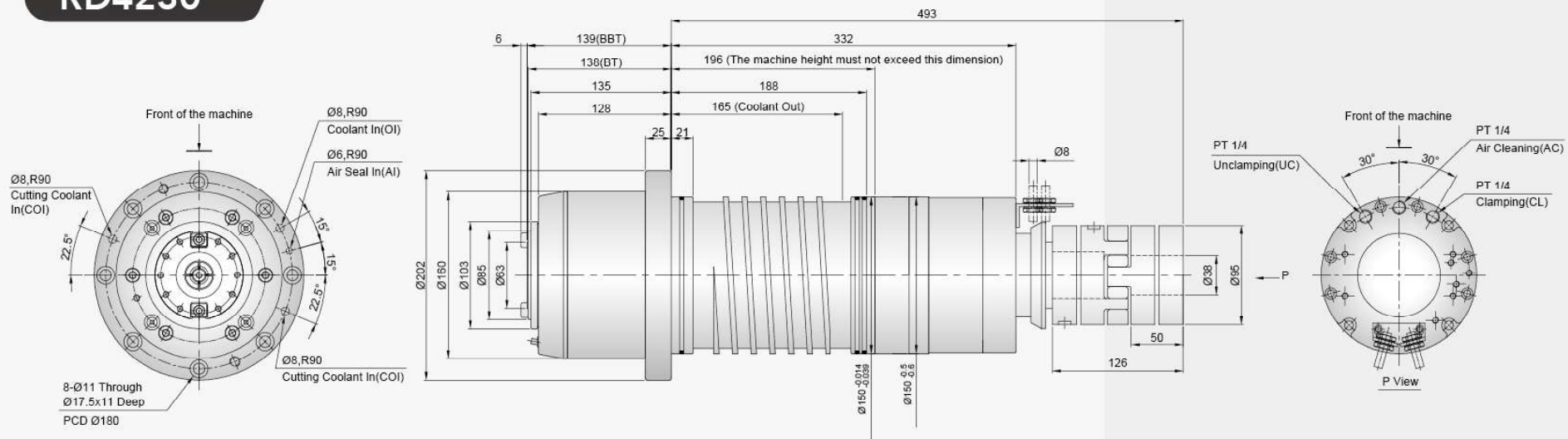

RD5002

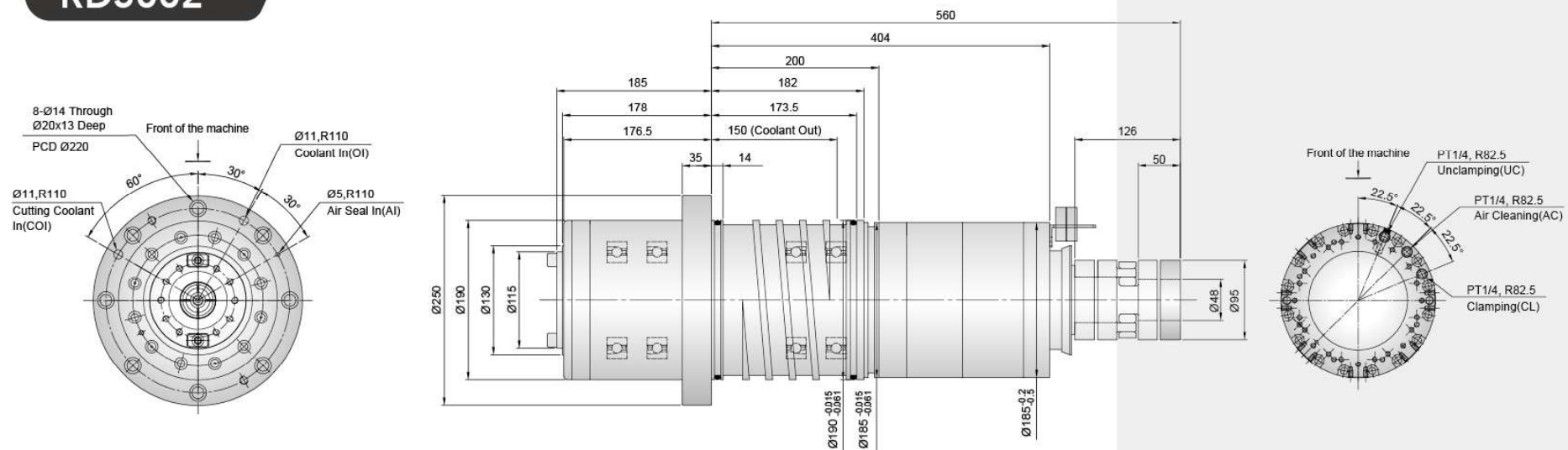

Direct-Drive Spindle



Model	Housing OD (mm)	Max. Speed (rpm)	Taper	Clamping force (kgf)	Bearing ID (mm)	Lubrication	Cooling	Weight (kg)	CTS
RD4187	Ø150	12000	BBT40	1200~1320	Ø70	Grease	Oil	Approx. 58	Optional

RD4187

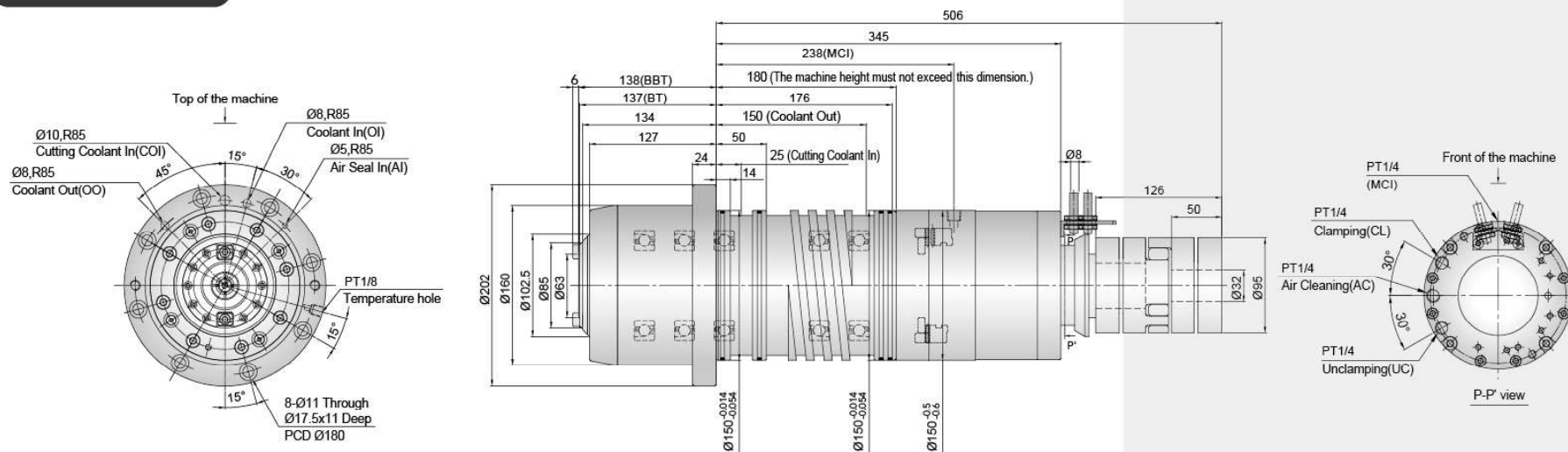

Direct-Drive Spindle



Model	Housing OD (mm)	Max. Speed (rpm)	Bearing ID (mm)	Lubrication	Weight (kg)
RG0024	Ø130	3000	Ø65	Grease	Approx. 80

RG0024

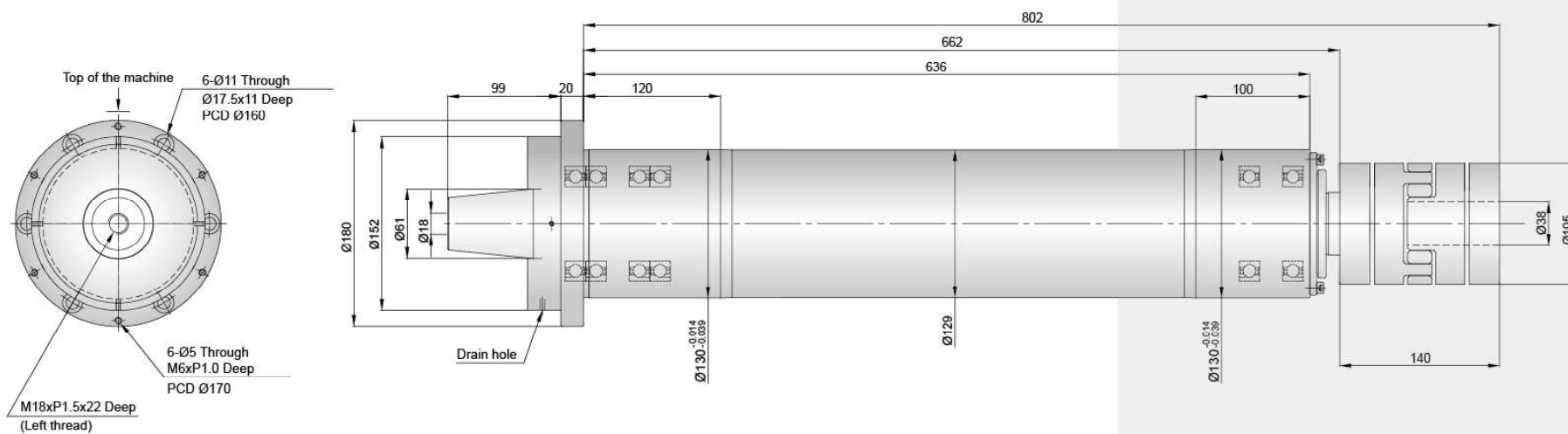

Your Spindle Solutions
Speed, Precision, Rigidity

ROYAL

Royal Precision Tools Corporation

Head office

No. 21, Sec. 1, Zhongshan Rd., Wuri Dist.,
Taichung City 414, Taiwan

TEL: +886 4 2338 2068

FAX: +886 4 2338 2161

E-mail : royal_sa@royal-spindles.com.tw

Jiji, Nantou

No. 66, Zhongji Rd., Jiji Township,
Nantou County 552, Taiwan

TEL: +886 4 2338 2068

FAX: +886 49 276 2812



www.royal-spindles.com