

機台規格 SPECIFICATION:

型式 MODEL		SD-15	SD-25	SD-32	SD-45	SD-52	
彈性夾頭 夾持能力 Maximum chucking capacity(mm)	圓形 Bar stock	●	∅15	∅25	∅32	∅45	∅52
	四角形 Square	■	10	18	22	32	37
	六角形 Hexagonal	◆	12	22	27	38	45
主軸迴轉速度 Spindle speeds (RPM)		3速(Speeds) 1118/1720/2800	3速(Speeds) 1050/1720/2800	4速(Speeds) 636/1020/1575/2656	4速(Speeds) 557/894/1379/2364	4速(Speeds) 557/894/1379/2364	
刀架滑板 Tool holder slides (mm)	主滑板最大行程(前後) Max. main slide travel (forward and backward)	75	110	110	110	110	
	前副滑板最大行程 Max. front cross slide travel	76	75	100	100	100	
	前副滑板傾斜角度 Front cross slide swivels	360°	360°	360°	360°	360°	
	後副滑板最大行程 Max. rear cross slide travel	60	60	100	100	100	
	後副滑板可調距離 Lateral adjustment of rear cross slide	35	60	60	60	60	
尾座 Tailstock (mm)	尾座軸外徑 Tailstock spindle dia.	∅20	∅30	∅38	∅38	∅38	
	斜度(斜柄/鑽頭) Tailstock spindle taper	MT1/JT2	MT2/JT6	MT3/JT6	MT3/JT6	MT3/JT6	
	尾座行程 Tailstock spindle travel	82	100	100	100	100	
床面至中心高度 Base to centers high (mm)		100	126	168	168	168	
兩中心距離 Distance between centers (mm)		160	270	270	270	270	
馬達 Motor (HP)		1HP	2HP	2HP	2HP	2HP	
機械尺寸 Machine dimension LxWxH (mm)		680x380x950	1070x450x1100	1090x480x1100	1090x480x1100	1090x480x1100	
淨重 New weight (kgs)		135	240	360	410	410	
裝箱尺寸 Packing dimension LxWxH (mm)		1台 Set 850x550x1170	1090x600x1350	1100x700x1350	1100x700x1350	1100x700x1350	
		2台 Set 970x850x1170	—	—	—	—	

• 本公司產品規格、設計特性均不斷研究改進，規格若有變動，恕不另行通知。 All specifications, dimensions and design characteristics shown in this catalogue are subject to change without notice.

標準配件 Standard Accessories

- 夾頭斜頭柄 1支  
Chuck arbor 1 pc
- 調整工具 1組  
Adjusting tool 1 set
- 潤滑油 1瓶  
Lubricant 1 bottle
- 彈性夾頭 1只  
Collet chuck 1 pc

選購配件 Optional Accessories

- 上部切刀架V1  
Over cutter V1
- 上部切刀架V2  
Over cutter V2
- 自動送料架  
Auto bar feeder
- 冷卻裝置  
Coolant equipment
- 彈性夾頭  
Various collet chuck
- 氣壓自動夾持裝置  
Pneumatically automatic  
collet chucking device



高速精密桌上車床  
PLC油壓自動車床



High Speed Precision Bench Lathe  
PLC Hydraulic Automatic Lathe



昇岱實業股份有限公司  
SENDAY ENTERPRISE CO., LTD.

408台中市南屯區精科三路2號  
No. 2, Jingke 3<sup>rd</sup> Road, Nantun Dist., Taichung City, Taiwan  
TEL: 886-4-23504090 FAX: 886-4-23502399  
E-mail: senday@ms12.hinet.net Http://www.senday.com.tw

昇岱實業股份有限公司  
SENDAY ENTERPRISE CO., LTD.



多功能！自動化！創造競爭優勢的新產品

Maximum Versatility! High Automation!  
Designed and Engineered to Upgrade  
Competitive Edge for You.



● 變頻馬達 (標準配備)  
**INVERTER MOTOR (STANDARD)**

提供主軸的無段變速，適合各種工件材質之加工。  
It provides variable speed change for spindle, making the machine suitable for cutting various workpiece materials.



● 人機介面控制器  
**HMI CONTROL**

附一般操作面板。所有動作集中操控。  
Equipped with a common control panel for centralized motions control.

● 5HP 電磁離合器搭配 3HP 馬達，提供更快煞車速度。(選配件)  
5HP magnetic clutch combined with 3HP motor drive assure faster braking. (Optional Accessories)

● 高性質油壓系統  
**HIGH PERFORMANCE HYDRAULIC SYSTEM**

提供穩定、順暢的機器動作，低噪音，使用壽命長。  
The hydraulic system provides extremely stable and smooth motions. Also, featuring low noise and long service life.

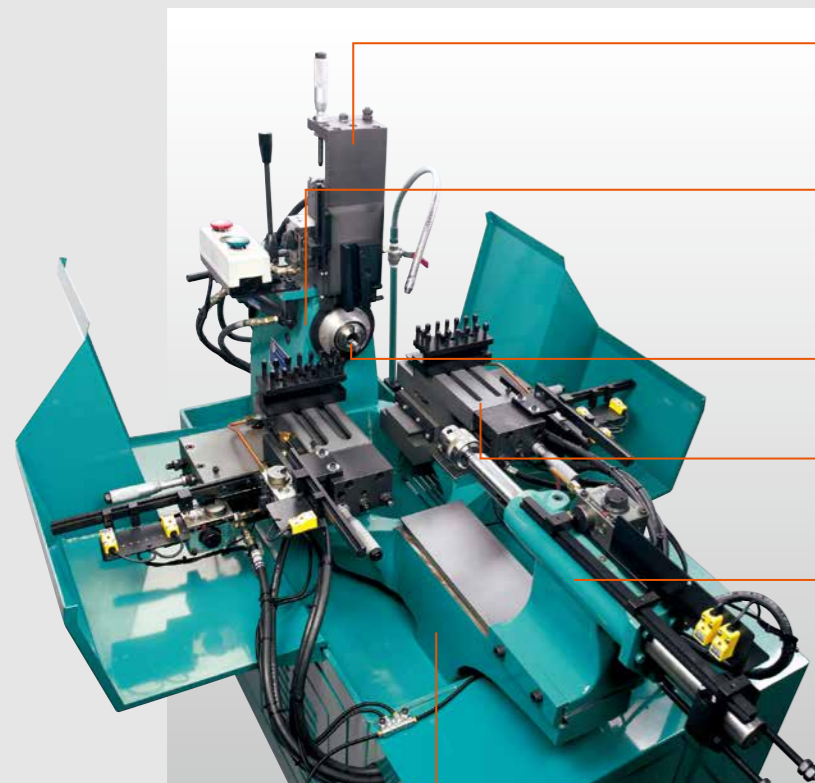

● 上部切刀架 **OVER CUTTER**

可執行工件切斷，並且有多溝槽及外徑車削功能。  
In addition to perform cut-off purpose the over cutter also can be applied for cutting multiple necks and turning outside diameter.

● 高剛性主軸頭 **RIGID HEADSTOCK**

採用浸油式自動循環潤滑系統，重切削時穩定性優異。  
The headstock employs oil bath automatically circulated lubrication system. It features maximum stability when performing heavy cutting.

● 彈性夾頭 **COLLET CHUCK**

可快速方便的工作夾緊或放鬆，不必停止馬達運轉。多種彈性夾頭可選擇。  
It provides fast workpiece chucking and releasing without stopping motor. Various types of collect chucks are available to choose from.

● 雙油壓滑座 **DOUBLE HYDRAULIC TOOL SLIDES**

具多功能車削特性，大幅提升加工效率。  
Designed for providing multi-function turning and greatly increasing efficiency.

● 單油壓尾座 **SINGLE HYDRAULIC TAILSTOCK**

提供鑽孔，及頂心作業。  
Allows for drilling and accommodates center.

中空型床身  
**HOLLOW BED**

方便切屑排除，避免切屑累積於床身。  
Specially designed for efficient chip exhaust without depositing on the bed.



側邊刀座 (選配件)  
上切刀座可選配十字  
**V2 slide, Cross slides (Optional)**

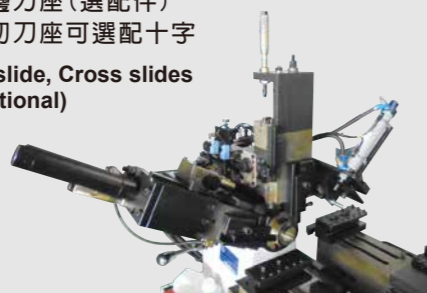

雙油壓尾座 (選配件)  
**DOUBLE HYDRAULIC TAILSTOCKS (OPTIONAL)**

提供鑽孔，攻牙一次完成。  
Allows for drilling and tapping accomplished at a time.

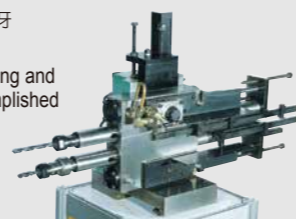

可依工件客製化自動送料系統，如棒材送料機，振動桶，排料架

Customized auto loading system such as bar feeder, vibration barrel, and chute.



型 式 MODEL		SDH-32A/B	SDH-45	SDH-52
彈性夾頭 夾持能力 Maximum chucking capacity	圓形 Bar stock ●	ø32 mm	ø45 mm	ø52 mm
	四角形 Square ■	22 mm	32 mm	37 mm
	六角形 Hexagonal ◆	27 mm	38 mm	45 mm
主軸迴轉速度 (4 速) Spindle speeds (4 speeds)		636/1020/1575/2656 rpm	557/894/1379/2364 rpm	557/894/1379/2364 rpm
刀架滑板 Tool holder slides	主滑板最大行程 Maximum main slide travel	100 mm	100 mm	100 mm
	前副滑板最大行程 Maximum front cross slide travel	100 mm	100 mm	100 mm
	前副滑板傾斜角度 Front cross slide swivels	360°	360°	360°
	後副滑板最大行程 Maximum rear cross slide travel	100 mm	100 mm	100 mm
尾座 Tailstock	尾座軸外徑 Tailstock spindle dia.	ø38 mm	ø38 mm	ø38 mm
	尾座軸內孔斜度 Tailstock spindle taper	MT.3	MT.3	MT.3
	尾座行程 Tailstock spindle travel	150 mm	150 mm	150 mm
床面至中心高度 Height from bed to center		168 mm	168 mm	168 mm
兩中心距離 Distance between centers		270 mm	270 mm	270 mm
馬達 Motor		3 HP	3 HP	3 HP
機械尺寸(長×寬×高) Machine dimensions (L x W x H)		145 x 120 x 165 cm	145 x 120 x 165 cm	145 x 120 x 165 cm
淨重 Net weight		650 kgs	700 kgs	700 kgs

● 本公司產品規格、設計特性均不斷研究改進，規格若有變動，恕不另行通知。

● All specifications, dimensions and design characteristics shown in this catalogue are subject to change without notice.



## 特性 FEATURES

- 頭部 Headstock:**  
 採用油浸式自動循環潤滑系統，能高速運轉及重切削加工。  
 Is oil bath, automatic circulatd lubrication, enable the machine suited for high speed running and heavy cutting.
- 主軸 Spindle:**  
 採用鉻鉬合金鋼(SCM-21),經精密加工，熱處理及研磨，主軸安裝於精密斜角滾珠軸承，可微調預壓，永保精度。  
 Made of chrome molybdenum(SCM-21), precision machined, heat treated and precision ground. Spindle is mounted on precision angular contact ball bearing ensures high accuracy year after year.
- 滑板 Carriage:**  
 精密加工組合，滑行程度準確，全部滑道採鳩尾槽型設計，滑板互換簡便。  
 Precision constructed to guarantee extreme slide accuracy. Dovetailed cross and saddle slide ways.
- 尾座 Tailstock:**  
 尾軸管由中碳鋼(S45C)製成，經熱處理及研磨。尾軸管進給以把手操作。  
 Quill made of mild carbon steel precision machined, heat treated and precision ground. Fast quill feed is operated by hand lever.
- 床身 Bed:**  
 床面寬闊，結構穩固，剛性最佳。  
 Wide surface, ribbed and rugged constructed to give maximum rigidity.
- 腳架 Foot stand:**  
 鑄鐵構造，提供本機最穩定之支撐。  
 Cast iron foot provides rugged support for the machine.
- 離合器及剎車系統精心設計及改良而成，操作順暢，減輕人力疲勞。  
 Well designed and improved clutch brake system gives smooth operation, that minimize operator fatigue.
- 零件加工成本可大大降低。  
 Very low production cost.
- 腳踏式操作控制 Foot pedal operation control:**  
 踩腳踏運動起動，鬆開踏板運轉停止。  
 Treadle on pedal for running operation, release pedal stop spindle.

## 零件加工例 APPLICATION EXAMPLE

適用於大量生產零件之精密車削加工。如鐘錶、相機電子、汽機車、自行車、針車、五金等零件。上圖所示僅為部分典型代表例而已。  
 Well suited for mass production cutting parts of clock, watch, camera, sewing machine, motorcycle, bicycle, automobile, electronics, instrument...etc.



## 標準配件 STANDARD ACCESSORIES

### 手動彈性夾持裝置

- 此裝置提供工件快速又方便之夾緊或卸放，不必停止馬達運轉。適合各類型彈性夾頭。

### 頭部

- 裝置彈性夾持機構。頭部可安裝油壓式三爪夾頭，空壓式三爪夾頭，空油壓迴轉氣缸，普通三爪夾頭，及內夾是彈性夾頭，上部切刀架。

### HAND LEVER COLLET CLOSER

Designed to takes various collets, the collet closer provides faster ch-ucking without stopping the lathe.

### HEADSTOCK

- Built with collet closer for nonstop chucking.
- Available to be mounted with hydraulic power chuck...Pneumatic power chuck...3 jaws scroll chuck ...rotating cylinder... Reverse chucking collets clamping from the inner diameter...Over cutter.

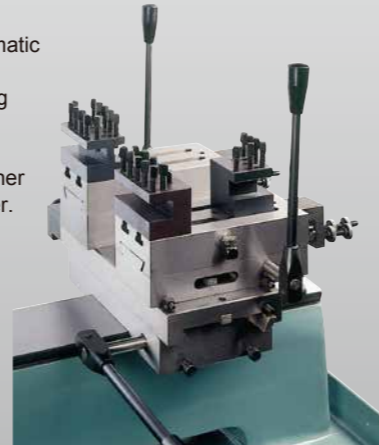

### 雙副滑板(前、後滑板)

- 前副滑板裝有2個刀架。
- 後副滑板裝有1個刀架。
- 前副滑板可做360°傾斜角度調整。刀架互換簡單，並可依加工需要加裝刀架。

### DOUBLE CROSS SLIDE (front and rear)

- Front cross slide equipped with 2 tool holders. Rear cross slide equipped with 1 tool holder.
- Front cross slide may be swivelled 360°.
- Tool holder is easily interchanged for various application.



## 選配件 OPTIONAL ACCESSORIES

### 上部切刀架V1(選配件)

- 此刀架可做工件切斷用，還具車多溝，車外徑功能。
- 上下行程55mm。
- 側向行程45mm。

### OVER CUTTER V1 (Optional Accessories)

- Sliding lateral movement
- In addition to perform cut-off pur-pose, it also available for cutting multiple necks, turning outside diameter.
- Down stroke 55mm.
- Lateral stroke 45mm.



### 自動送料架(選配件)

- 長料可自動進給，節省每次加工入料之麻煩。
- 料管長3000mm。料管直徑隨個機型夾頭夾持能量而定。

### AUTO BAR FEEDER (Optional Accessories)

- Provides automatically feed bar stocks into collet, that eliminates hand loading of workpieces.
- Feeder length 3000mm, Diameter varied with collet chucking capacity of each model.



### 可選配 氣壓迴轉缸，變頻馬達，角牙式滑板

- Pneumatic cylinder , Inverter motor , Lead screw type slide (Optional)



### 上部切刀架V2(選配件)

- 此刀架具工作切斷，車單溝功能。
- 上下行程55mm。

### OVER CUTTER V2 (Optional Accessories)

- Fixed movement
- Perform cut-off, and cutting single neck.
- Down stroke 55mm.



### 彈性夾頭(選配件)

- 照片所示為典型彈頭夾頭。特殊彈性夾頭可另行指定。訂購時請指明尺寸

### COLLETS (Optional Accessories)

- Picture shown are typical collets, special collets are available upon request.



### 氣壓自動夾持裝置(選配件)

- 有腳踏或手動開關控制供選擇。
- 具工件計數功能。

### PNEUMATICALLY AUTOMATIC COLLET CHUCKING DEVICE (Optional Accessories)

- Choice of foot or hand switch control.
- Has parts counting Function.





## SD-15



此機型為昇岱桌上車床中之最小機種

- 彈形夾頭最大夾持能力：
  - 圓形：Ø15mm
  - 四角形：10mm
  - 六角形：12mm
- 最長加工長度：70mm
- 3段主軸速度：1118/1720/2800RPM
- 馬力1HP

**THE SMALLEST MODEL AMONG SENDAY BENCH LATHES**

- MAXIMUM CHUCKING CAPACITY:
  - BAR STOCK : Ø15mm
  - SQUARE :10mm
  - HEXAGONAL :12mm
- Turning length up to 70mm.
- 3 spindle speeds : 1118/1720/2800RPM
- 1HP motor

## SD-25 A/B

- SD-25(普通型)三段主軸速度
- 彈性夾頭最大夾持能力：
  - 圓形：Ø25mm
  - 四角形：18mm
  - 六角形：22mm
- 最長加工長度：80mm
- SD-25(普通型)主軸速度3段：1050/1720/2800RPM
- 馬力2HP

- SD-25(BASIC TYPE)3 SPINDLE SPEEDS
- MAXIMUM CHUCKING CAPACITY:
  - BAR STOCK : Ø25mm
  - SQUARE :18mm
  - HEXAGONAL :22mm
- Turning length up to 80mm.
- D-25(BASIC TYPE) 3 spindle speeds : 1050/1720/2800RPM
- 2HP motor



## SD-25 PA/PB



- SD-25(強力型)六段主軸速度
- 彈性夾頭最大夾持能力：
  - 圓形：Ø25mm
  - 四角形：18mm
  - 六角形：22mm
- 最長加工長度：80mm
- SD-25(強力型)主軸速度6段：775/1260/2050/1443/2345/3910RPM
- 馬力2HP

- SD-25(POWERFUL TYPE) 6 SPINDLE SPEEDS
- MAXIMUM CHUCKING CAPACITY:
  - BAR STOCK : Ø25mm
  - SQUARE :18mm
  - HEXAGONAL :22mm
- Turning length up to 80mm.
- D-25(BASIC TYPE) 3 spindle speeds : 775/1260/2050/1443/2345/3910RPM
- 2HP motor

## SD-32 A/B



- 彈形夾頭最大夾持能力：
  - 圓形：Ø35mm
  - 四角形：22mm
  - 六角形：27mm
- 最長加工長度：100mm
- 4段主軸速度：636/1020/1575/2656RPM
- 馬力2HP

- MAXIMUM CHUCKING CAPACITY:
  - BAR STOCK : Ø35mm
  - SQUARE 22mm
  - HEXAGONAL : 27mm
- Turning length up to 100mm.
- 4 spindle speeds : 636/1020/1575/2656RPM
- 2HP motor

## SD-45

- 彈形夾頭最大夾持能力：
  - 圓形：Ø45mm
  - 四角形：32mm
  - 六角形：38mm
- 最長加工長度：100mm
- 4段主軸速度：557/894/1379/2364RPM
- 馬力2HP

- MAXIMUM CHUCKING CAPACITY:
  - BAR STOCK: Ø32mm
  - SQUARE : 32mm
  - HEXAGONAL : 38mm
- Turning length up to 100mm.
- 4 spindle speeds : 557/894/1379/2364RPM
- 2HP motor



## SD-52



此機型為昇岱桌上車床中之最大機種

- 彈形夾頭最大夾持能力：
  - 圓形：Ø52mm
  - 四角形：37mm
  - 六角形：45mm
- 最長加工長度：100mm
- 4段主軸速度：557/894/1379/2364 RPM
- 馬力2HP

**THE BIGGEST MODEL AMONG SENDAY BENCH LATHES**

- MAXIMUM CHUCKING CAPACITY:
  - BAR STOCK : Ø52mm
  - SQUARE : 37mm
  - HEXAGONAL : 45mm
- Turning length up to 100mm.
- 4 spindle speeds : 557/894/1379/2364 RPM
- 2HP motor

## SD-32D

角牙式

- 適用於小量生產，尺寸多樣化之零件加工。
- 頭部安裝5°三爪夾頭。
- 滑板進給以螺桿驅動。
- 橫向行程110mm，複刀座行程100mm。
- 4段工軸速度，557/894/1379/2364 RPM。
- 馬力2HP

LEAD SCREW TYPE SLIDER

- The version model is well suited for small lot production, with various sizes.
- Headstock mounted with 3 jaws scroll chuck, in sleed of collet chuck. Chuck size 5".
- Slides driven by feed screw.
- Cross travel 110mm, lateral slide 100mm.
- 4 spindle speeds : 557/894/1379/2364 RPM.
- 2HP motor.

