

ROYAL 羅翌科技

工具機精密主軸

High Precision Spindles Solutions

精密研發 創新工藝



高精度

高穩定

高剛性

高效率

High precision, stability, rigidity and efficiency

皮帶式主軸

- ▶ 錐孔完整，精度及剛性高
- ▶ 維修容易，簡易保養



型號	外徑 (mm)	最高轉速 (rpm)	錐孔規格	拉刀力 (kgf)	軸承內徑 (mm)	軸承潤滑方式	冷卻方式	重量 (kg)	中心出水
RB3002	Ø100	15000	BT30/BBT30	300±50	Ø50	油脂	油冷	約17	選配
RB3021	Ø120	15000	BT30/BBT30	300±50	Ø60			約20	
RB4006		12000	BT40/BBT40	700±50	Ø60			約33	
RB4388	Ø150	12000	BT40/BBT40	1000±100	Ø70			約56	
RBH004			HSK A63	1800~2300	Ø70			約56	
RB4078	Ø155	12000	BT40/BBT40	1000±100	Ø70			約60	
RBH018			HSK A63	1800~2300	Ø70			約60	
RB5233			8000	BT50/BBT50	1500±100			Ø80	
RB5004	Ø190	10000	BT50/BBT50	1800±100	Ø100			約123	
RB5242	Ø200	10000	BT50/BBT50	1800±100	Ø100			約130	

RB3002

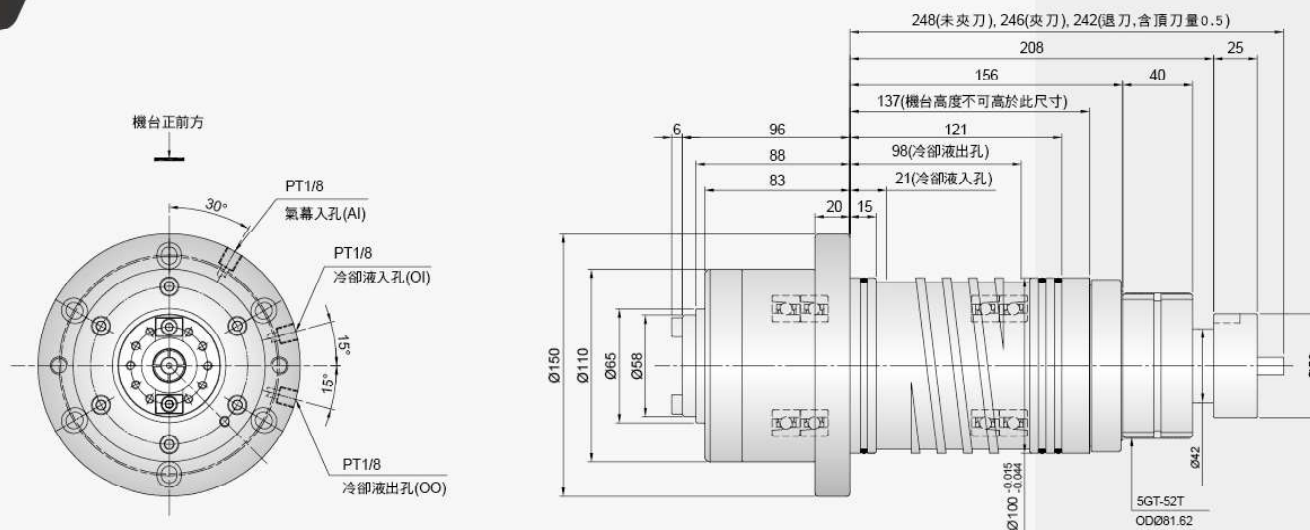

RB4006

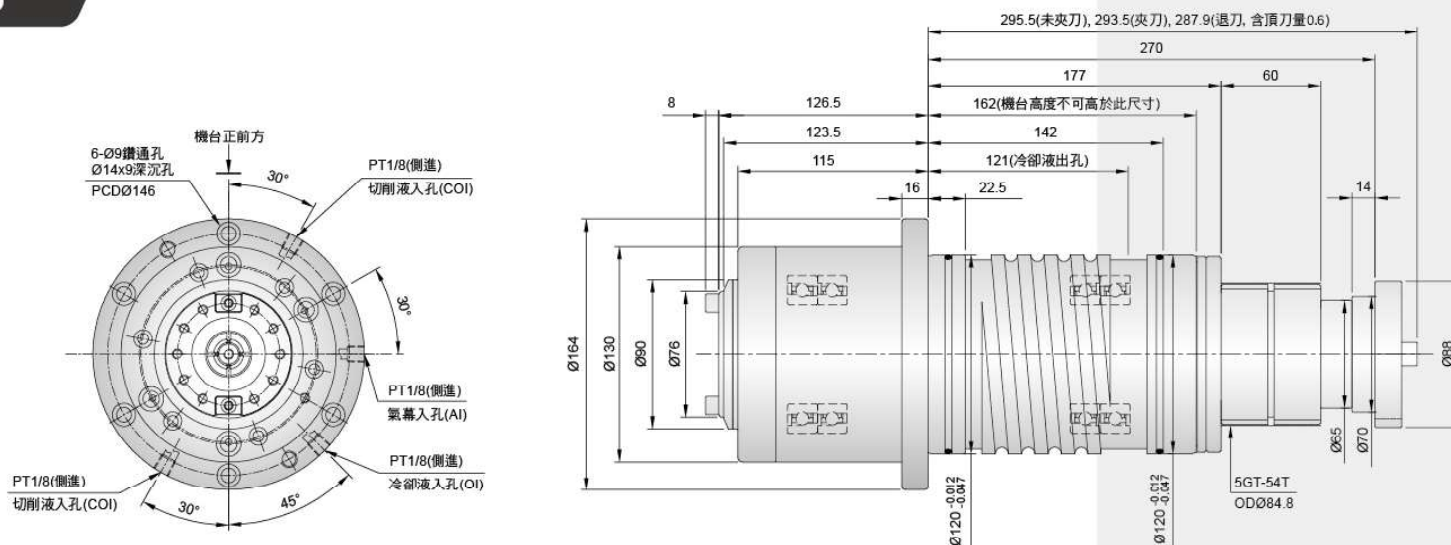

RB4388

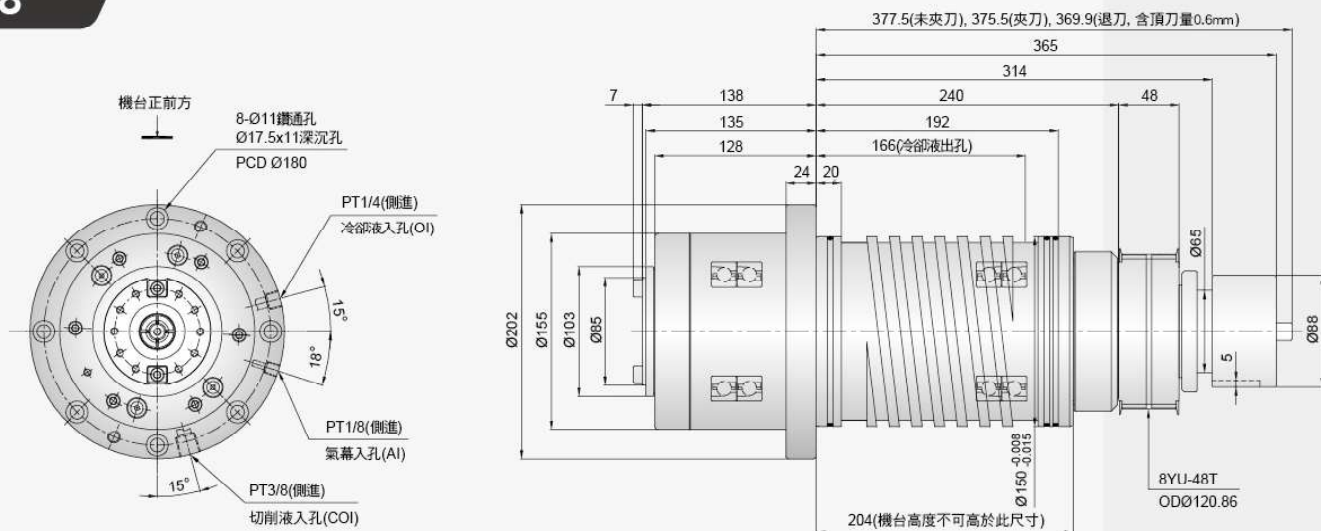

RB4078

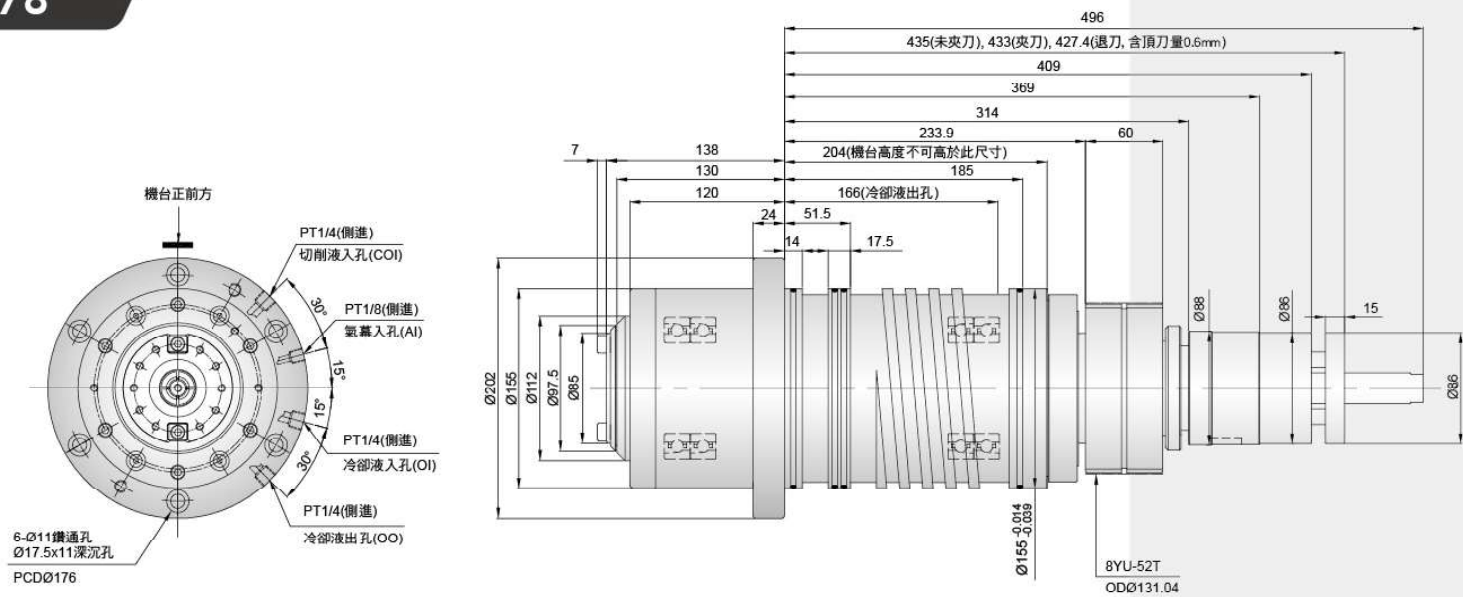

RB5233

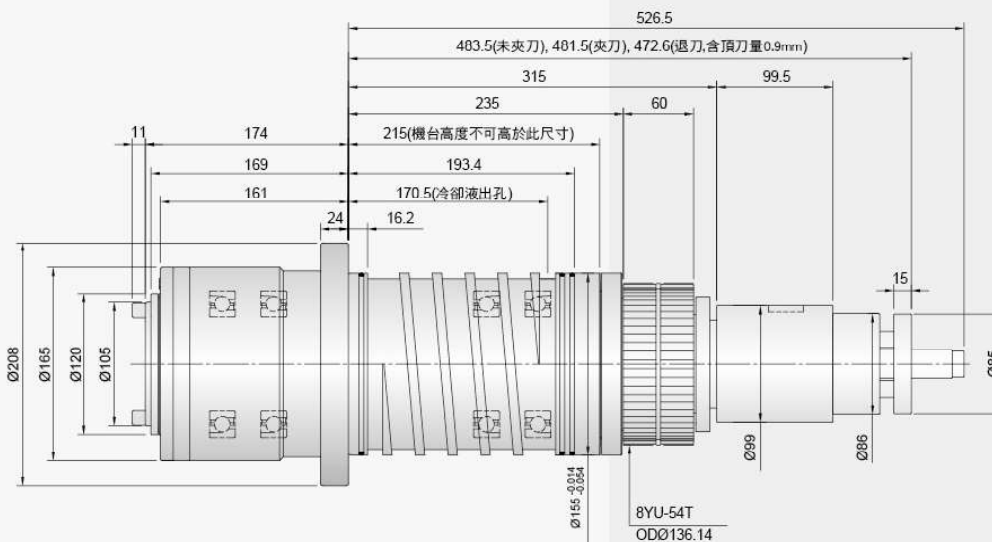
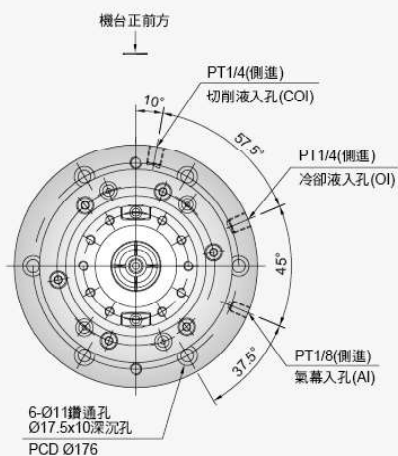

RB5004

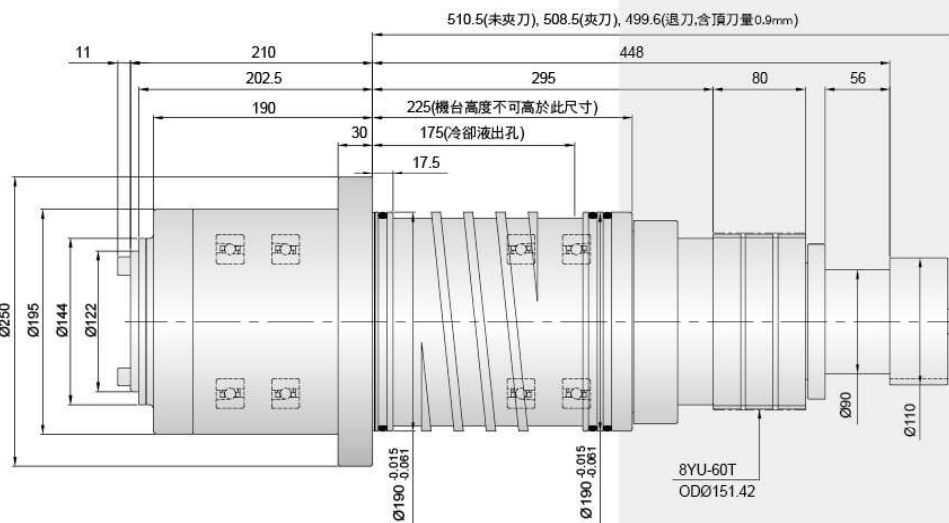
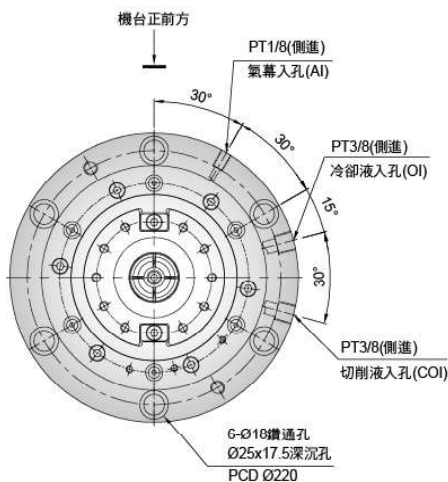

Your Spindle Solutions
Speed, Precision, Rigidity

ROYAL 羅翌科技股份有限公司
Royal Precision Tools Corporation

營運總部

414 臺中市烏日區中山路一段21號

電話：+886 4 2338 2068

傳真：+886 4 2338 2161

E-mail：royal_sa@royal-spindles.com.tw

集集廠

552 南投縣集集鎮中集路66號

電話：+886 4 2338 2068

傳真：+886 49 276 2812



www.royal-spindles.com